



FACULTY
OF MATHEMATICS
AND PHYSICS
Charles University



Calorimetry in Prague (Charles University, Czech Academy of Sciences, Czech Technical University)

- Beginnings – experiment NA4 – BCDMS collaboration
- LAr calorimeter, Spacal – experiment H1
- Tilecal calorimeter – experiment ATLAS
- Calorimeter prototypes HCAL, ECAL – CALICE collaboration
- Conclusions

NA4 (Bologna-CERN-Dubna-Munich-Saclay)

An experiment to extend the inclusive μN DIS to the highest E and Q^2 at SPS, spokesperson C. Rubia

- Detector principles: Produced particles interact in the steel of the magnet, energy of the cascade is determined by sampling the losses with $1 \times 1 \text{ m}^2$ scintillators located at every 10 cm within steel (**calorimeter**)

- 8 physicists from Prague participated

Data taking: 1979 – 1985, analysis up to 1991

- Our contribution: data analysis & map of the toroidal magnetic field, Fermi motion corrections to DIS, on-line monitoring

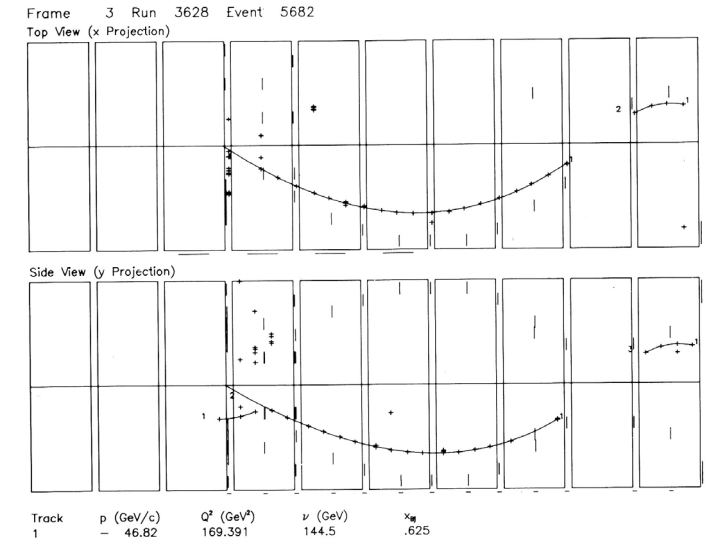

HERA



$\sqrt{s} = 320 \text{ GeV}$

Start of construction 1984

Data taking: start May 1992 end June 2007

ca. 800 physicists at 2 e-p experiments

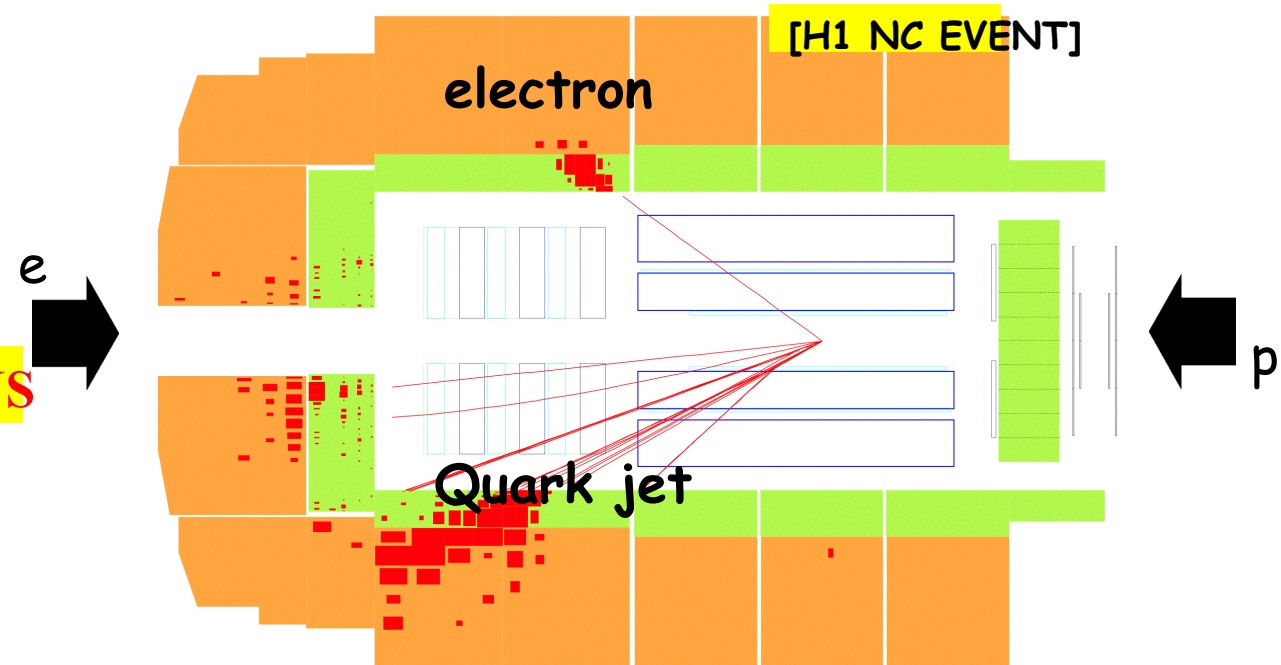

Electrons scatter from Quarks at HERA

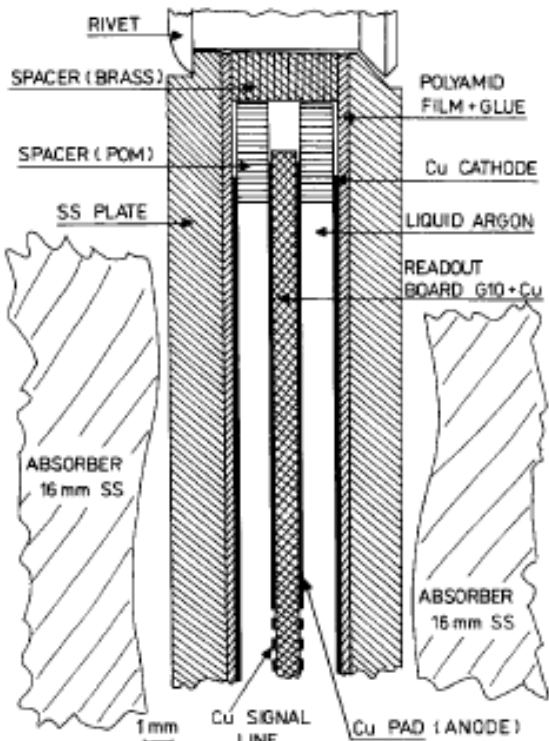
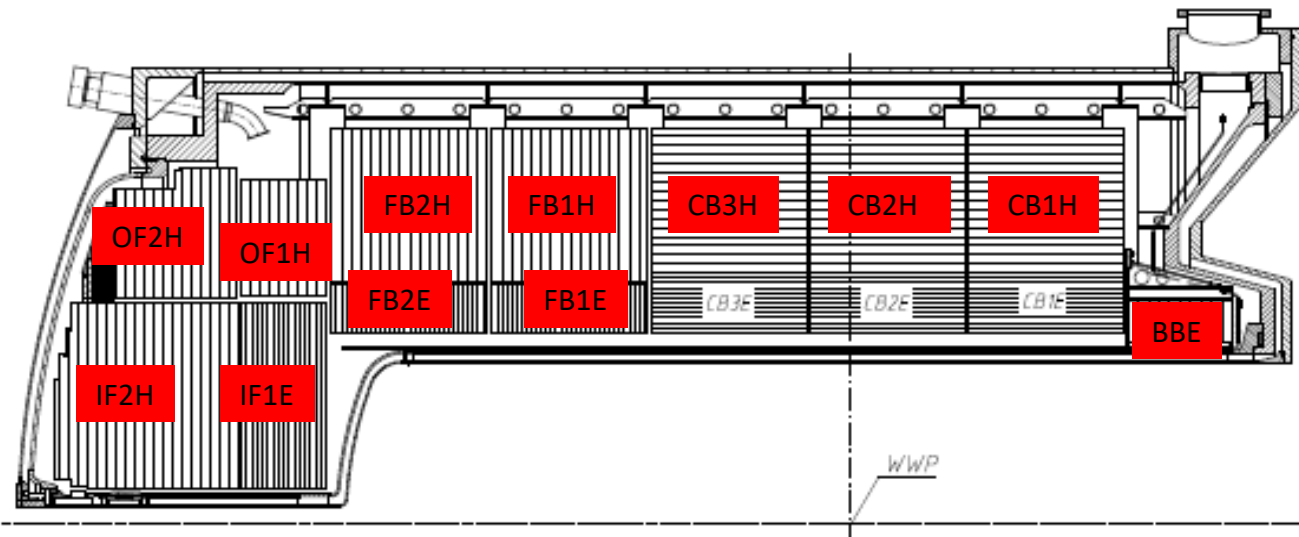

Fig. 1. Hadron calorimeter cell.

Production of read-out boards for the LAr calo

- Copper plated (G10) boards covered with photoresist
- Mechanical engraving on both sides (CAS, CU Prague)
- Exposure – masks from Prague (IOP Košice, Slovakia)
- Etching, hole drilling, quality control
- **Red segments** of hadron/electromagnetic calo produced at Czechoslovak Institutes/industry



In summary for LAr

Total number of electrodes	~ 9000
Prague institutes CAS & CU	~ 1800
Košice institute IEP SAS	~ 1800
industry – TESLA Přelouč	~ 5400
HV electrodes Prague	~ 6400
Electrode size	Up to 850x1000 cm ²
Electrode total area	~ 4000 m ²
Financial contribution to H1	~ 3.5 M DM (~3.5 %)



Hadron barrel calorimeter assembly at LAL Orsay

CALICE, Praha, 27.09.2023

Manufacture of readout boards for a liquid argon calorimeter

J. Antoř, J. Bán, J. Ferencei, P. Muriň, J. Špalek and P. Štefan
Institute of Experimental Physics SAV, CS-04353 Kollce, Czechoslovakia

J. Cvach, I. Herynek, J. Hladký, V. Kohl, V. Šimák, P. Staroba, J. Strachota and P. Závada
Institute of Physics ČSAV, CS-18040 Praha 8, Czechoslovakia

Š. Valkár, A. Valkárová and J. Žáček
Nuclear Centre, Charles University, CS-18000 Praha 8, Czechoslovakia

Received 31 August 1990 and in revised form 2 January 1991

We describe techniques used for the production of large (1 m²) printed circuit boards which are the readout electrodes of the H1 calorimeter at the HERA collider. In particular, we have developed a direct method of generating the copper image on G10 sheets to meet the multitude of board types with a very low repetition rate.

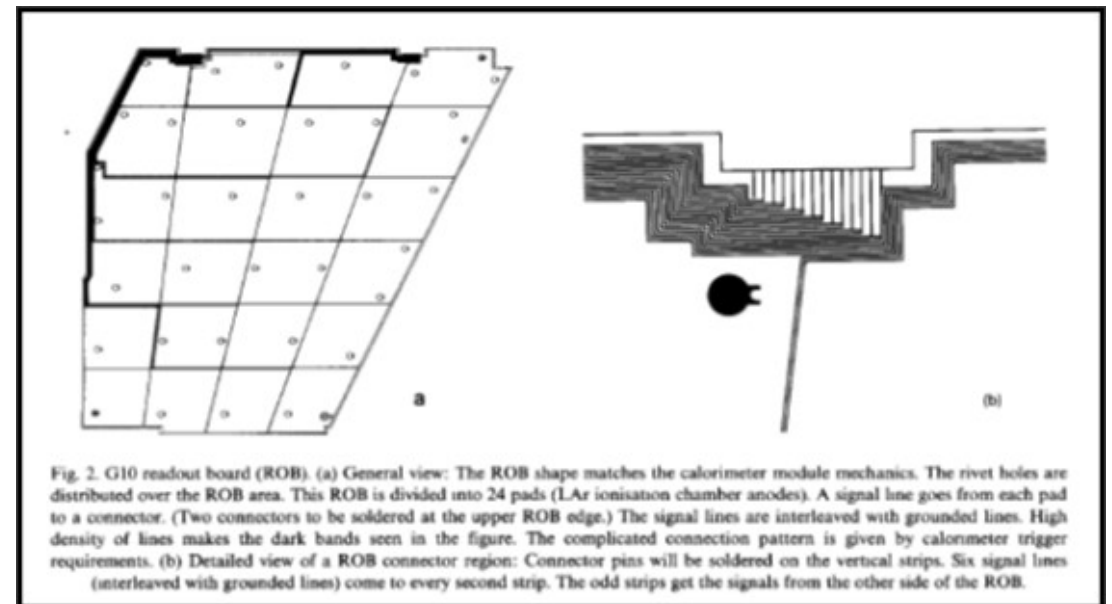
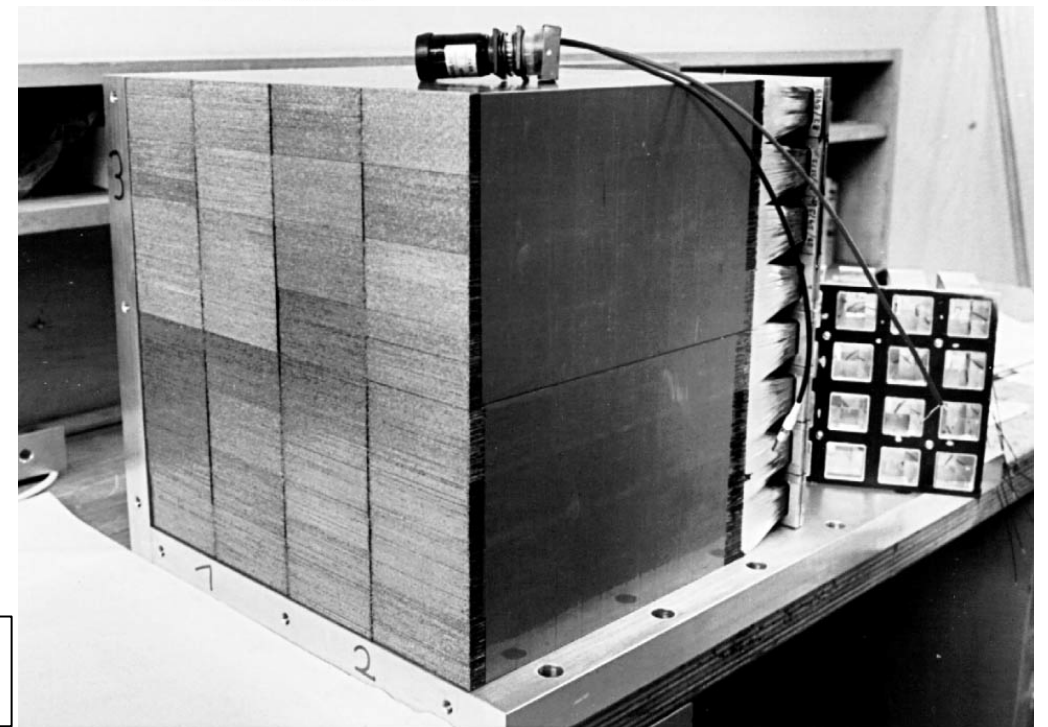
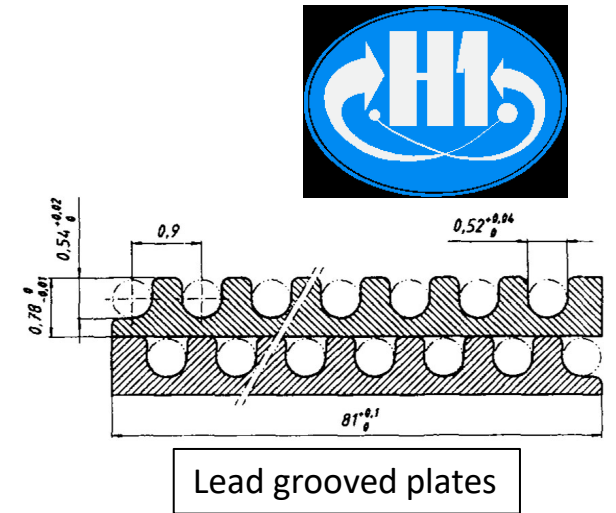
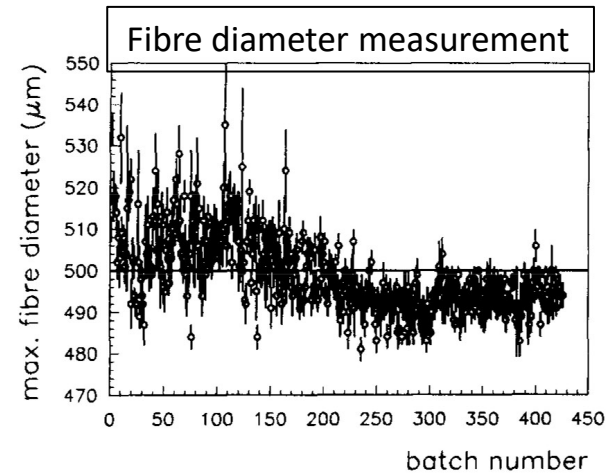

Fig. 2. G10 readout board (ROB). (a) General view: The ROB shape matches the calorimeter module mechanics. The rivet holes are distributed over the ROB area. This ROB is divided into 24 pads (LAr ionisation chamber anodes). A signal line goes from each pad to a connector. (Two connectors to be soldered at the upper ROB edge.) The signal lines are interleaved with grounded lines. High density of lines makes the dark bands seen in the figure. The complicated connection pattern is given by calorimeter trigger requirements. (b) Detailed view of a ROB connector region: Connector pins will be soldered on the vertical strips. Six signal lines (interleaved with grounded lines) come to every second strip. The odd strips get the signals from the other side of the ROB.

Improvement of scattered e^- measurement – lead/scintillating fibre calorimeter Spacal

- Two calorimeter wheels - elmg & hadronic built in 1993-5, \varnothing 1.6 m
- Acceptance $153^\circ < \theta < 177.5^\circ$
- $\sigma/E = 7\%/VE \oplus 1\%$
- Elmg: 0.5 mm scintillating fibres in 0.8 mm lead grooved plates
- Participation in fibre (Bicron BF-12) production monitoring: fibre diameter & attenuation length
- Calorimeter module construction – no dead space
- Trigger electronics
- Spacal monitoring



ATLAS hadron calorimeter Tilecal since 1992

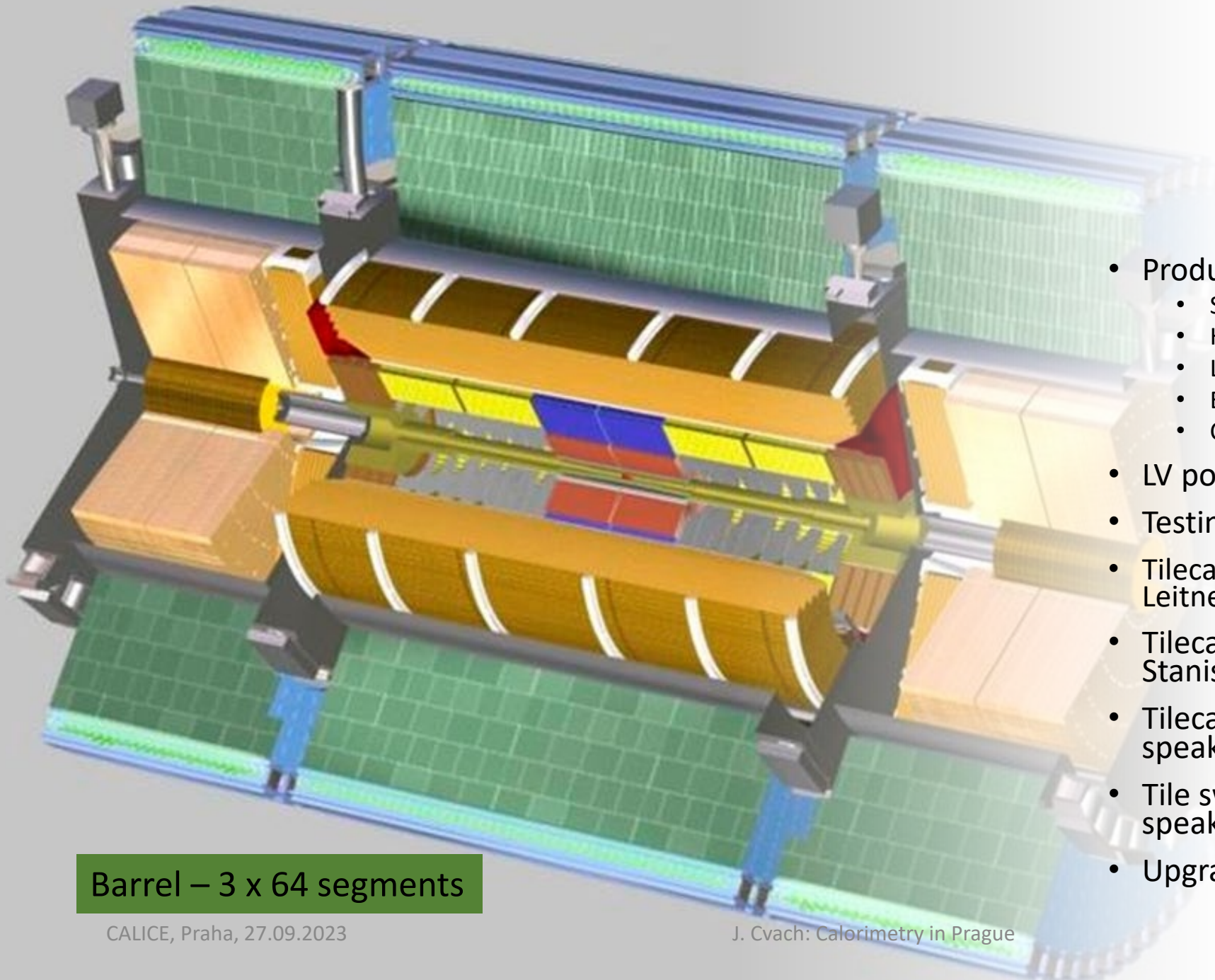

- Production
 - Submodules
 - HVS1 power supplies
 - LV power supplies
 - Electronics
 - Cables
- LV power supplies design – Ivan Hruška
- Testing, Monitoring
- Tilecal project leader 2001-2005 – Rupert Leitner
- Tilecal Maintenance and Infrast. – Stanislav Němeček
- Tilecal Data Prep. and Perform. & Chair of speakers committee – Tomáš Davídek
- Tile sw and data integrity & Chair of speakers committee – Jana Faltová
- Upgrade

Barrel – 3 x 64 segments

Early stage 1992 – middle of 2000s, R&D and construction

Mechanical parts

- R&D – methods of module construction (glueing, painting)
- 1/4 of the long barrel iron structure built in Prague: 309 submodules (1 t)
- steel sheet pieces for the whole collaboration
- 10 400 light mixers for all PMs
- Prototype testing at beam tests (+ muon wall)

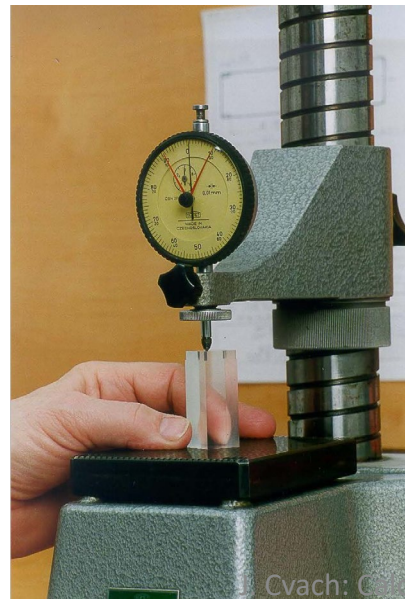

HV supplies for PMs

- Two output levels -830 V, -950 V at 0.25% accuracy, long term stability 0.01%
- Each channel set remotely, over/undercurrent protection ...
- Design made by I. Hruška, 16x HVS1 chassis, 128 x 2ch HV cards (for ~ 10 000 PMs) produced at TESLA Hloubětín Praha (and installed in 2005)

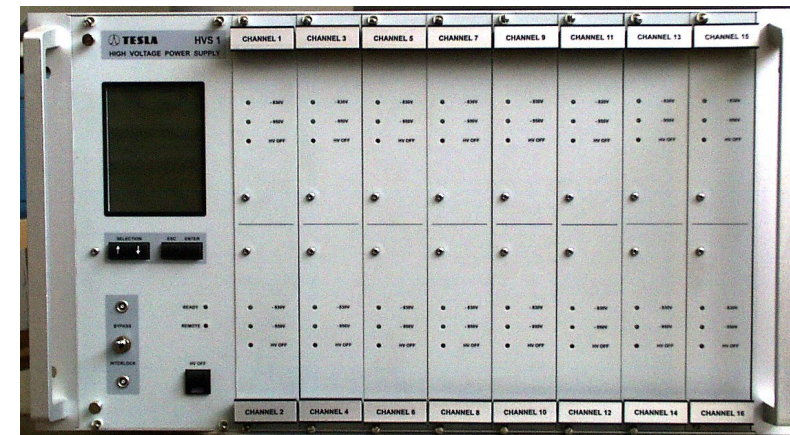

Tilecal Low Voltage PS

Radiation-tolerant, custom made, dual stage system

- Dual stage power supply system
 - First stage - 3 x230VAC -> 3x200VDC/8.5A
 - Second stage 200VDC -> 3.3V, $\pm 5V$, $\pm 15V$ as unified brick with only small changes for different voltages
- Rad-tol & Mag-tol part is second stage
 - Custom designed DC/DC converter - brick
- Remote control & monitoring



Tilecal barrels

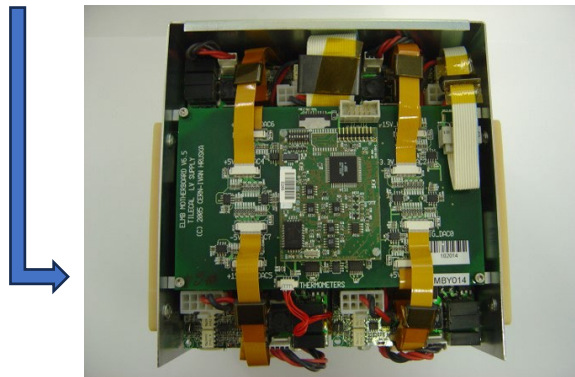
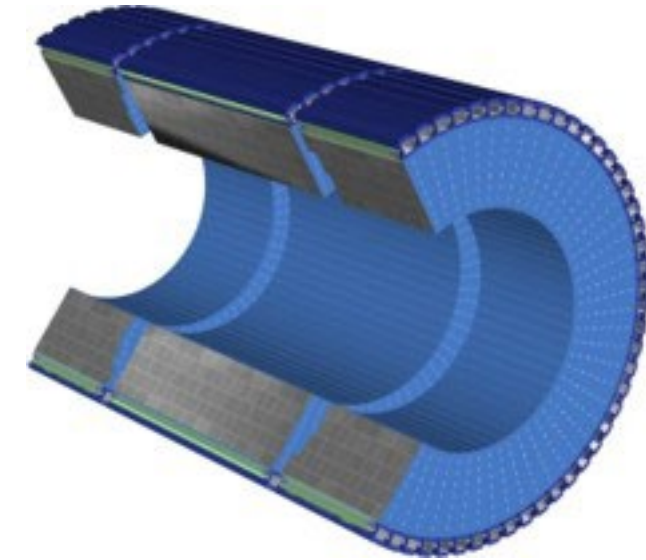

CALICE, Praha, 27.09.2023



J. Cvach: Calorimetry in Prague

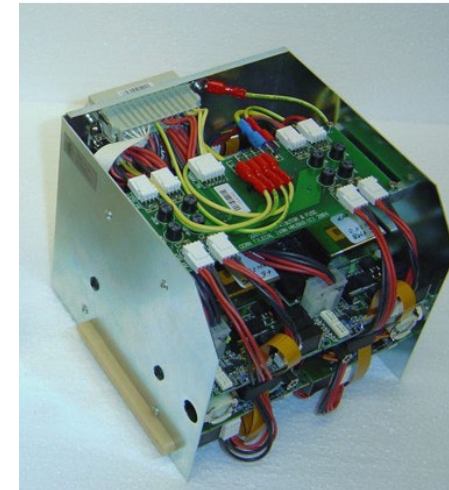

LV PS box

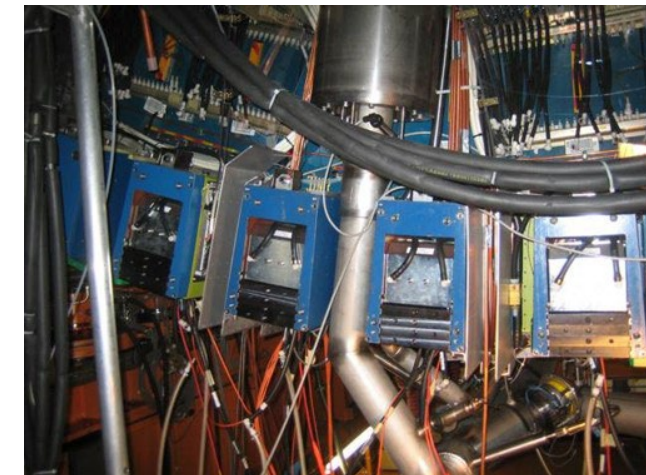

LV boxes in tilecal

Tilecal at the LHC data taking

- HV PS for ~ 10 000 PMs produced in TESLA Hloubětín Praha – stable performance
- 200 V DC PS replaced by new TDK-Lambda GEN300-8-1P200 PSs (better monitoring, powerful cooling, more compact), new racks
- DC – DC converters (bricks) replaced by new production from ANL (2080 pieces in 2012) installation with Prague presence (Ivo, Jiří)
- Tilecal operation and maintenance - coordinator Stanislav Němeček (2015 ATLAS Award for Tilecal maintenance)
- Work on the DQ-related software
 - consolidation of current DQ tools and development of new tests
 - brand new DQ history tool (<https://tio.cern.ch/dq-history/>)
 - documentation update
- Tilecal Data Prep. & Perform. – T. Davídek
- Chair of tilecal speaker committee – J. Faltová

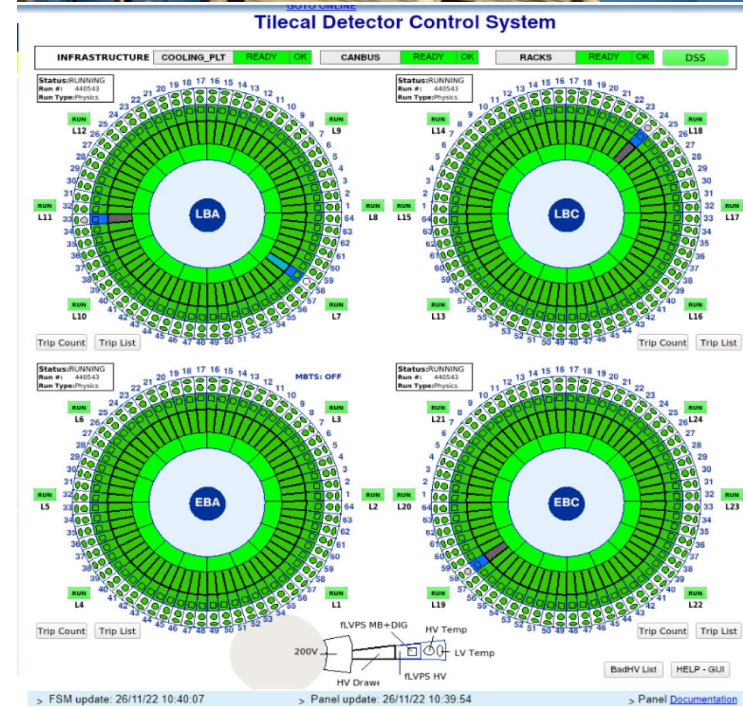

Module	Test name	DQM status
EBA11	CRC_global	Red ← R G G G G
	DMUErr_HG	Red ⚠ ← R G G G G
	DMUErr_LG	Red ⚠ ← R G G G G
EBA12	CRC	Yellow ⚠ ← Y G Y Y G
	Gain_Compatibility	Yellow ⚠ ← Y Y G G G
EBA19	PedestalRMS_HG_LowFreq	Yellow ⚠ ← Y G Y Y Y
EBA37	Gain_Compatibility	Yellow ⚠10 ← G Y Y Y Y
EBA44	Gain_Compatibility	Orange ✓ ⚠

Developments & upgrade for HL-LHC

- TileCal upgrade consists in completely new electronics and readout (FE electronics re-design, 4 independent mini-drawers per module, remote HV for PMTs, ...)
- CZ institutes are responsible for assembly and QA tests of half of low-voltage power supplies (LVPS)
 - participation in development of LVPS
 - all metallic boxes and heatsinks will be produced in CZ (DUO Opočno)
 - dummy loads needed for QA tests already produced in Prague
 - half of all LVPS to be tested by FZU
- involvement in module tests in SPS beams @ CERN
 - mostly tests of new electronics and readout, including pulse shape validation and energy reconstruction
 - special program (e.g. low-energy hadron beam) to enrich physics studies
- Upgrade sw and performance studies coordinator (T. Davidek)
- Calibration coordinator (J. Faltová)

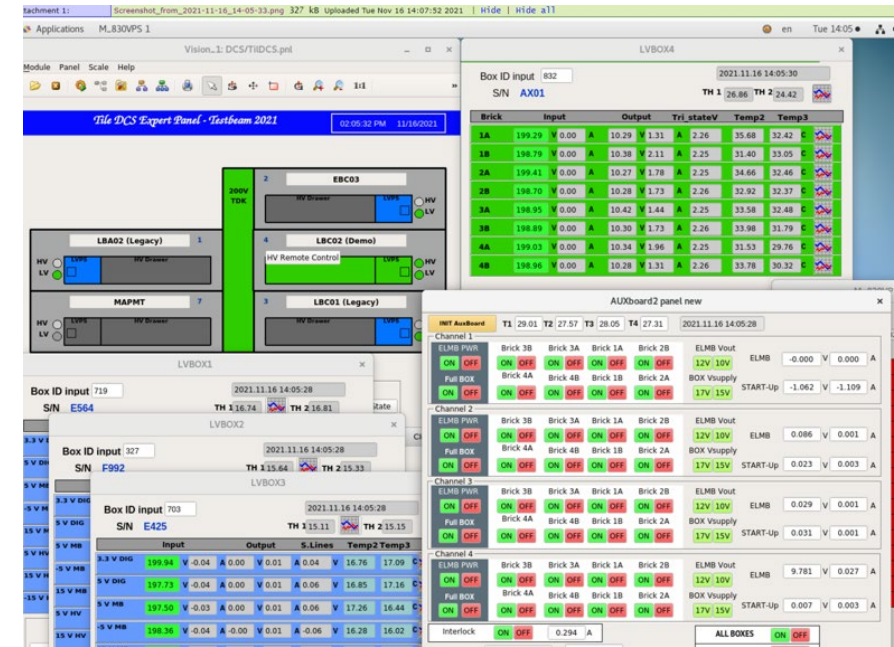
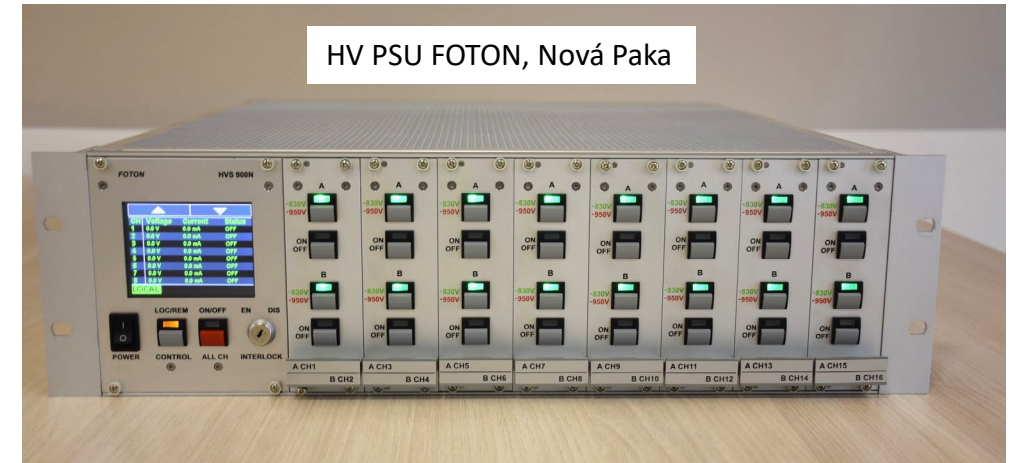

CALICE

- Prague is a member from the beginning (2000?)
- Participation in AHCAL, coordination V. Korbel
- Different preparatory studies: fibers, tiles, APD, electronics
- From 2004, AHCAL coordination by Felix, APD → SiPM
- *Calibration and monitoring system for the AHCAL physics prototype (Ivo, Milan Janata)*
- *ECAL construction coordinated with Ecole Polytechnique (V. Vrba)*
- We organized 2 meetings in Prague:
 - 2002 ECFA/DESY workshop (~ 200 participants)
 - 2007 CALICE collaboration meeting (~ 70 participants)
- Gain stabilization of SiPMs with an Adaptive Power Supply, with University of Bergen, G. Eigen et al., JINST 14 (2019) P05006
- *Light distribution system for SiPMs with ,notched' fibers (J. Smolík, J. Zuklín)*
- Now, European grant AIDAinnova (Ivo, Jiří)

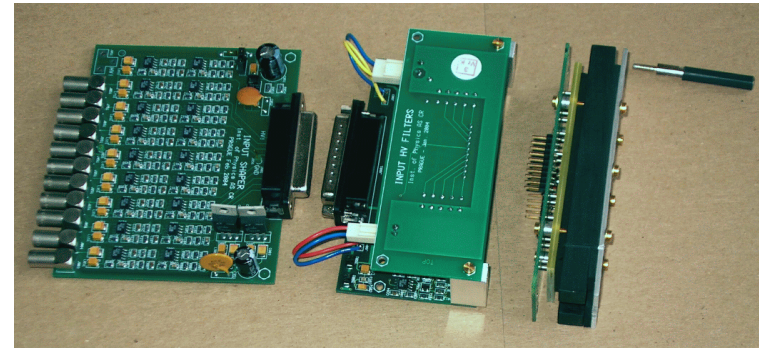

- DAQ for AHCAL (Jiří Kvasnička) from 2014
 - Firmware for many DAQ components: DIF, CCC, LDA
 - Integration effort: (BIF – beam interface), combined and synchronized data taking other with detectors
 - Software (Labview, EUDAQ, DQM, monitoring)

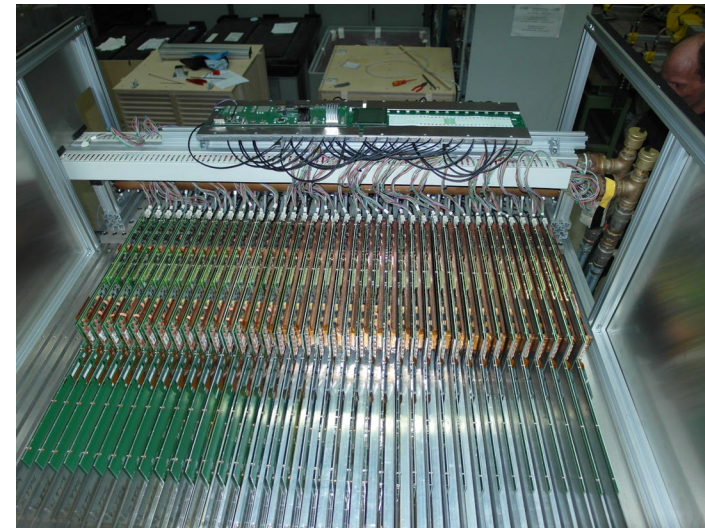

AHCAL in beam tests

AHCAL

- Calibration and monitoring system for the HCAL physical prototype:
 - Gain measurement (single-pixel spectra)
 - SiPM temperature-dependence correction
 - SiPM saturation curve monitoring
- Calibration & Monitoring Board: 12 LEDs, 12 PIN diodes, 228 clear fibres (Ivo)
 - Designed, tested and operated in test beam runs of the prototype
 - the requirements met (original LED driver further developed into Quasi-Resonant driver QMB)
- Development of the optical system with 'notched' fibres (J. Smolík, M. Kovalčuk, J. Zuklín)
 - One LED → three clear fibre with notches → 72 tiles
 - Fibre is damaged in a controlled way such that each notch radiates light of the same intensity
 - Soldering iron with specially formed tip connected to the CNC machine
 - The production process is controlled by continuous measurement of light by PIN diode from notch by dipping the tip into fibre
 - Achieved homogeneity of light spread per fibre ~ 5%

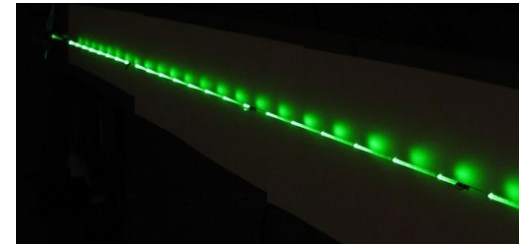
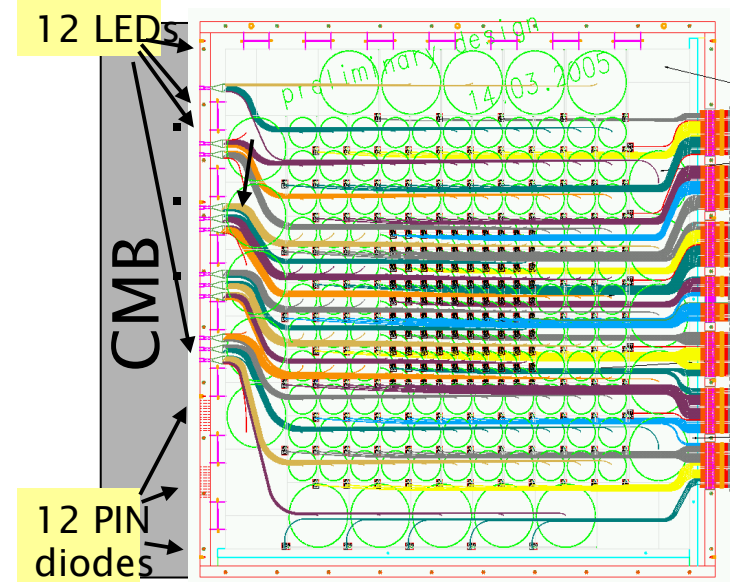
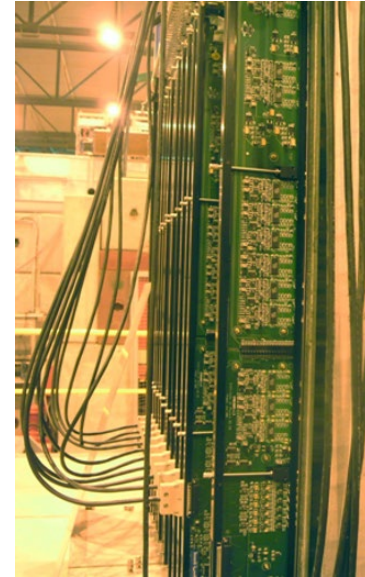

Light output from 24 notches (a.u.), fibres 1-6

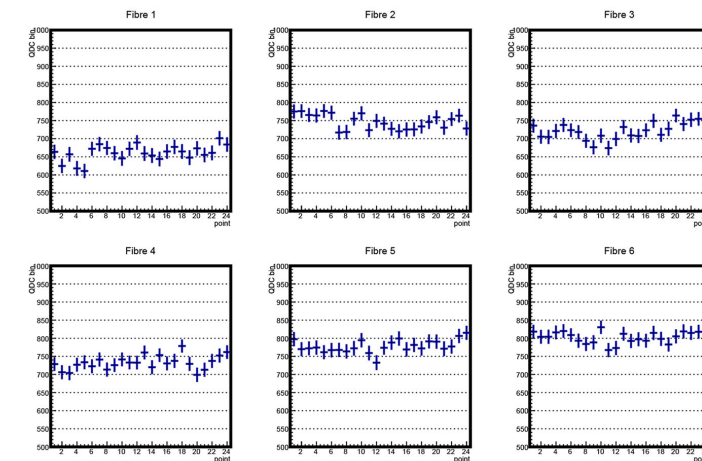

Prague silicon group participation in CALICE



- Development of SiW ECAL sensors and analysis of ECAL performance
- “Old” CALICE ECAL had two sensor manufacturers: ELMA(Ru) and ON Semiconductor (CZ)
- ON Semiconductor in cooperation with FZU produced O(1000) wafers
 - 4” high-resistivity ($12 \text{ k}\Omega\cdot\text{cm}$) N-type wafers $525 \pm 16 \mu\text{m}$ thick
 - 36 detection pads, 1 cm^2 area
- Developed contacting technique using conductive glue
- Active in performance analysis of CERN and DESY testbeam data

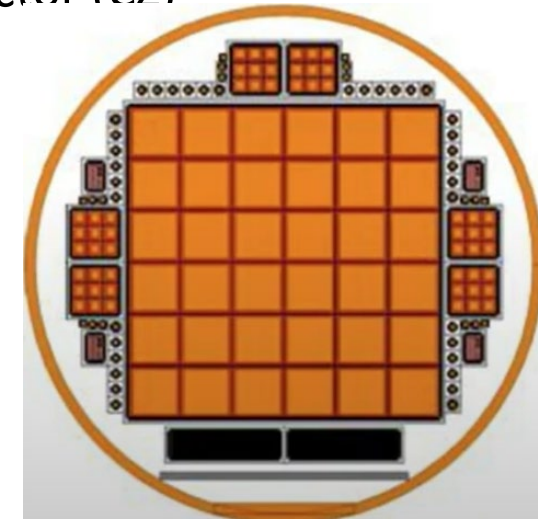

Wafer layout

From Michal Marčíšovský

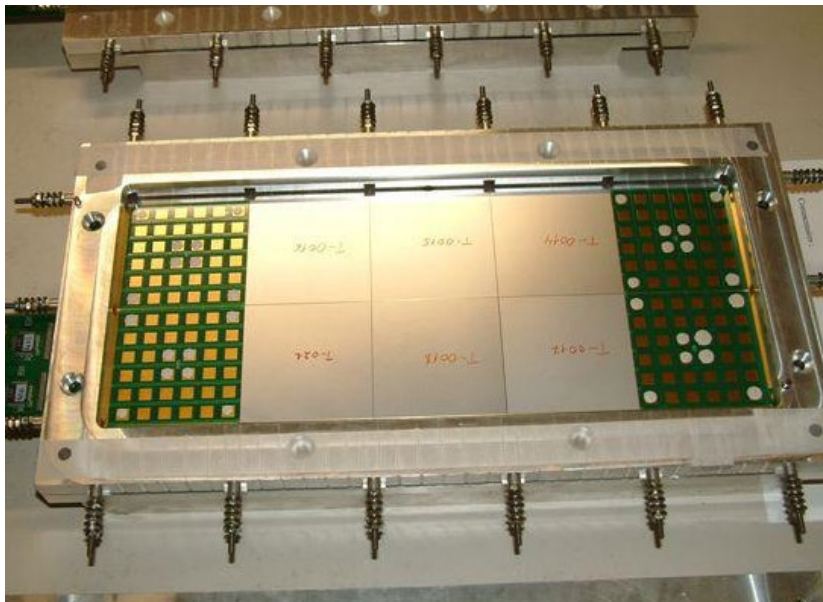

Detector slab during manufacturing



Applying conductive glue

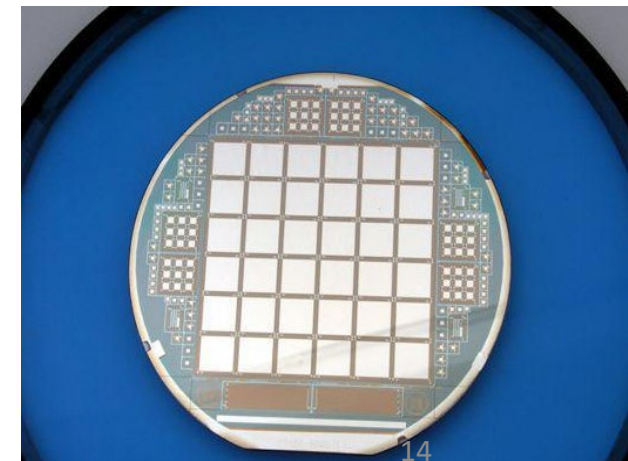

Manufactured sensors

Conclusions

- I tried to show that over ~ 40 years, calorimetry took an important role in projects we participated in/from Prague
- We contributed to experiments H1, ATLAS and RD at CALICE
- This endeavour continues mainly in ATLAS tilecal, AIDAinnova, CALICE and CERN e^+e^- circular collider project
- The laboratory built at FZU & CU for testing the light and Si detectors are now used for future projects DUNE and ATLAS upgrade
- The laboratory for testing & development of Si detectors at CTU (Center for Applied Physics and Advanced Detectors) V. Vrba, M. Marčišovský is oriented on projects at space missions, space weather monitoring and radiation demanding environment

Let me finally to pay tribute to two physicists who passed away in this year and made a significant impact for projects I mentioned here



- **Igor Alekseevich Savin (1930-2023)** head of the Dubna group in the NA4 experiment. In his group eight Prague physicists participated in the experiment on the CERN side. I.A. Savin was then for many years the Director of the High Energy Laboratory, JINR and participated in experiments HERMES, SPIN and COMPASS



- **Miloš Lokajíček (1952-2023)** was for many years the leading person for the Tilecal construction, power supplies development and founded the computer centre for experiments at CERN and Fermilab at FZU. He was also a head of the Department of Data Processing and Detector Development at FZU



Backup

Tilecal during the R&D and construction stage

Tiles assembly at FZU



- submodules for 1/8 of Tilecal
- 3000 t of low carbon steel (Válcovny Dvůr Králové)

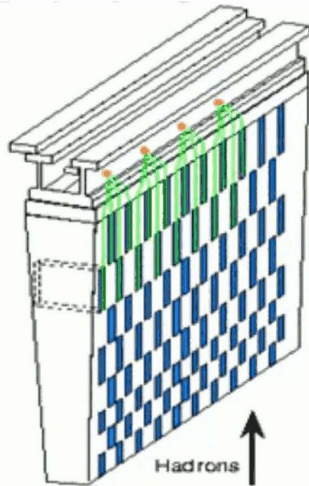

Light mixers at CU



- production of 10 000 light mixers



LV and HV Power Supplies



- delivered by Tesla Hloubětín



R. Leitner - ATLAS Tilecal project manager 2001-2005

Time calibration monitoring in Tile Calorimeter

- Time calibration is set in-situ using jet collision data and is monitored with laser events shot during LHC empty orbits
- The developed tool enabled discovery of several problems - timing jumps, unstable timing, bunch-crossing offset
- SW machinery detects anomalies and allows for time calibration correction on the per-lumi-block basis
- Significant improvement of time measurement in Run-1 (frequent timing jumps), further fine-tuned in Run-2 and Run-3

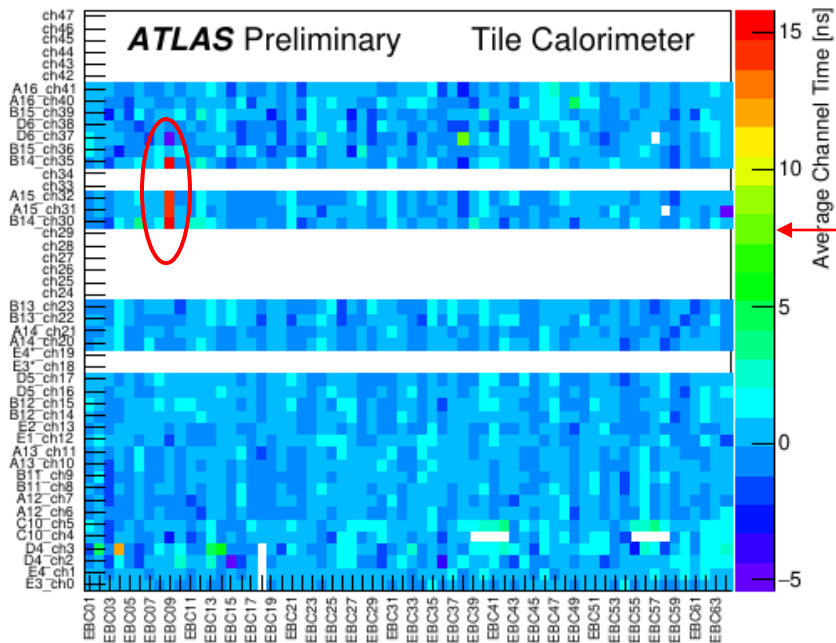
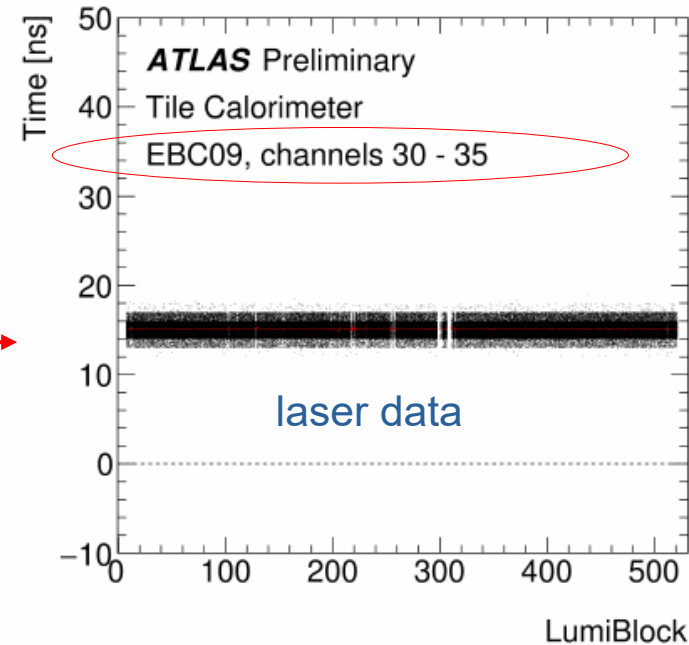

physics data
before and after
the timing jump
correction

