

# Supports and Movers for ATF2 Magnets

R. Sugahara  
KEK

France and Japan Collaboration Meeting  
Feb. 3 - 5, 2006

## New magnets

Dipoles 3

--> Produced this fiscal year (SLAC group)

Beam line Quadrupoles 27

24 magnets were produced last fiscal year, and  
3+1(spare) are produced this fiscal year

FF Quadrupoles 2

--> Reuse FFTB magnets (QC3 type)

Sextupoles 5

--> Produced this fiscal year (SLAC group)

Octupoles ?

Steering magnets ?

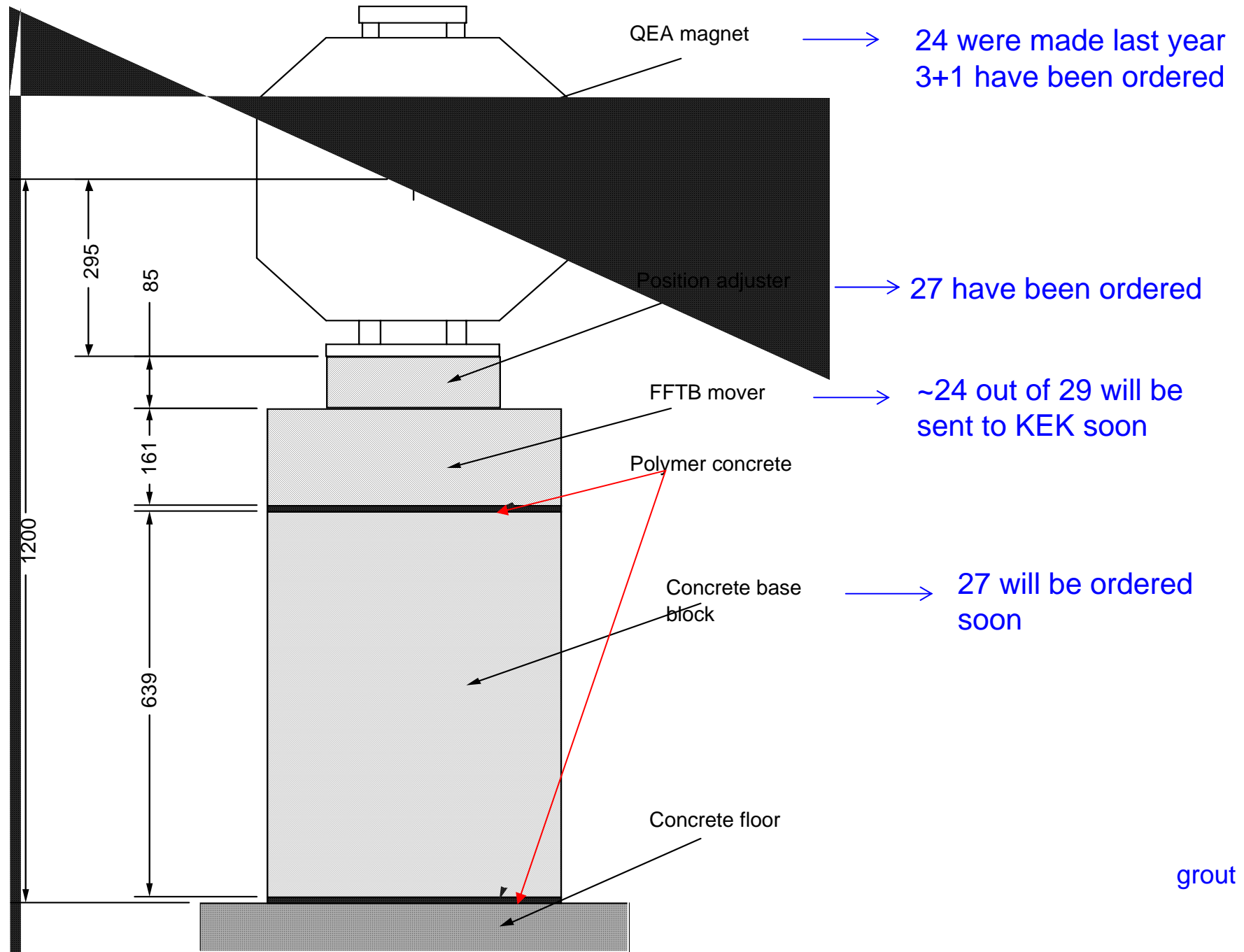

# Sextupole Location

T.Okugi

all the c-band BPMs

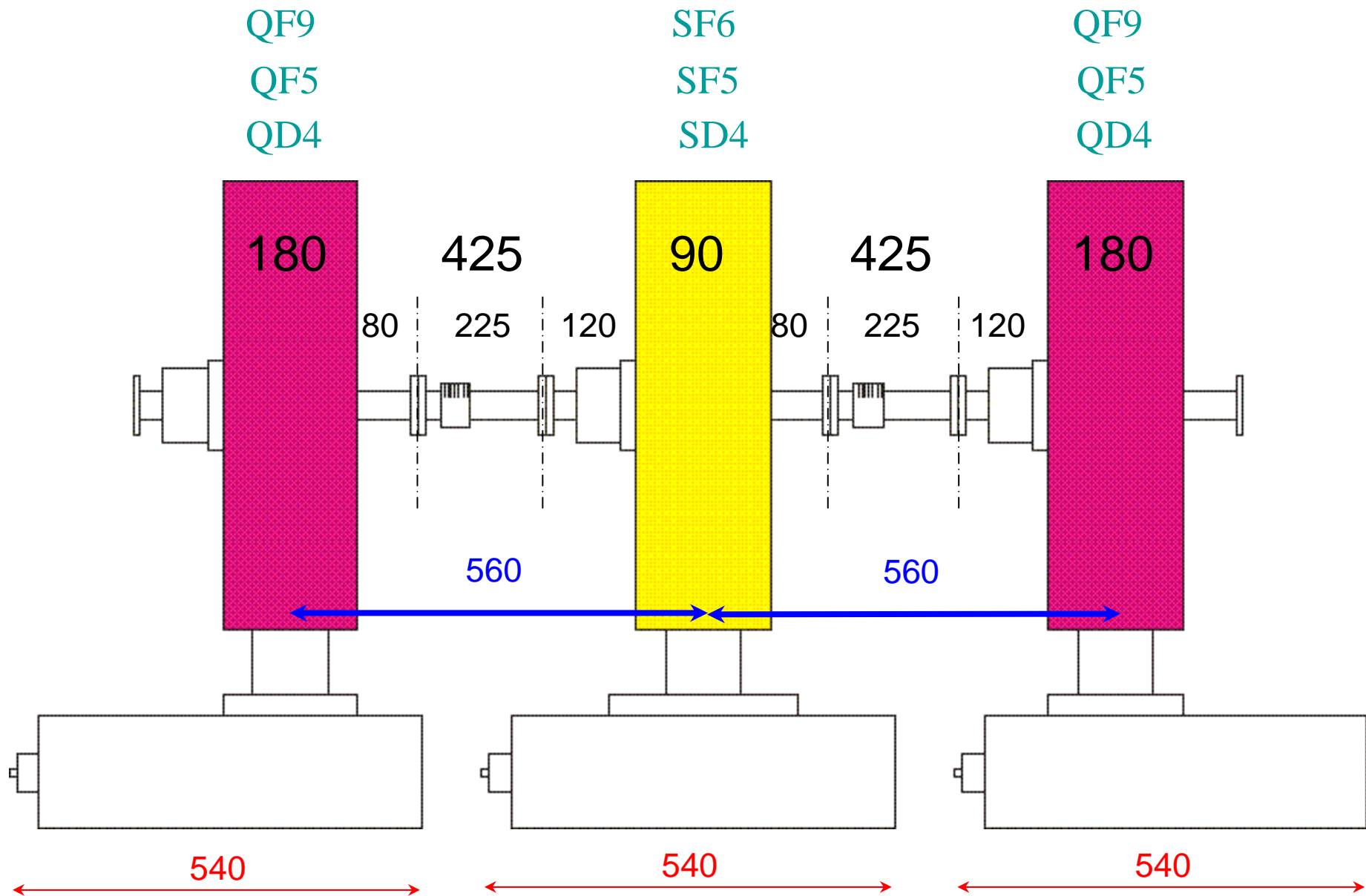

# Comparison of Fixing Method Bolting versus Polymer Concrete

## Polymer concrete

Mixture of epoxy and sand

Pre-polymer / hardener / sand = 2 / 1 / 15 in weight

**Strong binding force between metal and concrete**

Compressive strength > 80 N/mm<sup>2</sup>

Tensile strength > 30 N/mm<sup>2</sup>

Flexure strength > 50 N/mm<sup>2</sup>



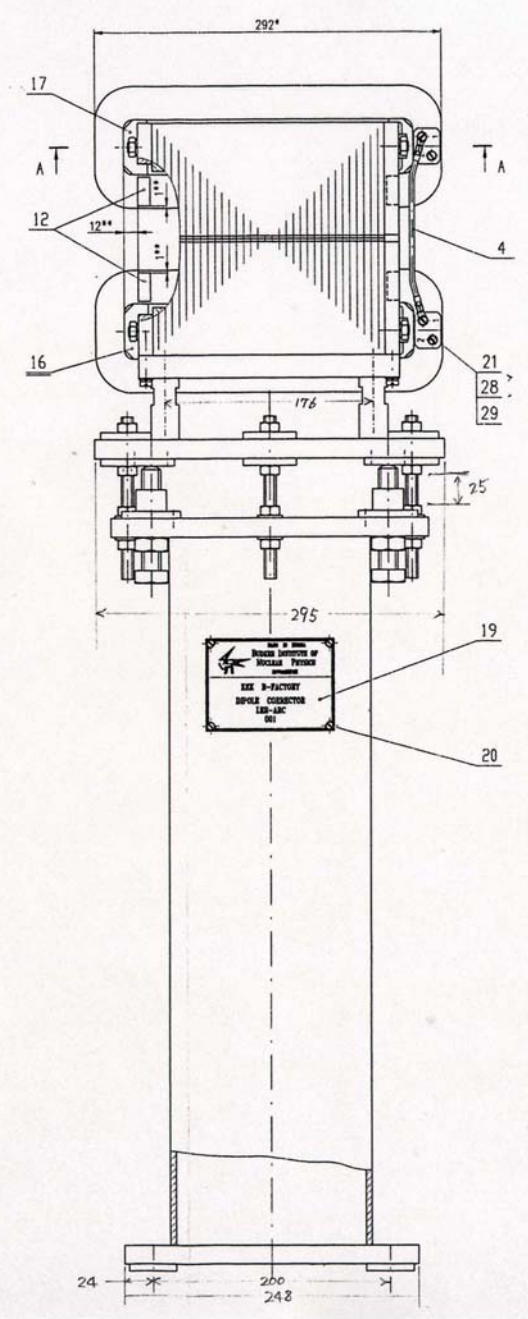
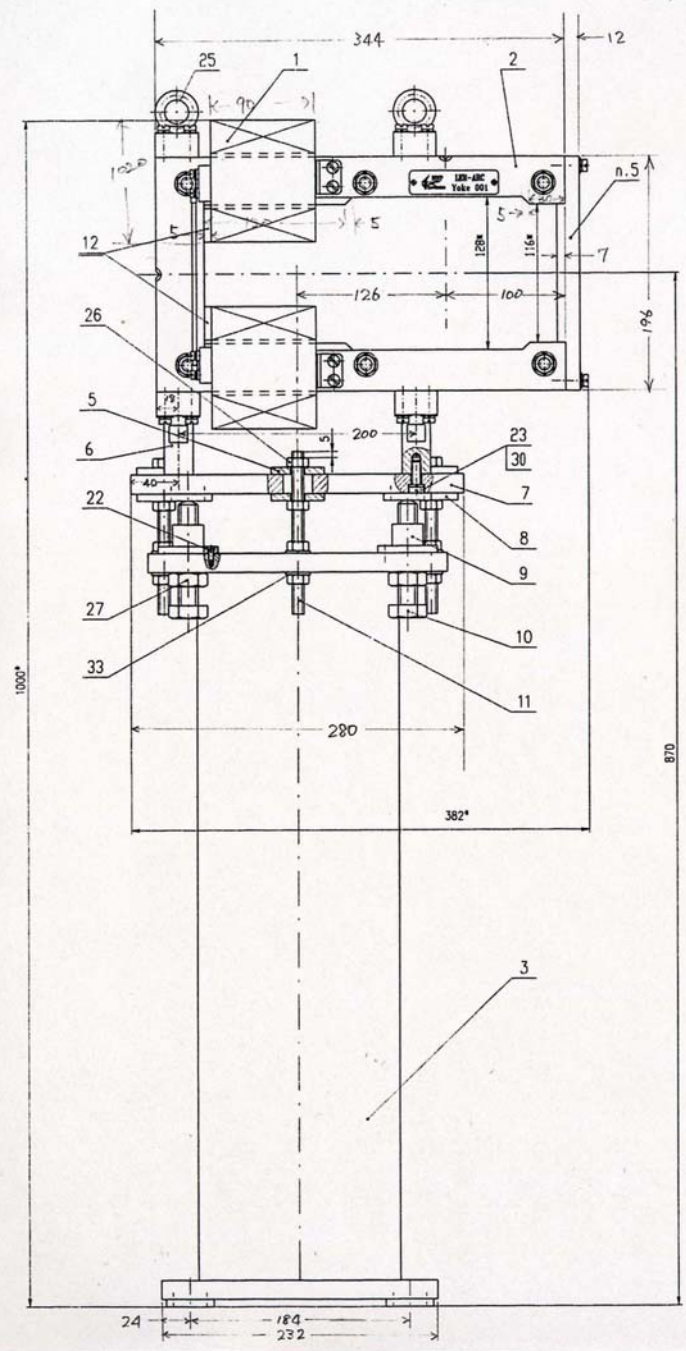

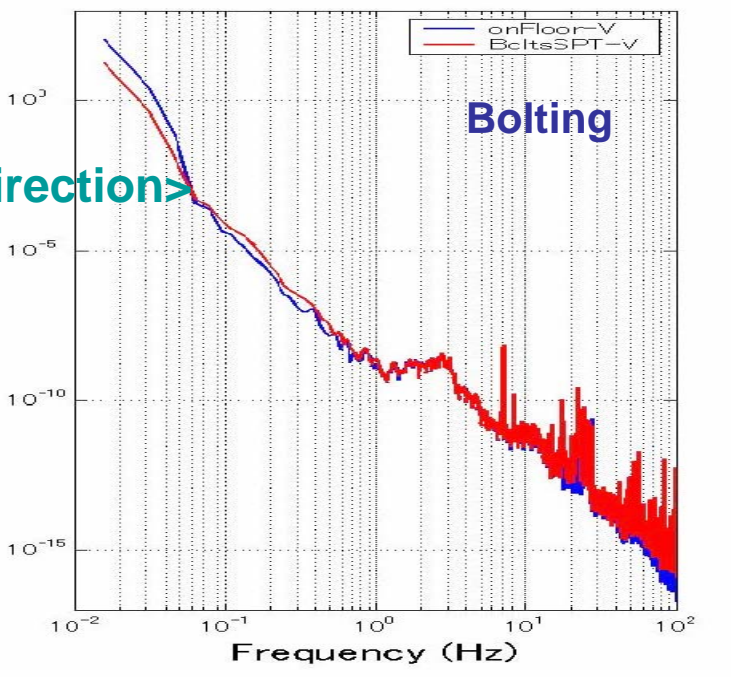
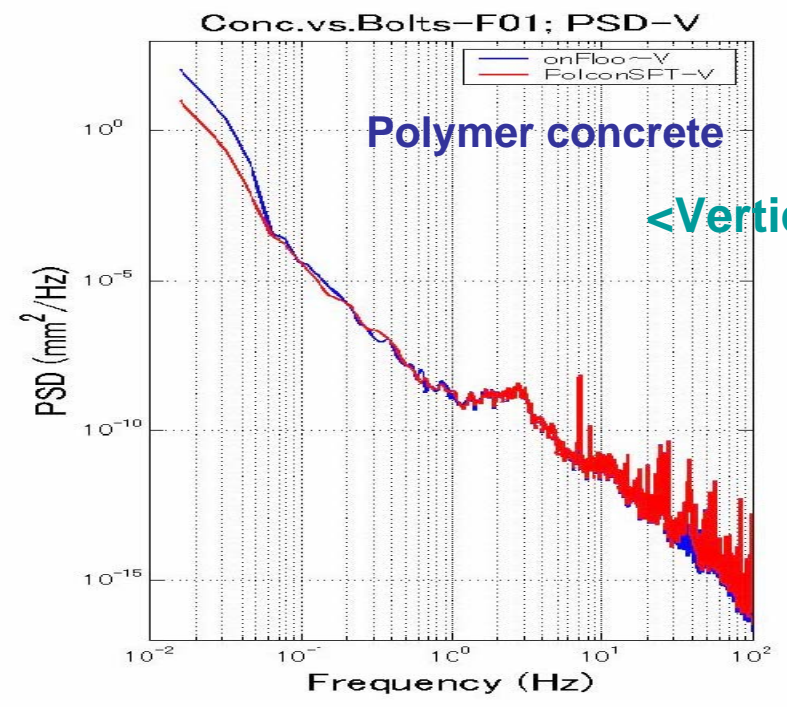
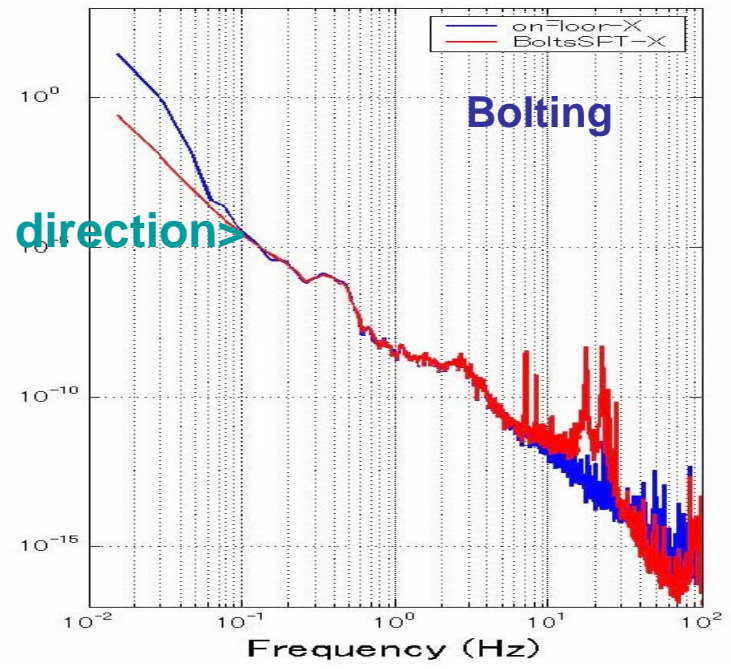
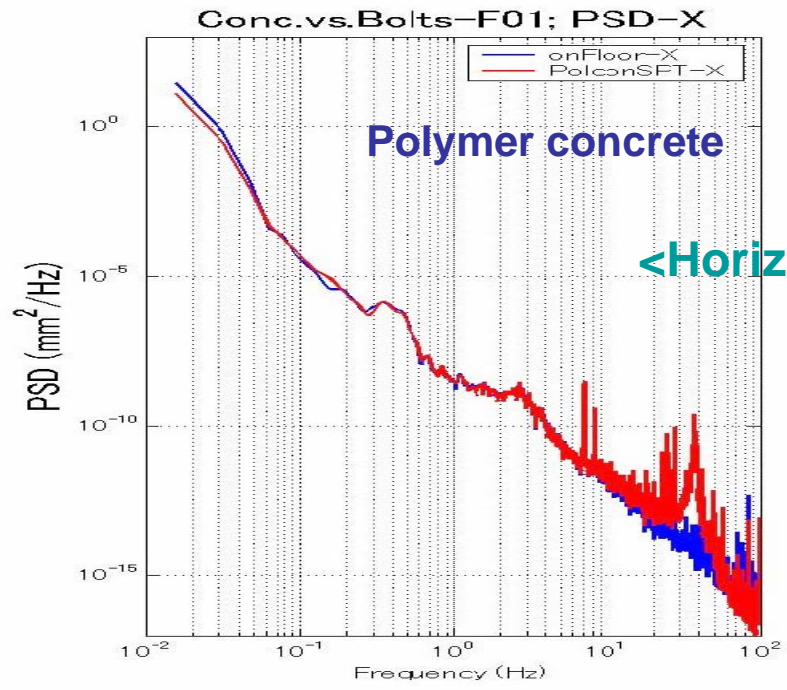



Conc.vs.Bolts-F01; Integrated PSD-X

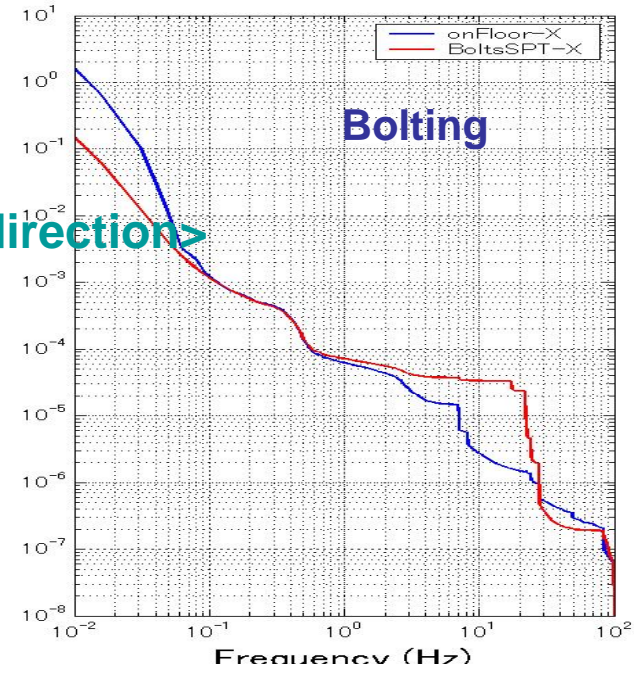
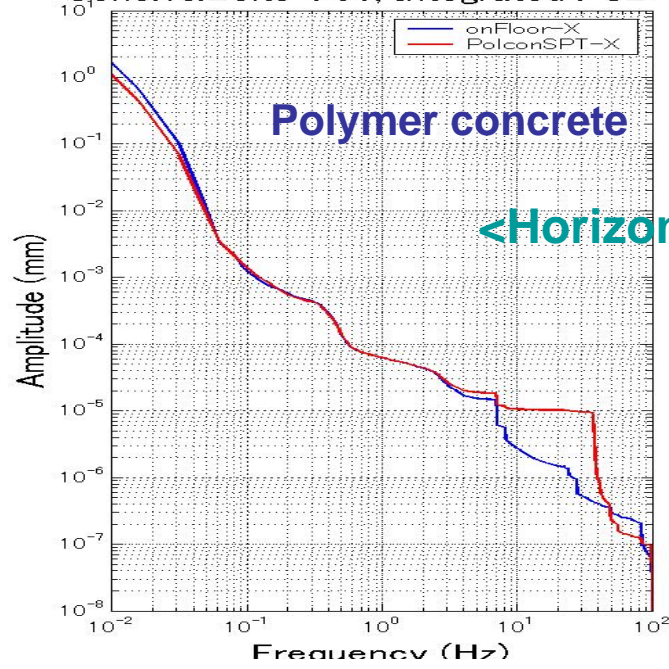

Conc.vs.Bolts-F01; Integrated PSD-V

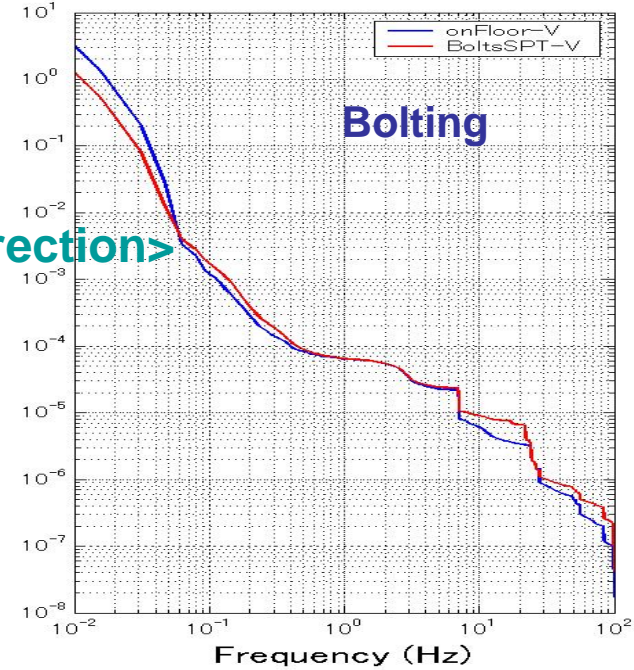
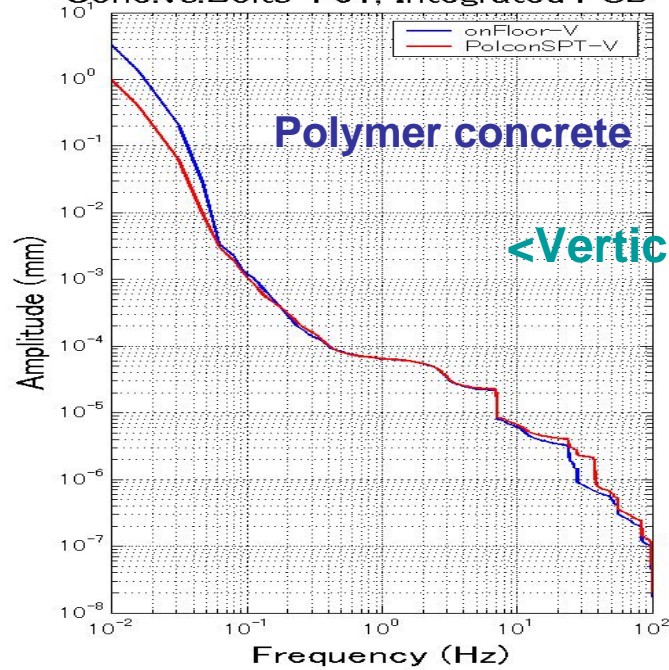

< - - >

# 【Measurement around the beam line (1)】

## - Measurement Points -

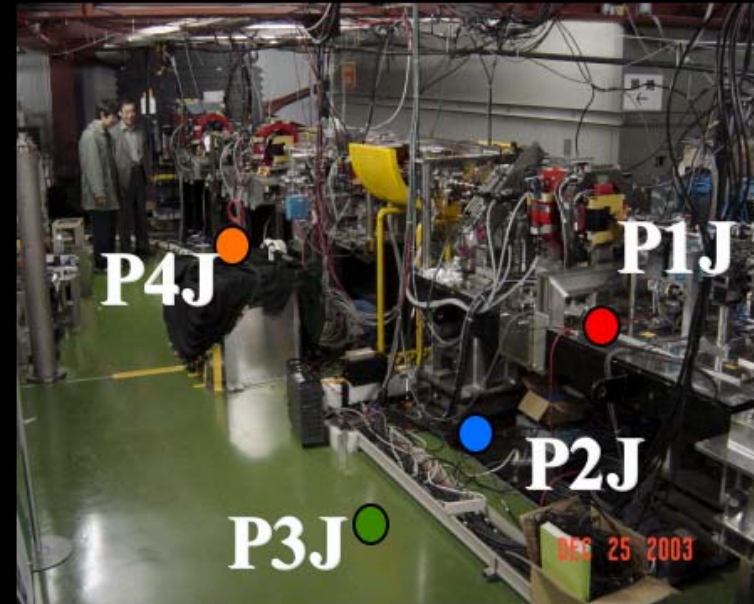
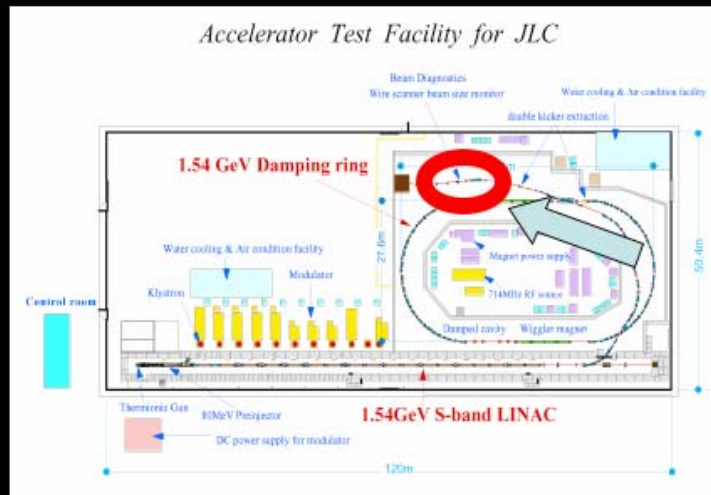

## - Observation -

2pm, Feb. 10, 2004 – 6pm, Feb. 11, 2004

30 minutes consecutive duration for 28 hours



# 【Measurement around the beam line (8)】

## “Power Spectrum Density (1)“

Component : X ( Orthogonal to the beam line )

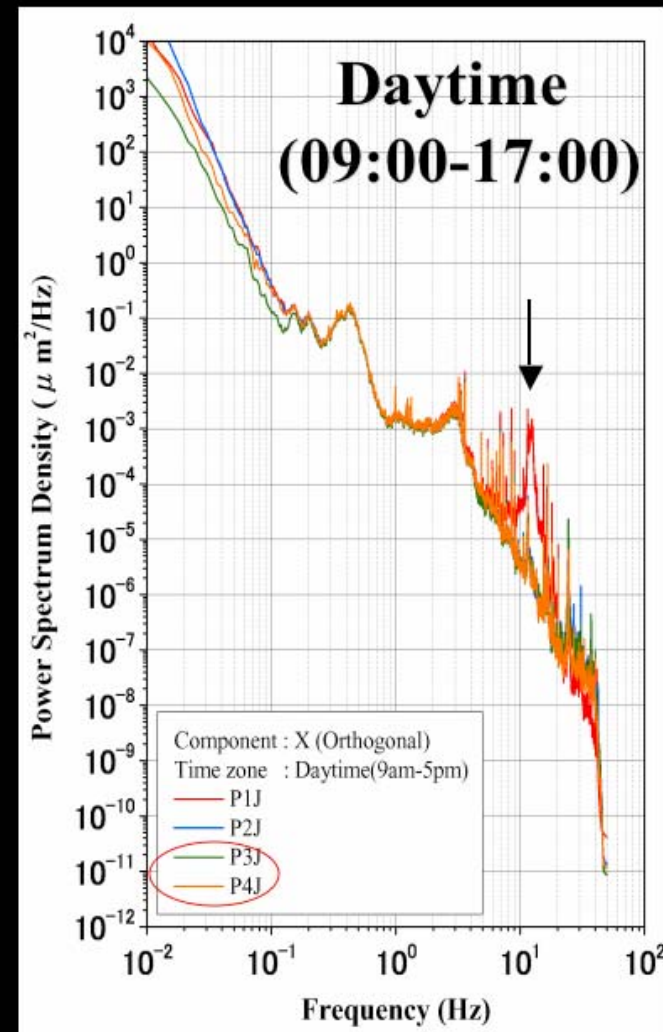
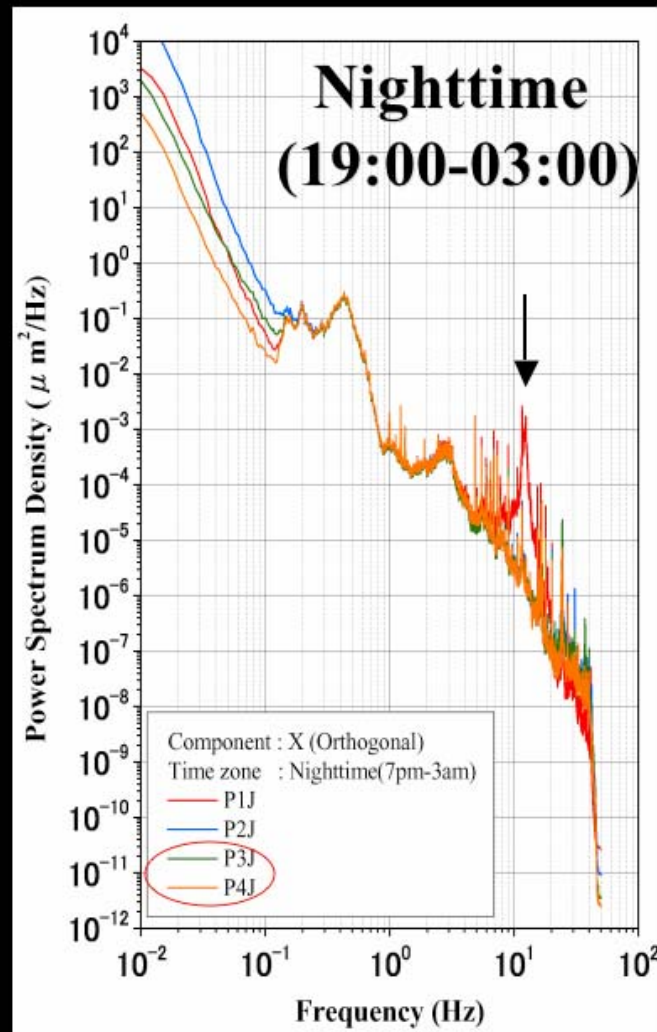

# 【Measurement around the beam line (10)】

## “ Power Spectrum Density (3) “

Component : Z ( Vertical )

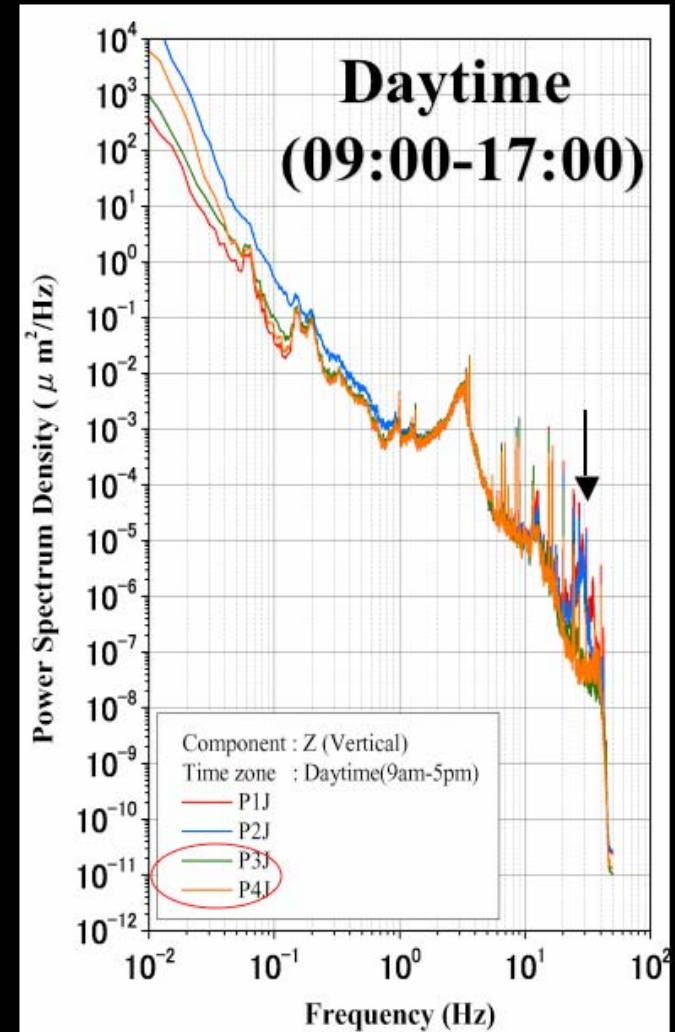
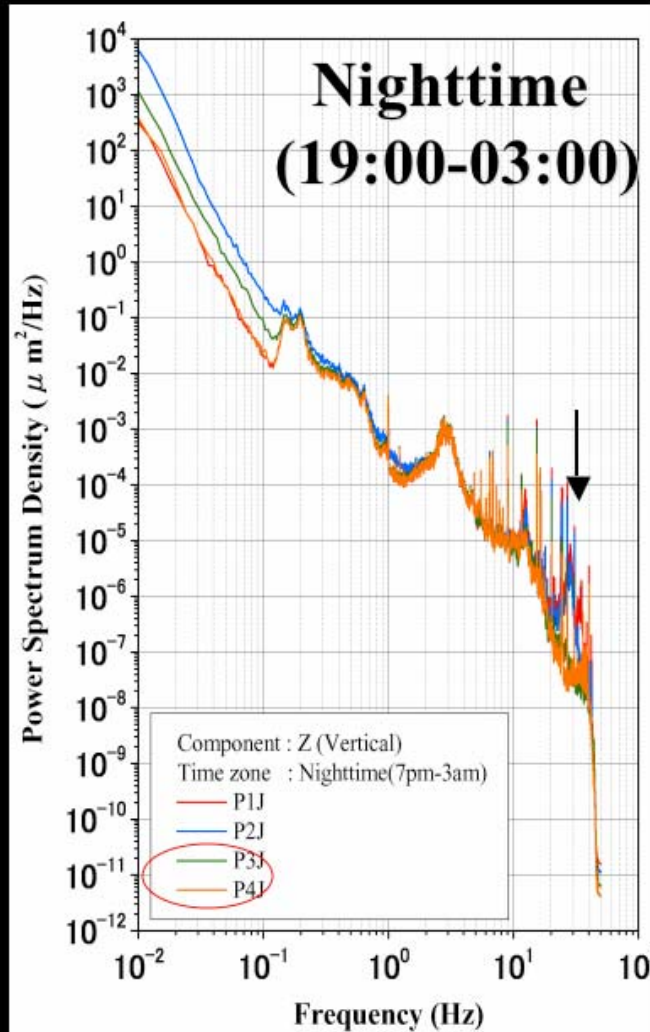



# 【Measurement around the beam line (11)】

## “ Integrated Spectrum (1) ”

Component : X ( Orthogonal to the beam line )

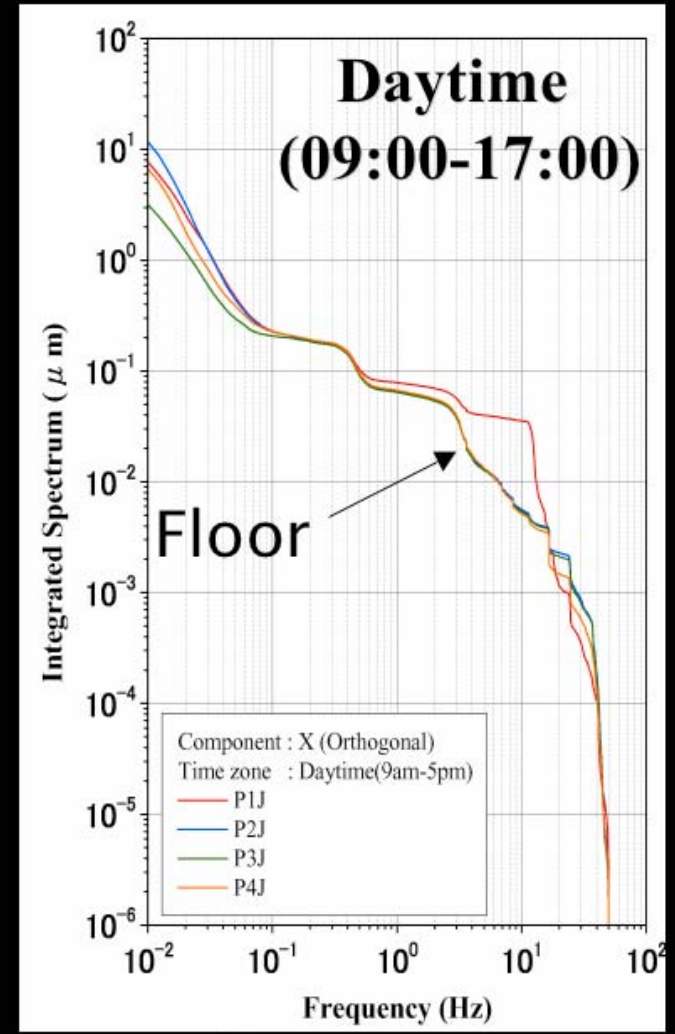
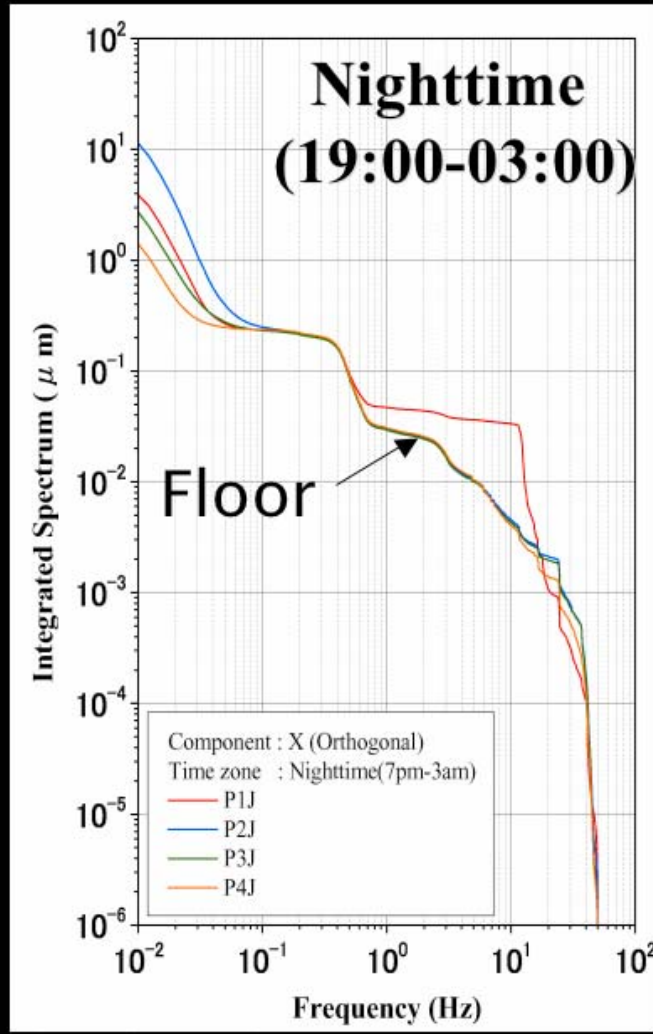



# 【Measurement around the beam line (13)】

## “ Integrated Spectrum (3) ”

Component : Z ( Vertical )

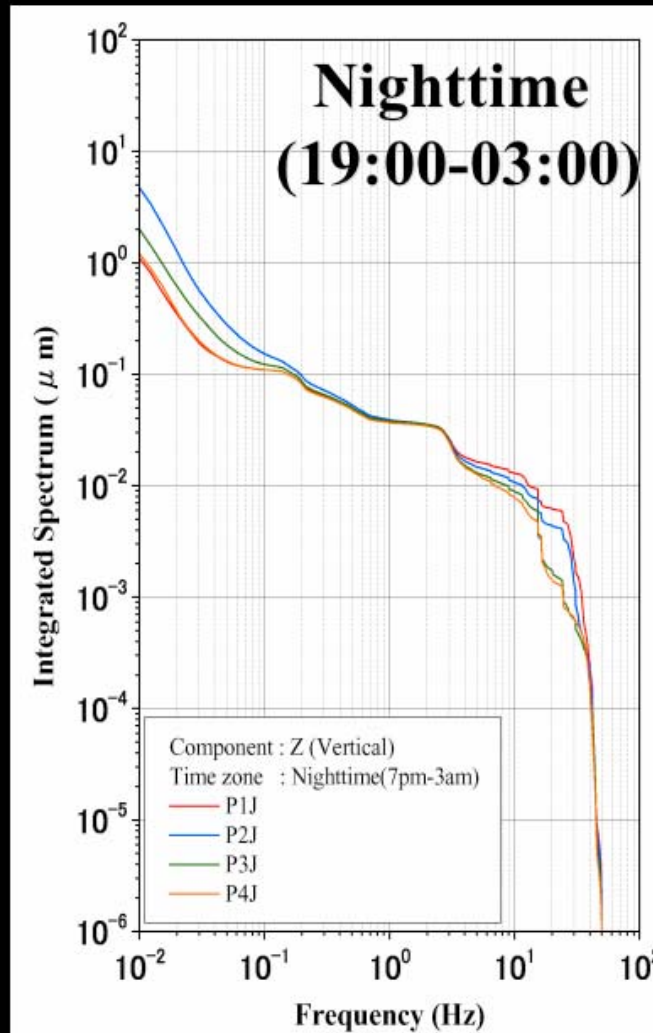

Chigasaki Research Institute

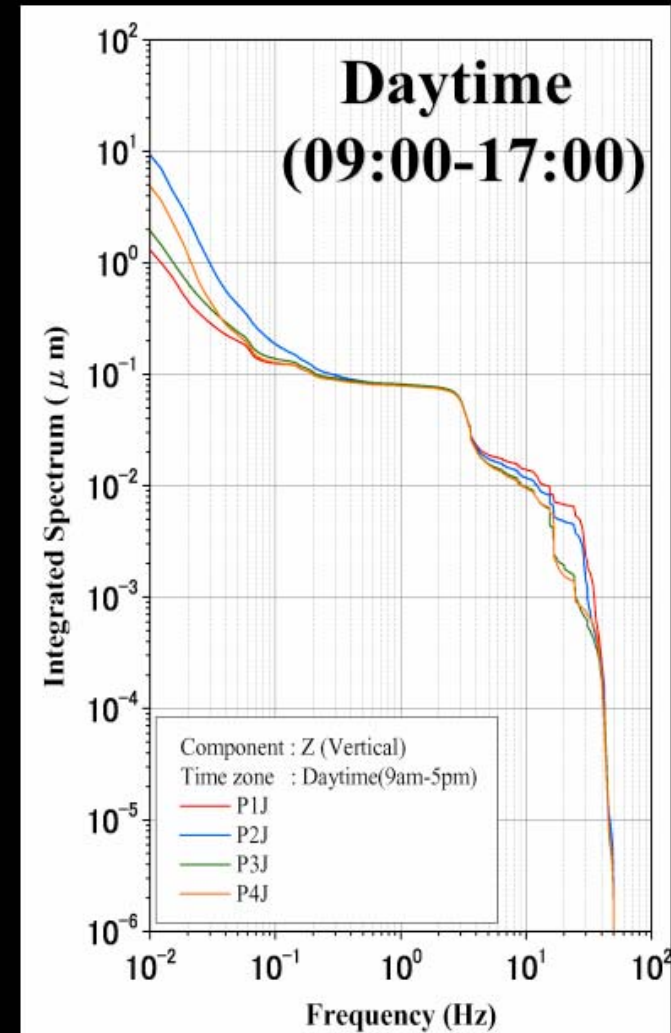

J-Power / Electric Power Development Co.,Ltd.

2. Measurement at ATF beam line & ATF clean room by H. Yamaoka using acceleration sensors at ~14:00 April 1, 2004.

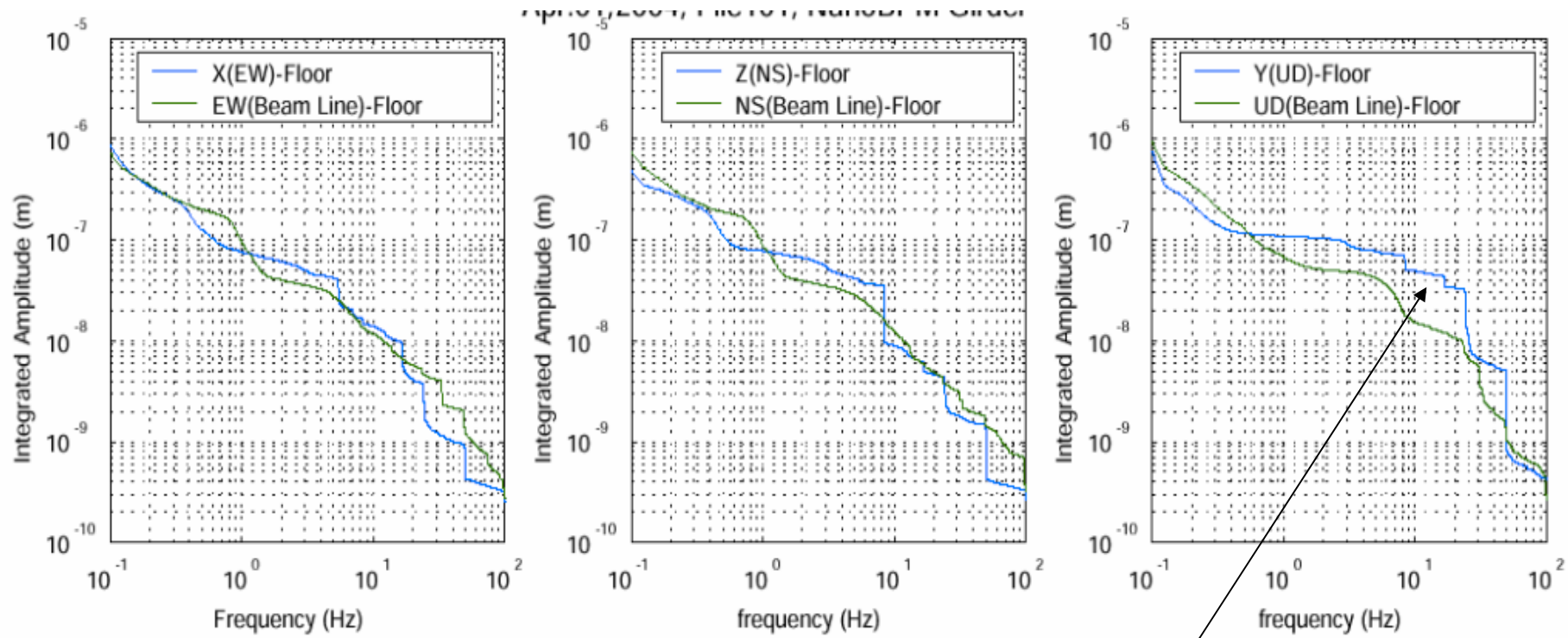

Integrated amplitude

Difference is clear in the vertical direction.



## Summary

Two methods to fix magnets were tested and compared. One is a traditional method using bolts, and the other one is that using polymer concrete.

Amplification factor is less in polymer concrete method (PCM) than bolting method in frequency region 4 - 20 Hz. Especially, amplification factor in PCM is about 1/3 of that in bolting method in horizontal direction.

On how to adjust the beam passage to the center of magnets, adjusting the beam by steering magnets seems to be preferable than adjusting magnet position by movers from view point of vibration problem if we care the vibration of Q-magnets at 10nm level in amplitude.