



Linear Collider Alignment & Survey

Metrology and Stabilisation

Andrea JEREMIE
LAPP-IN2P3-CNRS
Annecy

C. Adloff, B. Bolzon, Y. Bastian, L. Brunetti, F. Cadoux, G. Cougoulat, F. Formosa, N. Geffroy, C. Girard, A. Jeremie, Y. Karyotakis, J. Lottin, F. Peltier
R. Amirikas, A. Bertolini, W. Bialowons, J. Prenting, M. Schloesser, E-O. Saemann, D. Kaempfer

J. Coe, J. Dale, M. Dawson, J. Green, Y. Han, T. Handford, A. James, M. Jones, G. Moss, B. Ottewell, A. Reichold, C. Uribe, D. Urner, R. Wastie, S. Yang
G. Grzelak, B. Szczygiel



WP7 Metrology and stabilisation

METSTB

RTRS



StaFF

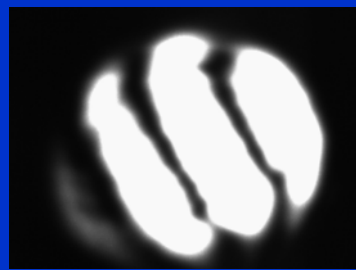

MSTBT



PGMS

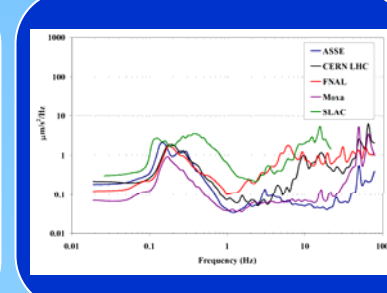



WP7 Metrology and stabilisation

METSTB

RTRS



StaFF

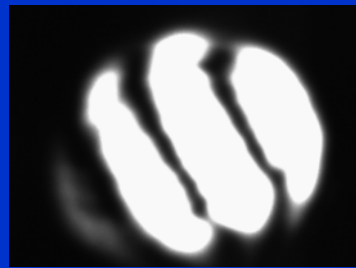

MSTBT



PGMS

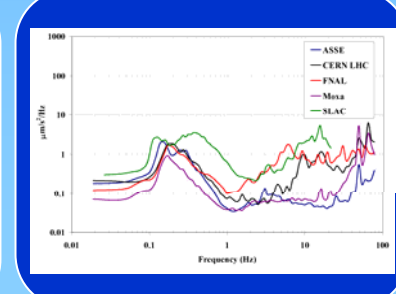



RTRS Concept (design overview)

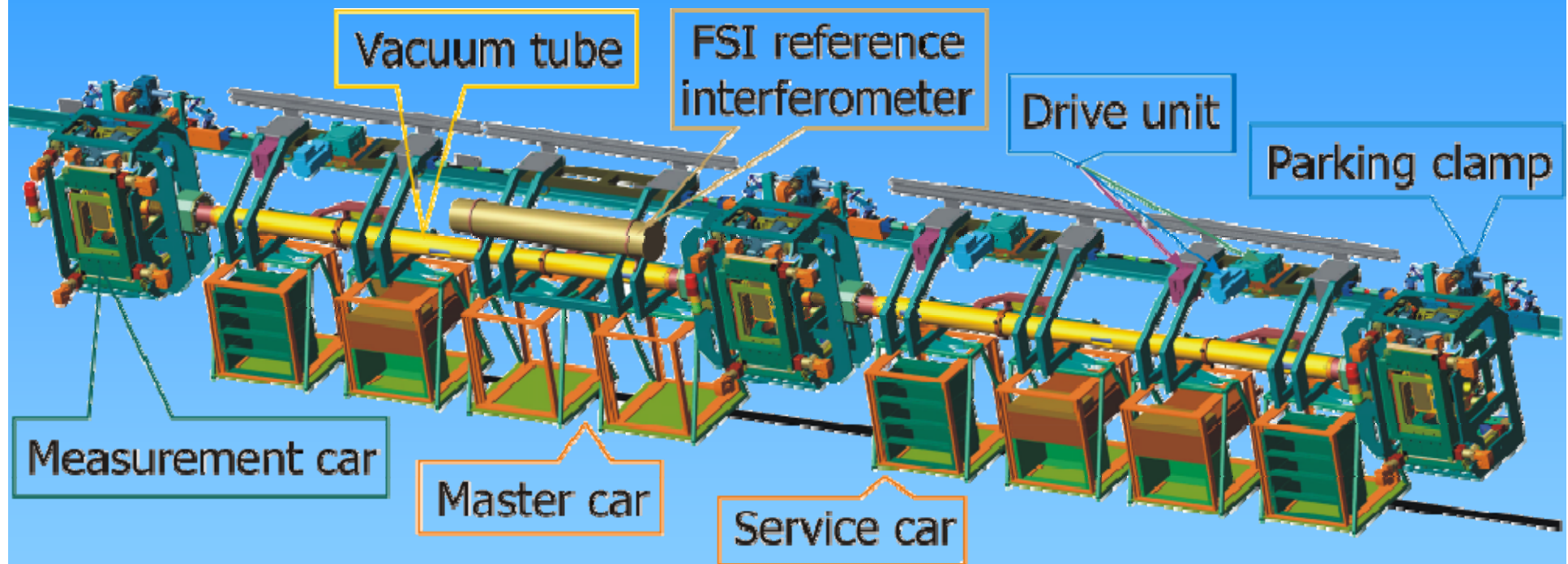



Implications for the ILC

- Cost Comparison (realistic approach, finding minimum in TCO (total cost of ownership) leads to very low down times of a day per year): starting point: 4 RTRS is a *practical* number

	RTRS pessimistic	Classical matching downtime of RTRS pessimistic	RTRS optimistic	Classical matching downtime of RTRS optimistic
#of teams	4	47	4	142
Downtime [days]	126	126	42	42
TCO with downtime [k€]	103,520	115,841 (120%)	35,797	61,804 (173%)
TCO without down time [k€]	2,776	13,770 (496%)	2,216	28,020 (1264%)

Estimates of the reference survey cost strongly favour the RTRS over classical survey methods

Expected Performance

- Both techniques agree well (only short distance simulated so far)

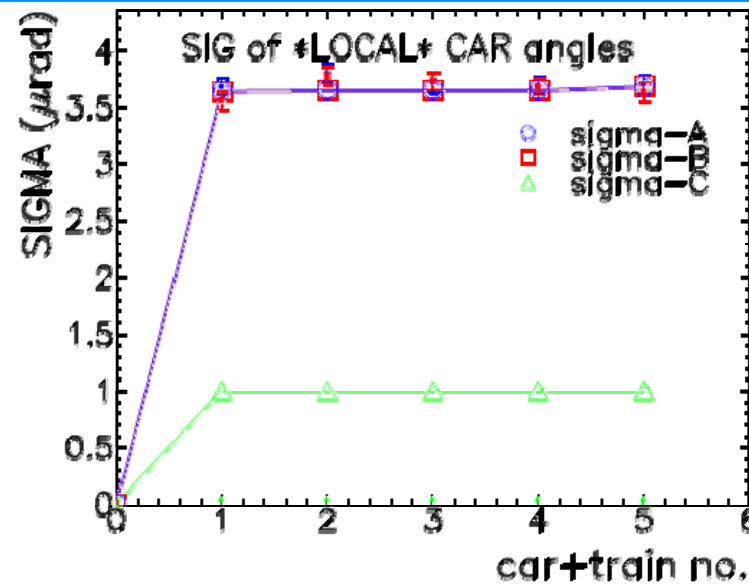
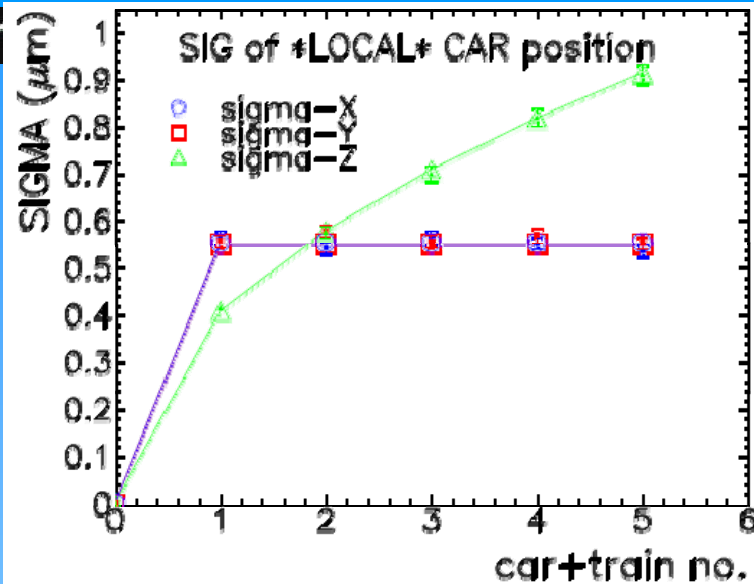

$A = \text{Rot}_x$
 $B = \text{Rot}_y$
 $C = \text{Rot}_z$

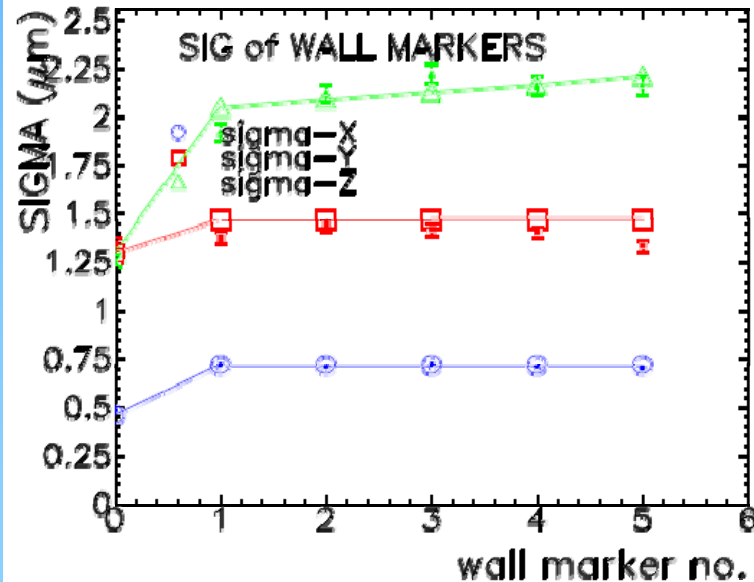

- assuming intrinsic resolutions:
 - CCD: $\sigma_{\text{CCD}} = 1 \mu\text{m}$
 - FSI: $\sigma_{\text{FSI}} = 1 \mu\text{m}$
- 1000 Simulgeo runs, simplified model, no errors on calib. const. (INT/EXT-FSI, CCD, BS)
- open markers: Matrix calculation (analytic)
 solid markers: Errors from Monte Carlo (statistical and systematic errors)

LSM Reconstruction

- Sensitivity study, no calibration errors, only 1 micron spot position errors, fast linearised reconstruction

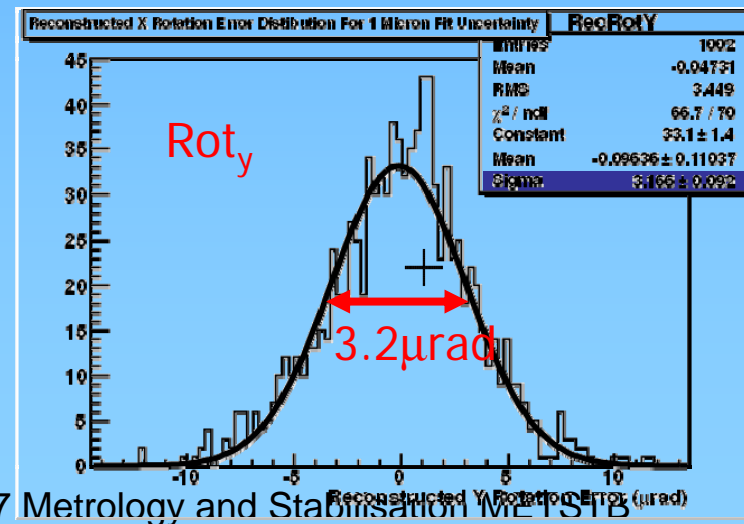
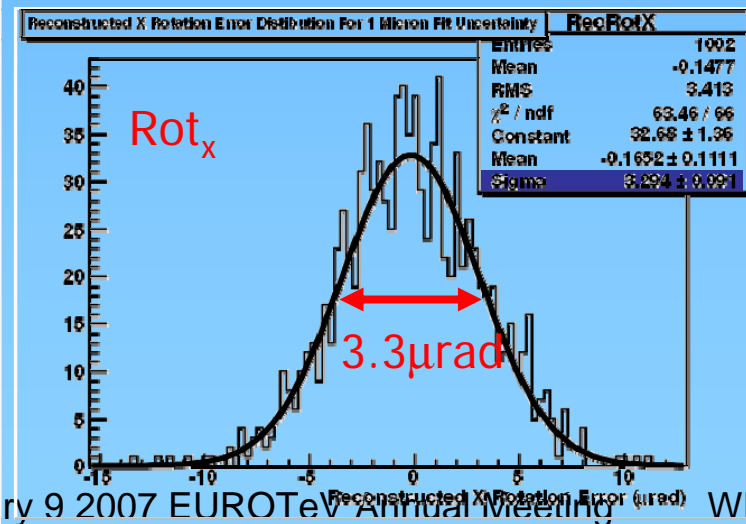
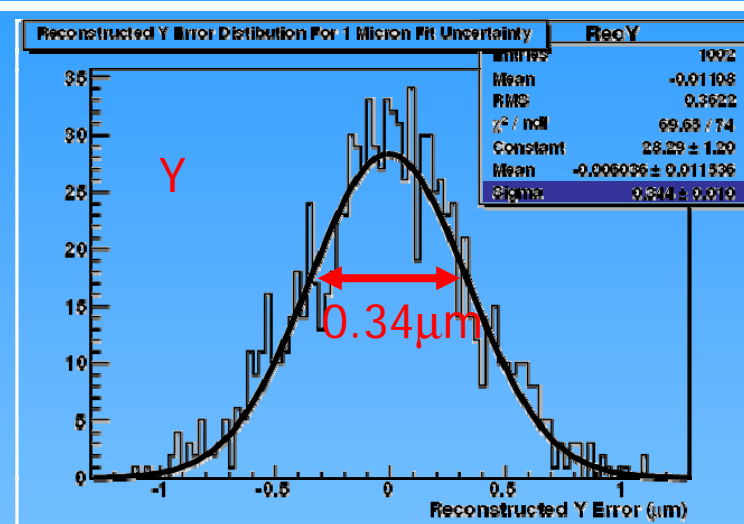
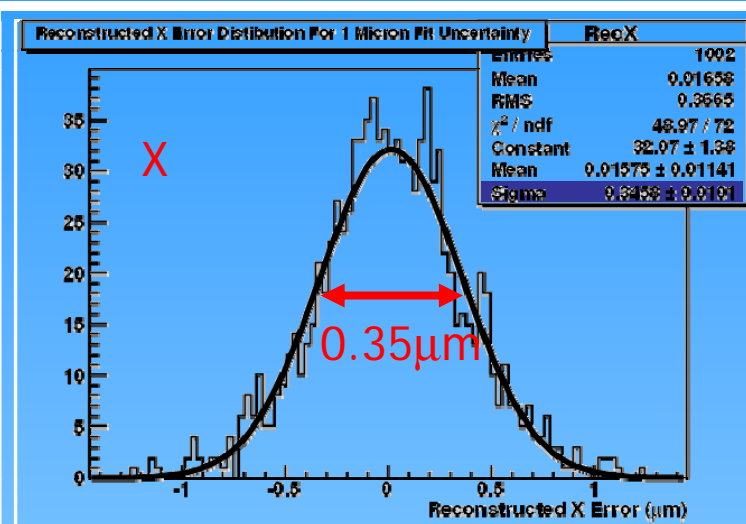

RTRS Installation at DESY

- Service, measurement and master car joined into one RTRS
- Drive system installed and operational
- Power and interlocks installed
- Motion stage systems in measurement cars operational
- Parking brakes operational
- Vacuum system 95% installed
- Infra structure complete
 - air conditioning
 - interlocks
 - networks
 - rail

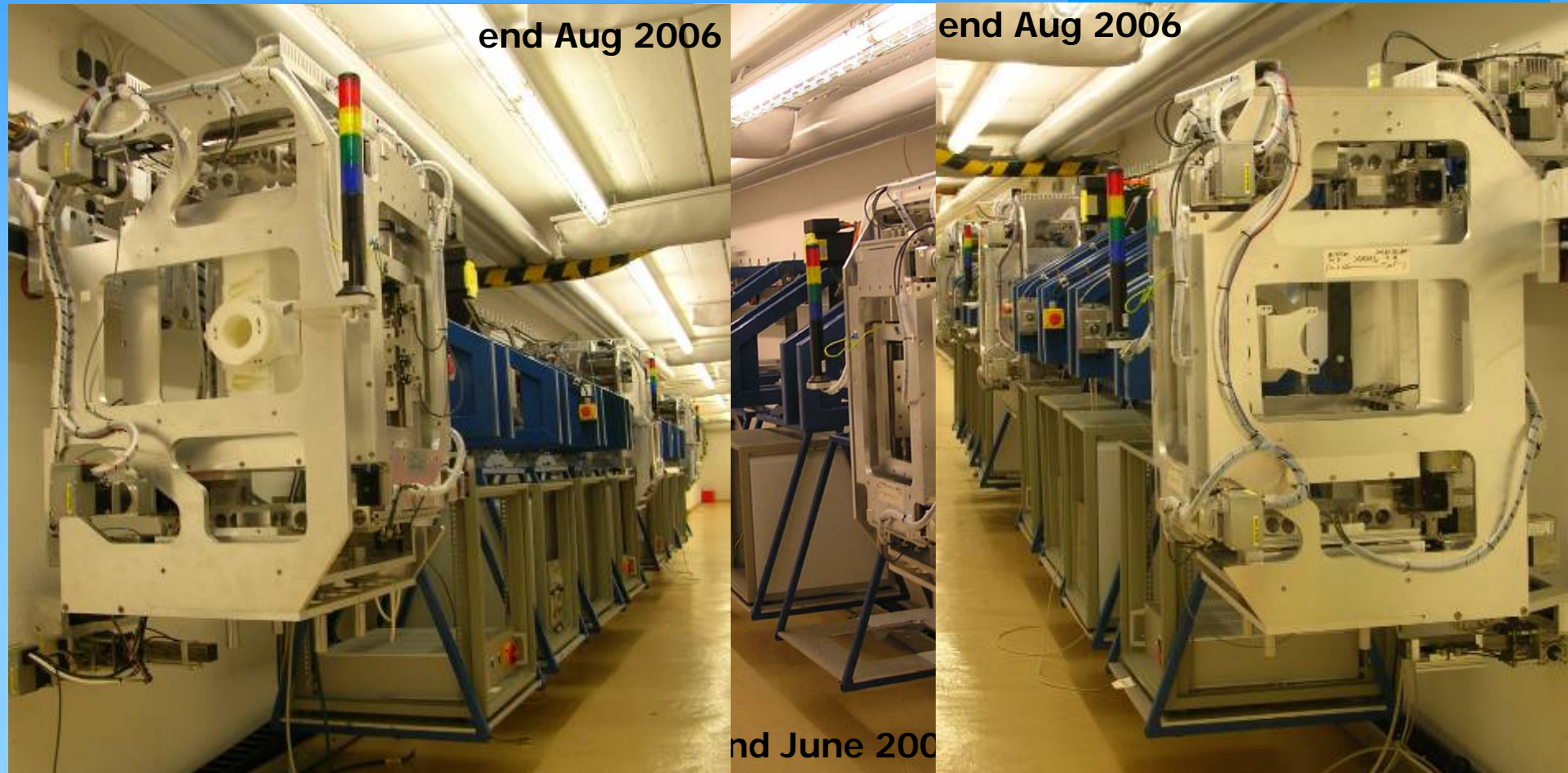



WP7 Metrology and stabilisation

METSTB

RTRS

StaFF

MSTBT

PGMS

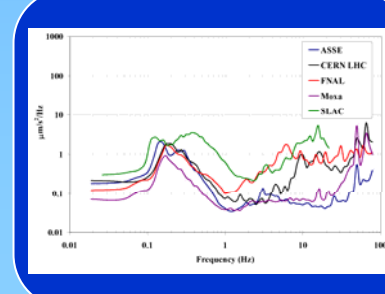
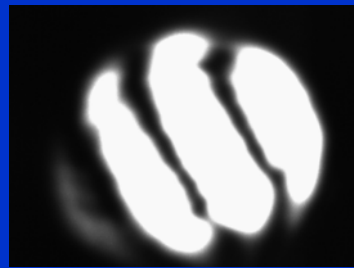



Michelson : realised in the lab

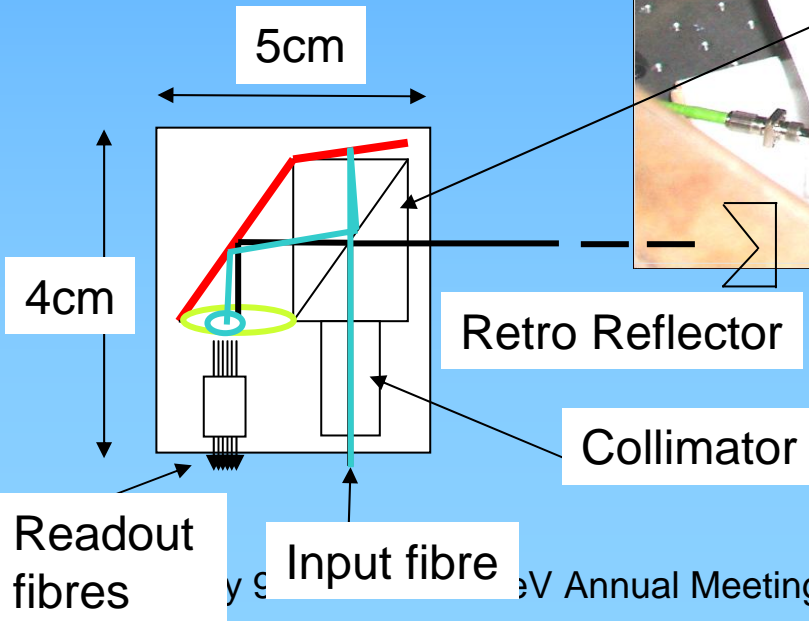
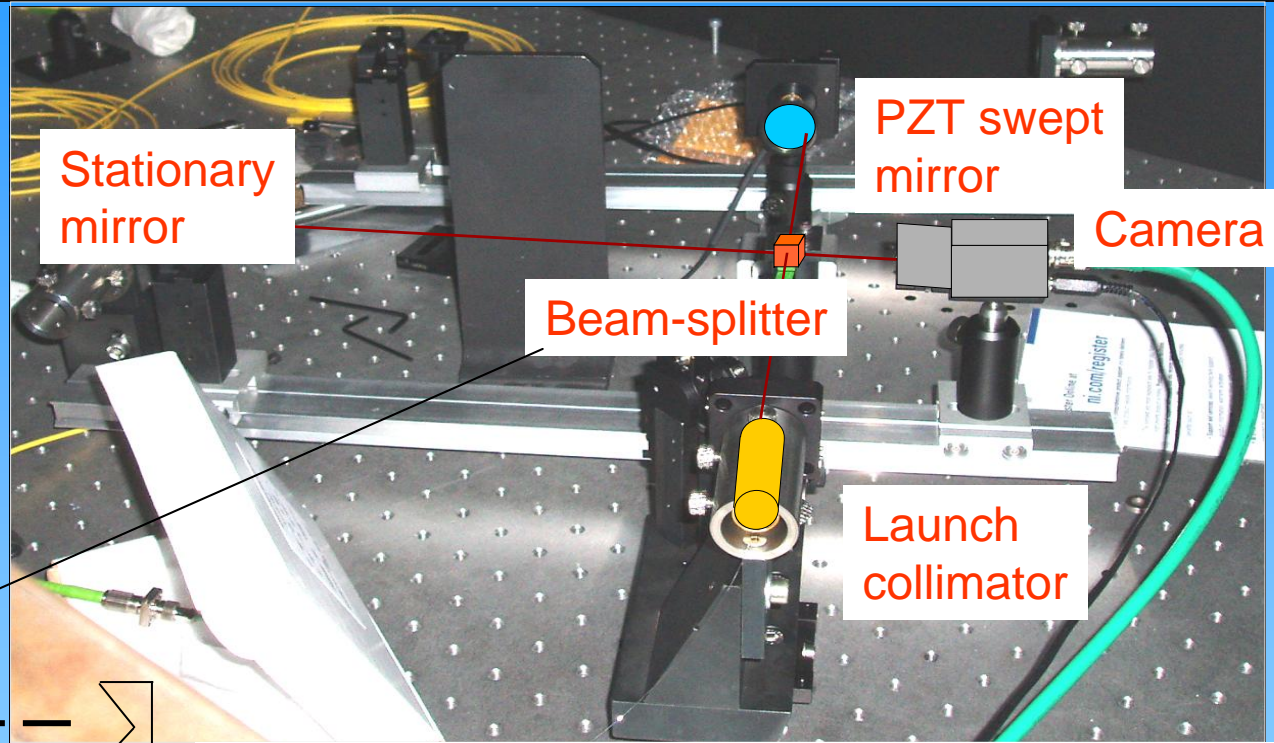

Work on compact Interferometer head
 Shown here using 2cm optics
 1cm optics likely to work. According to Zemax simulation diffraction should not be a problem.
 Need to solve problem how to produce 0.2 degree angle for mirror on beam splitter cube

Michelson : Camera view of mirror sweeping



Use modified
Carré
algorithm to
extract
wrapped
phase for
each channel
 $1\sigma \sim 40$ mrad
equivalent 10 nm



Move to ATF2

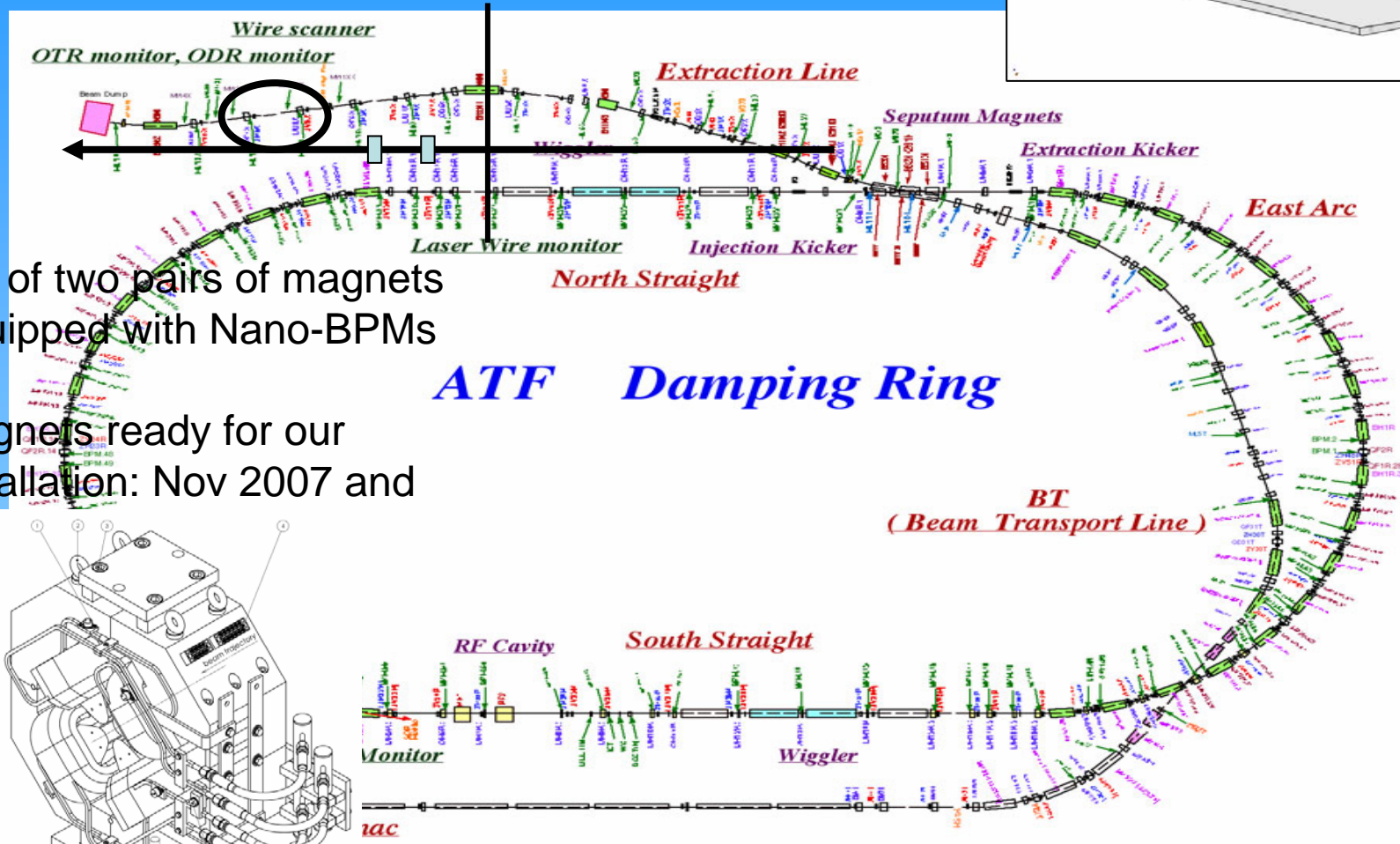
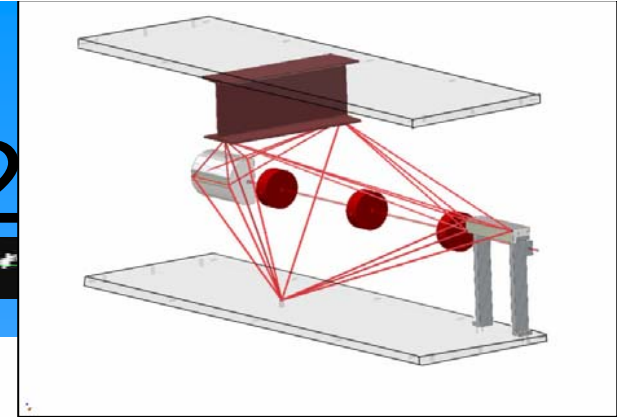

- Set of two pairs of magnets
- Equipped with Nano-BPMs
- Magnets ready for our installation: Nov 2007 and started

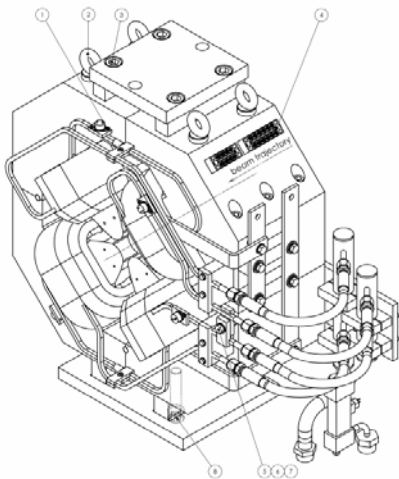



WP7 Metrology and stabilisation

METSTB

RTRS

StaFF

MSTBT

PGMS

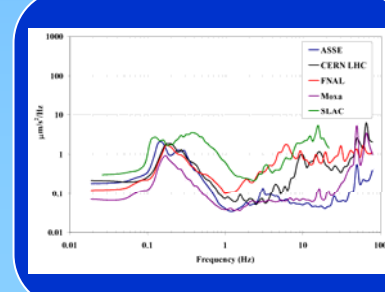



WP7 Metrology and stabilisation

Stability Within a cryomodule



Stability Within the Module

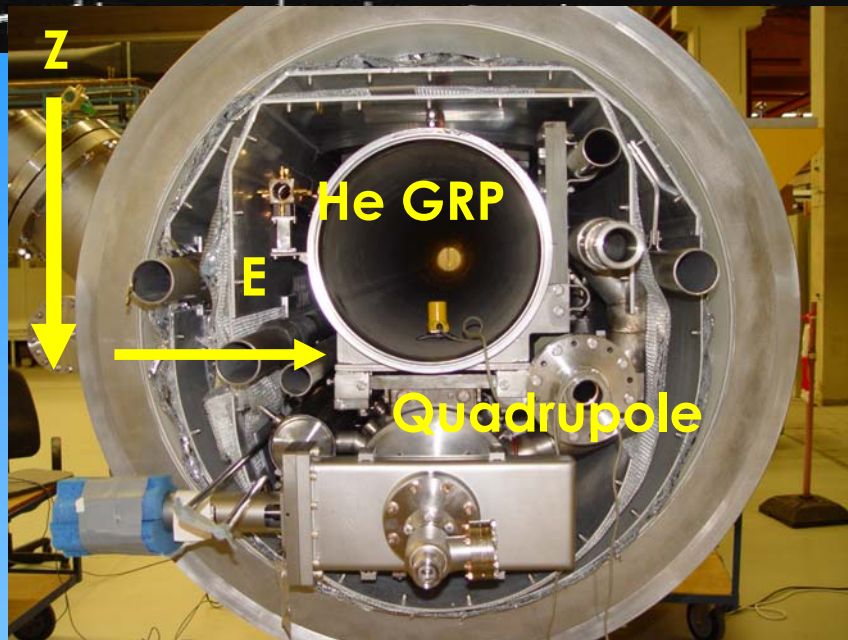

Sensor positions (in V + HT):

- Vessel top vs. He GRP
- He GRP vs. quadrupole
- Vessel top vs. quadrupole
- Reference measurement on the girder/floor



Stability Within the Module

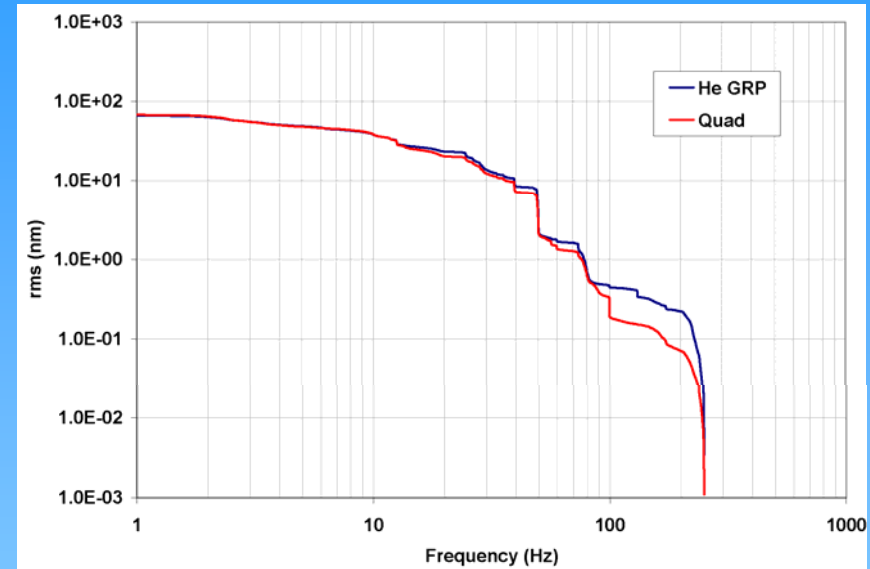
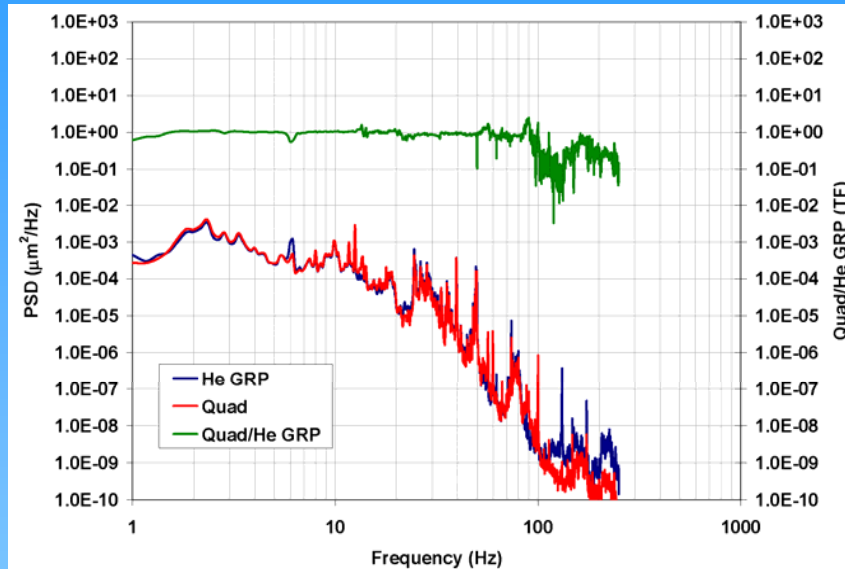
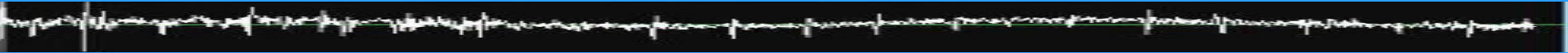

PSD (V) of module 6 (as placed on its test stand) on 25 August 2006, quad vs. He GRP

Integrated PSD (rms) @ $f > 1.7$ Hz:
quad/He GRP=67/65 ~1

Conclusion: Throughout our measurement program, stability within the module (quad vs. He GRP, quad vs. vessel top) is consistently observed within a 20% window maximum.



Reproducibility of Our Data

In order to check reproducibility in our measurements, a single frequency was injected in the system (i.e. floor and hence the module), via a shaker, in both vertical and horizontal transverse directions and the rms of the signal was measured via gephones (@ $f > 2$ Hz)

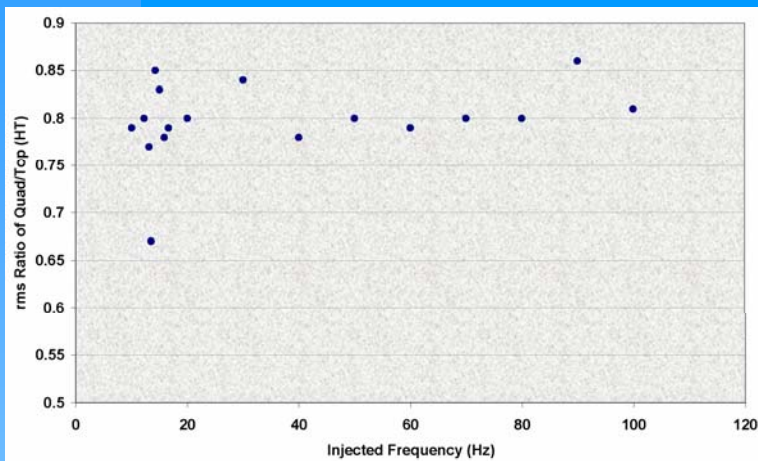

Quad/Top @ 2 Hz in HT

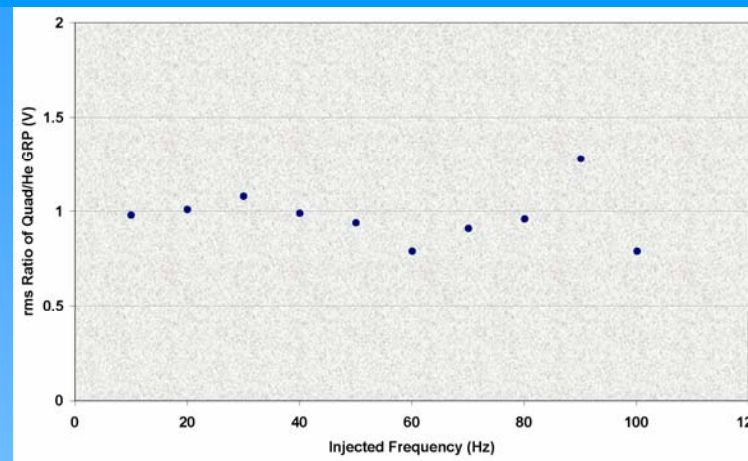

Quad/He GRP @ 2 Hz in V

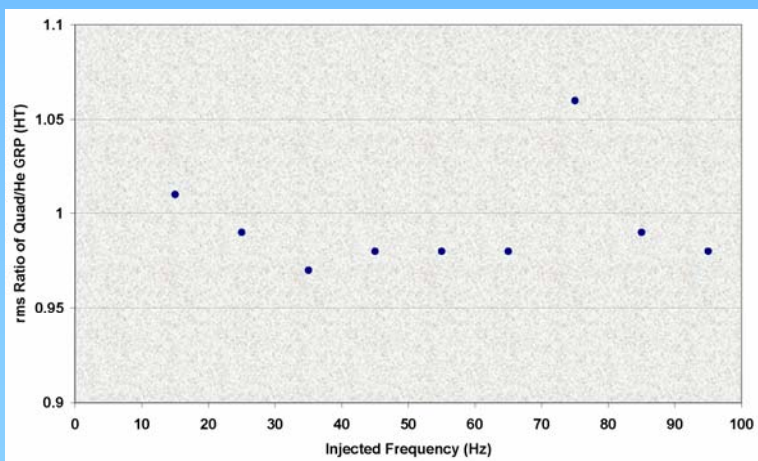

Quad/He GRP @ 2 Hz in HT

Conclusion: Our measurements within the vessel (quad vs. He GRP and quad vs. Vessel top) are reproducible.



WP7 Metrology and stabilisation

Supports and tunnel configuration

Comparison of Ceiling vs. Floor of a Shallow Tunnel (HERA)

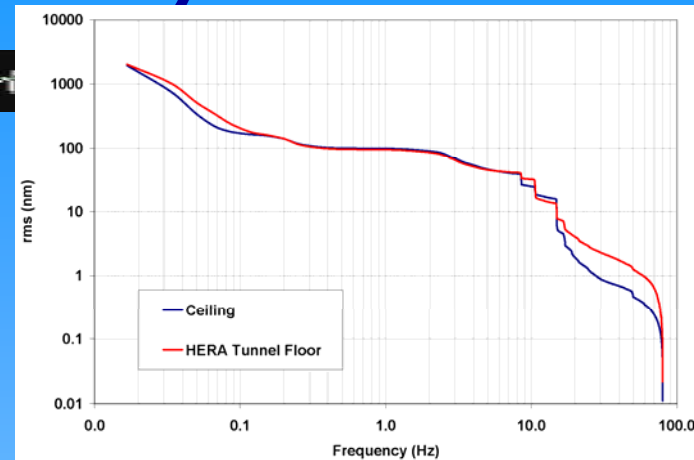
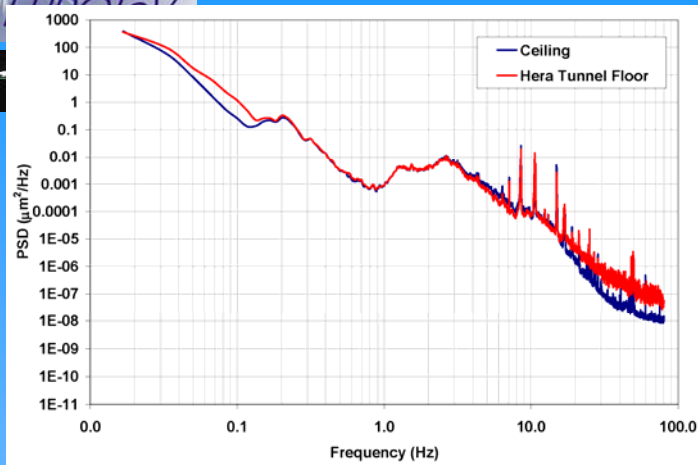

Average psd (V) and integrated rms of motion (nm) > 1 Hz; @ 1 Hz, ceiling/floor=99/95 ~0.96, i.e., a difference at a 4% level is seen. Same result is obtained for the horizontal directions.

Conclusion: High f noise (> 10 Hz) is detected in both ceiling and floor, or as it were two parallel tunnels at a distance of ~ 10 m. However, low f noise (< 1 Hz) was detected on the floor only, or as it were a 'service tunnel'. However, in all these cases (machine in a single tunnel whether on the ceiling or on the floor, or two tunnel solution), facility noise should be damped/minimized.

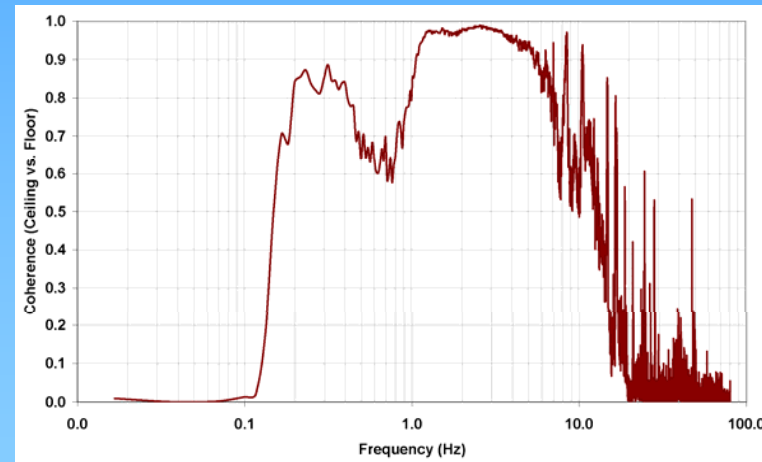

Coherence signal between the two sensors placed at a distance of ~7 m. Good coherence (> 0.5) upto 13 Hz is

seen.

Quad motion ingredients

EUROTeV



Facility noise

(near-field sources like insulating vacuum pumps, fans, compressors, etc. produce huge vibrations with peaks in 10-50 Hz band)

Ground motion

(broadband excitation + microseismic peak around 0.15 Hz + cultural noise >1 Hz; correlation length dependent on geology and civil construction)

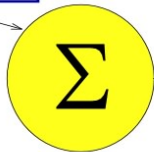

shortcut

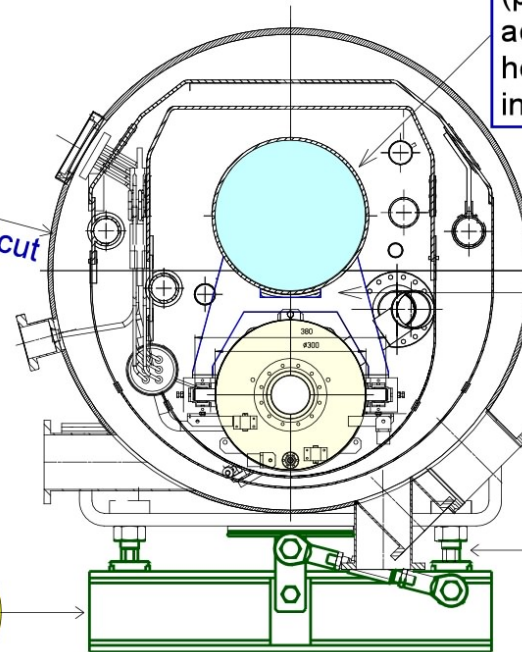

End-section of a Type III+ cryomodule

Cryogenic system

(presently unknown effect; broadband acoustic noise induced by the 2K helium gas flow + pressure oscillations in the liquid helium feed lines)

Quad support

(in present cryo's the quad+cavity string is supported by the big He gas return pipe (GRP); already reliable design as shown in this work)

Cryomodule 'normal modes'

(the module on its supports/floor behaves like a compound pendulum; resonant frequencies depend on the stiffness of the support, on the module mass and on the interface between the support and the tunnel floor/ceiling. Easier design in vertical with modes >50Hz)



LHC Low β Quadrupole



LHC low beta quadrupole next to ALICE Interaction region



View of the alignment jacks. Note the enlarged contact section and the extra layer of concrete.

Length	~ 9 m
Weight	17 tons
Cryostat diameter	~ 1 m
No. of jacks	3 with enlarged footing section
Cold mass support	Full cross section collars



Composite spider-like cold mass support, designed for better rigidity.



LHC Low β Quadrupole



Effect of the support foundation



vessel socket vs jack base

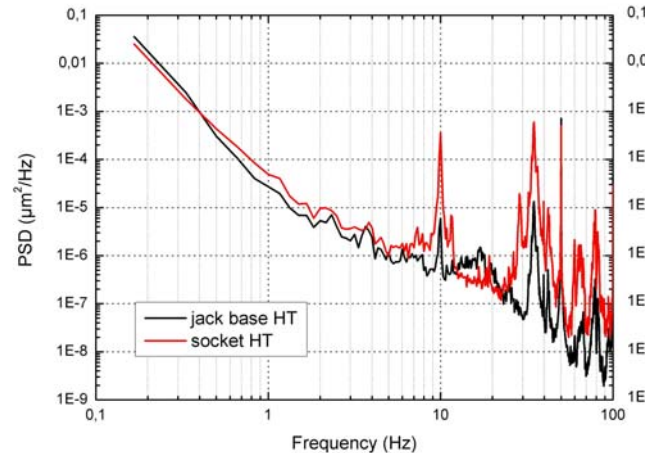

- the transverse mode structure already visible at the interface between the jack and the concrete pad, but not in the floor
- the enlarged contact surface produces significant benefits on the dynamic stability of the module



Vessel socket vs floor

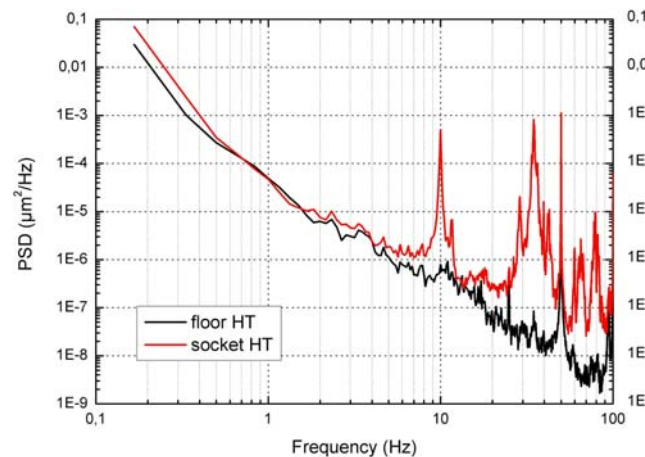

the results of the measurements on this short quadrupole cryostat look promising for the use of the alignment jacks for the ILC linacs, after suitable modifications



XFEL-hanging modules



XFEL Tunnel layout

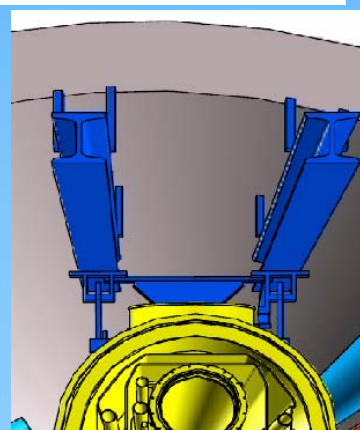
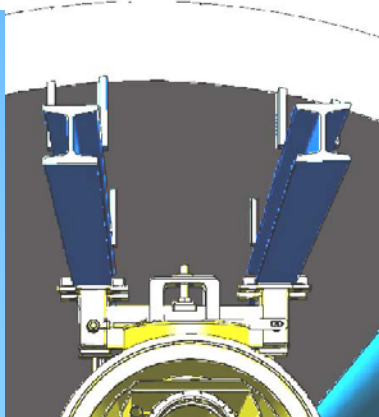
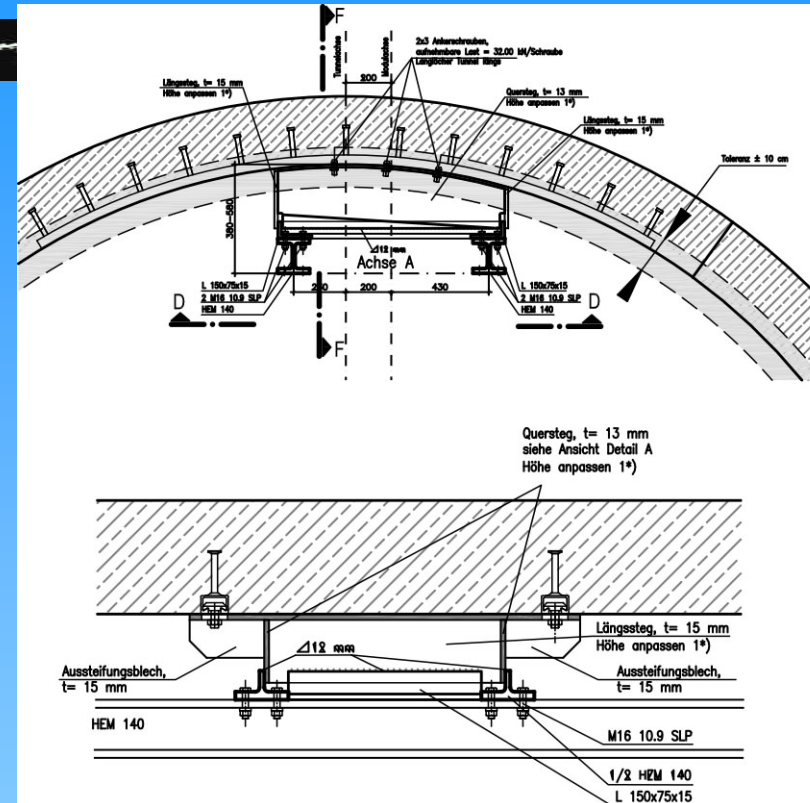
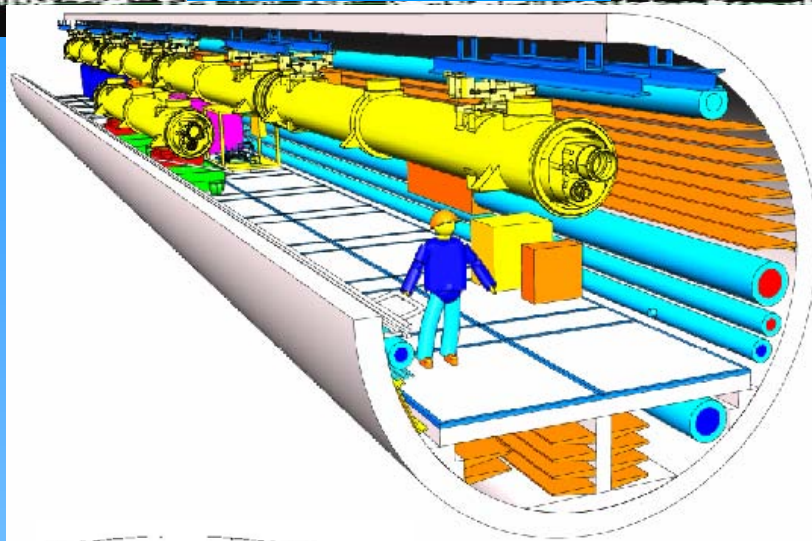

Alignment/support jigs clamped to the rails

*Courtesy of Amberg Engineering

Connection boxes + continuous rails as interface between the ceiling and the module string.



XFEL-jigs design

Two alternative design proposed and tested for vibrations by our group



Pull Rod Version

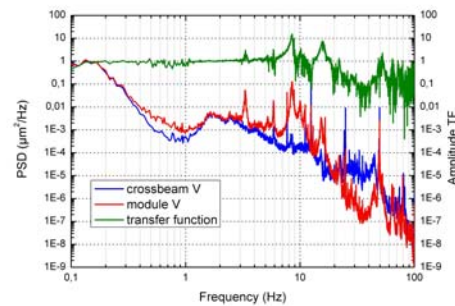

Bolt Version

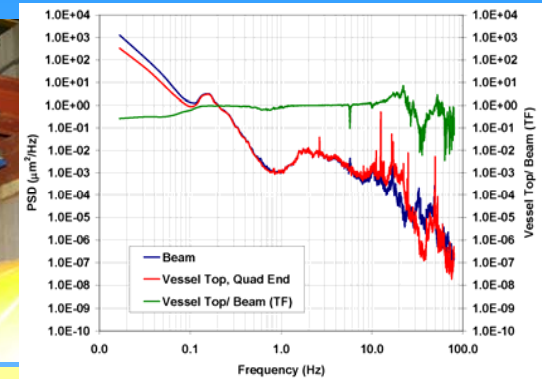

Concept

The module is suspended by four M24 rods; three adjustment rods provide knobs for alignment in the horizontal

Advantages

Cheap, quick installation and alignment

Drawbacks

Horizontal and vertical adjustment coupled; Internal resonances at low frequency

Horizontal transverse/Vertical: coupled internal mode at 15.5 Hz. The low frequency of the mode and the coupling prove the suspected limitations of this design

Concept

The module is standing on three leveling bolts; the weight is supported by the two large cross section crossbars.

Advantages

Very rigid, the machine is just standing in place, no static shear stresses, horizontal and vertical adjustment well decoupled

Drawbacks

Manufacturing costs, installation time

Horizontal transverse/Vertical: very well decoupled. Benefit from the standing-like design



WP7 Metrology and stabilisation

Impact of acoustic noise

Experimental set-up

Acoustic pressure and vibration measurements:

- At the free part of the beam
- At the fixed part of the beam

Loudspeaker

Elastic Foam

Passive damping:

Isolation of the loudspeaker from the ground to avoid mechanical vibration

Rubber

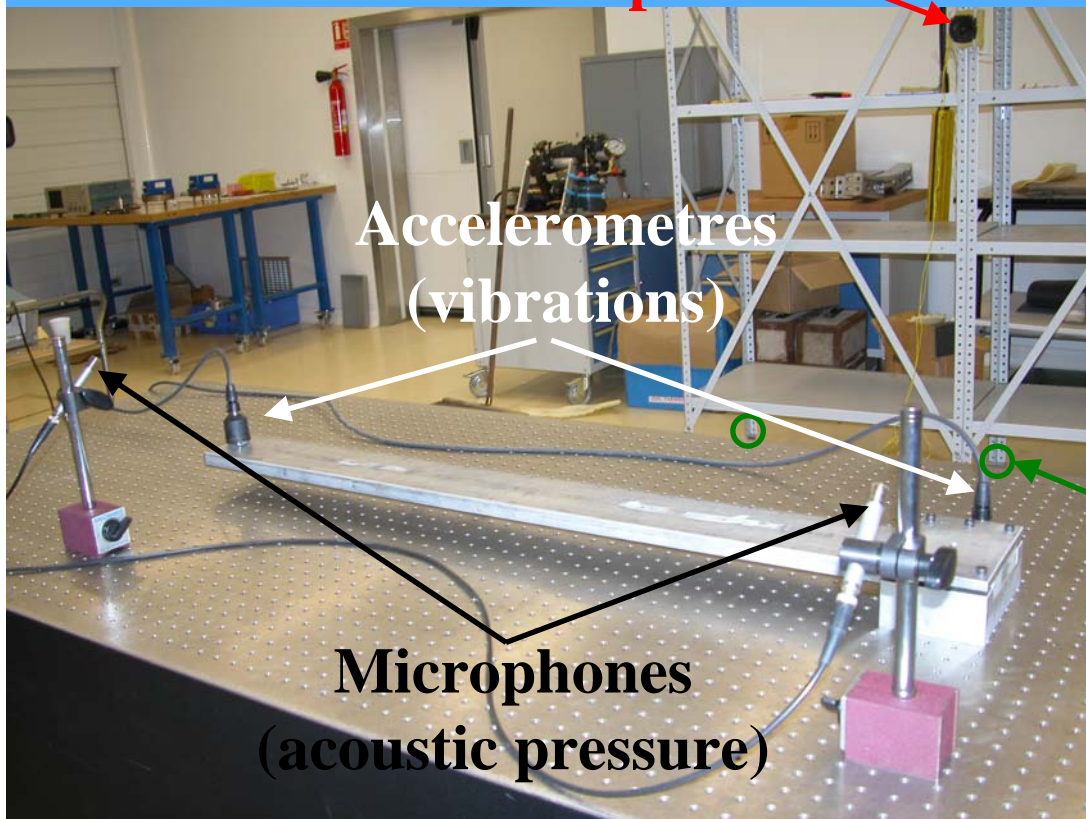

**Accelerometres
(vibrations)**

**Microphones
(acoustic pressure)**

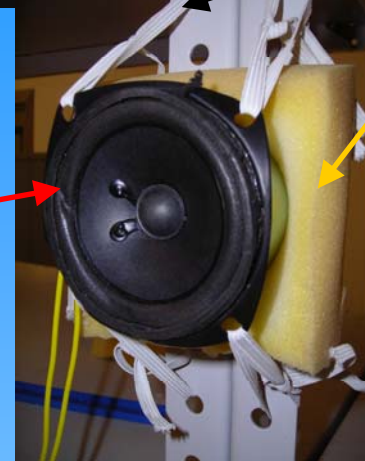



White acoustic noise

Impact of an increase of working room acoustic noise level on the beam eigenfrequency

Accelerometers data

From 800Hz to 1000Hz:

Loudspeaker:

White noise at a
79dB level

No loudspeaker:

Working room noise
at a 49dB level

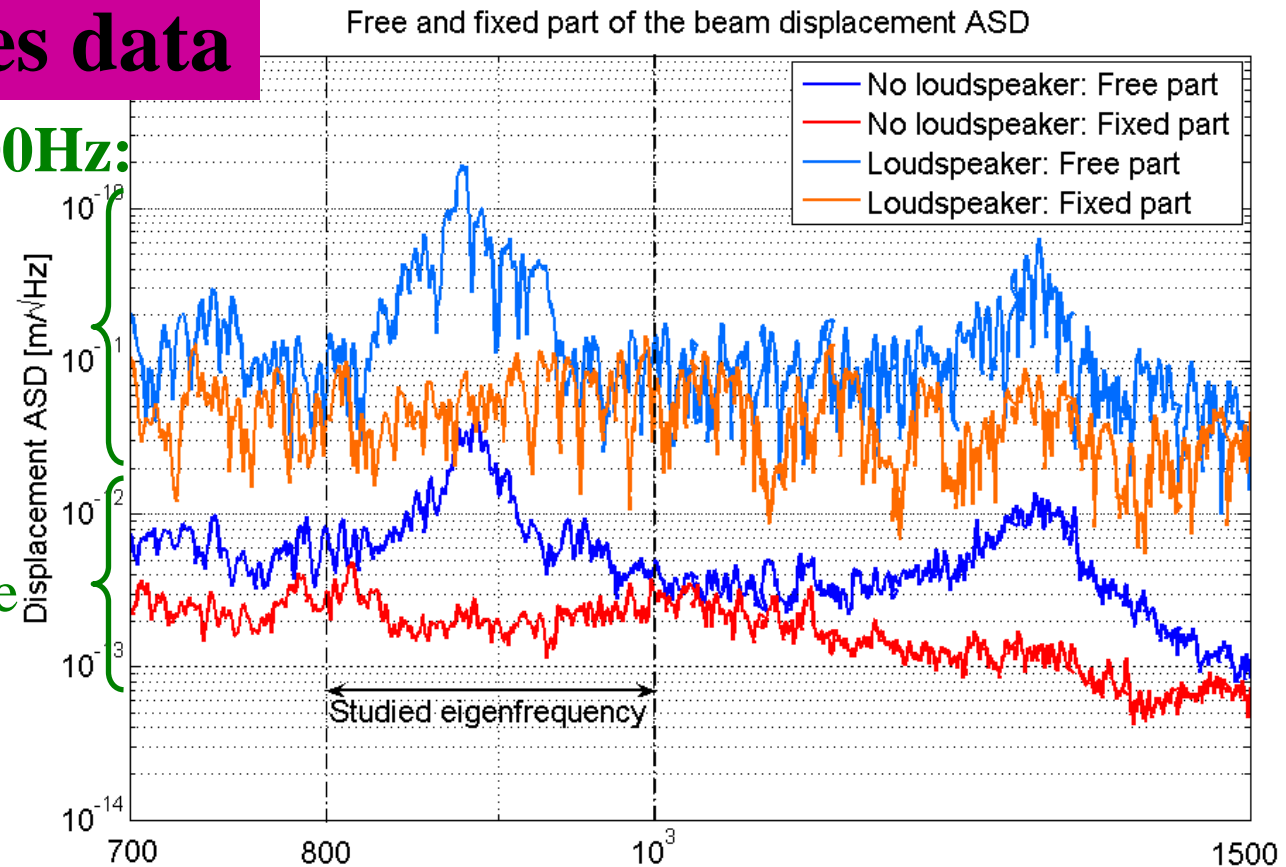

→ Increase of the eigenfrequency amplitude on all its width with white acoustic noise

White acoustic noise

Integrated displacement RMS of the free and fixed part of the beam versus Integrated acoustic pressure RMS

→ **Integrated RMS in [800-1000Hz]**

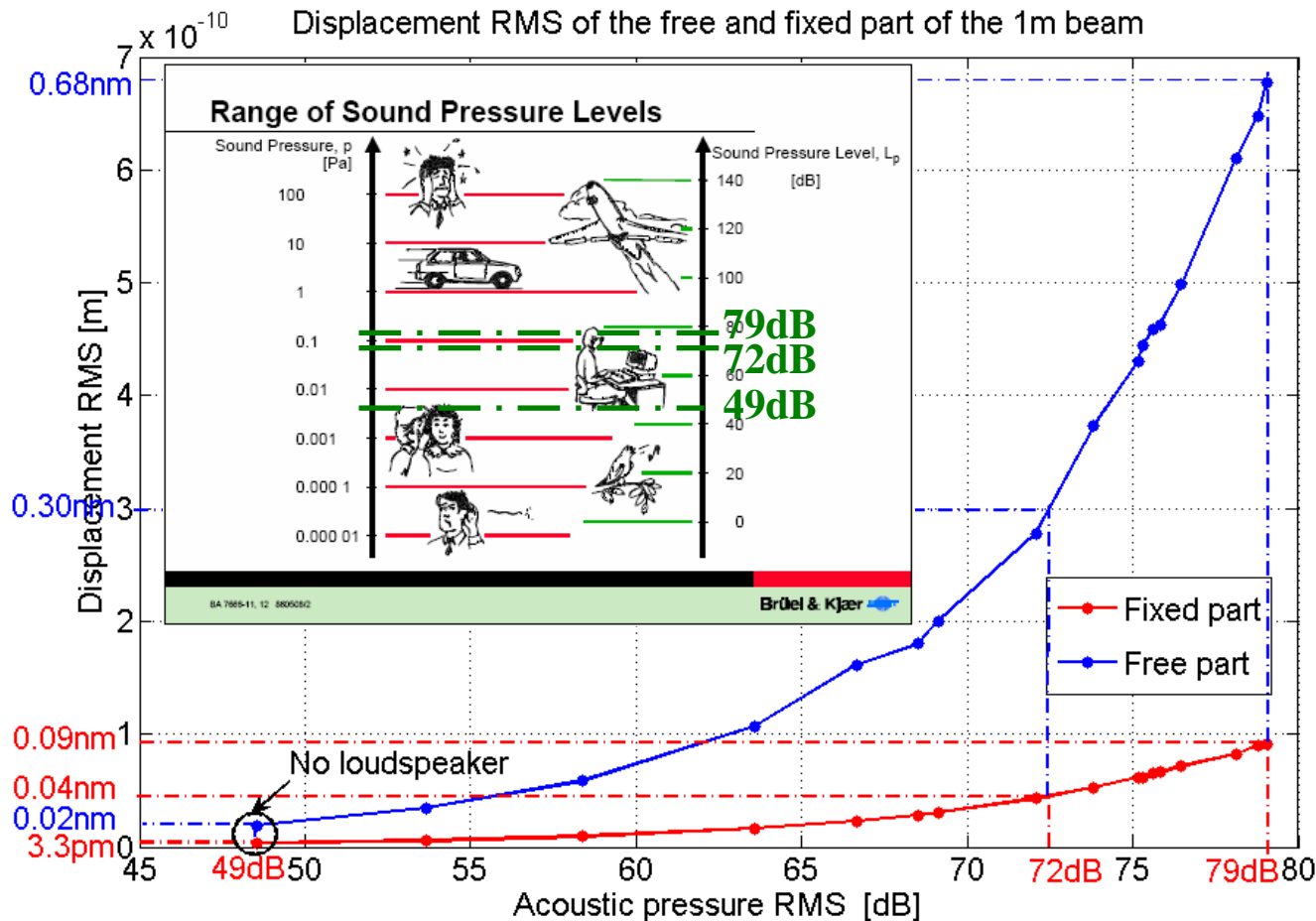

Small increase of acoustic pressure



Non negligible beam displacement in the frequency range [800-1000Hz]

Ground motion : slightly excited

Sine acoustic noise

Integrated displacement RMS of the free and fixed part of the beam versus Integrated acoustic pressure RMS

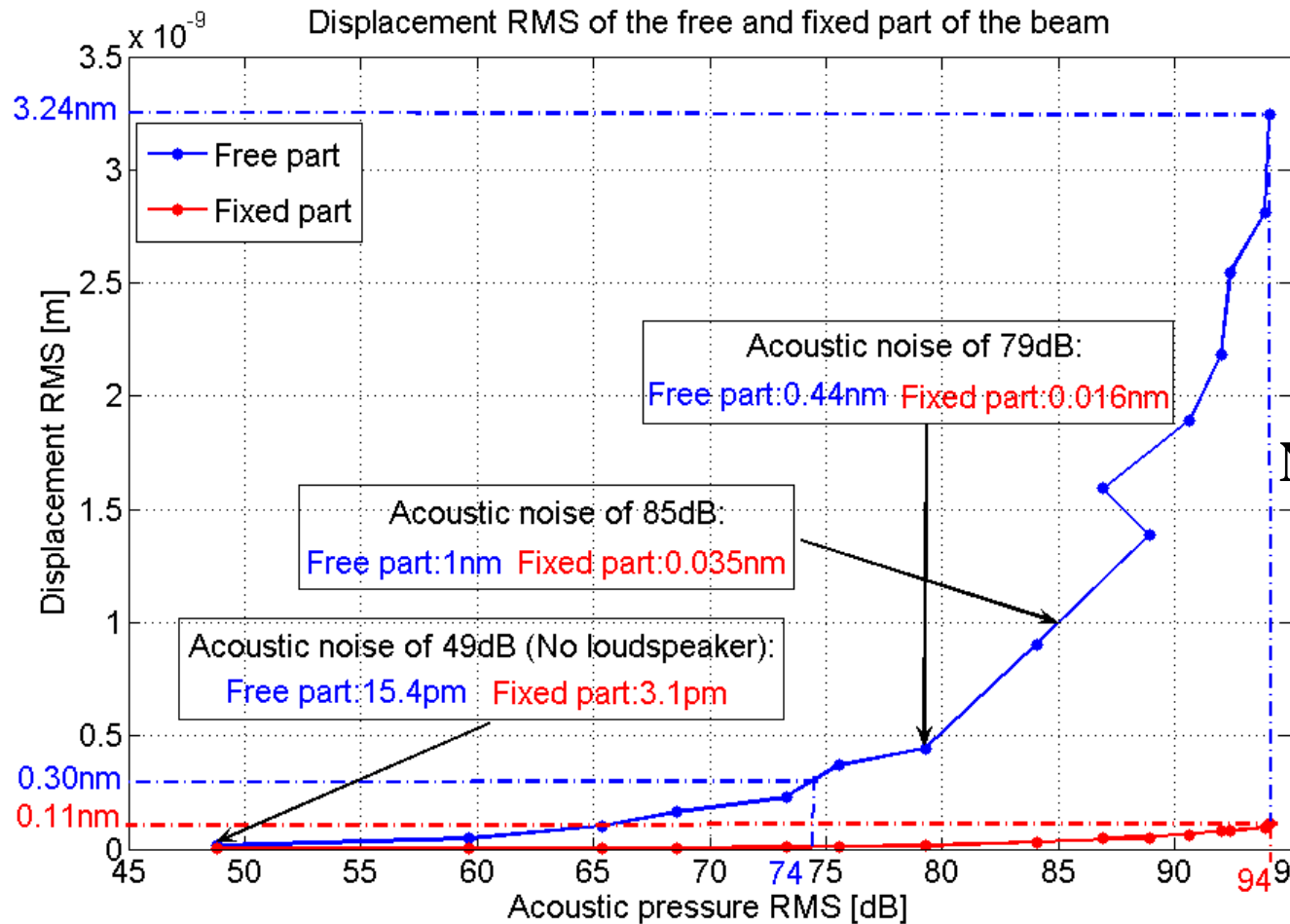

Small increase of acoustic pressure



Non negligible beam displacement in the frequency range [800-1000Hz]

Ground motion not excited

Need to stabilise at high frequency if ILC environment noisy and take into account in predictive models (not just ground motion)



WP7 Metrology and stabilisation

Nanometer scale stabilisation

Results



Rejection of 6 resonances : (without and with rejection) by L. Brunetti

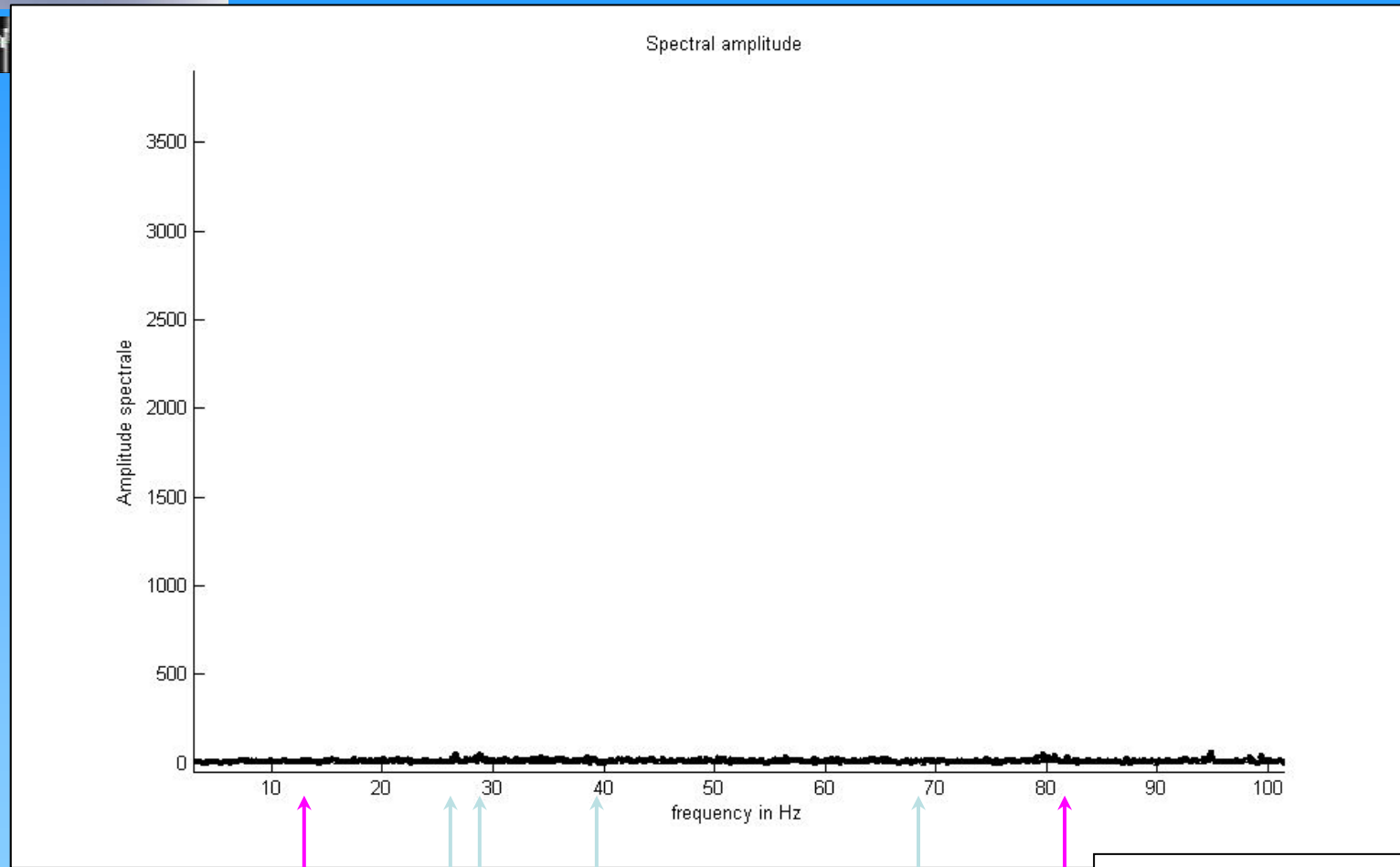

Resonances of : *-beam*
-support



Presentation of the instrumentation

Measurement chain electronic noise

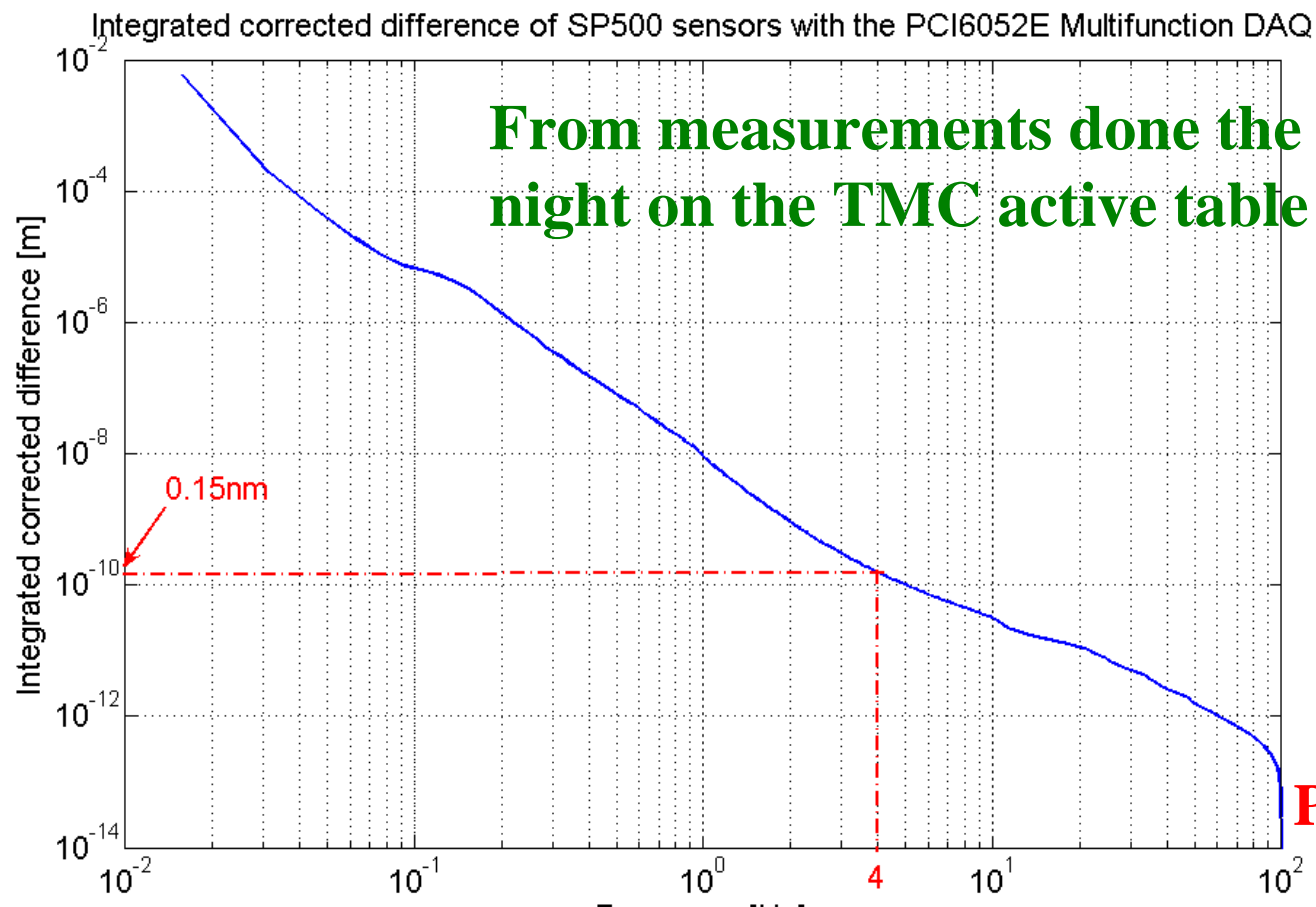

**Non magnetic
SP500B sensor**



PCI6052 DAQ (16 bits)

- ✓ Integrated electronic noise of the total measurement chain above 4Hz:
 - **0.15nm** : enough to do active control at the nanometre scale

First results of stabilisation in the nanometre scale

EUROTeV

Experimental set-up

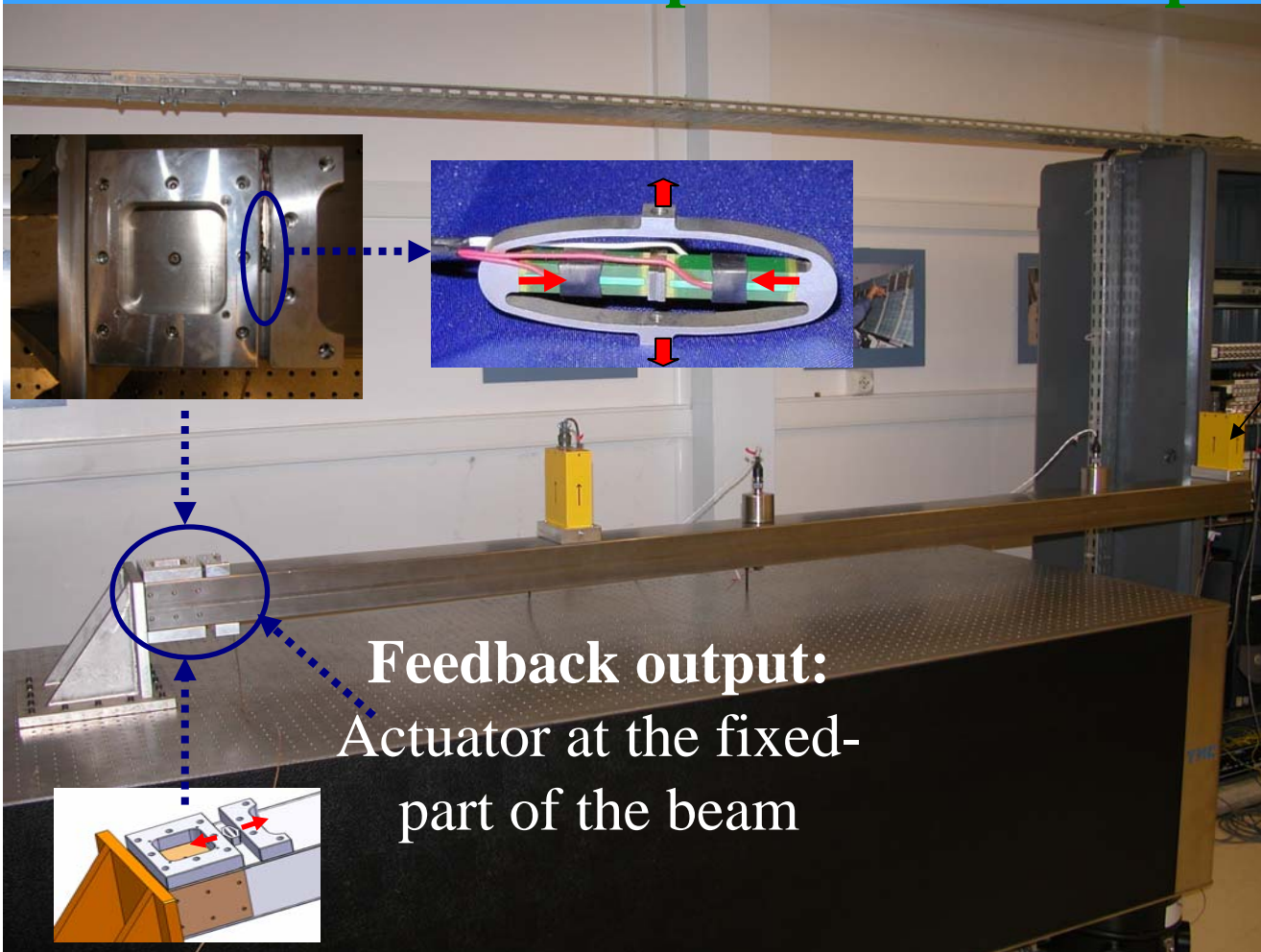

Feedback input:
Sensor at the free-
part of the beam

Feedback output:
Actuator at the fixed-
part of the beam



PCI6052 DAQ:
Sensor acquisition
and actuator control

First results of stabilisation in the nanometre scale

Active rejection of one unknown disturbance frequency

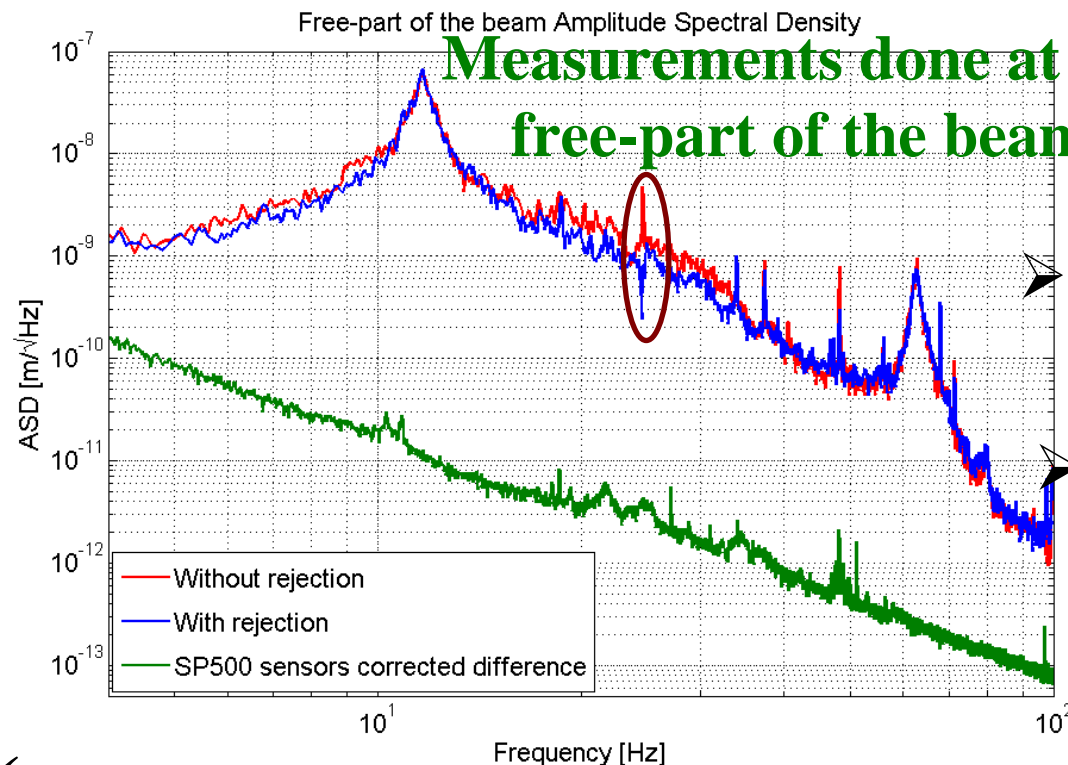

Actuator:

Make the beam move in the nanometre scale

Voltage control well above the output electronic noise

✓ Rejection ok with the initial algorithm (state space) for frequencies which correspond to unknown source disturbances

For eigenfrequencies, necessity to control a larger bandwidth

→ Test of a new algorithm (internal model command), which need also just a punctual knowledge of the system (multiple I/O and position control)

Simulation of whole system still ongoing



WP7 Metrology and stabilisation

METSTB

RTRS



StaFF

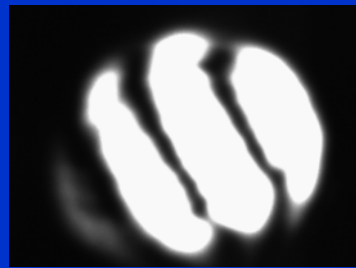

MSTBT



PGMS

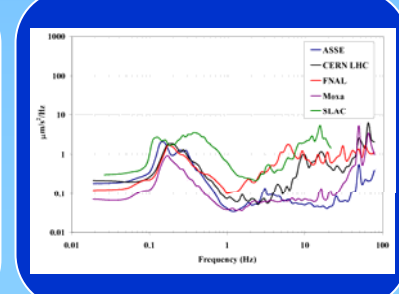



❖ Site Characterization Issues, in collaboration with D. Kruecker (DESY)

Aim: To characterize `cultural noise` at $f > 1$ Hz of the measured sites.

Method: depicting `cultural noise` as deviation from $1/f^4$, or random noise walk behavior. Starting from displacement PSD, $S_x(f)$, we integrate twice to obtain Fourier transform of acceleration, $S_a(f)$, using the relation below:

$$\text{FT} [d/dt x(t)] = -2\pi i f \text{FT} [x(t)]$$

In order to see deviation beyond $1/f^4$ for each site, we plot:

$$\sqrt{S_a(f)} = 4\pi^2 f^2 \sqrt{S_x(f)}$$

Anything above the flat distribution may be considered as `cultural noise`. The base level of the distribution, where it is flat, varies from site to site and gives further insight in the site characterization.

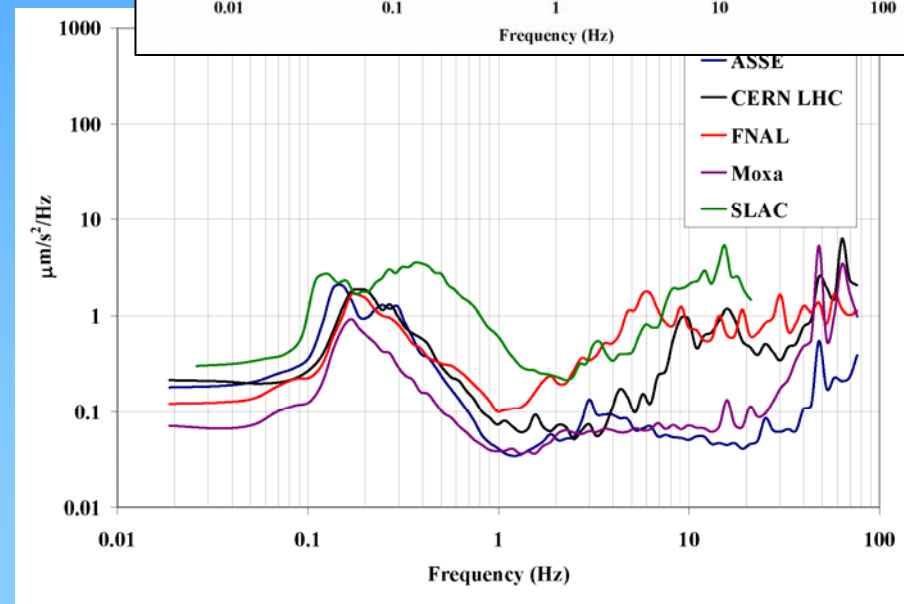
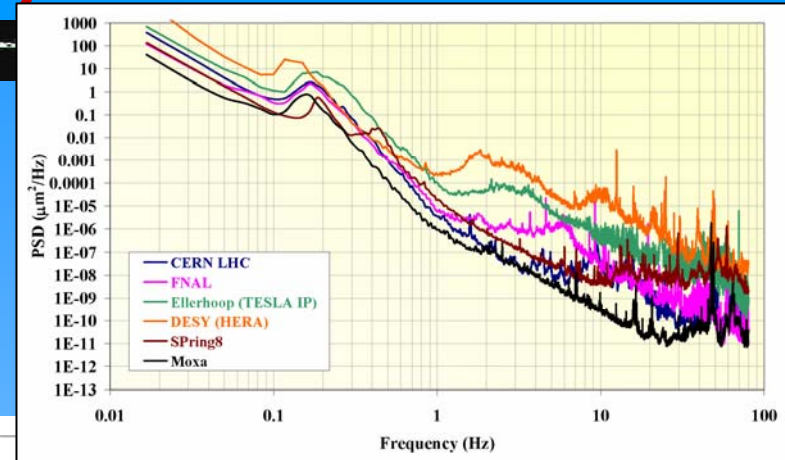

**Acceleration vs. Frequency
(quiet sites)**

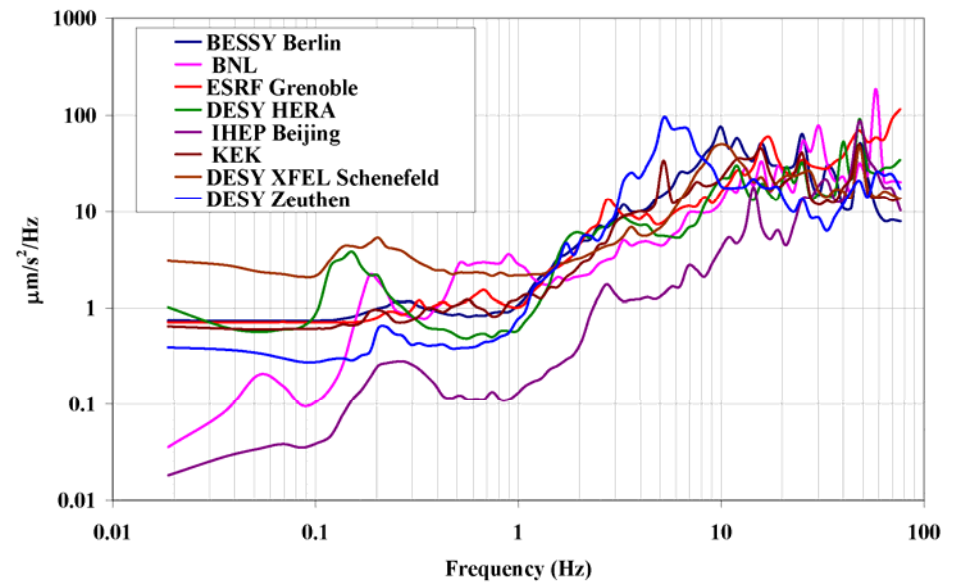
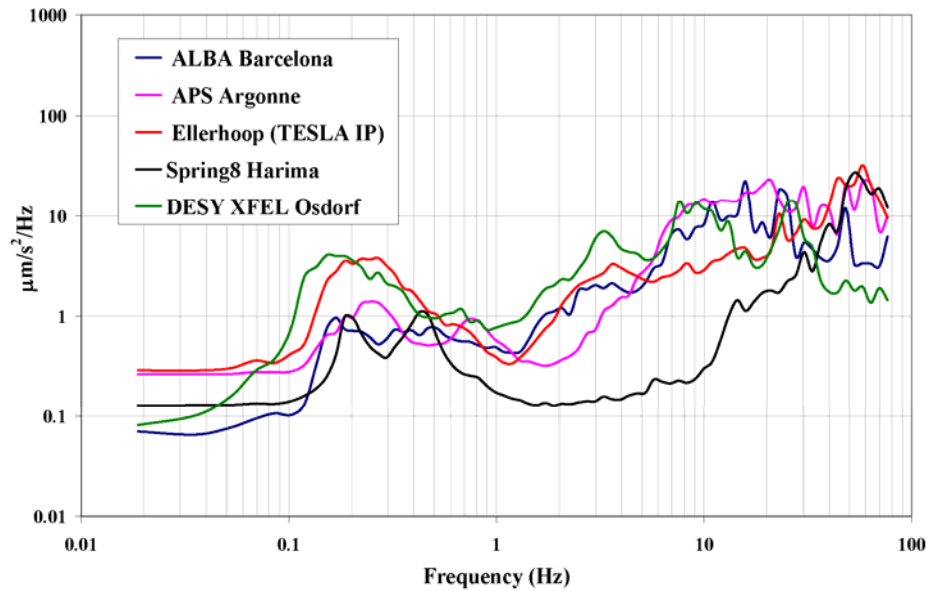
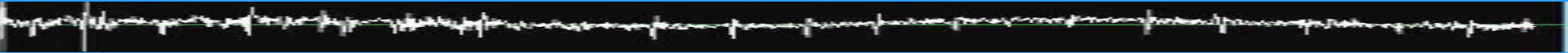

**Acceleration vs. Frequency
(medium sites)**

**Acceleration vs. Frequency
(noisier sites)**



❖ Site Characterization Issues; Coherence/Correlation Measurements of a Site (DESY)

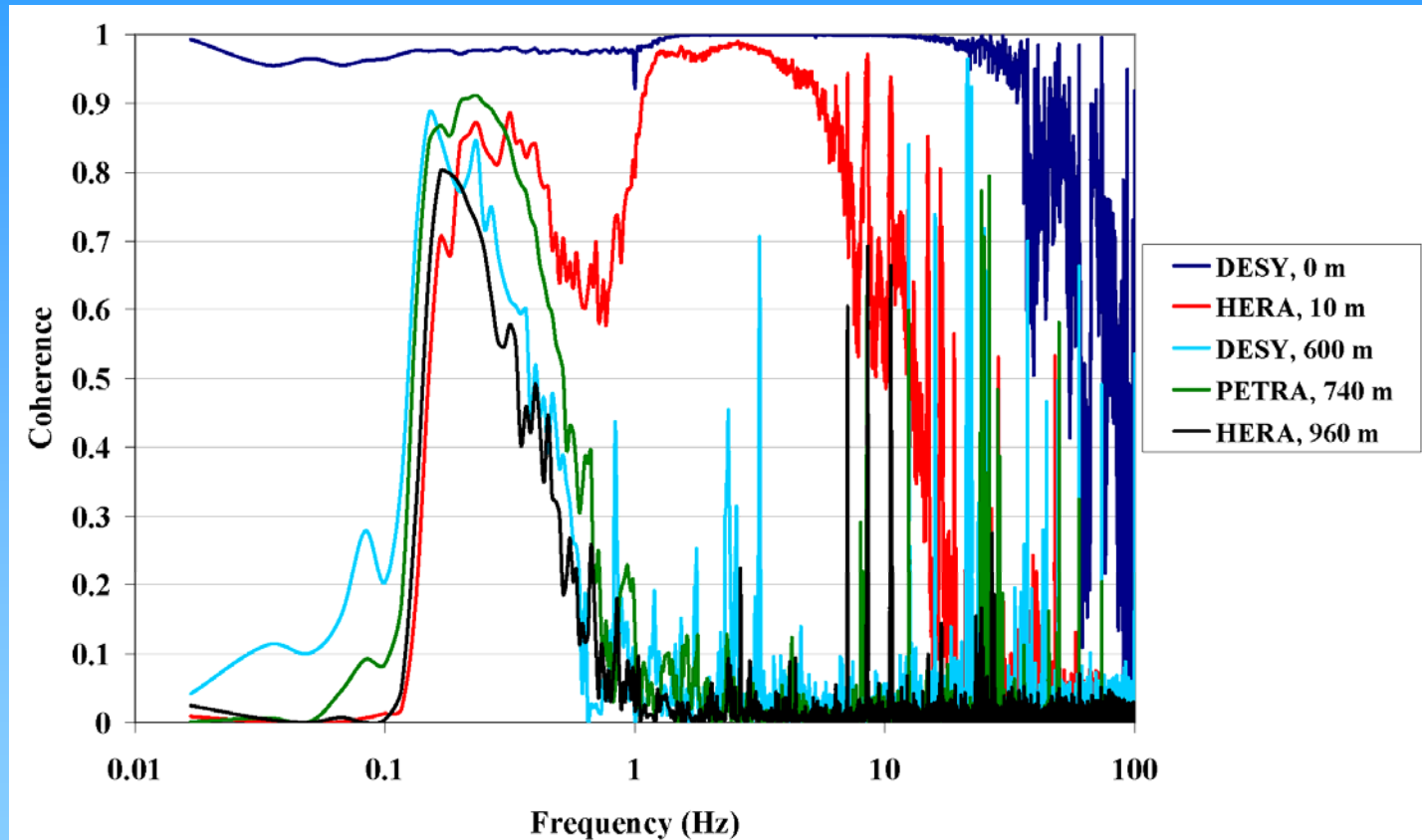

Good coherence signal (> 0.8) at distance (d) = 0 m upto ~13 Hz; at d = PETRA ring circumference, coherence is limited to the microseismic peak.



Conclusion

RTRS: Test the installation in DESY Tunnel ;calibration and determination of residual systematic errors; prepare future XFEL use

StaFF: Installation at ATF2 in November 2007 and confirm 1cm optics system

PGMS: site characterisation mature (data base available via web); coherence length measurements ongoing



Conclusion

- MSTBT:** .Correlation measurements of “warm” cryomodule: rigid !; “cold” is next on the menu
- .Acoustic effects non negligible: take into account in beam dynamics models?
 - .Nanometre scale instrumentation defined for stabilisation; still need work on feedback loop for broad resonance peaks and multi I/O
 - .Measurements on cryomodule supports (standing and hanging) will help in ILC engineering choice => would like to start design of support



Conclusion

General discussion and comments:

- .Results published in Conferences and EUROTeV Notes
- .All groups have hired late...need to go further into 2008
- .Some tests have been delayed and still not done because of accelerator material availability... need some more time
- .Some worries about the future of the work done in Metrology and Stabilisation Workpackage... within the FP7 context
- .maybe will gain more interest as we go from the RDR phase to the EDR phase...