

Machine Detector Interface Issues

Philip Burrows

John Adams Institute

Oxford University

Thanks to: Tom Markiewicz

Outline

- **Reminder and update since last meeting:**
 - push-pull configuration**
 - surface assembly**
- **Technical engineering issues:**
 - FF magnet package**
 - door opening/access**
 - support of 'R20' module**
 - beampipe engineering**
- **Outlook**

Push-pull: SiD assumptions

- **Having two detectors on beamline ‘permanently’, and sharing the luminosity, i.e. two IPs, is clearly the ideal solution for physics**
- **Luminosity delivery to two IPs, with fast switchover between IPs, is not possible**
- **Two detectors in push-pull mode will:**
 - **save cost of one BDS**
 - **increase likelihood of two detectors from start**
 - **provide equal access to luminosity for both detectors**

SiD statement on technical Issues

- **Push-pull can probably be engineered to work**
 - **many technical issues will need to be solved**
- **Full access to offline detector is mandatory**
- **Best accomplished with self-shielding detectors**
 - **self shielding is technically feasible**
- **Mechanisms for moving detector should not reduce acceptance**
- **Need to align 'captured' beamline components independent of overall detector position**

SiD: technical questions

- **Can detector be engineered so magnetic field map remains invariant under detector in/out?**
- **Can tracking chamber alignment be restored without calibration runs (eg. with internal alignment system)?**
- **Can detector remain fully operable in 'out' position?**
 - **cosmic ray data-taking to maintain operability**
- **Can switchover time be made short enough?**

SiD: sociological issues

- **Need well defined procedure for scheduling swaps**
- **Machine luminosity must be shared equitably**
- **Period between swaps should be of order 1 month:**
 - neither detector can gain significant lumi advantage in 1 period
- **Switch-over time \ll running period**

Concept which does not rely on self-shielding detector

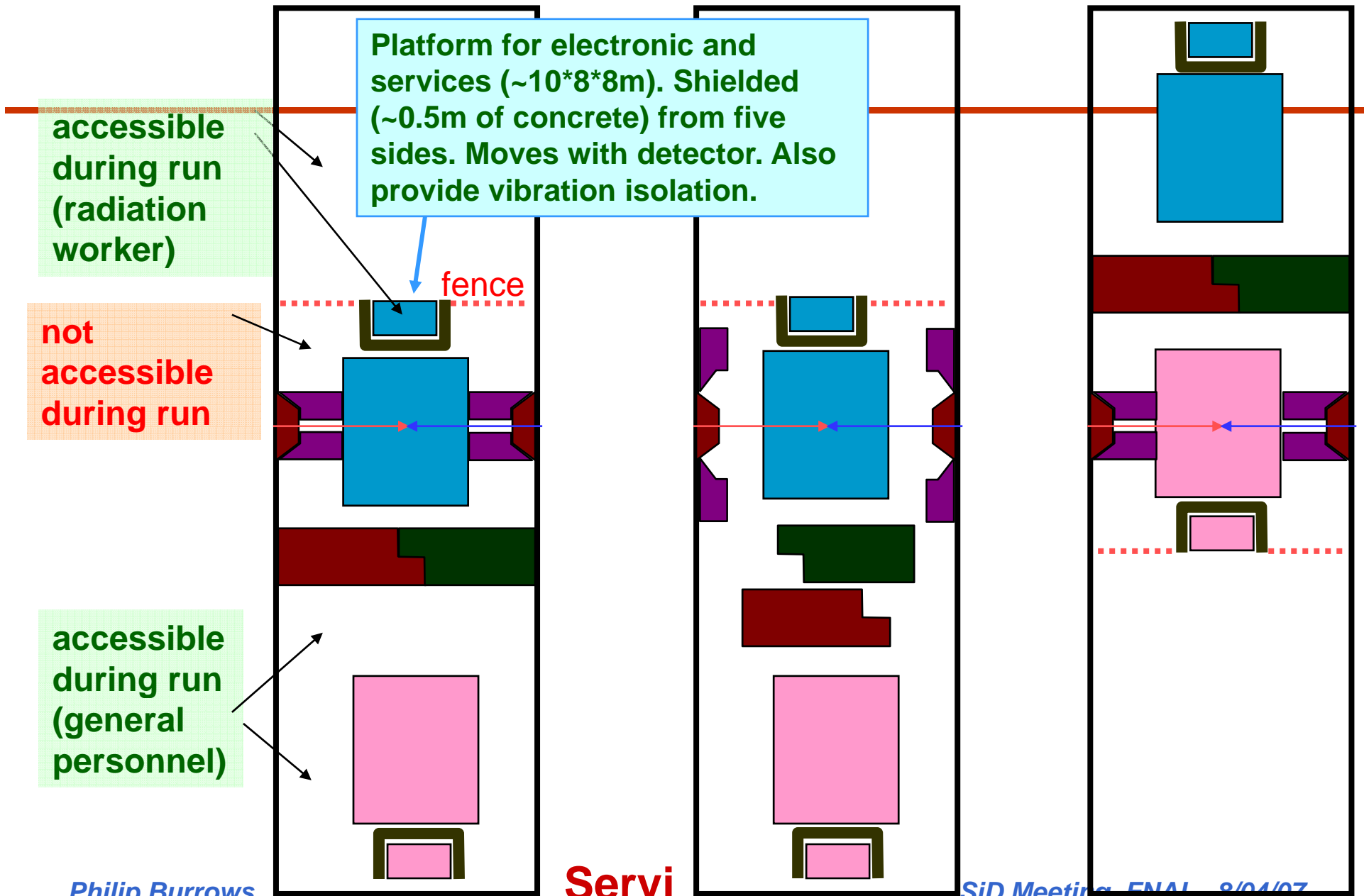

Philip Burrows

Seryi

SiD Meeting, FNAL 8/04/07

On-surface (a la CMS) detector assembly

According to tentative CF&S schedule, detector hall would not be ready for detector assembly until 4y11m after project start

If so, cannot fit into the goal of “7 years until first beam” and “8 years until physics run”

Surface assembly allows earlier start by 2-2.5 years and meets this goal

The collider hall size is also smaller in this case

- surface building needed, but potential savings still substantial

Assumptions were made on sizes of underground hall + surface building, shafts, cranes above and below ground ... **will be revisited**

- **needs serious engineering study of assembly, installation, access, safety, services, cabling ...**

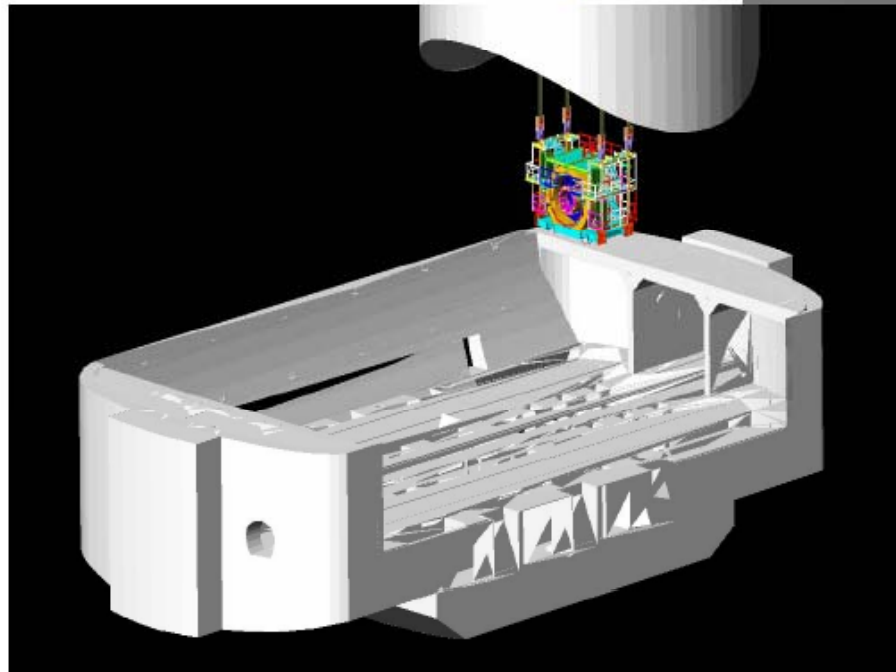
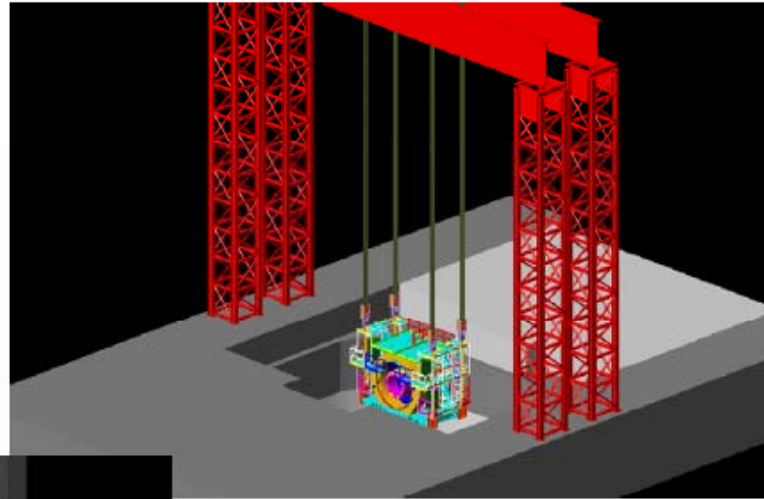
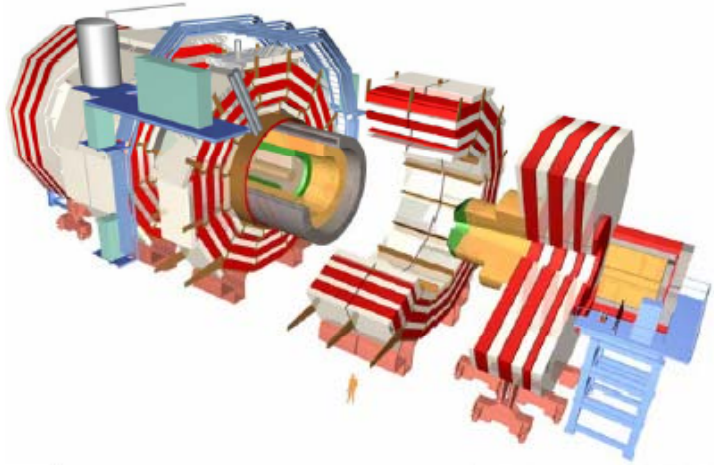

CMS assembly approach:

- Assembled on the surface in parallel with underground work
- Allows pre-commissioning before lowering
- Lowering using dedicated heavy lifting equipment:
15 loads, 300-> 2000t
- Potential for big time saving
- Reduce size of underground hall required

D. Angal-Kalinin

Air-pads at CMS

Single air-pad capacity ~385tons (for the first end-cap disk which weighs 1400 tons). Each of air-pads equipped with hydraulic jack for fine adjustment in height, also allowing exchange of air pad if needed. Lift is ~8mm for 385t units. Cracks in the floor should be avoided, to prevent damage of the floor by compressed air (up to 50bars) – use steel plates (4cm thick). [Alain Herve, et al.]



Photo from the talk by Y.Sugimoto,
<http://ilcphys.kek.jp/meeting/lcdds/archives/2006-10-03/>

SiD surface assembly considerations (Marty)

Solid Edge Model

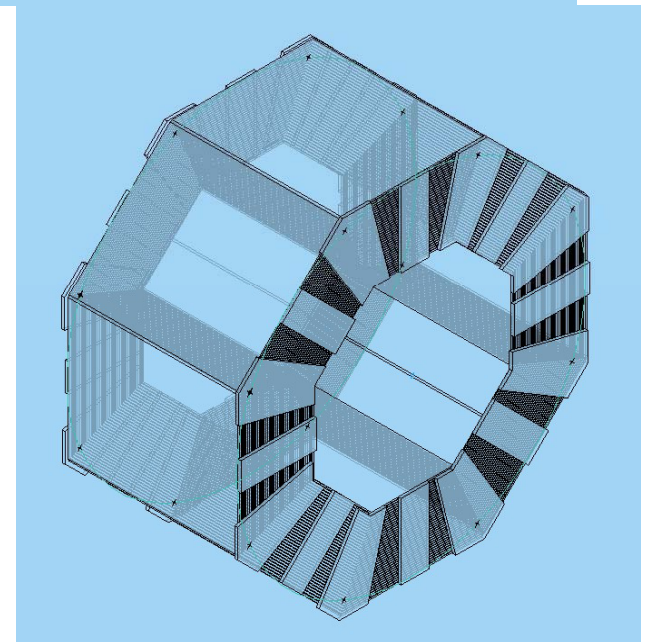
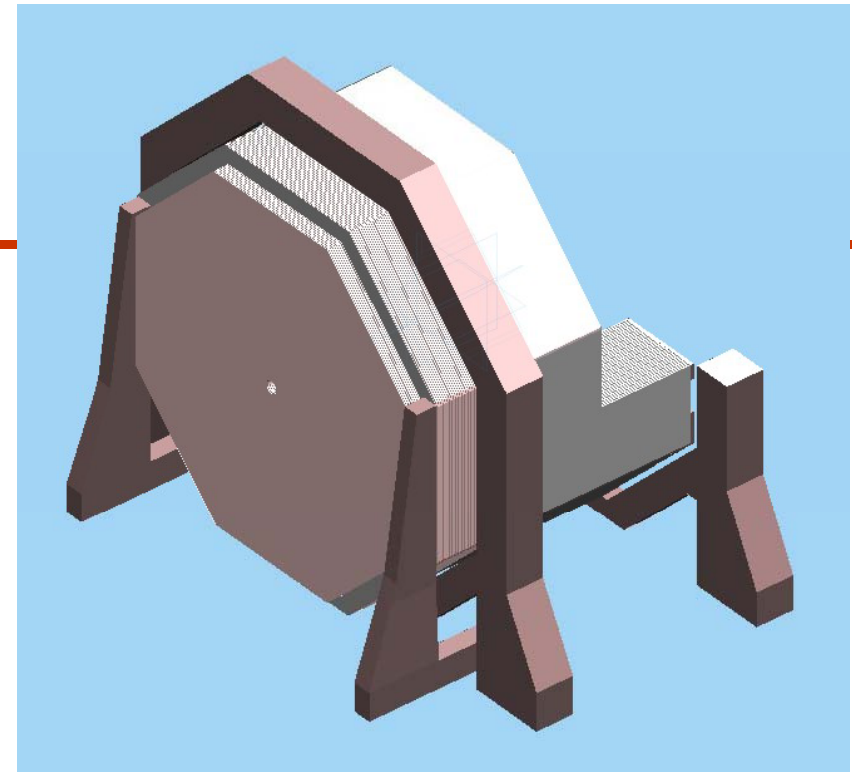
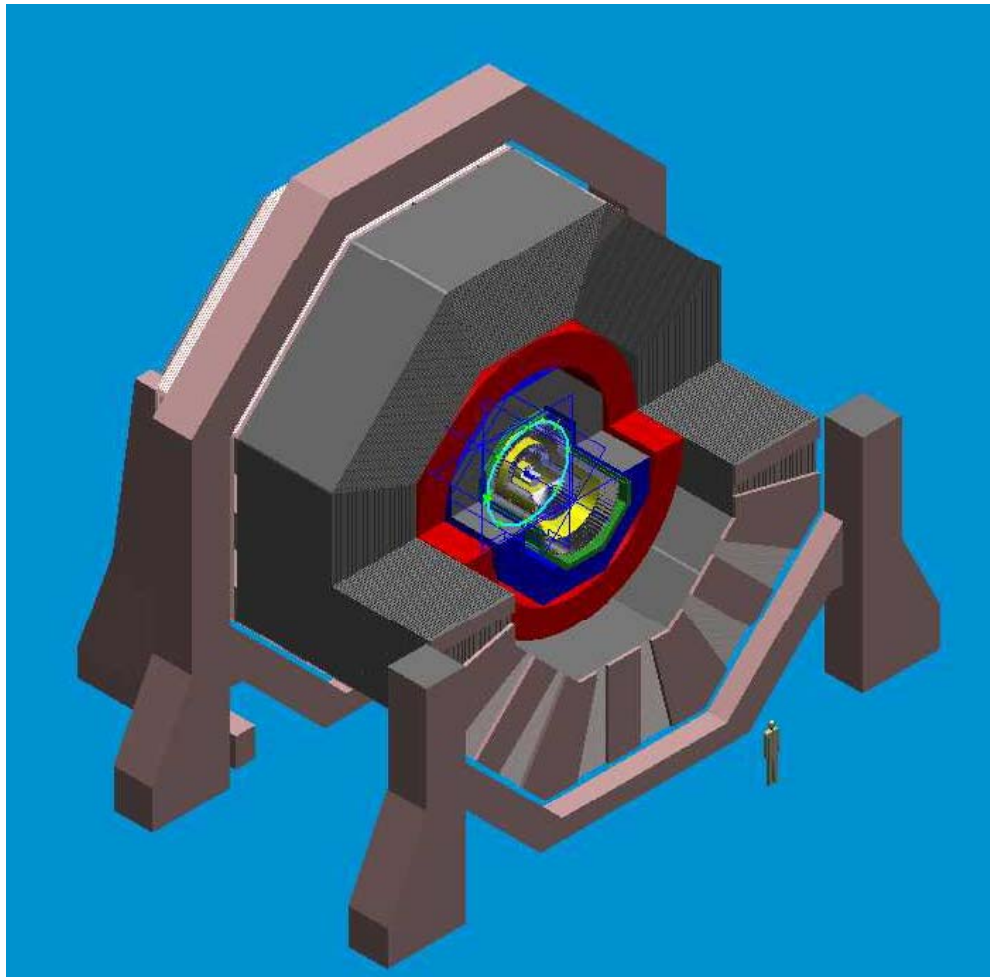

Sequence of Operations

Detector subassembly construction & surface tests

- Octants of muon chamber instrumented barrel yoke, barrel Hcal, barrel Ecal
- Four sub-modules of EC return flux instrumented with muon chambers, donut Hcal, Ecal
- Tracker, vertex and FCAL packages

Surface Magnet test

- Assemble barrel support and the bottom 5/8 flux return octants
- Drop in coil & cover with remaining 3/8 octants
- Assemble two door legs and 4 360° (180 °?) plates of flux return
- Test magnet and disassemble

Lower detector chunks

- Reassemble lower barrel iron with supports below ground
- Load barrel HCAL and ECAL modules into coil cryostat via threaded beam
- Lower loaded coil package and capture with upper barrel yoke segments
- Depending on crane capacity
 - Lower fully assembled door
 - Lower door pieces, the last plate with the Endcap Ecal & Hcal, and reassemble

Tracker, VXD and FCAL installed below ground at end

‘Surface assembly seems ok, but will require careful planning’

Surface assembly parameters (Marty)

M-Tons	Stainless HCAL Radiator		Tungsten HCAL Radiator	
	Barrel	Endcap x2	Barrel	Endcap x2
EM Cal	59	19	59	19
HCAL	354	33	367	46
Coil	160		116	
Iron	2966/8= 374.5	2130/4= 532.5	1785/8= 223.125	1284
Support x 2 (each ~5%Fe)	150	110	90	65
Total to Lower	Loaded Coil=573	Assembled Door=2402	Loaded Coil=542	Assembled Door=1479
Shaft Diameter(m)	8.3m	10.4+2.0m		

Surface assembly parameters (Marty)

M-Tons	Stainless HCAL Radiator		Tungsten HCAL Radiator	
	Barrel	Endcap x2	Barrel	Endcap x2
EM Cal	59	19	59	19
HCAL	354	33	367	46
Coil	160		116	
Iron	2966/8= 374.5	2130/4= 532.5	1785/8= 223.125	1284
Support x 2 (each ~5%Fe)	150	110	90	65
Total to Lower	Loaded Coil=573	Assembled Door=2402	Loaded Coil=542	Assembled Door=1479
Shaft Diameter(m)	8.3m	10.4+2.0m		

Surface assembly parameters (Marty)

M-Tons	Stainless HCAL Radiator		Tungsten HCAL Radiator	
	Barrel	Endcap x2	Barrel	Endcap x2
EM Cal	59	19	59	19
HCAL	354	33	367	46
Coil	160		116	
Iron	2966/8= 374.5	2130/4= 532.5	1785/8= 223.125	1284
Support x 2 (each ~5%Fe)	150	110	90	65
Total to Lower	Loaded Coil=573	Assembled Door=2402	Loaded Coil=542	Assembled Door=1479
Shaft Diameter(m)	8.3m	10.4+2.0m		

Surface assembly parameters (Marty)

M-Tons	Stainless HCAL Radiator		Tungsten HCAL Radiator	
	Barrel	Endcap x2	Barrel	Endcap x2
EM Cal	59	19	59	19
HCAL	354	33	367	46
Coil	160		116	
Iron	2966/8= 374.5	2130/4= 532.5	1785/8= 223.125	1284
Support x 2 (each ~5%Fe)	150	110	90	65
Total to Lower	Loaded Coil=573	Assembled Door=2402	Loaded Coil=542	Assembled Door=1479
Shaft Diameter(m)	8.3m	10.4+2.0m		

Surface assembly parameters (Marty)

M-Tons	Stainless HCAL Radiator		Tungsten HCAL Radiator	
	Barrel	Endcap x2	Barrel	Endcap x2
EM Cal	59	19	59	19
HCAL	354	33	367	46
Coil	160		116	
Iron	2966/8= 374.5	2130/4= 532.5	1785/8= 223.125	1284
Support x 2 (each ~5%Fe)	150	110	90	65
Total to Lower	Loaded Coil=573	Assembled Door=2402	Loaded Coil=542	Assembled Door=1479
Shaft Diameter(m)	8.3m	10.4+2.0m		

Surface assembly parameters (Marty)

M-Tons	Stainless HCAL Radiator		Tungsten HCAL Radiator	
	Barrel	Endcap x2	Barrel	Endcap x2
EM Cal	59	19	59	19
HCAL	354	33	367	46
Coil	160		116	
Iron	2966/8= 374.5	2130/4= 532.5	1785/8= 223.125	1284
Support x 2 (each ~5%Fe)	150	110	90	65
Total to Lower	Loaded Coil=573	Assembled Door=2402	Loaded Coil=542	Assembled Door=1479
Shaft Diameter(m)	8.3m	10.4+2.0m		

BDS IR-related CF&S master table

Item	SiD	LDC	GLD	CM S	Vancouver WBS (for each hall)	For Valencia Config.A (for single common hall)	Config.B (for single common hall)	Determined by
<i>Parameters that define the underground hall volume</i>								
IR Hall Area(m) (W x L)	28x48 (18x48)	30x45	25x55	26.5 x53 max	32x72	25x110	25x110	Detector concepts
Beam height above IR hall floor (m)	7.5	8	8.6	8.79 m	8.6	8.6	8.6	Concepts, BDS
IR Hall Crane Maximum Hook Height Needed(m)	5m above top of detector	19	20.5	18m	30	20.5	20.5	Detector concepts
Largest Item to Lift in IR Hall (weight and dimensions)	100t PACMAN shielding	55t, 3m x 3m x 1.5m, E/HCAL end cap quadrant	Pieces of yoke 400t	20t insta l tool 7x4 m		400t	100t	Detector concepts
IR Hall Crane	100t/10t aux.	80t (2x40t)	400t	20t	20t x 2	400t +2*20t	100t +2*20t	Detector concepts
IR Hall Crane Clearance Above Hook to the roof (m)	TBD by engineering staff	6	TBD	5 m	5	14.5 (includes arch)	12.5 (includes arch)	CF&S group
Resulted total size of the collider hall (W x L x H)	28x48x30 (18x48x30)	30x45x25	25x55x 35	53x2 6x25	32x72x35	25x110x35	25x110x33	Concepts & CF&S group
<i>Parameters that define dimensions of the IR hall shaft and the shaft crane</i>								
Largest Item; Heaviest item to Lower Through IR Shaft (weight and dimensions) <i>Philip Burrows</i>	Coil package 600t – size End-dors 2000t each/halves	Central Part ~2000t; 12-14m x 7m;	270t coil 9*9m Iron- 15m	1950 t		9*9m 400t	4*16m 2000t	Detector concepts <i>04/07</i>

SiD inner IR layout 2006-05-07

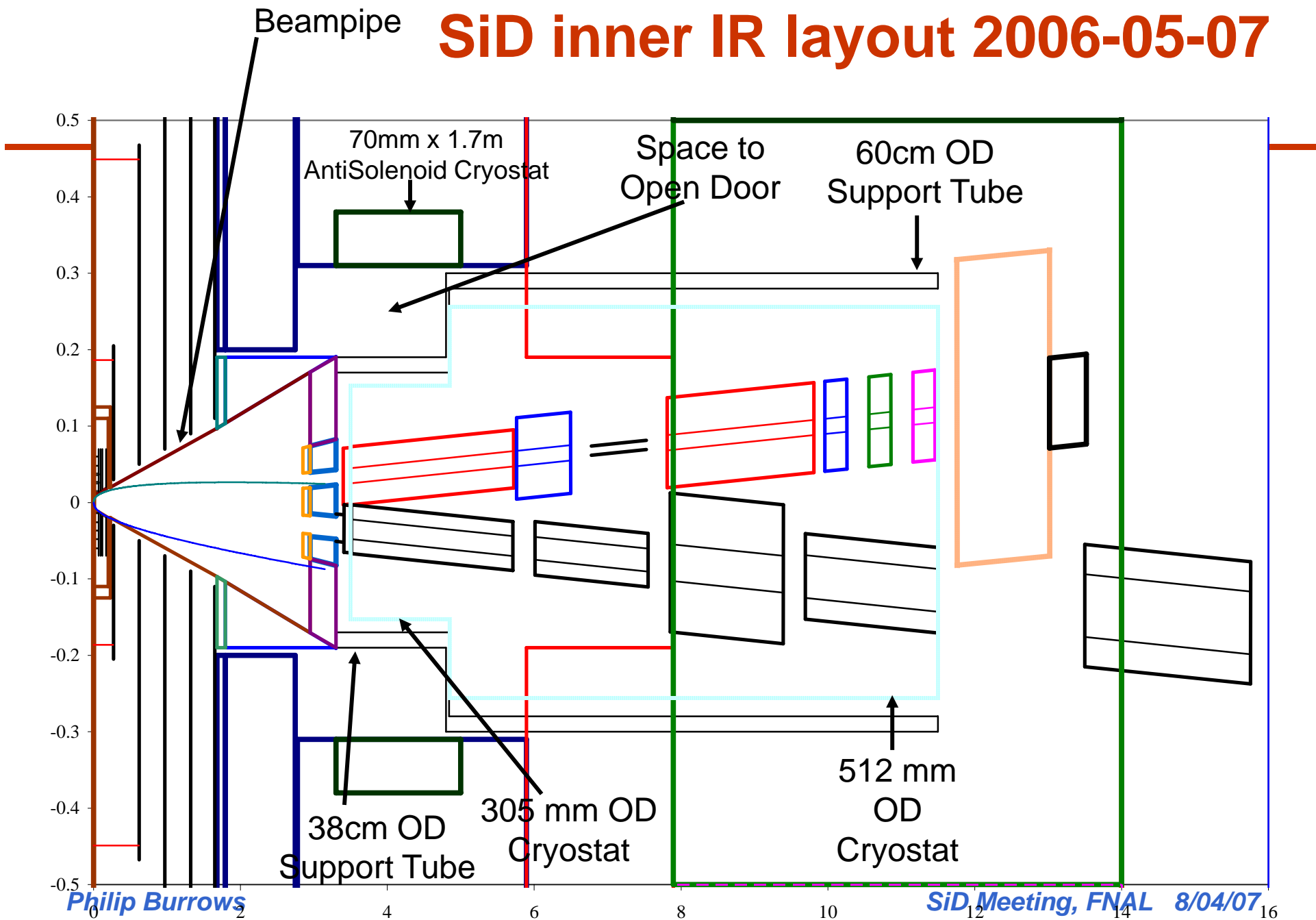

20 Feb 2007 BDS mtg: Brett Parker

Concept for Force Neutral Anti-Solenoid

First approximate with air coils.

With 2:1 turn ratio found that $R_3 = \sqrt{2} R_2$ for forces to cancel... but can still have non-zero field on axis.

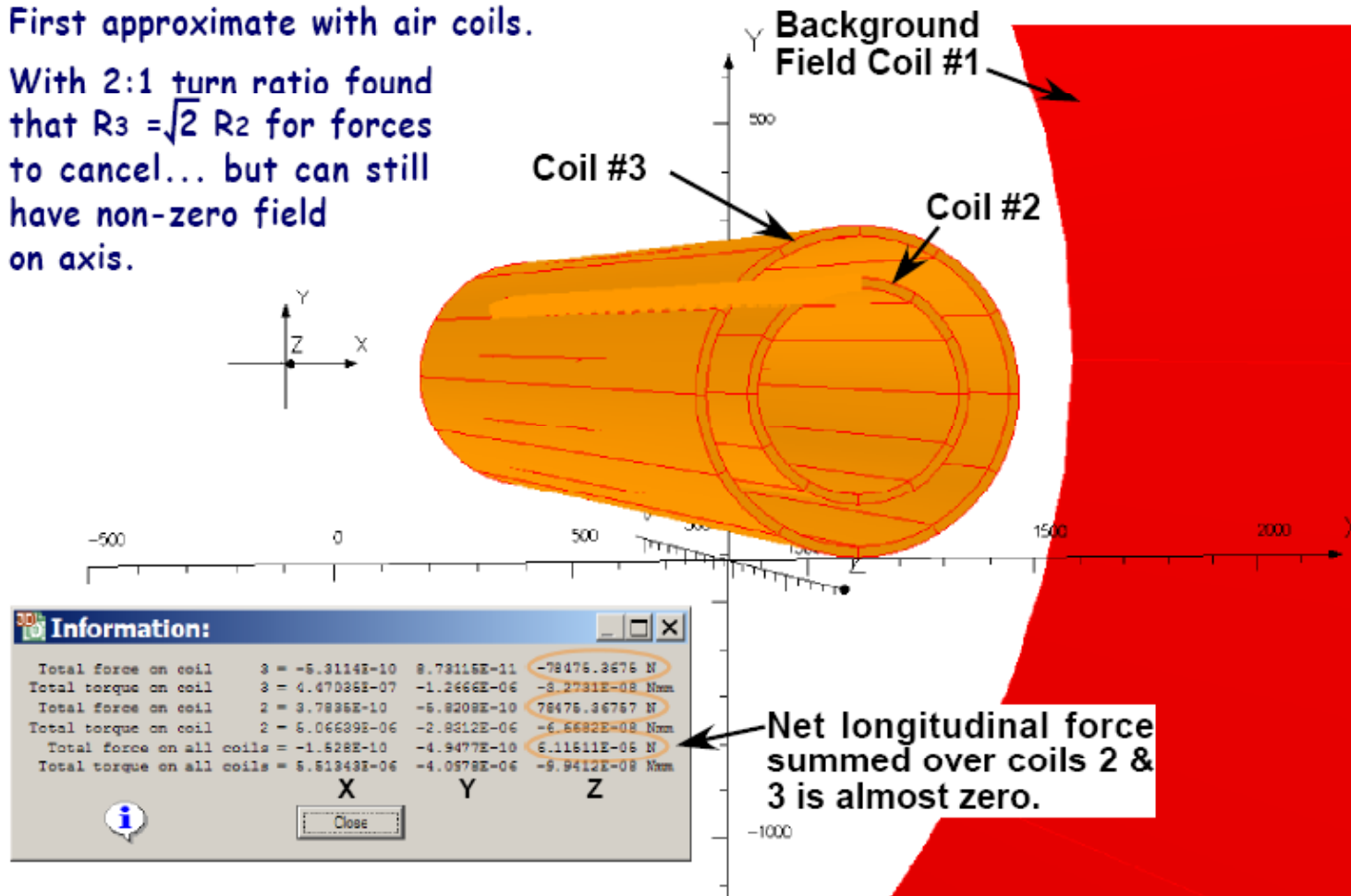

QD0 + QDEX1A + Anti-Solenoid in Cryostat

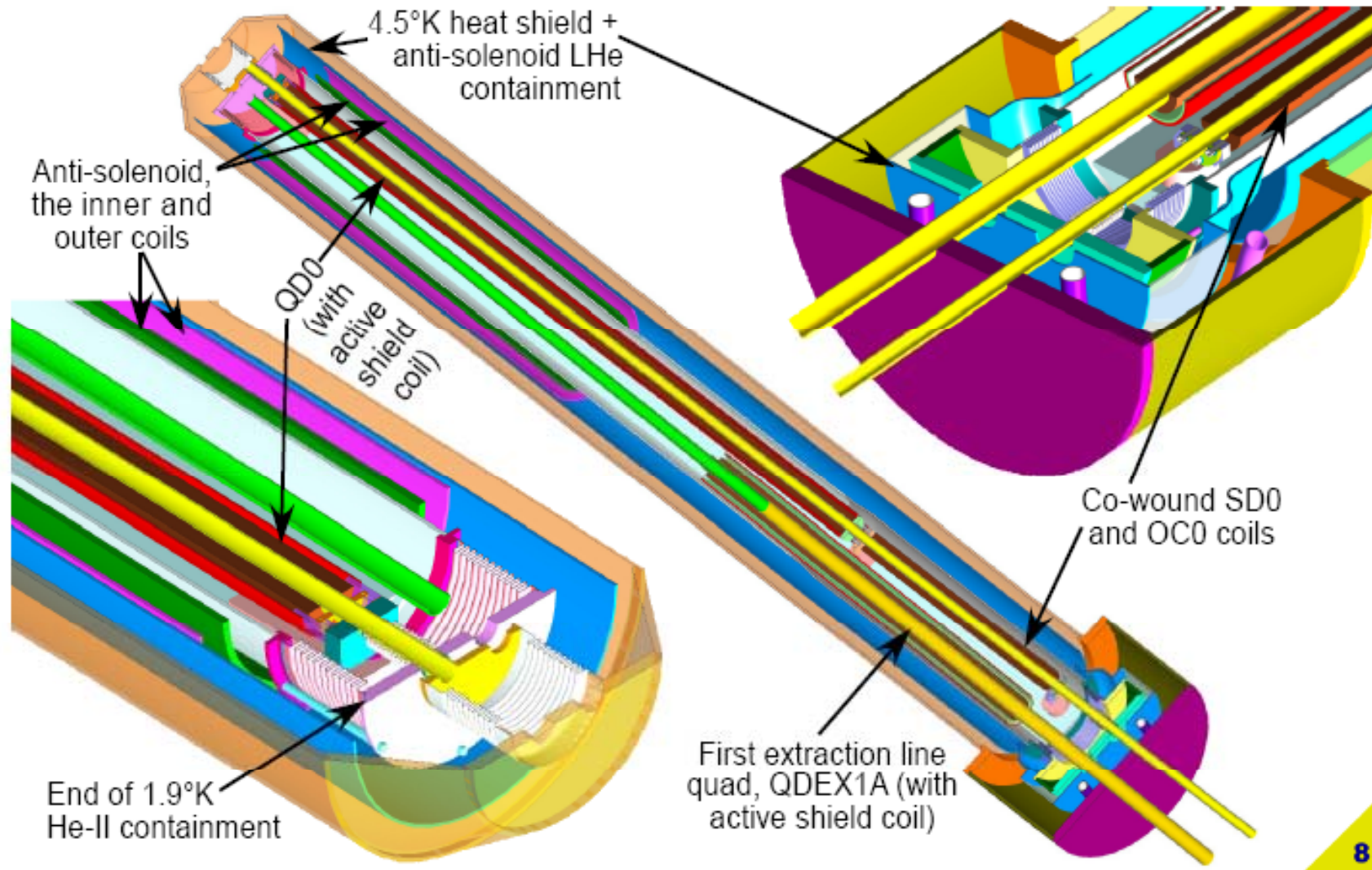

Plan View - Details

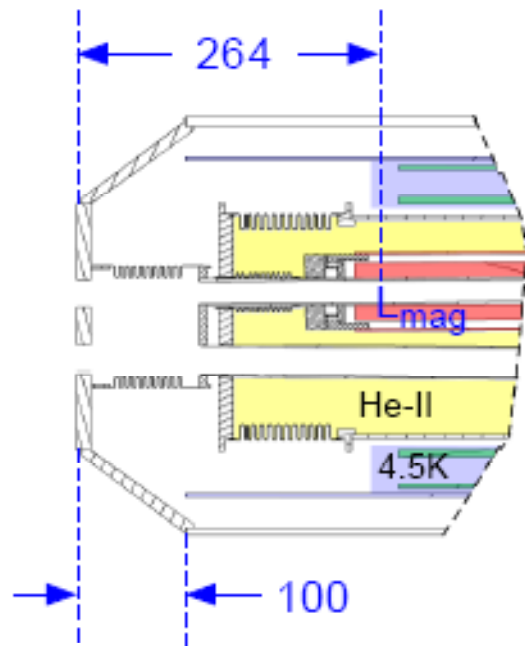

QDO cryostat with a force neutral anti-solenoid compatible with L^* of up to 4.5 m.
Plan views are drawn at beams' common midplane; dimensions are as indicated in millimeters.

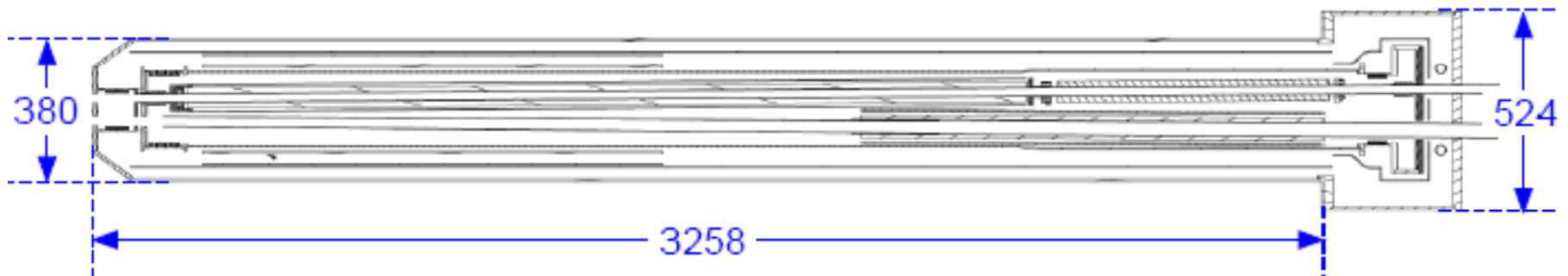
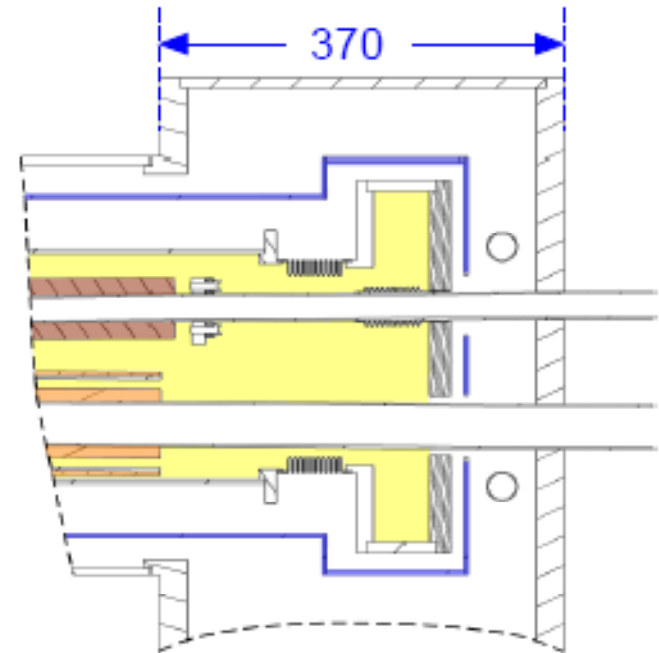

Elevation View - Details

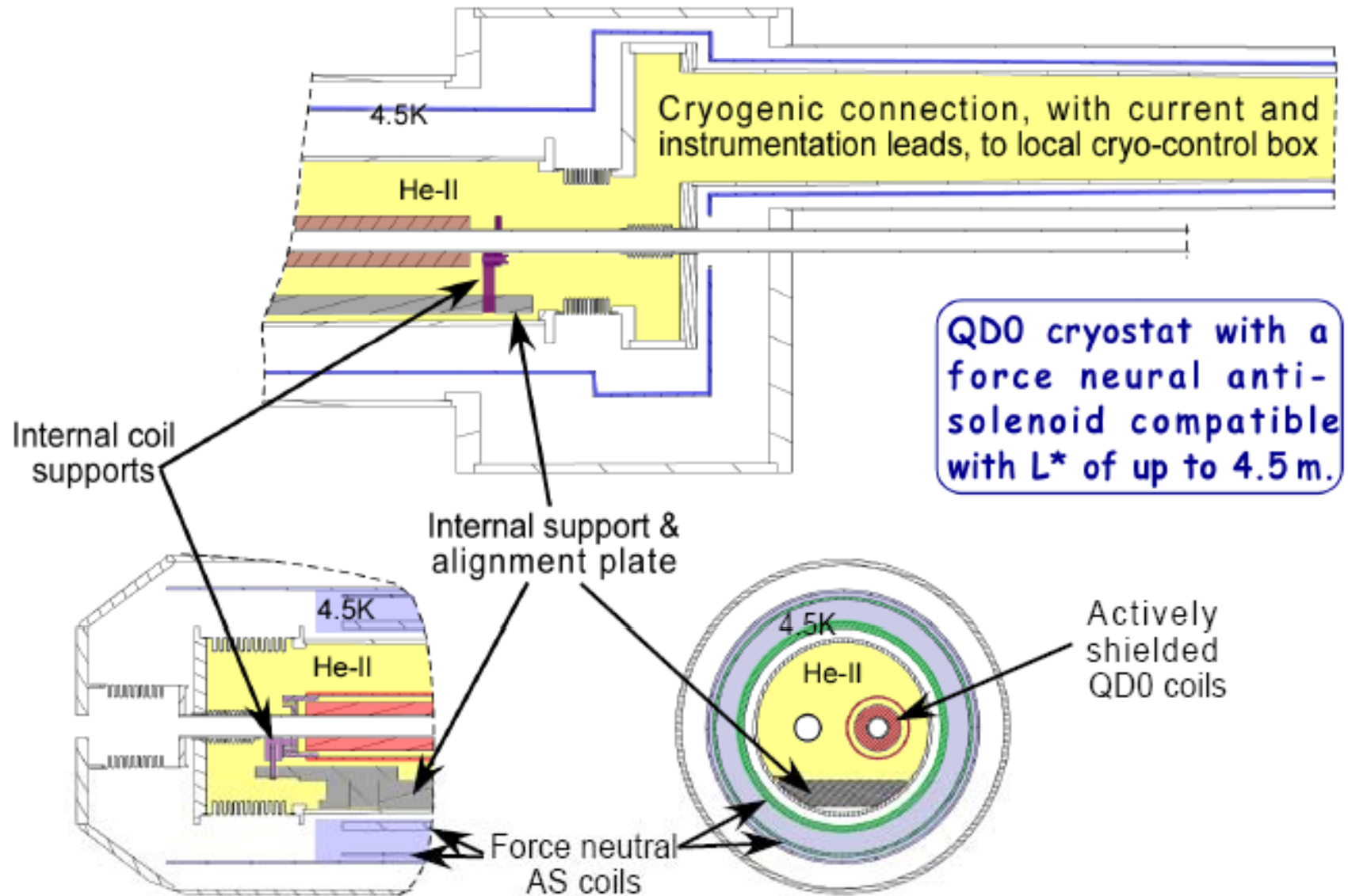

QD0 Cryostat in SiD @ $L^*=3.664\text{m}$

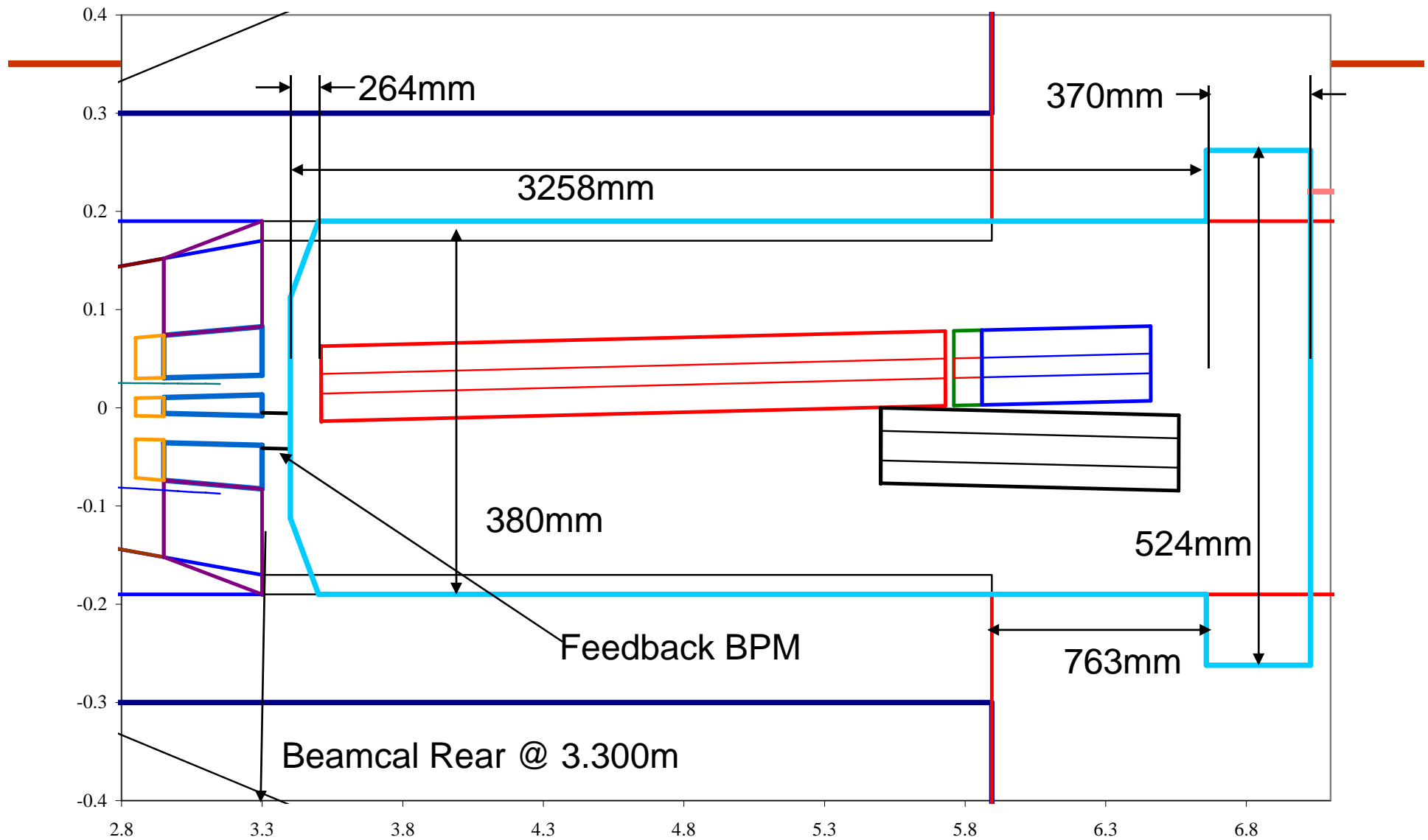

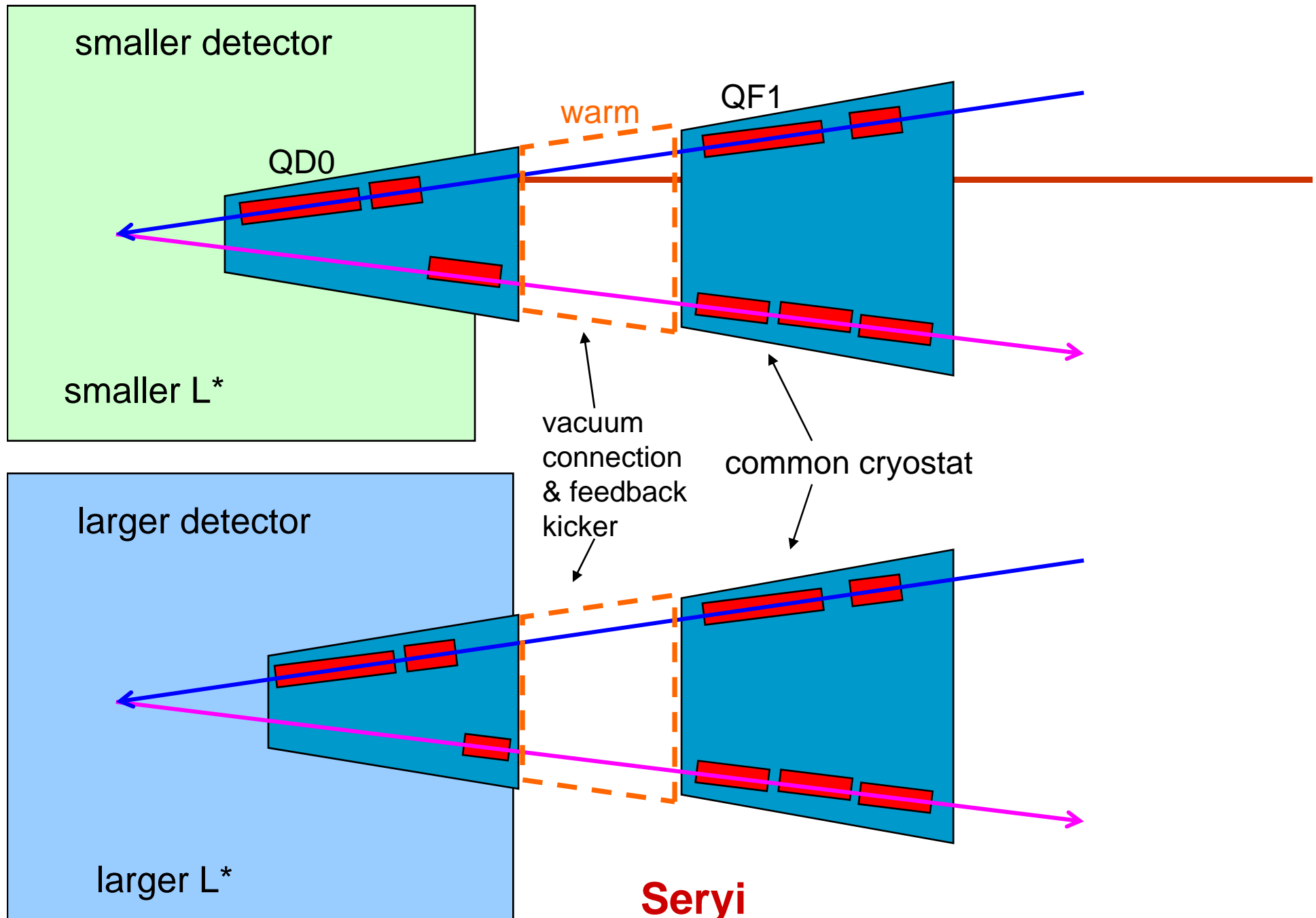

Seryi

Seryi Proposal: Fix QF1 @ 9.6m, L* chosen by Detector Concept: Study Collimation & Optics Sensitivity

Nominal positions near IP for push-pull

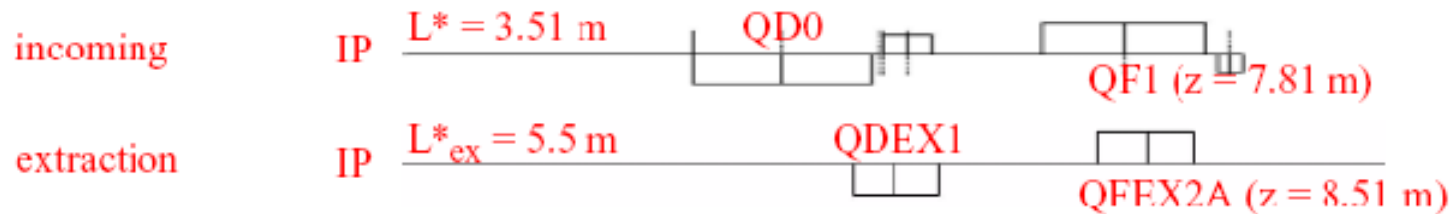

Modified positions near IP: QDEX1 moves along with QD0,
QF1 and QFEX2A are fixed at $z = 9.5 \text{ m}$ and 9.6 m , respectively.

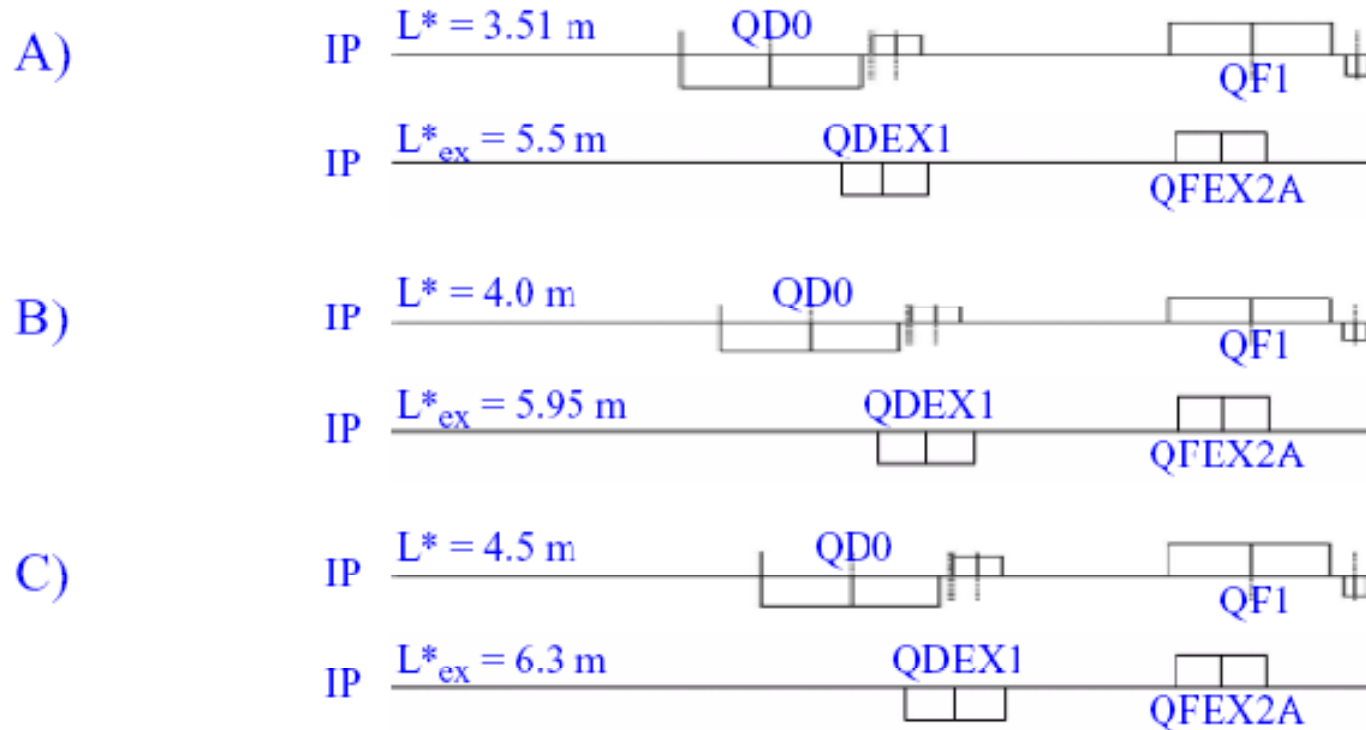

SiD $r < 50\text{cm}$, $L^* = 3.664$ Door Closed

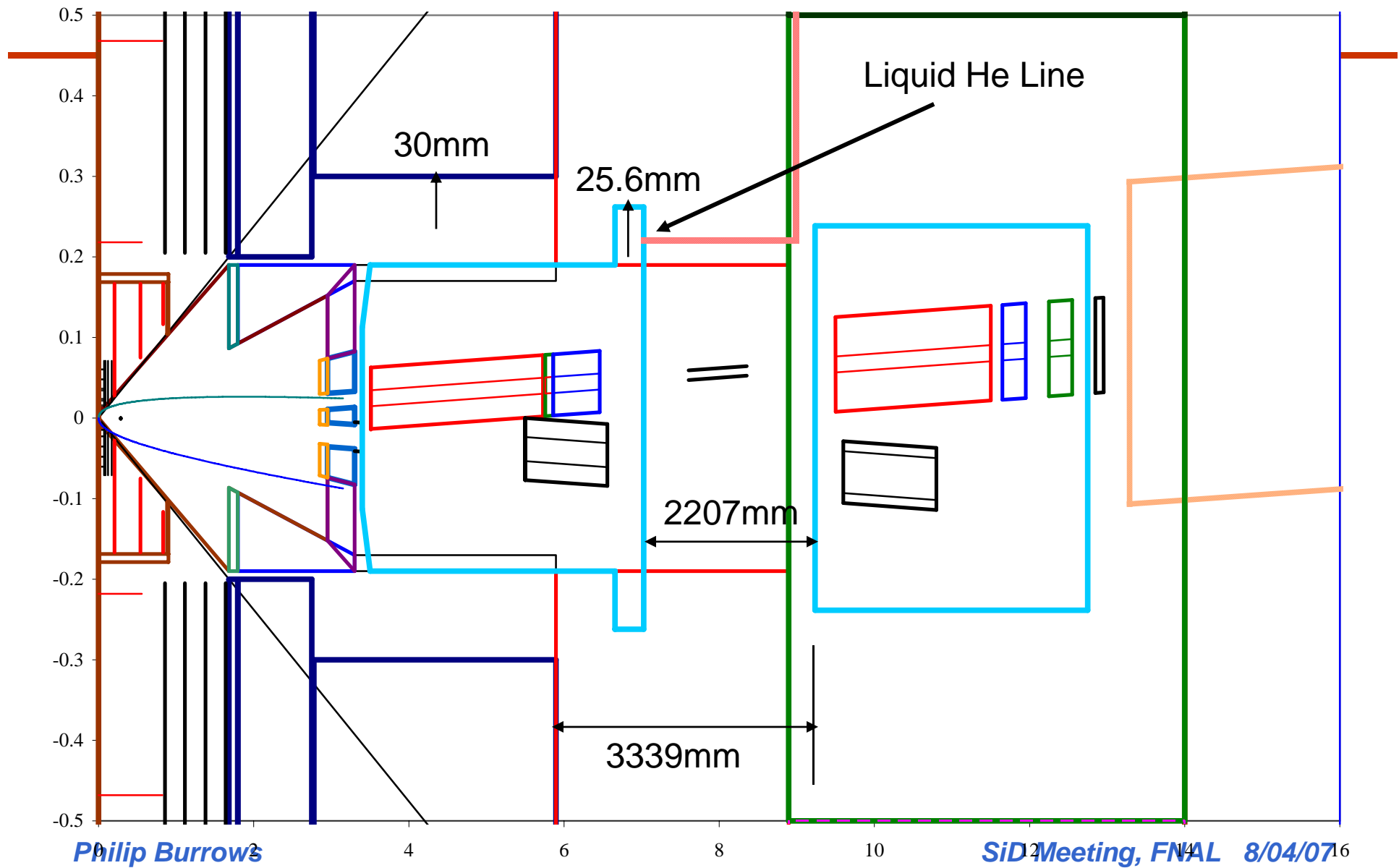

SiD $r < 50\text{cm}$, $L^* = 3.664$ Door Open

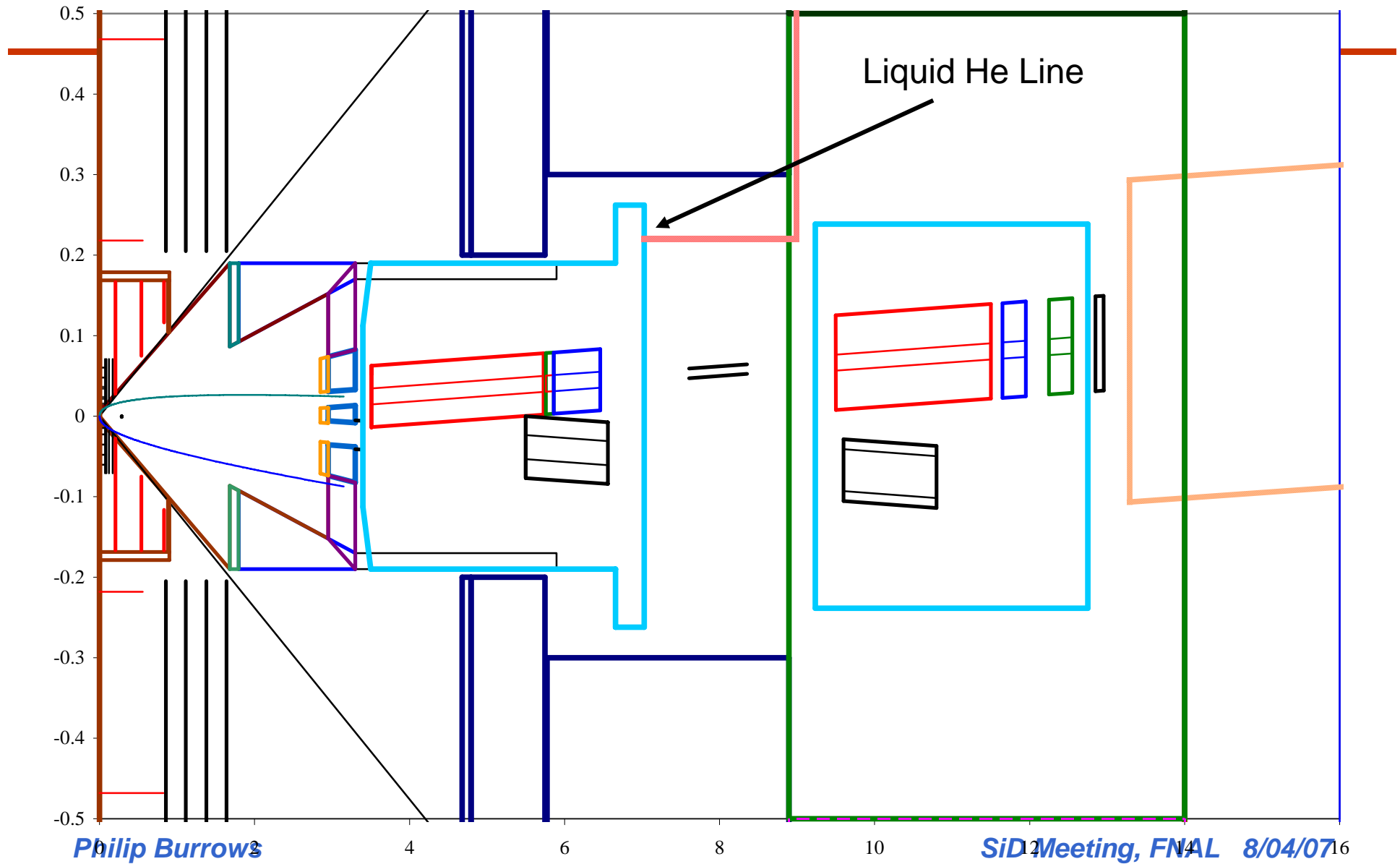

Door Closed, Permanent QD0 Liquid He Line

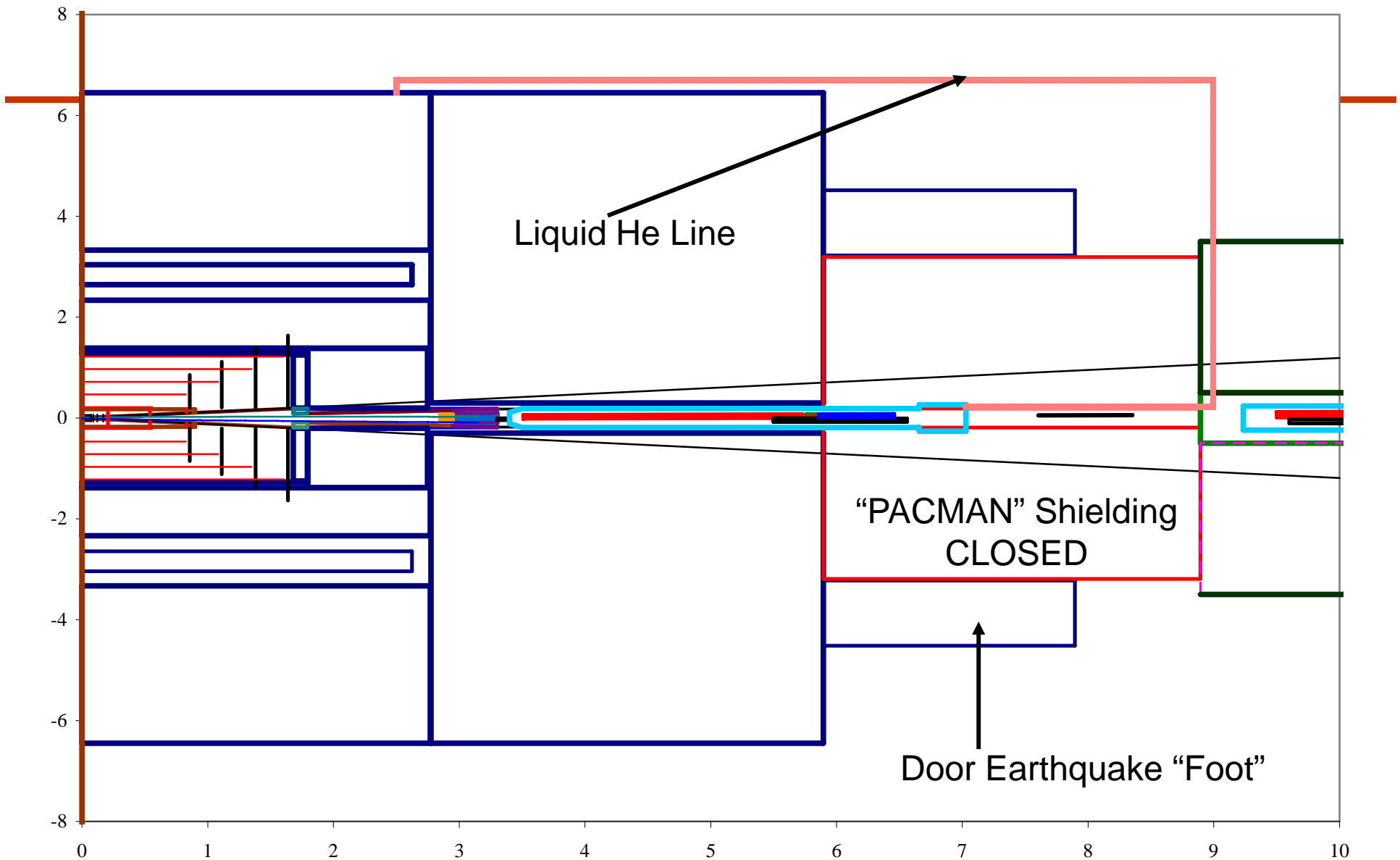

Door Open, Permanent QD0 Liquid He Line

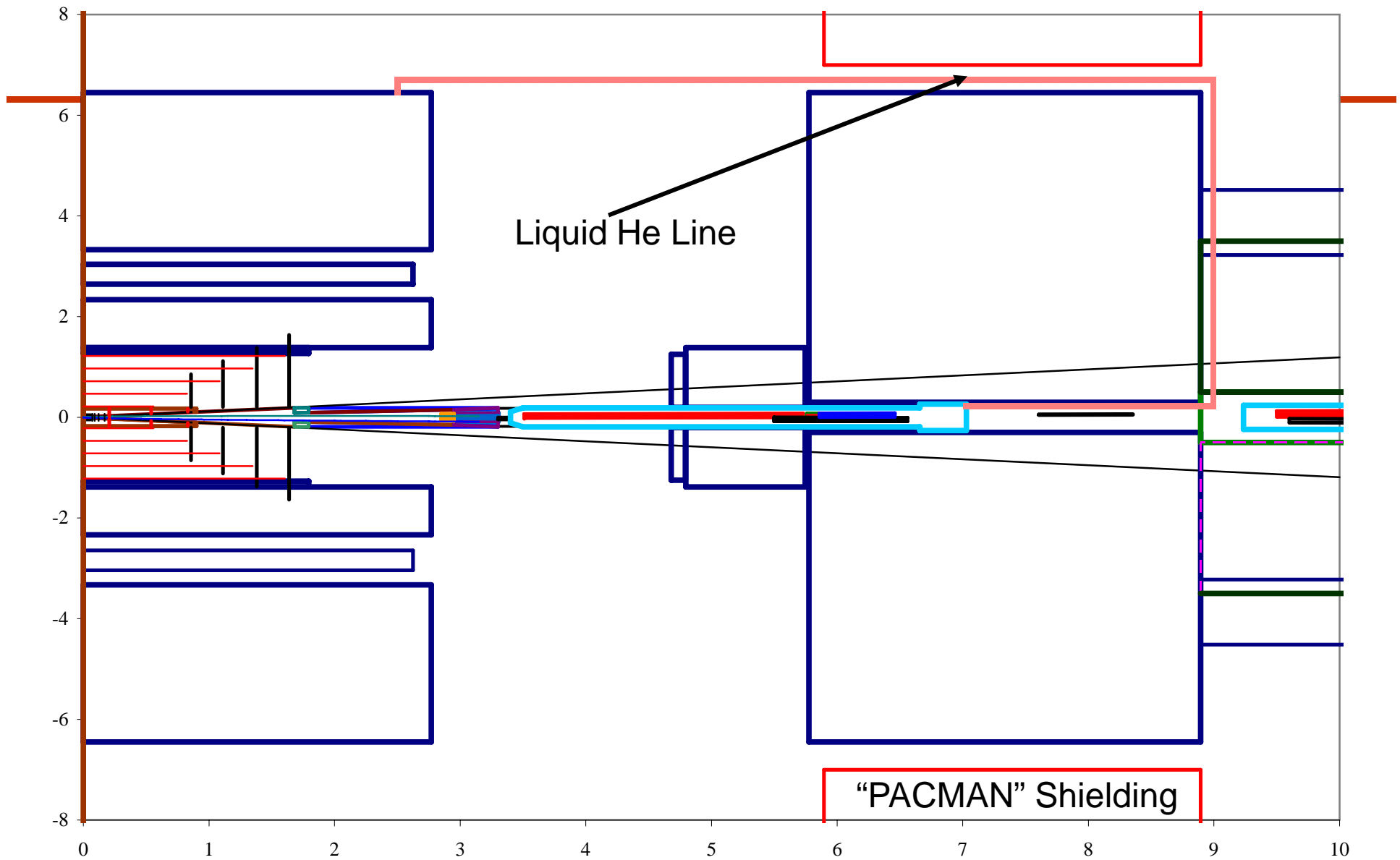

FCAL/QD0 Supported with Door Closed

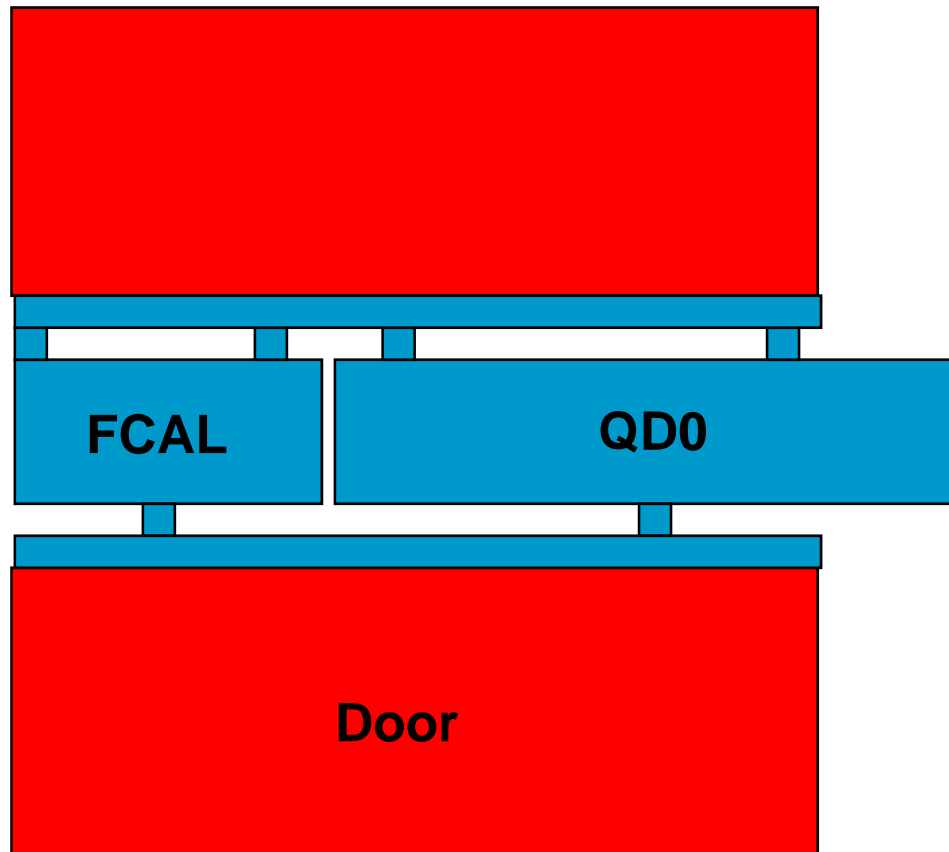

FCAL/QD0 Supported with Door Open

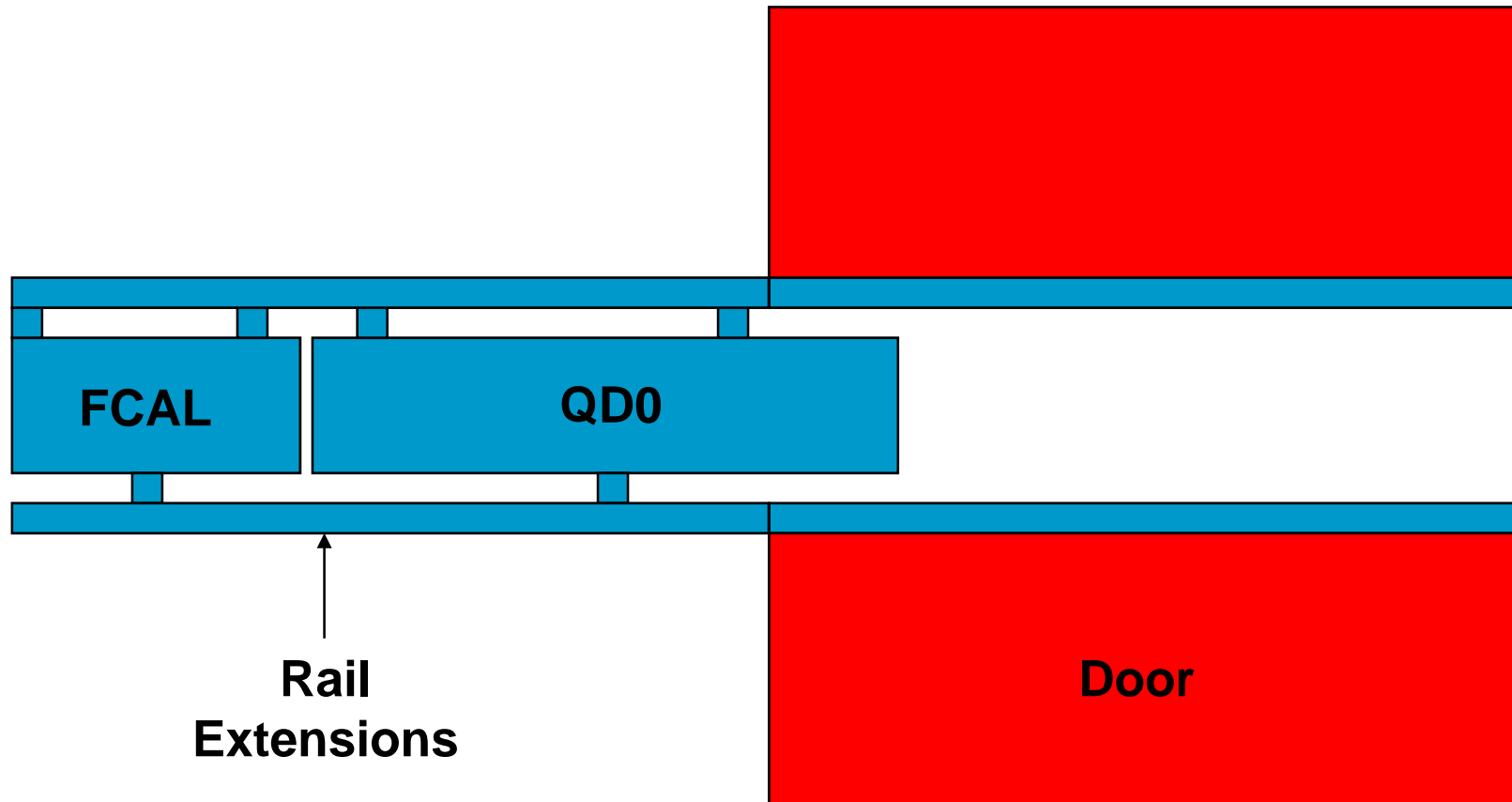

Detail of current beampipe (red)

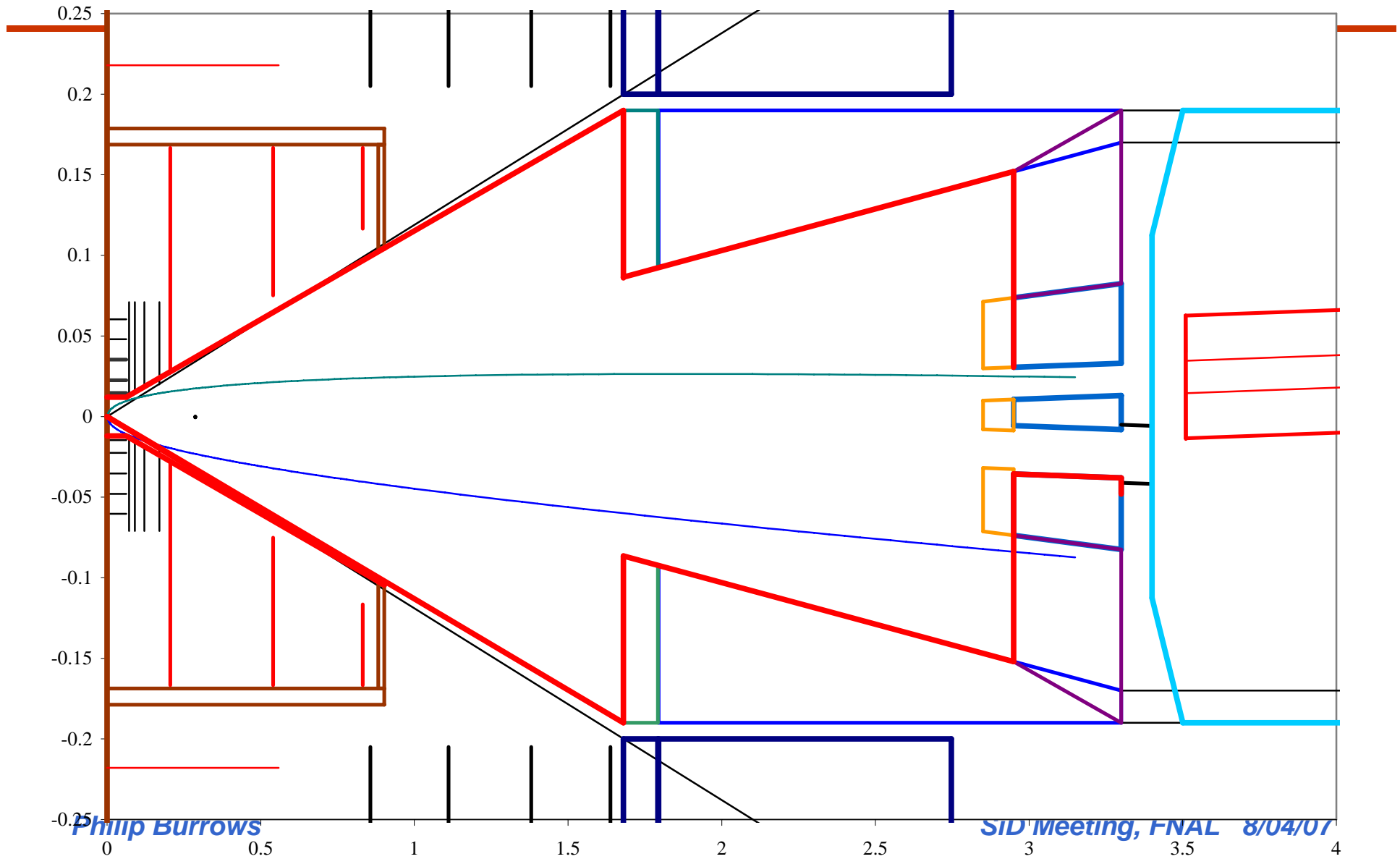

12mm Beam Pipe and VXD Detail

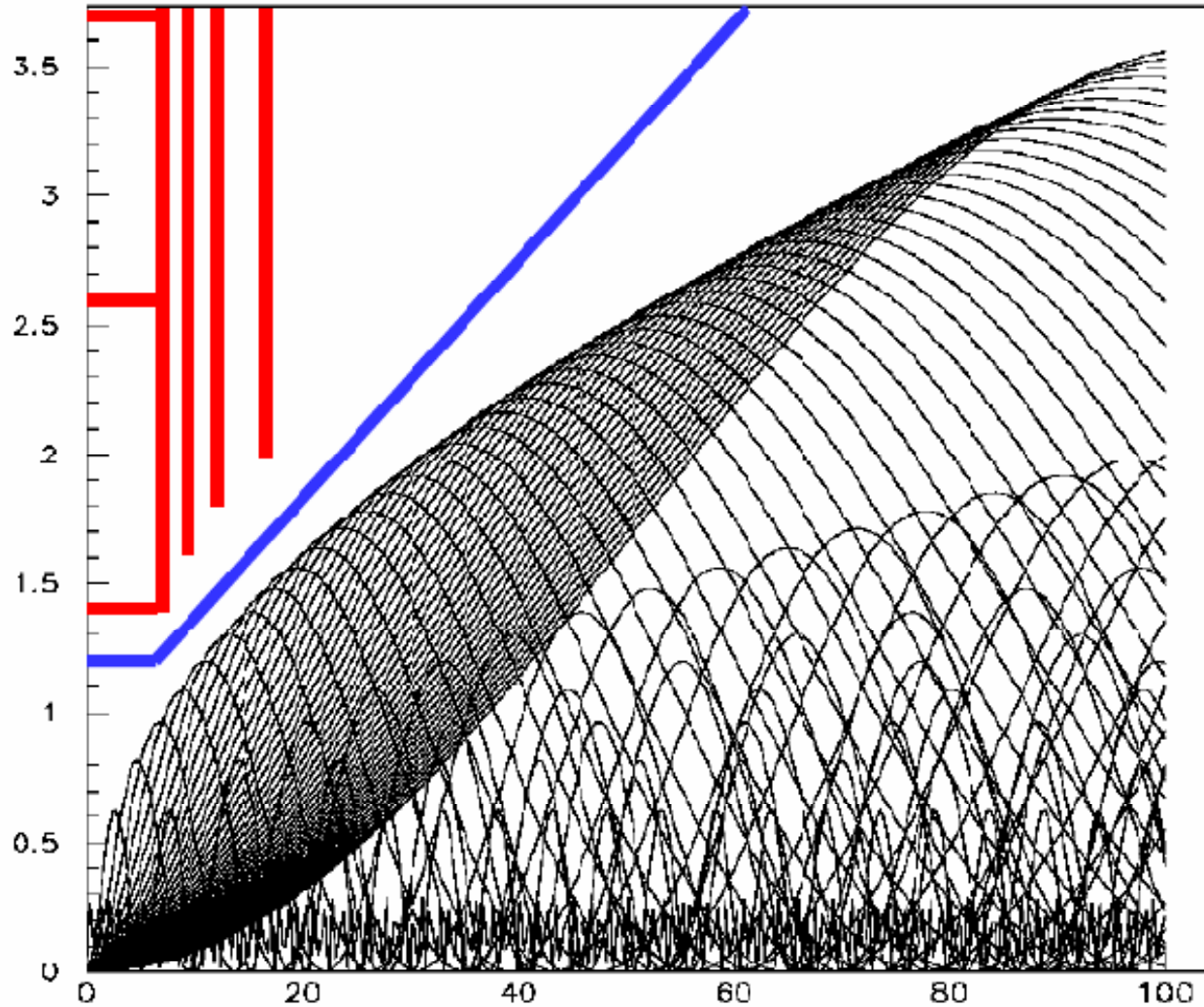

Three beampipe shapes have been considered over time for SiD

Flat at 12mm for VXD, flared to O.D. of Lumical (190mm) @ z_{\min}
= 1.68m of endcap ECAL

Flat at 12mm for VXD, flared to I.D. of Lumical (86.5mm) @ z_{\min}
= 1.68m of endcap ECAL

Flat at 12mm for VXD, flared rapidly to clear pair stay free until
 $r=86.5\text{mm}$ (r_{\min} of Lumical @ $z_{\min} = 1.68\text{m}$), then cylindrical

In all cases, beam pipe then becomes conic and follows inner surface of mask until beampipe

Conceptual Solution for R20 Mechanics is Needed

Support points

Bellows

Flanges

Alignment and adjustment features

Vacuum features (if any) at $z < 7\text{m}$ (end of QD0 cryostat)

Cable & Gas service routing

Rethinking of access requirements in PUSH-PULL

- **On-beamline access for rapid repair**
- **Off-beamline access for VXD or TRACKER replacement**

Parting comments

- **GDE RDR BDS baseline comprises a conceptual model of MDI based on push-pull + surface assembly**
- **Two BDS + IRs remain an ‘alternative’**
- **Engineering, engineering, engineering!**
 - ‘macroscopic’: buildings, shafts, caverns, cranes ...
 - ‘microscopic’: beampipes, valves, bellows, flanges ...
- **IR engineering workshop September 17-21**
- **Assume that MDI panel will continue (?) to provide input to EDR ...**

ILC IR Engineering Workshop

<http://www-conf.slac.stanford.edu/ireng07/>

Workshop on ILC Interaction Region Engineering Design

SLAC, September 17-21, 2007 (tentative)

Goal

To review and advance the design of the subsystem of the Interaction Region of ILC, such as

- Final focusing magnets
- Forward instrumentation
- Detector central regions
- IR vacuum chambers
- Cryogenic systems
- Supports for magnets and detectors
- Shielding
- Collider hall

focusing in particular on their integration, engineering and arrangements for push-pull operation.