



LLRF for ILC

S. Simrock, B. Chase
GDE



Requirements for ILC

- CM energy: 500 GeV. **Range 200 - 500 MeV.**
Upgradeability to **800 GeV**
- Luminosity and **reliability** of the machine should allow $L_{eq} = 500 \text{ fb}^{-1}$ four years
- Energy scans between 200 GeV and 500 GeV.
Energy change should take **less than 10%** of data taking time.
- Beam energy stability and precision should be below the **tenth of percent level**



RF Systems for ILC

- e^- and e^+ source
- Injectors
- Damping Rings
- **Main Linacs**
- Crab cavities at IP

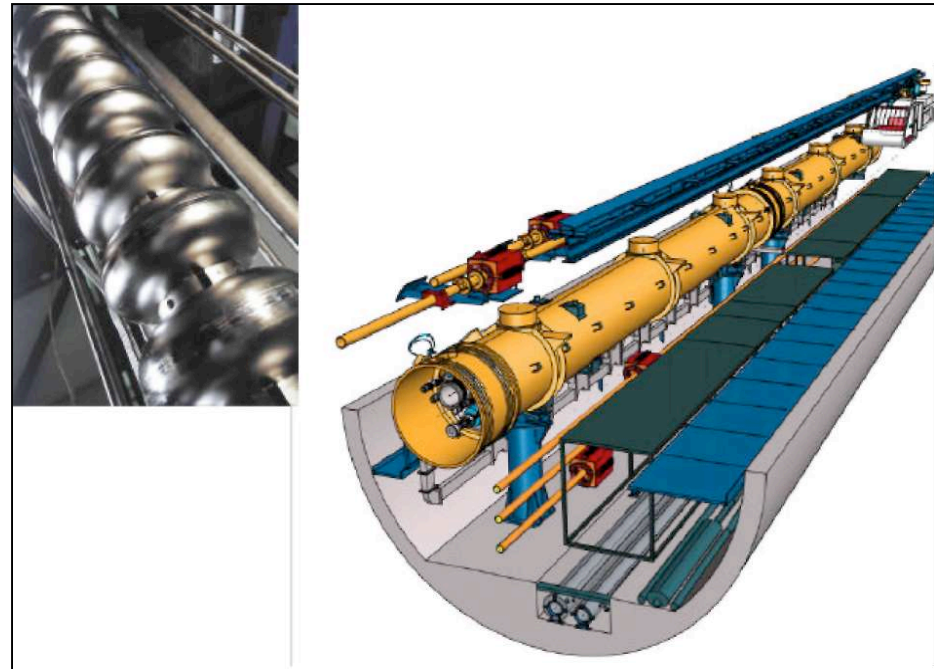



LLRF Requirements

- Maintain **Phase** and **Amplitude** of the accelerating field within given tolerances to **accelerate** a charged particle beam to given parameters
 - **up to 0.5% for amplitude and 0.03 deg. for phase**
- Minimize **Power** needed for control
 - RF system must be **reproducible, reliable, operable, and well understood.**
- Other performance goals
 - **build-in diagnostics** for calibration of gradient and phase, cavity detuning, etc.
 - provide **exception handling** capabilities
 - meet performance goals over wide range of operating parameters



Amplitude and Phase Stability

- Specification for LLRF Stability derived from Beam properties
 - Energy spread (intra-bunch, bunch-to bunch, long-term)
 - Intra-bunch $5e-4$ => desired bunch-to-bunch same order ($5e-4$) to limit chromatic effects (=> emittance growth)
 - Long term (usually time scale for thermal drift => beam based feedback)
 - Emittance (can increase as result of chromatic effects)
 - Arrival time jitter (will reduce luminosity)



Requirements for Main Linac

	phase tolerance limiting luminosity loss (deg)	phase tol. limiting incr. in energy spread (deg)	amplitude tolerance limiting luminosity loss (%)	amplitude tolerance limiting increase in energy spread (%)
correlated BC phase errors	.24	.35		
uncorrelated BC phase errors	.48	.59		
correlated BC amplitude errors			0.5	1.8
uncorrelated BC amplitude errors			1.6	2.8
correlated linac phase errors	large	.36		
uncorrelated linac phase errors	large	5.6		
correlated linac amplitude errors			large	.07
Uncorr. linac amplitude errors			large	1.05

Summary of tolerances for phase and amplitude control. These tolerances limit the average luminosity loss to <2% and limit the increase in RMS center-of-mass energy spread to <10% of the nominal energy spread.

Ref. Mike Church



Requirements for Crab Cavity

	timing tolerance limiting luminosity loss to < 2% (ps)	amplitude tolerance limiting luminosity loss to <2% (%)
RMS beam timing jitter	0.67	
RMS beam energy jitter		0.29
RMS cavity timing jitter (uncorrelated)	0.043	
RMS cavity timing jitter (anticorrelated)	0.032	
RMS cavity amplitude jitter		4.3

Summary of tolerances for crab cavity timing and amplitude control, and beam timing and energy for 20 mrad crossing angle. Considered separately, each of these tolerances will limit the average luminosity loss to <2%.

Ref. Mike Church



Crab Cavity Control Simulation

Cavity Response

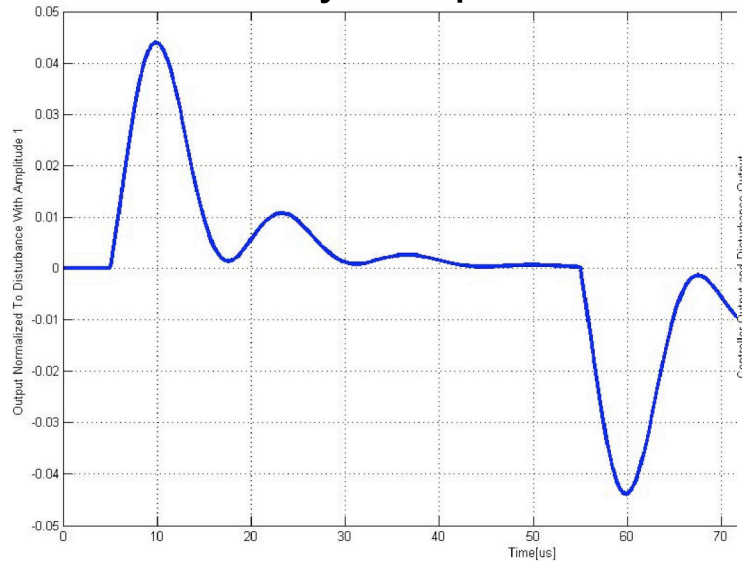

Disturbance and Controller Response

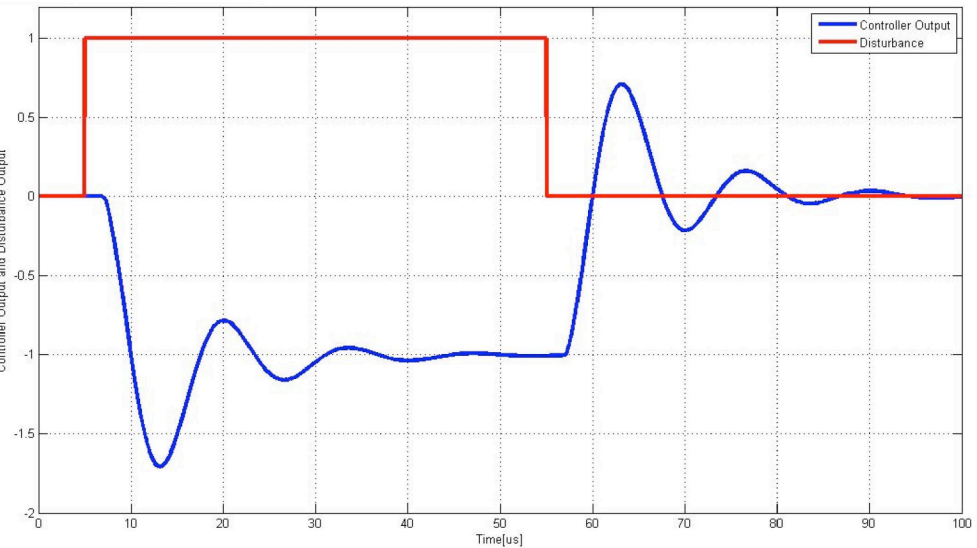

Cavity response to beam loading
Klystron in linear region
Voltage error: 4.5% of disturbance

Cavity BW : 2kHz
System Group Delay: 2 us
Proportional gain : 31
Integral gain : 2500000
CL Bandwidth: 62kHz



Scope of Main Linac LLRF

total number of klystrons / cavities per linac	~ 350/ 8,400
per rf station (klystron):	
# cavities / 10 MW klystron	~ 26
# of precision vector receivers (probe, forward, reflected power, reference line, beam)	~90
# piezo actuator drivers / motor tuners	~ 26/26
# waveguide tuner motor controllers	~ 26
# vector-modulators for klystron drive	1
Total # of meas. / control channels per linac	~30,000 / ~30,000



Requirements

- Reliability
 - not more than 1 LLRF system failure / week
 - minimize LLRF induced accelerator downtime
 - Redundancy of LLRF subsystems
 - ...
- Operability
 - “One Button” operation (State Machine)
 - Momentum Management system
 - Automated calibration of vector-sum
 - ...
- Reproducible
 - Restore beam parameters after shutdown or interlock trip
 - Recover LLRF state after maintenance work
 - ...



Requirements

- Maintainable
 - Remote diagnostics of subsystem failure
 - “Hot Swap” Capability
 - Accessible Hardware
 - ...
- Well Understood
 - Performance limitations of LLRF fully modelled
 - No unexpected “features”
 - ...
- Meet (technical) performance goals
 - Maintain accelerating fields - defined as vector-sum of 24 cavities - within given tolerances
 - Minimize peak power requirements
 - ...



Sources of Perturbations

o <u>Beam loading</u>	o <u>Cavity dynamics</u>
- Beam current fluctuations	- cavity filling
- Pulsed beam transients	- settling time of field
- Multipacting and field emission	
- Excitation of HOMs	o <u>Cavity resonance frequency change</u>
- Excitation of other passband modes	- thermal effects (power dependent)
- Wake fields	- Microphonics
	- Lorentz force detuning
o <u>Cavity drive signal</u>	
- HV- Pulse flatness	o <u>Other</u>
- HV PS ripple	- Response of feedback system
- Phase noise from master oscillator	- Interlock trips
- Timing signal jitter	- Thermal drifts (electronics, power amplifiers, cables, power transmission system)
- Mismatch in power distribution	



RF System Architecture (Simplified)

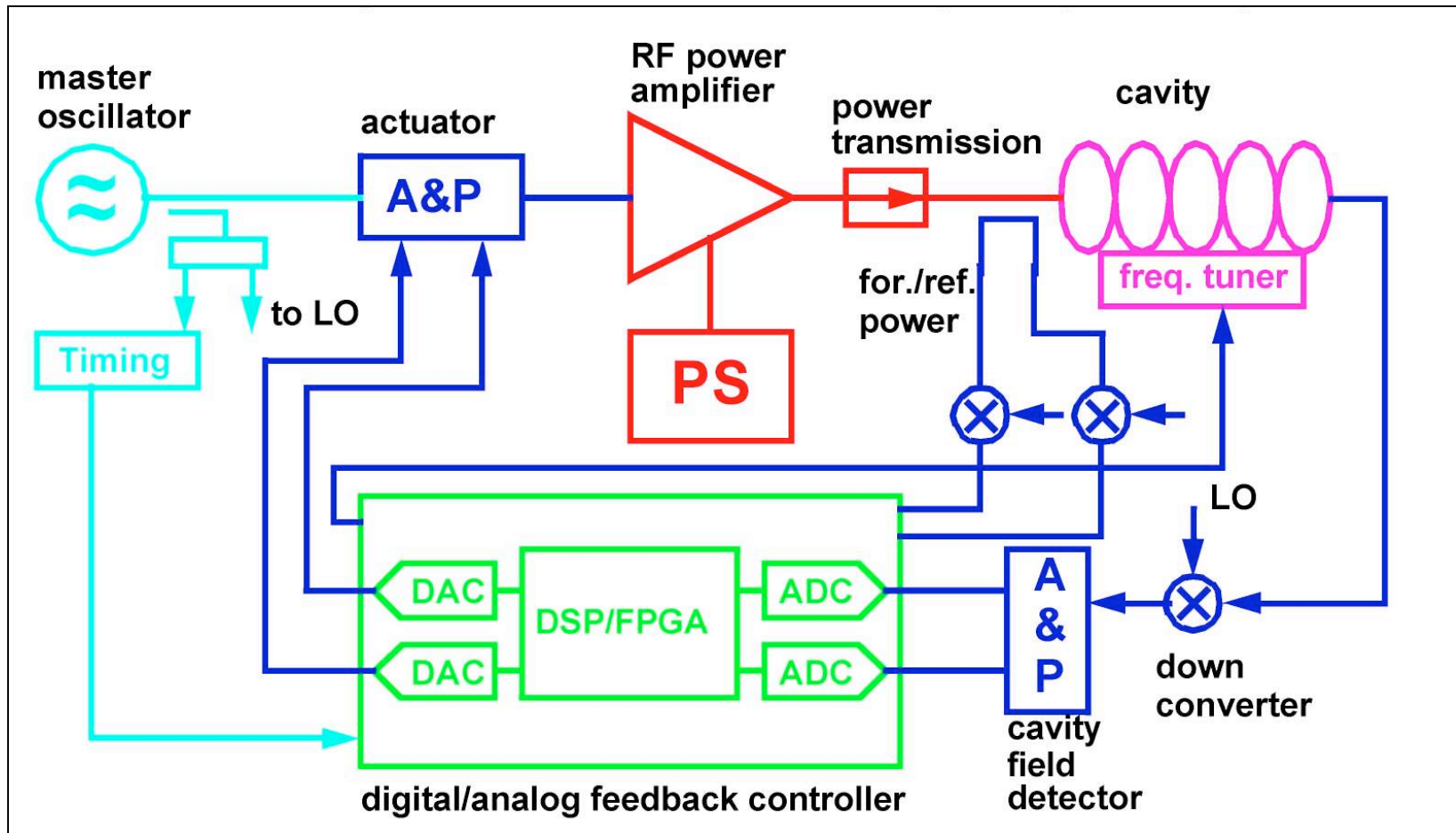



Typical Parameters in a Pulsed RF System

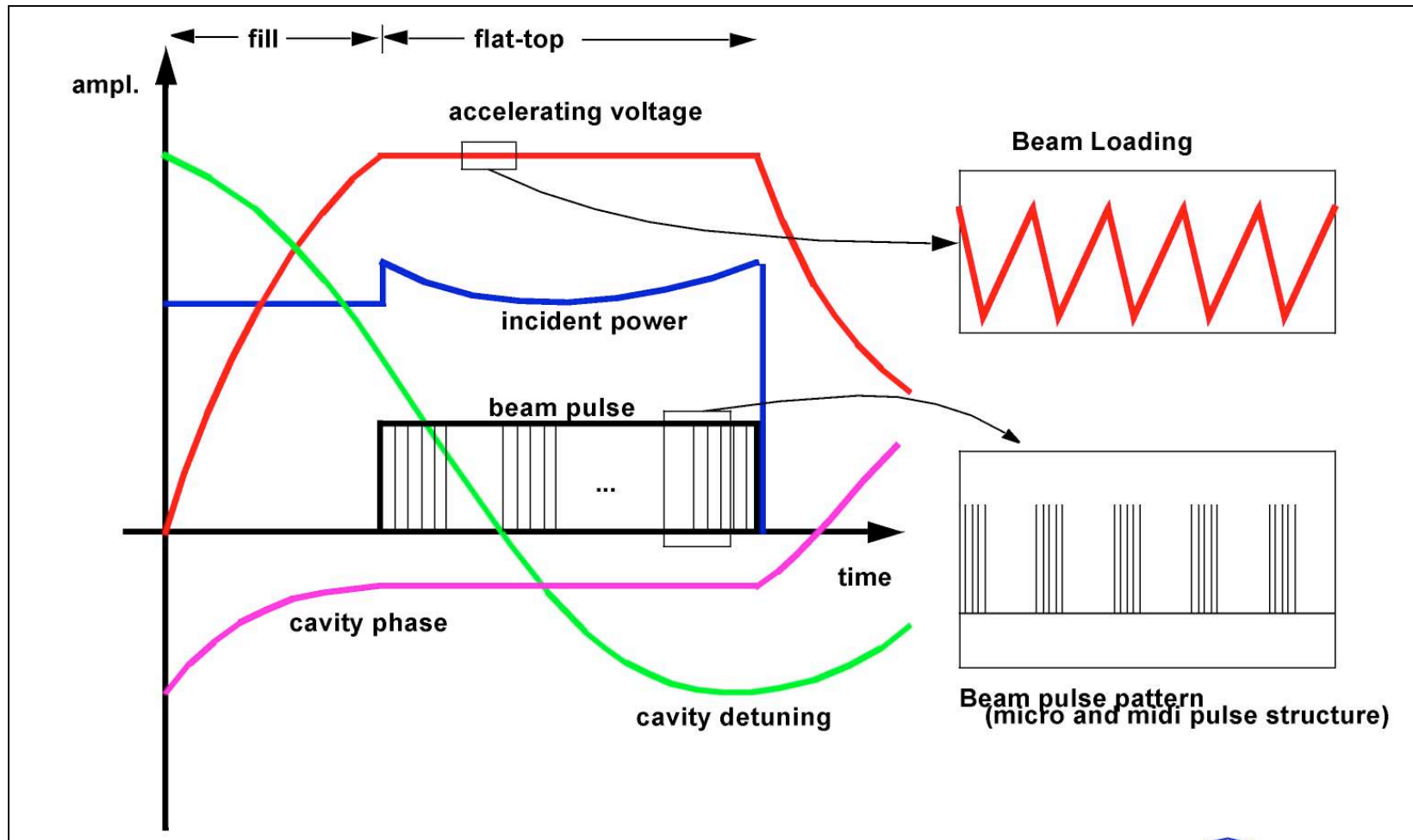



Architecture of Digital RF Control

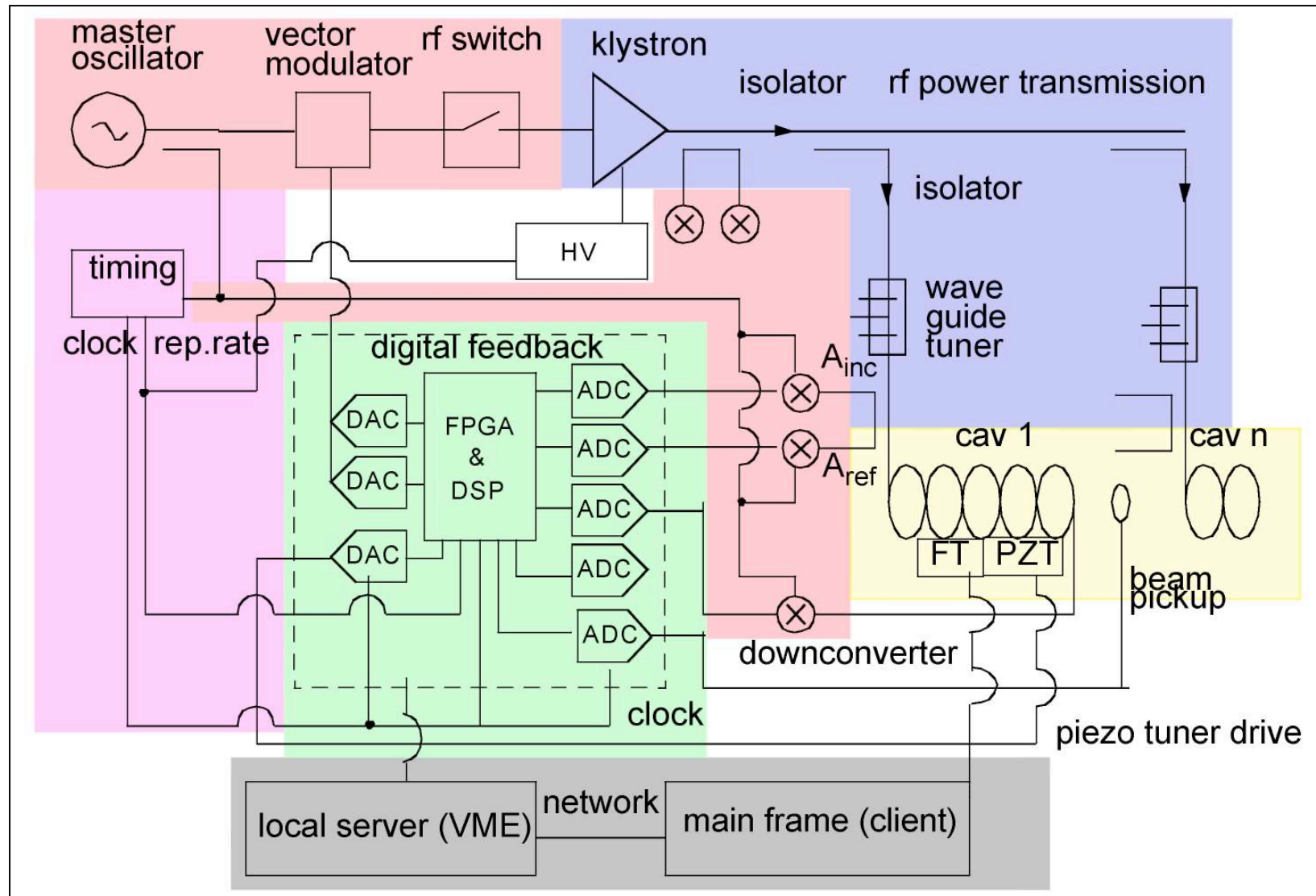



Error Map

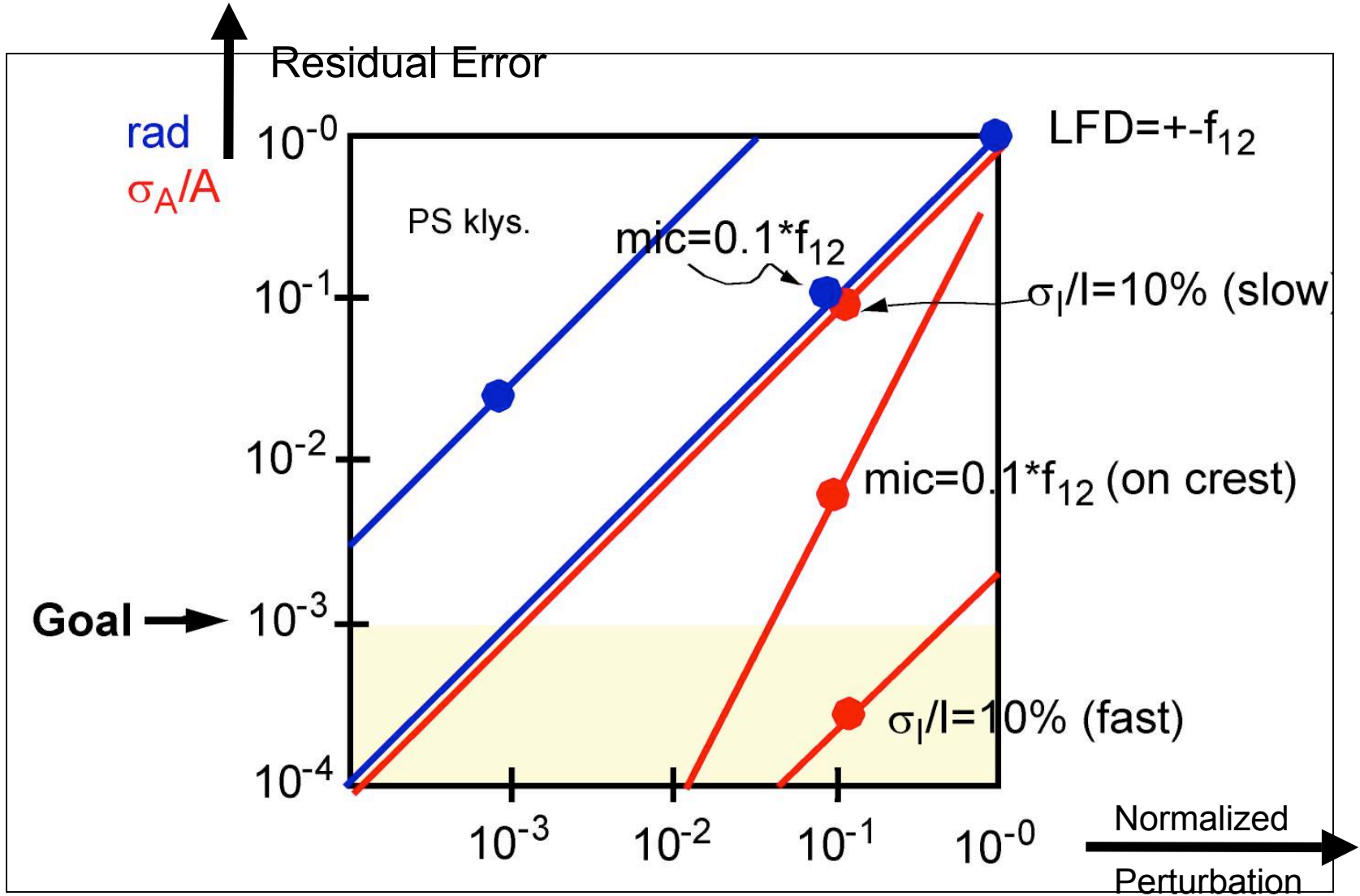



RMS Error as Function of Gain

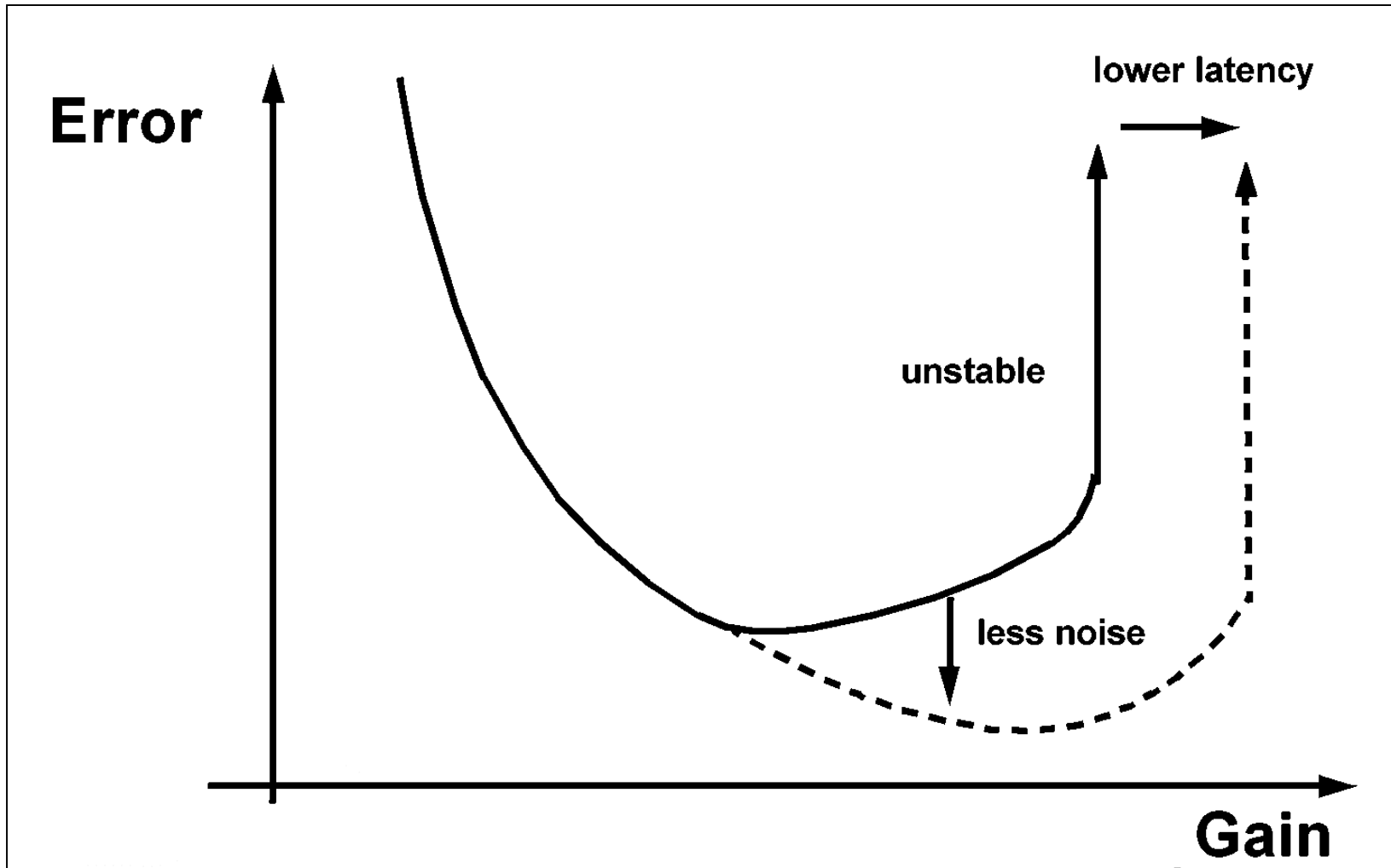



Field Regulation at FLASH

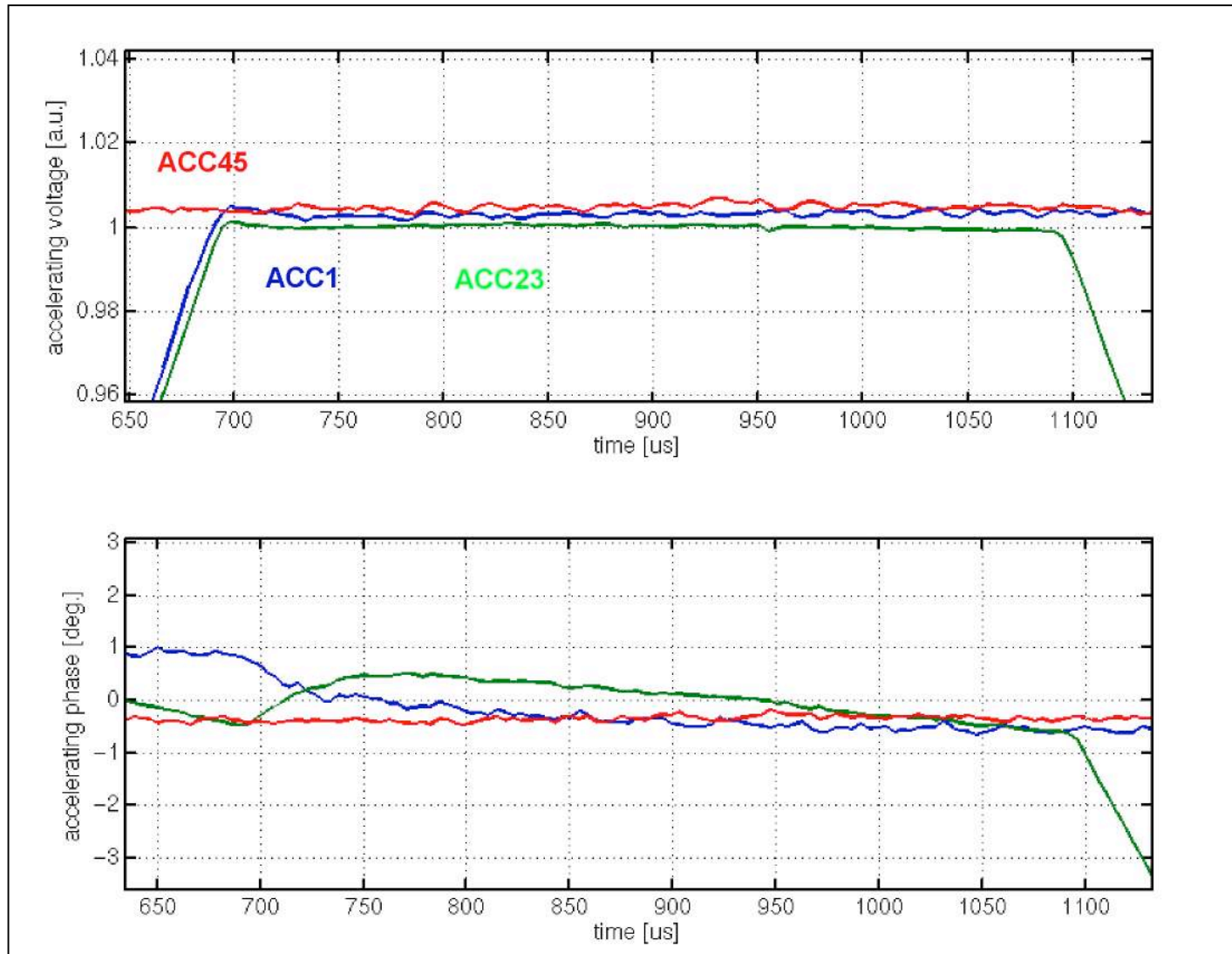



Field Regulation at FLASH

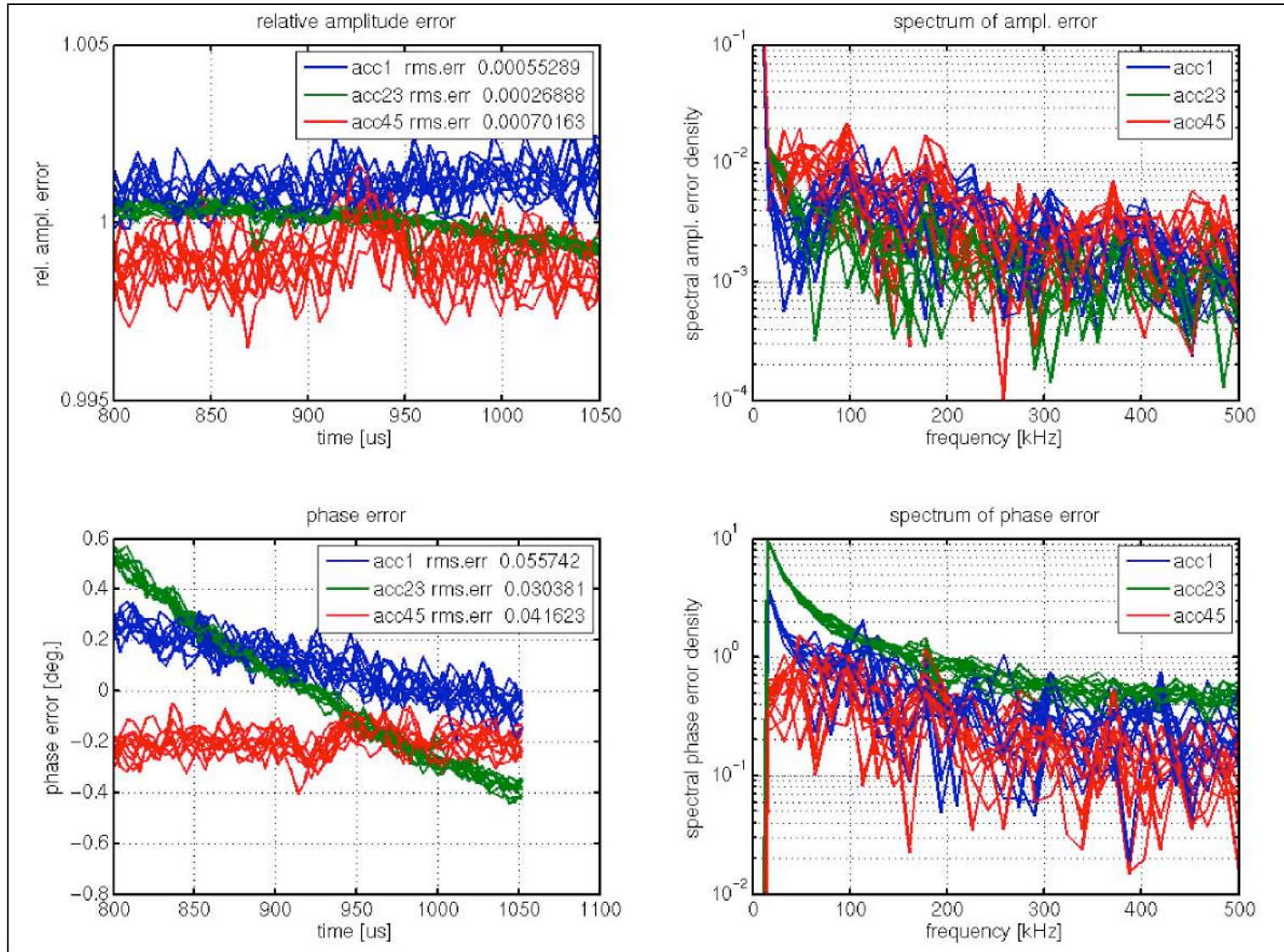



Field Regulation at FLASH

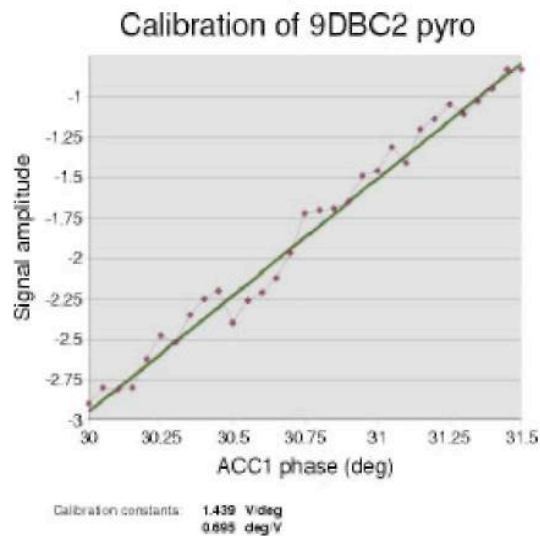
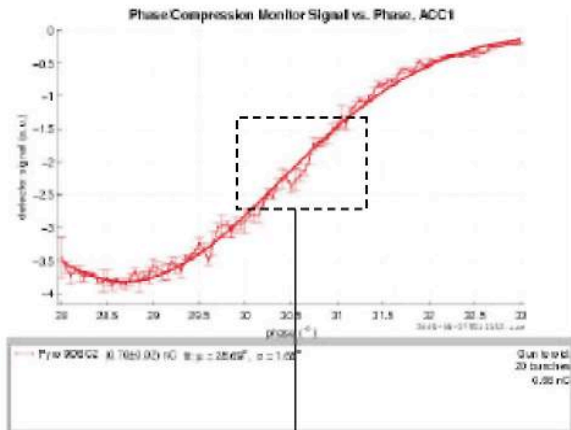

Phase stability of ACC1, Cal = 72.0mV/deg; save =2005-08-27T222223-ac1

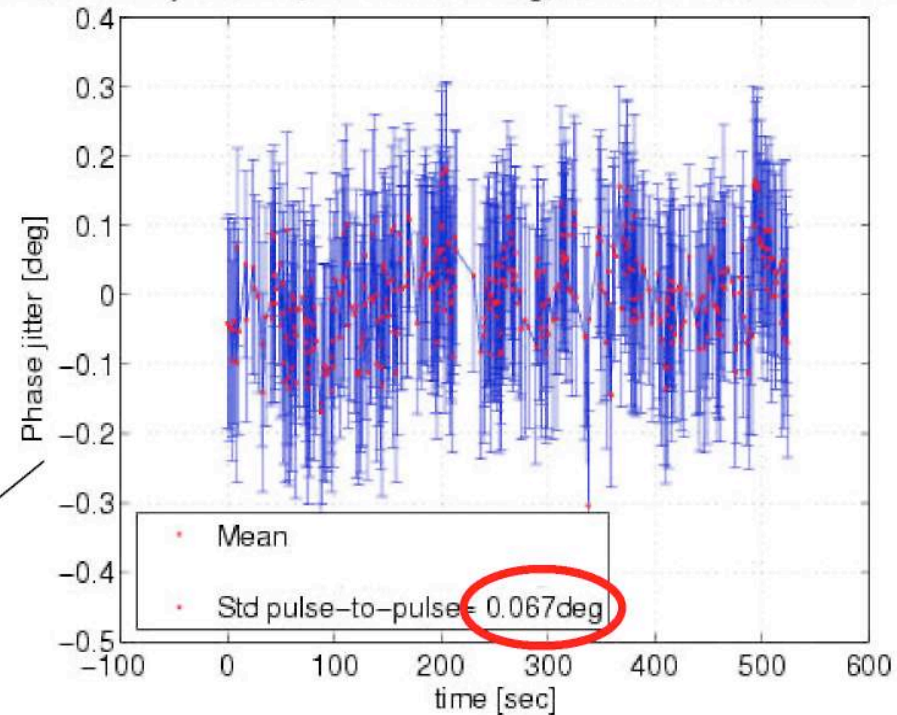

But! This is the phase stability between the beam arrival into the acceleration module relative to the RF phase!!!

=> Major contribution is likely from laser



Challenges for RF Control

- Topics
 - **Vector-Sum Calibration (Ampl. & Phase)**
 - **Operation close to performance limits**
 - **Exception Handling**
 - **Automation of operation**
 - **Piezo tuner lifetime and dynamic range**
 - **Optimal field detection and controller (robust)**
 - **Operation at different gradients**
 - **Defining standards for electronics (such as ATCA)**
 - **Interfaces to other subsystems**
 - **Reliability**



Beam Based Calibration

- Minimum Beam loading required (240 nC, 30us)
- Phase calibration to 3 deg.
- Gradient calibration 3-5%

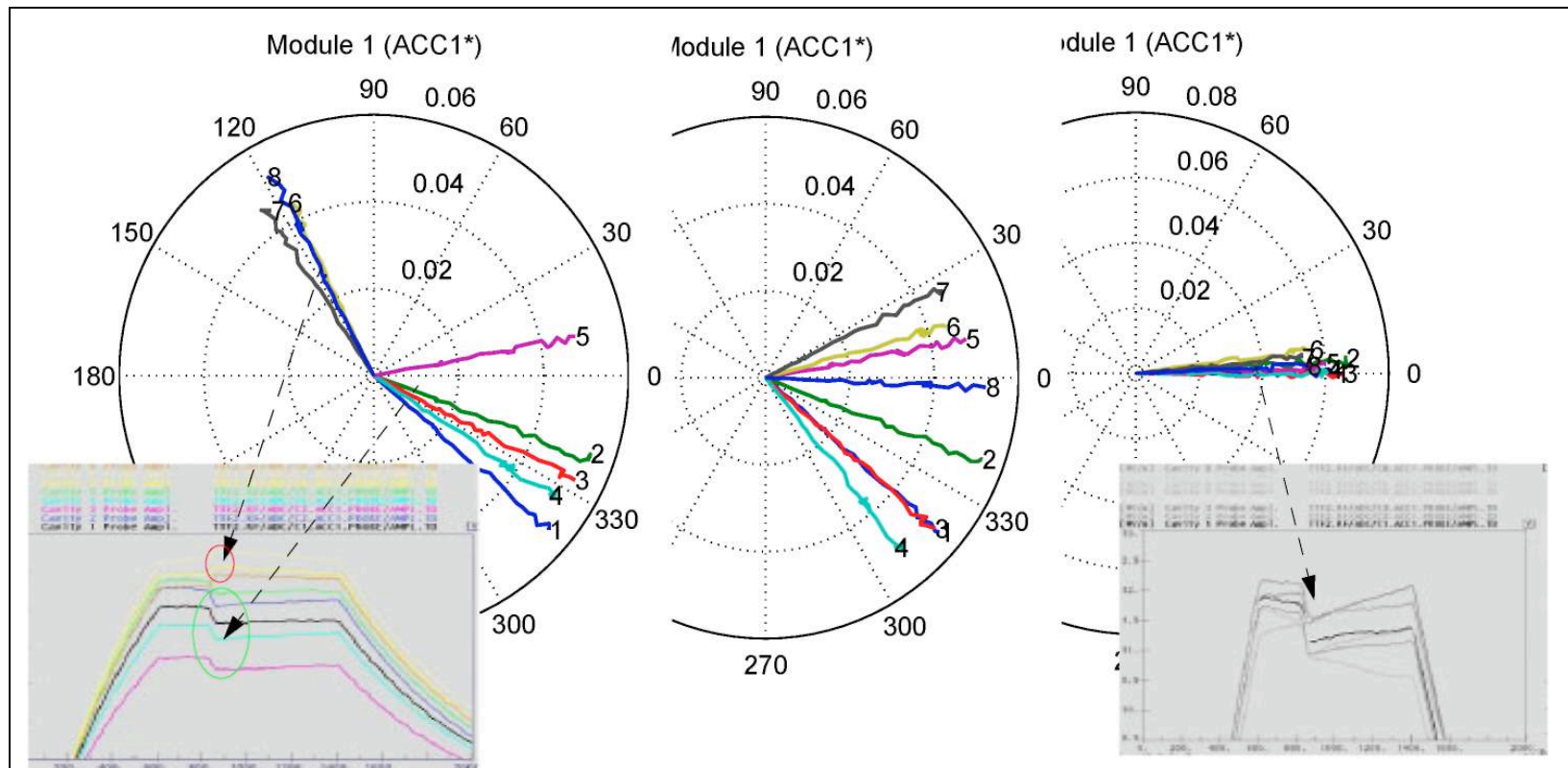



Vector Sum Calibration

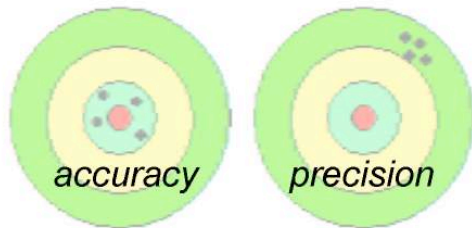

How precise can we measure the vectorsum seen by the beam (not: how good can we control the vectorsum...). We are not interested in *accuracy* but in *precision*!

Every vector carries an error that is assumed to be constant:

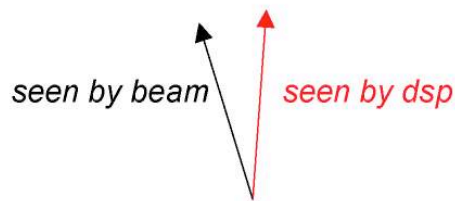

Two extreme configuration: the dsp sees identical vectorsums but the beam does not!

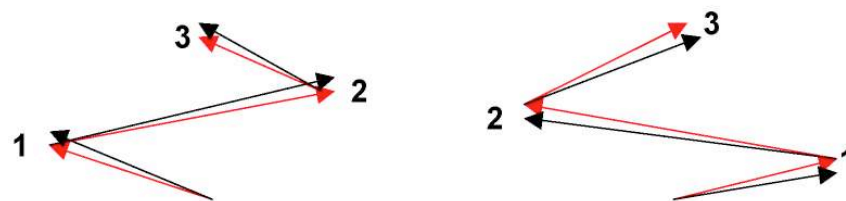



Vector Sum Calibration

Number of cavities: 1,12,32,64, Predetuning: 50 Hz, Detuning-Spread: 11 Hz, Amplitude cal. error: 0.01

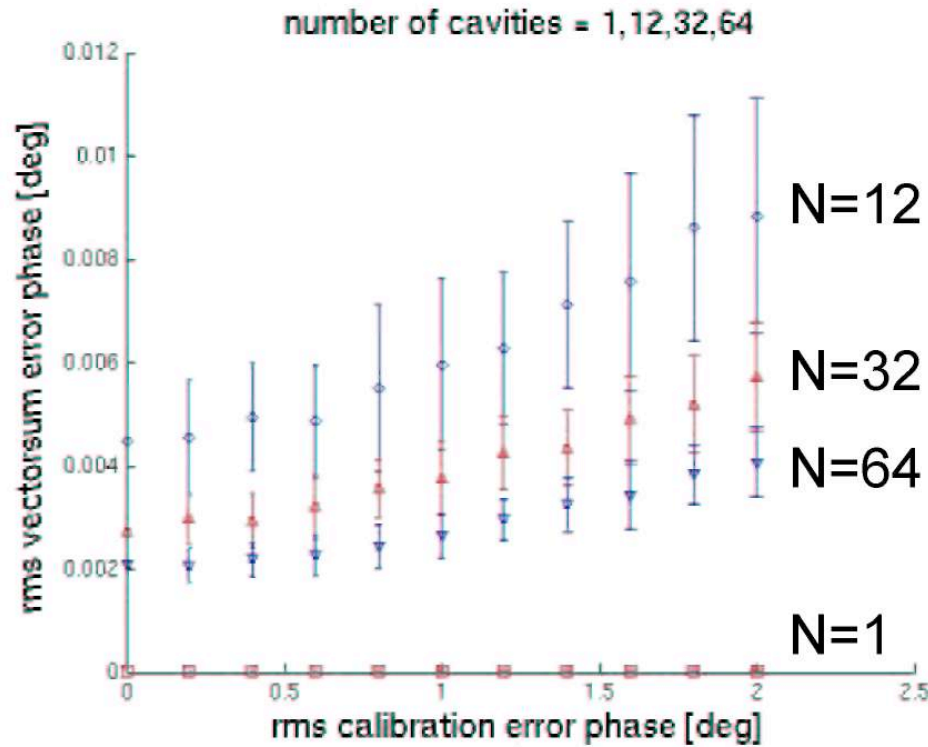

Surprising result: the more we measure, the better we get!



Automation ex.: Adapt. Feedforward

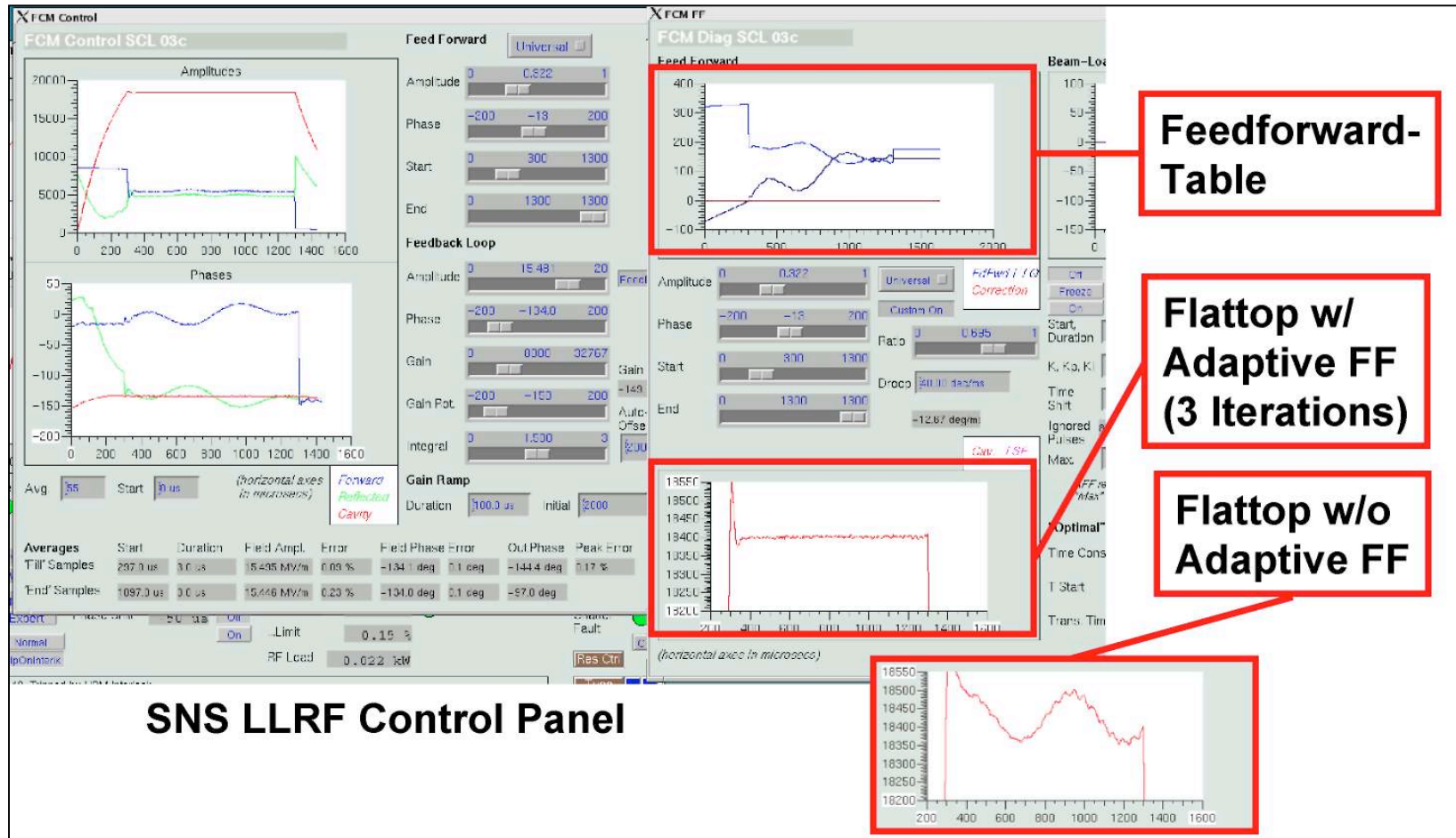



Operation at Different Gradients

Variations in Loaded Q

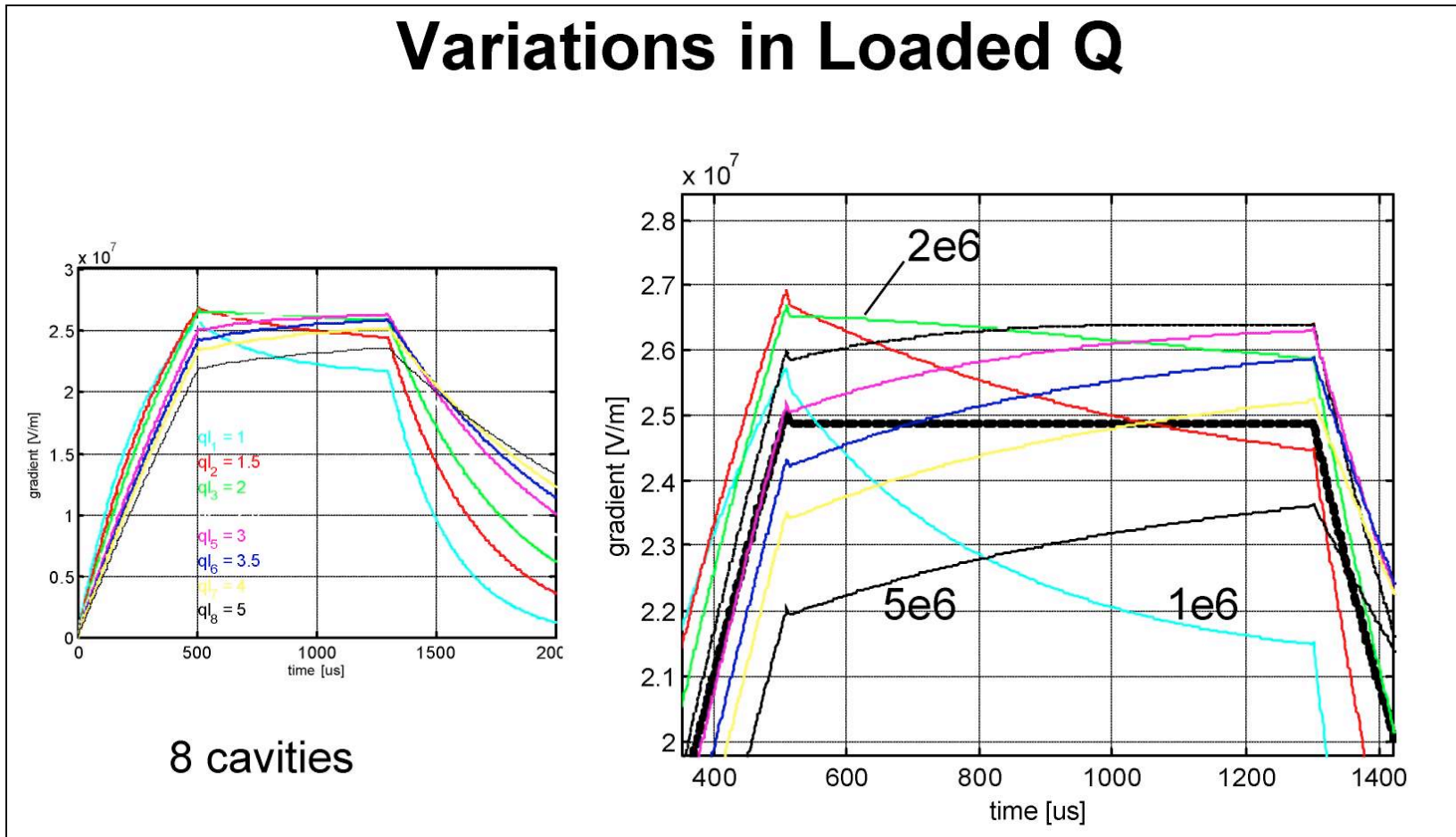



Subsystems Susceptible to Failure

- | | |
|--|---|
| <ul style="list-style-type: none">o RF phase reference<ul style="list-style-type: none">- from main driveline- LO for downconvertero Timing Systemo Vector modulatoro Downconvertero Digital Control (Fdbck + FF)<ul style="list-style-type: none">- ADC, DSP, DAC- includes exception handling- Redundant simple feedforward- Redundant monitoring systemo Transient detectiono Interfaces to other subsystems<ul style="list-style-type: none">- includes interlocks | <ul style="list-style-type: none">o Waveguide tuner and controlso Cavity resonance control<ul style="list-style-type: none">- slow (motor) tuner- fast (piezo) tunero CPU in VME crateo Network to local controlso Cabels and connectorso Power supply for electronicso Airconditioning in rackso Software<ul style="list-style-type: none">- DSP (FPGA) code- Server programs- Client programs- LLRF Parameters- Finite State Machine |
|--|---|



Reliability

- **Some examples (rough numbers)**

- **PC motherboard** **50 kh**
- **VME CPU** **180 kh**
- **Fan** **60 kh**
- **Power supply** **50 kh .. 400 kh**
- **SCSI disk** **1 000 kh**
- **IDE** **300 kh**



Evolution of Hardware at SNS

1st Generation
Control Chassis

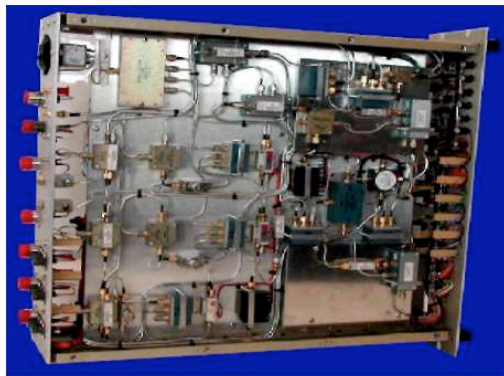

MEBT Rebunchers
4 installed, 1 spare
Retrofitted with FCM
Nov 04

2nd Generation
Control Chassis



RFQ & DTL
7 installed, 3 spares
Retrofitted with FCM
Jul 04

3rd Generation
Field Control Module



CCL, SCL & HEBT
Retrofit to MEBT, RFQ & DTL
98 systems + spares

Evolutionary Development: build on proven concepts, hardware and software

October 10, 2005



Lesson Learned

- Document the system requirements.
 - Avoid feature creep.
- Document the development plan.
- Make a resource-loaded schedule and budget.
- Use proven solutions. Don't reinvent the wheel. Resist the “not invented here” syndrome.
- Keep it simple.
- If your schedule is at risk, ask for help.
- Your team must “take ownership” of the system.
- Software support and development is an integral and essential part of the process.
- Be willing to cross functional and subsystem boundaries.
- Avoid dictating the choice of software tools and languages if possible.

Ref. M. Champion



Advice for Hardware Development

- Avoid early parts obsolescence.
- Install a RF PIN switch diode on your RF output.
- Install extra channels – you will need them later!
- Verify your parts can withstand a wet wash process following SMT assembly.
- Do not use epoxy-mount components (difficult to replace)
- Provide adequate shielding between motherboard and daughterboard.
- Provide “clean” DC power to your circuits.
 - Beware of DC-to-DC switching supplies. The switching frequency (usually 200 kHz) will find its way into your system!
- Don't waste your time building cables. Let a vendor do it.
- Use a symmetric layout for your ADC clock distribution and pay attention to impedance matching.
- Think about how you will test, troubleshoot and repair your circuit boards when you do your board design and layout (not after you receive the circuit boards)

Ref.: M. Champion



RF Station with 3 Cryo-modules

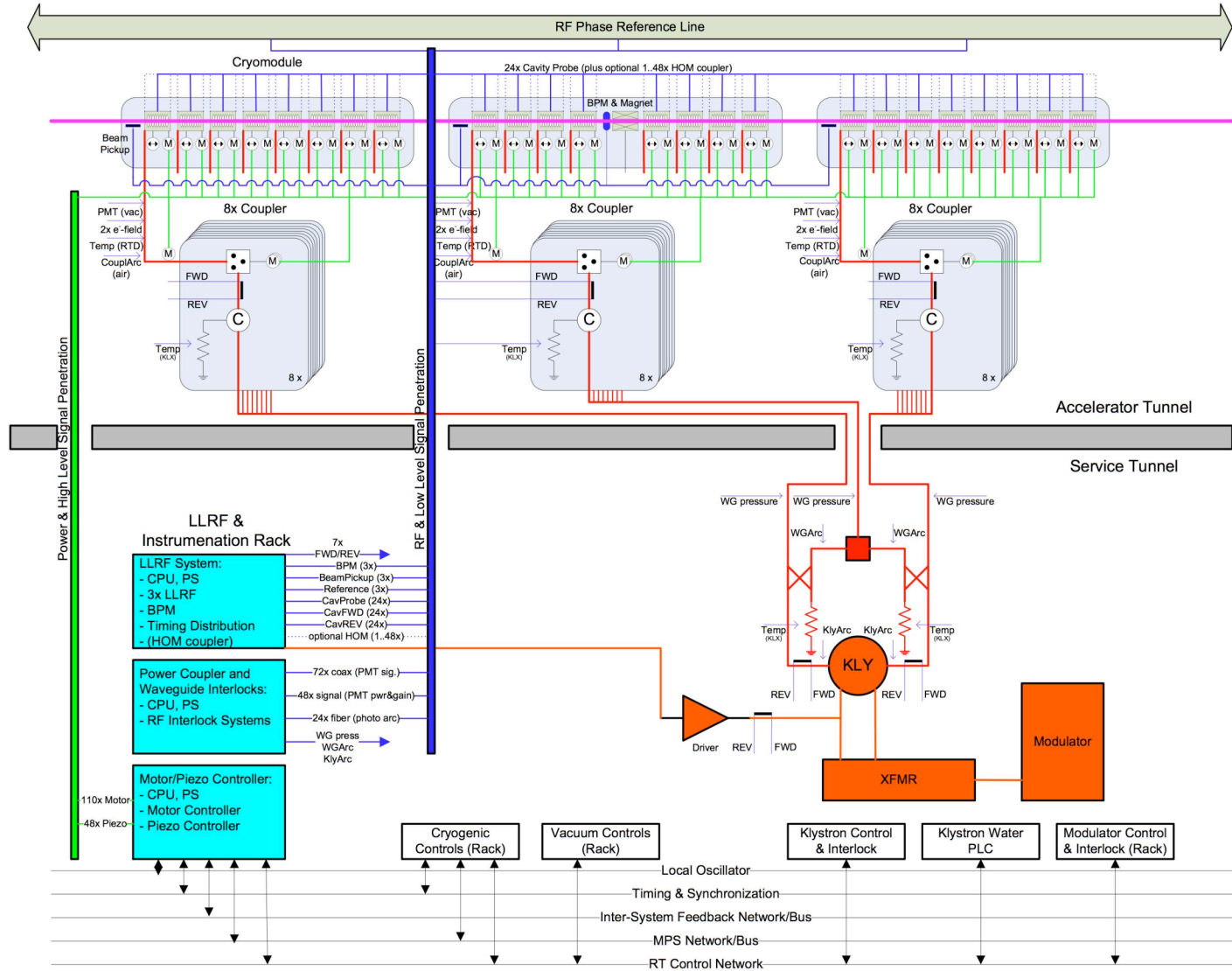



Rack Layout

LLRF/Instrumentation Racks

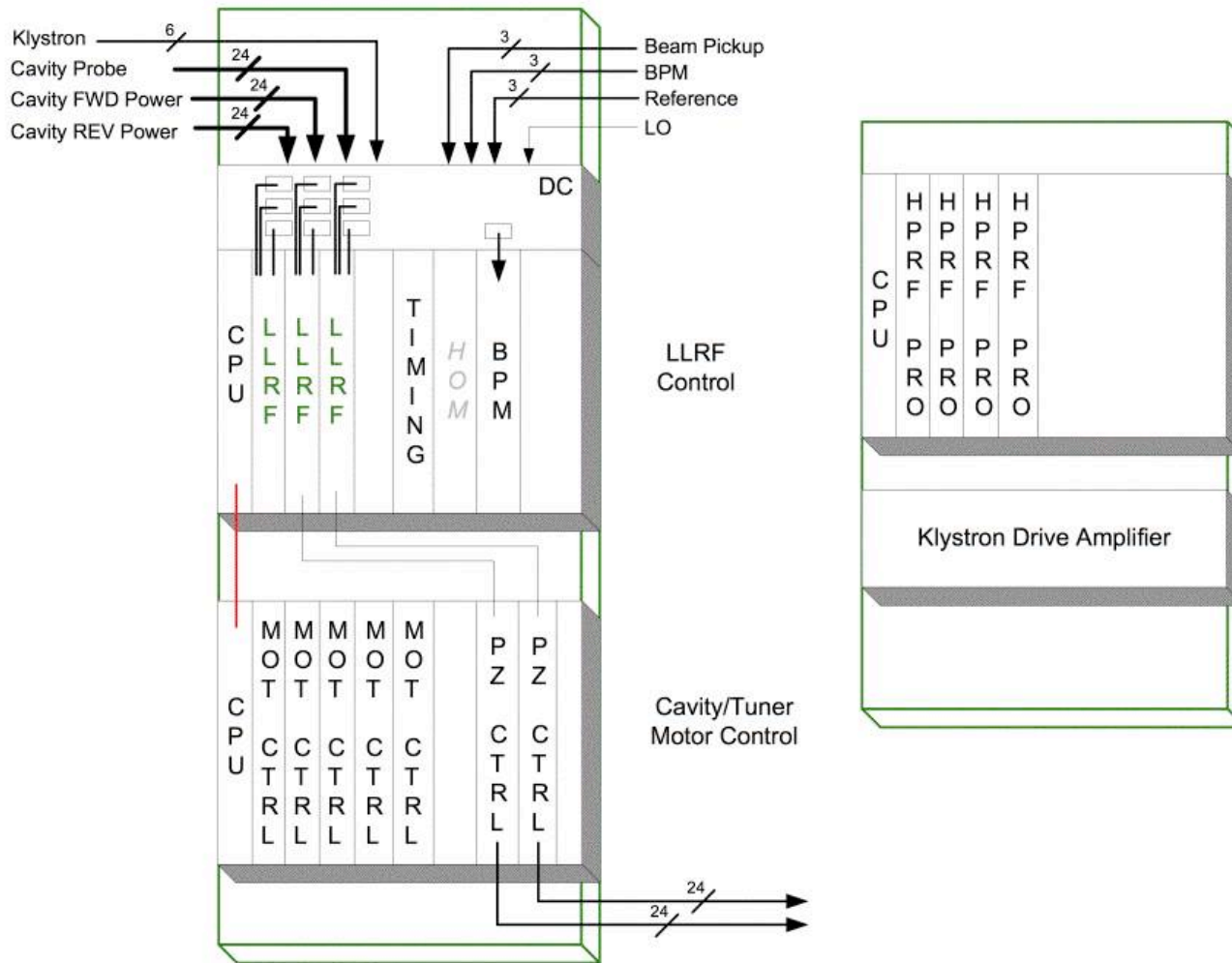



LLRF Rack Detail

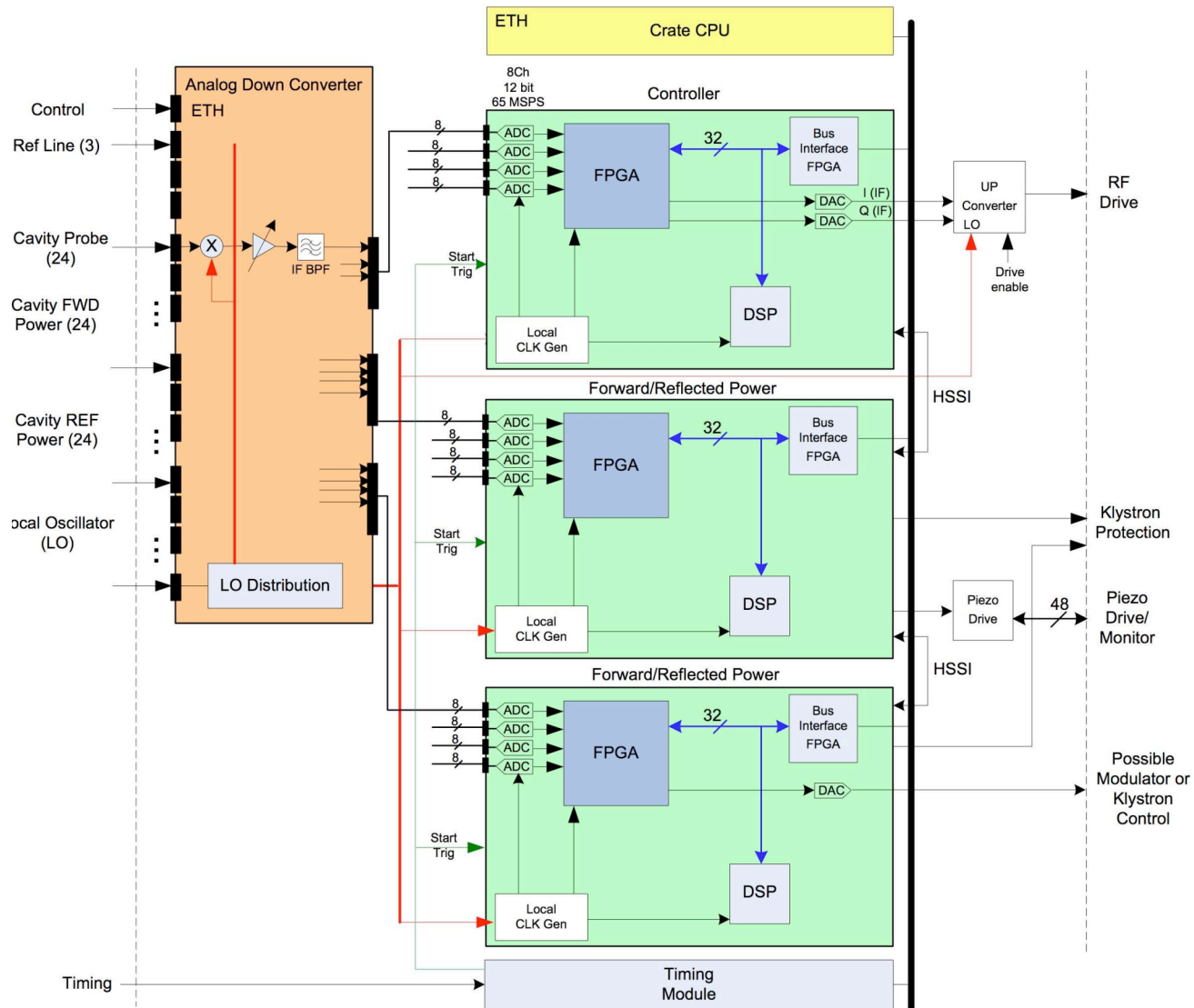



Receiver Section

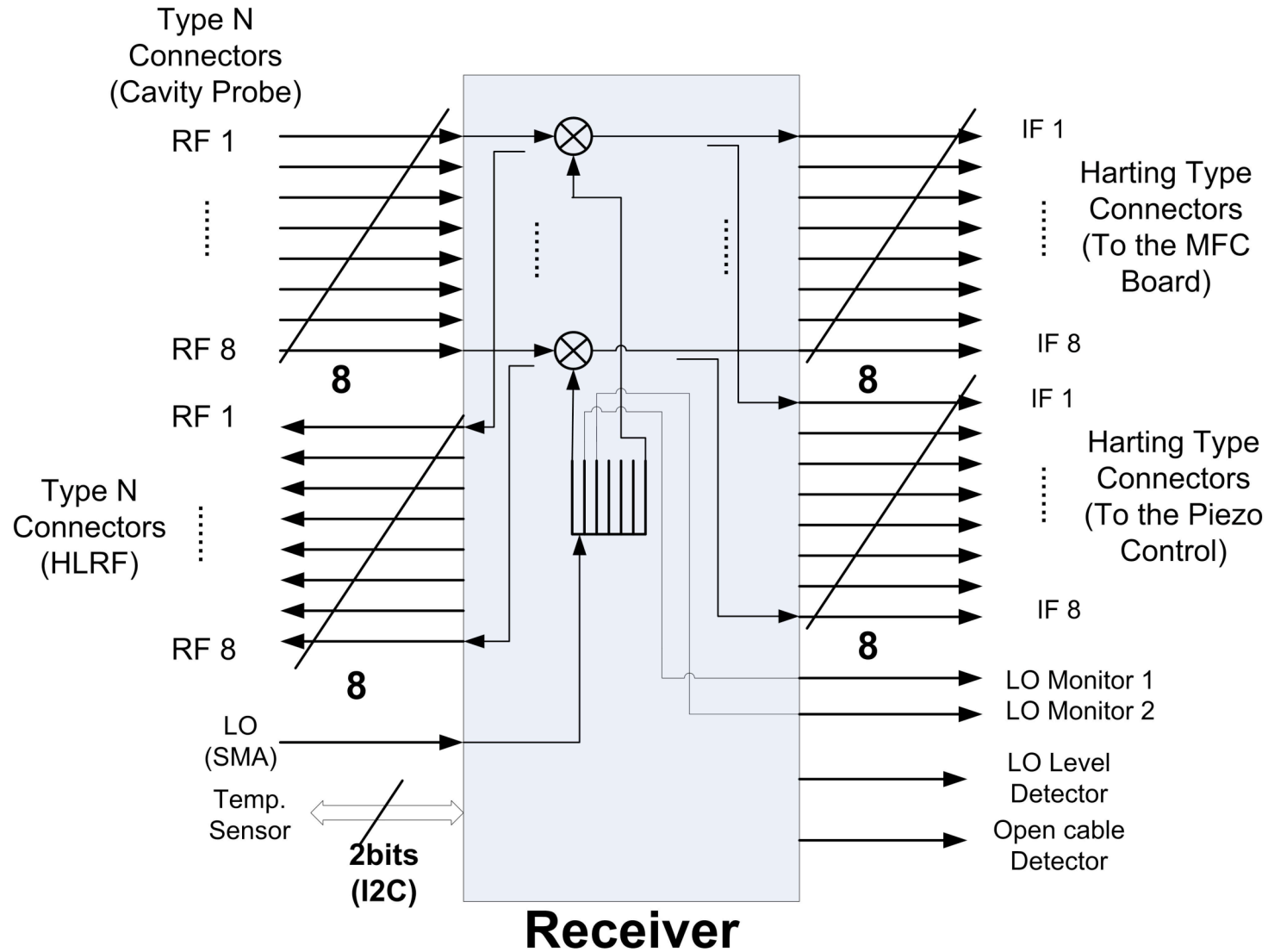



Receiver Data

MAIN PARAMETERS:

- Broad-band Noise (-157dBc/Hz - Simulated)
- Close-in Phase Noise ($3e-4^\circ$ - Measured)
- Nonlinearity (0.01dB-0.1dB - Simulated)
- Coupling (89dB - Measured)
- Temperature Stability ($0.1^\circ/\text{C}$ - Measured/Predicted)

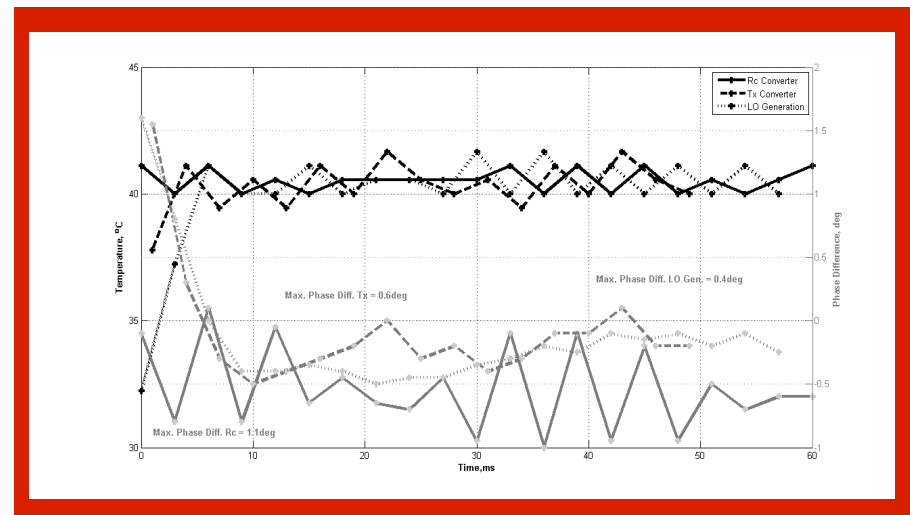
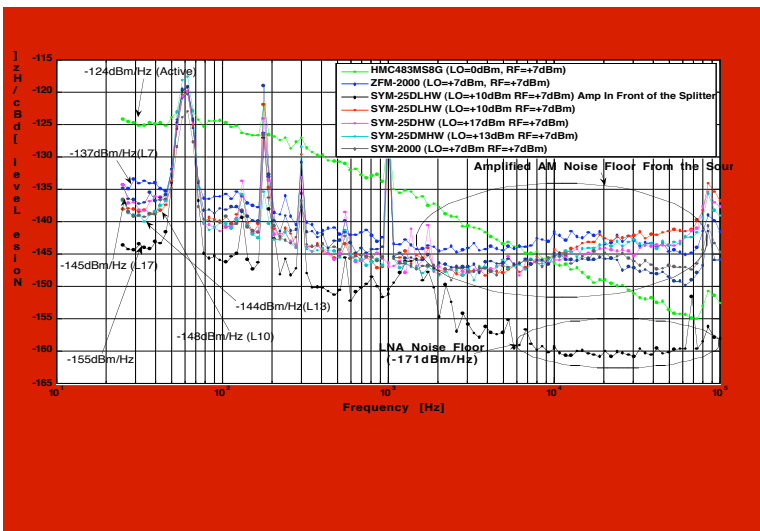



3 Cryomodule Field Controller

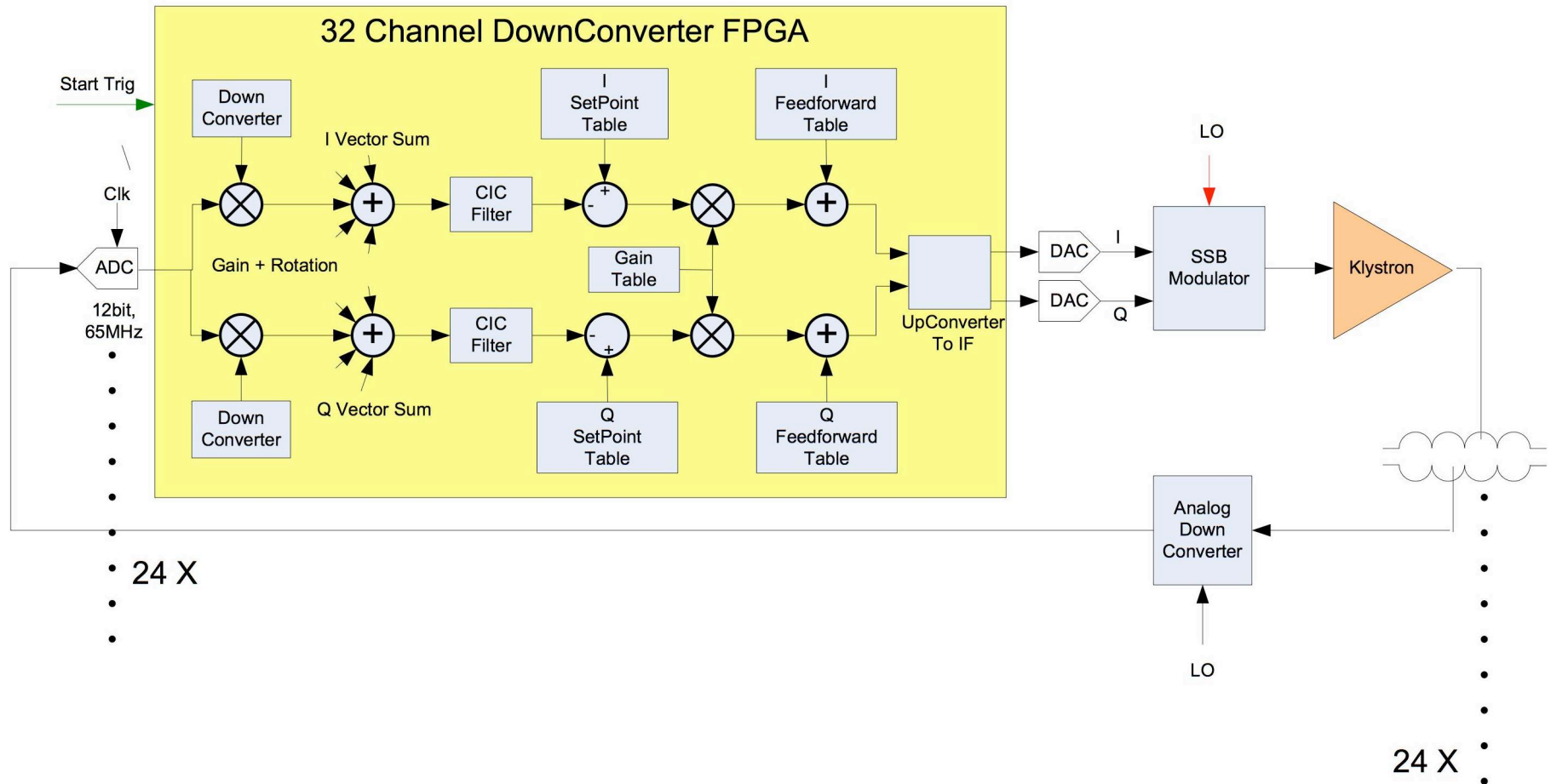



33 Channel MFC Board

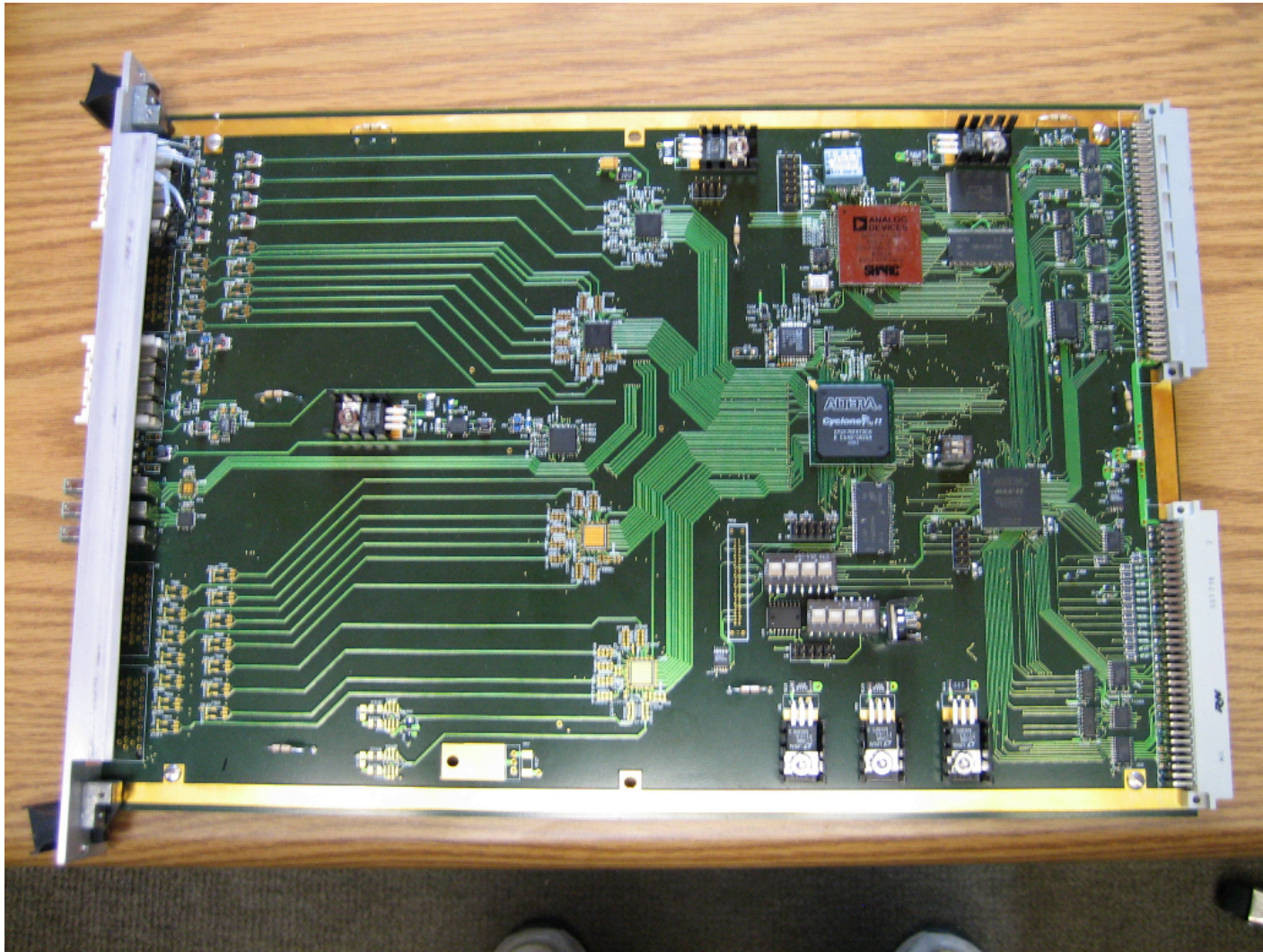



Receiver SNR Calculations

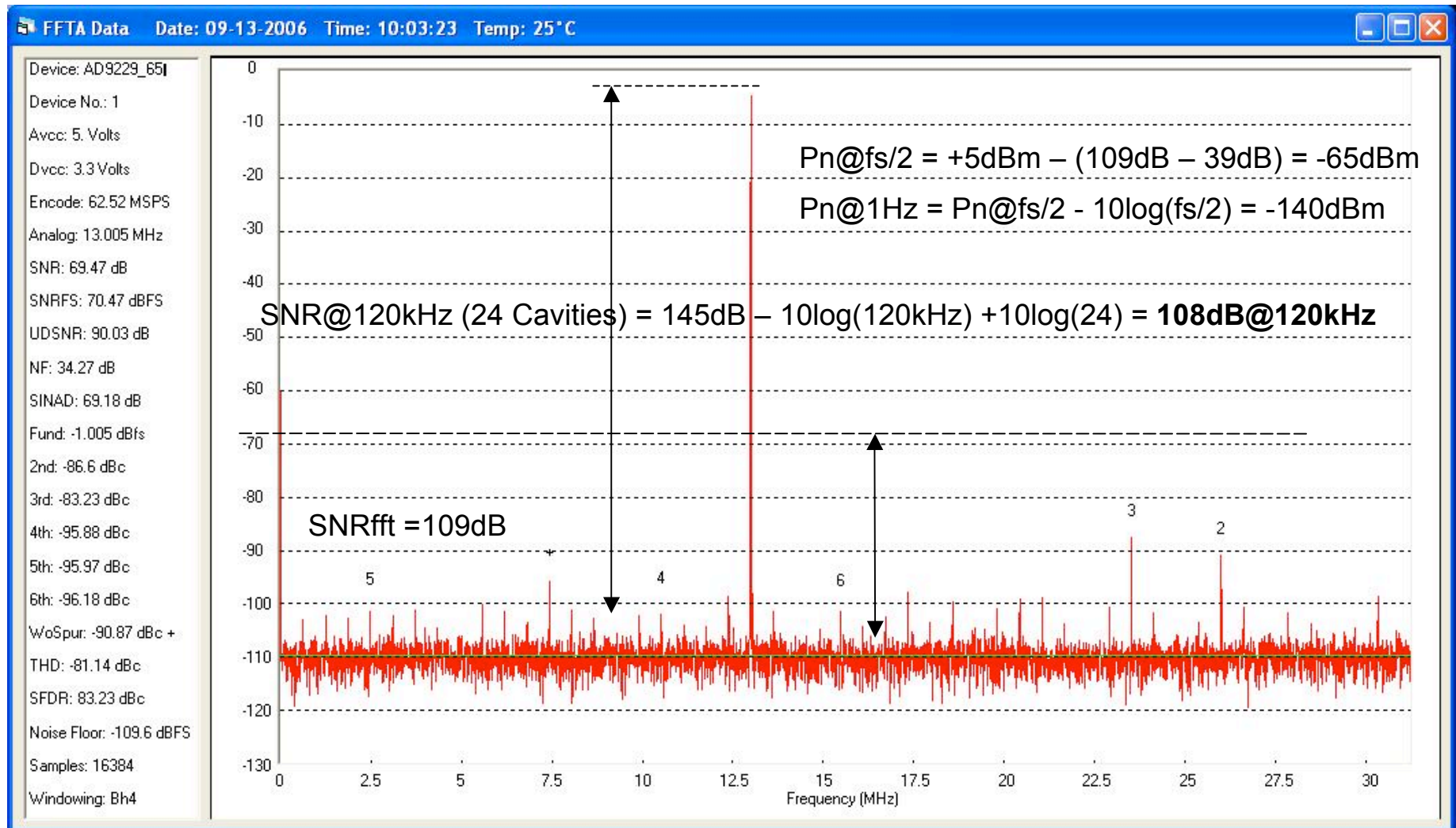



DESY SIMCON3.1 Controller

2.SIMCON3.1 board description and schematics.

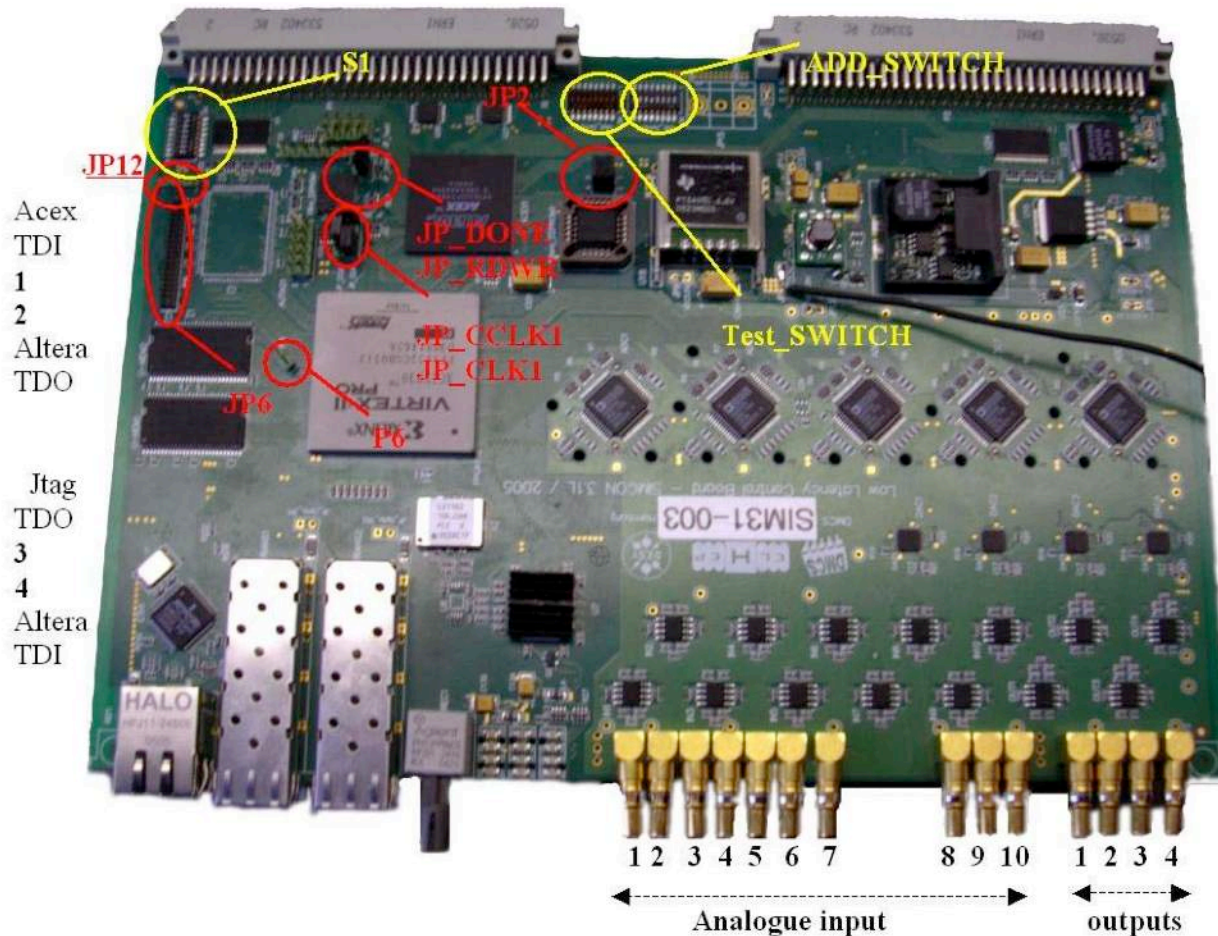



Phase Reference Chain

- Master Oscillator drives fiber reference(650,1300,3900MHz)
 - **Close in phase noise from MO is coherent across all systems and does not matter to first order**
 - **Relative phase is critical!**
- Local phase distribution repeats fiber signal without narrow band filters
 - **Filtering is done in the phase measurement process in the LLRF receiver**
 - **Narrow filters have problems with drift and microphonics**
- Narrow band PLL filtering is used in the generation of the LO which is phase locked to the reference RF
 - **LO noise will be driven to the cavities by the LLRF system**
- Absolute phase of the reference line relative to the LO is measured over 1 ms before the RF pulse
 - **Absolute phase in the LO is not important as long as it is stable over the time frame of phase measurement and the RF waveform ~ 5 ms.**



Active Phase Stabilized Link

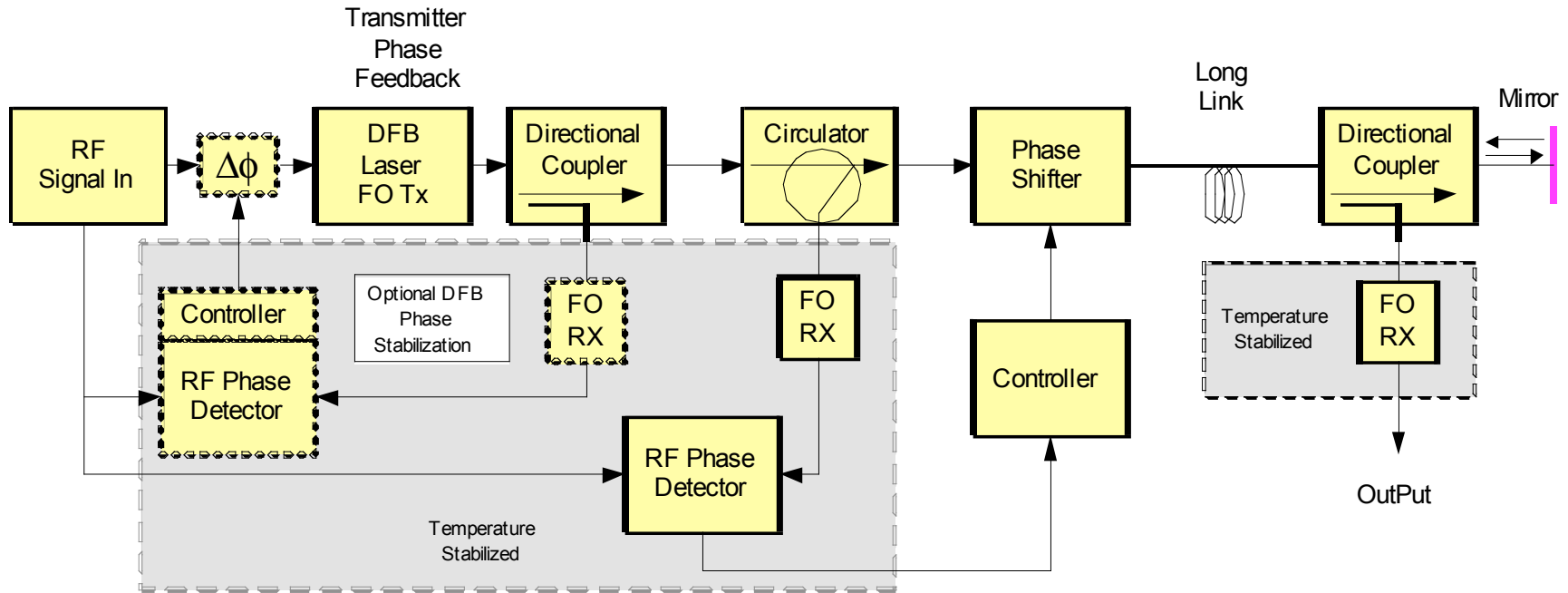

From Frank Lenkszus APS



Sector Timing Controller

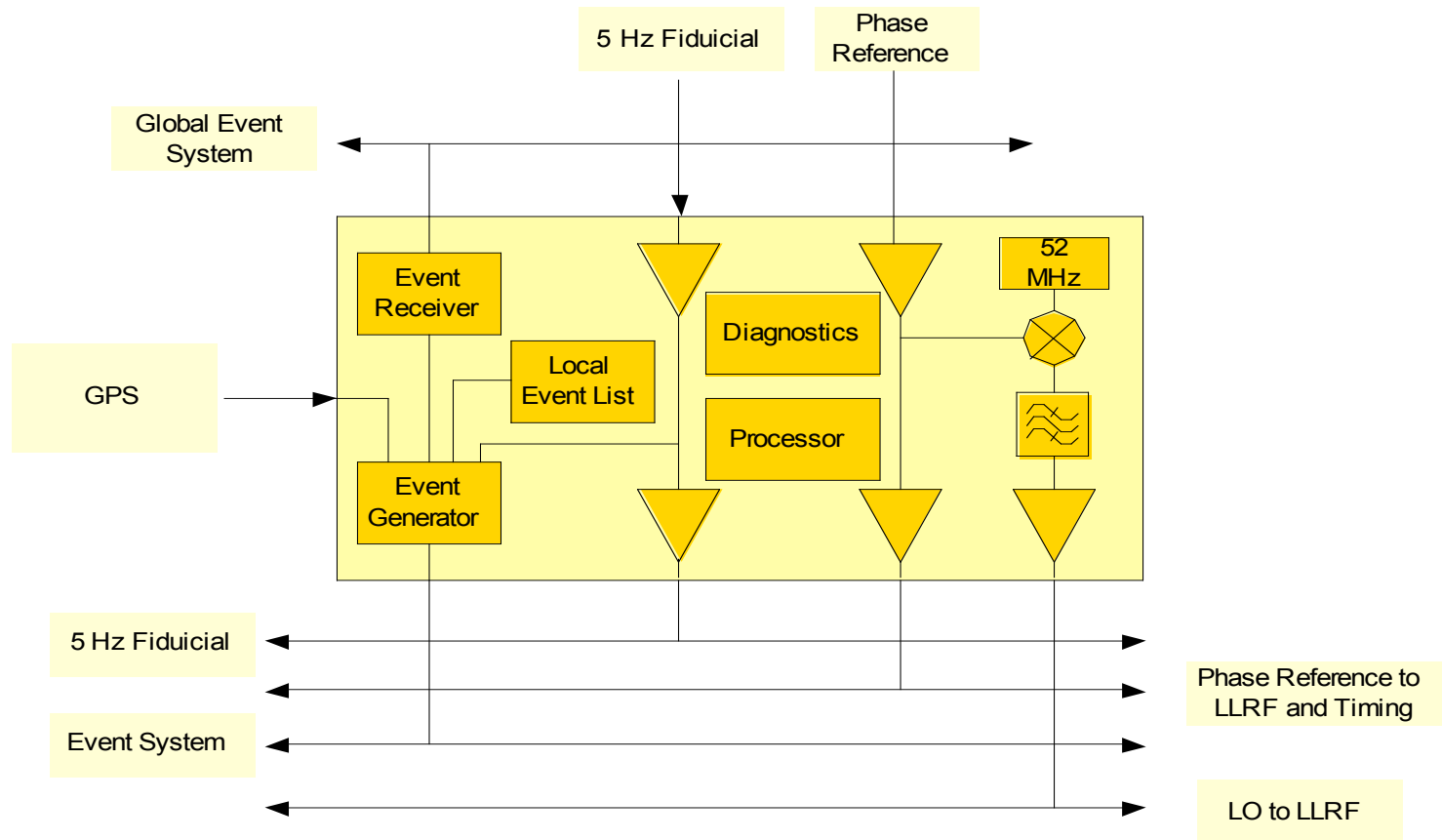

From Frank Lenkszus APS



CC2 Piezo Tuner

Calibrated “Bullet” Strain Gauge Sensor to measure preload changes during cooldown and stepping motor operation



CC2 Piezo assembly instrumentation:
- 11 strain gauges
- 2 RTDs

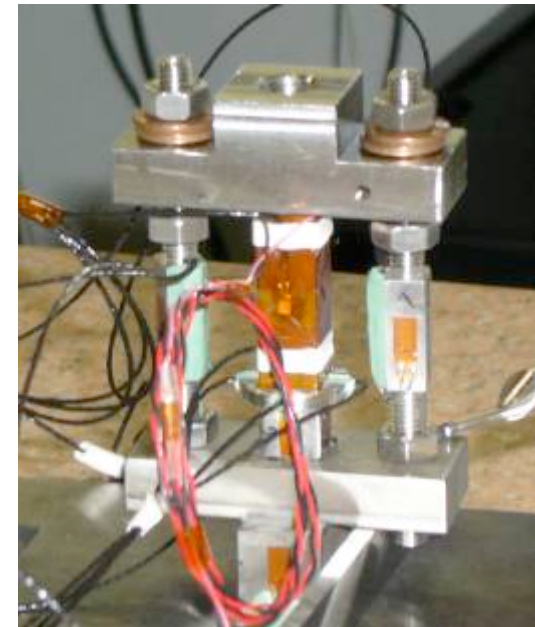



Piezo Test as a Vibration Sensor – CW mode

Piezo Tuner & RF Mixer Measurement of CC2 @10W CW Mode

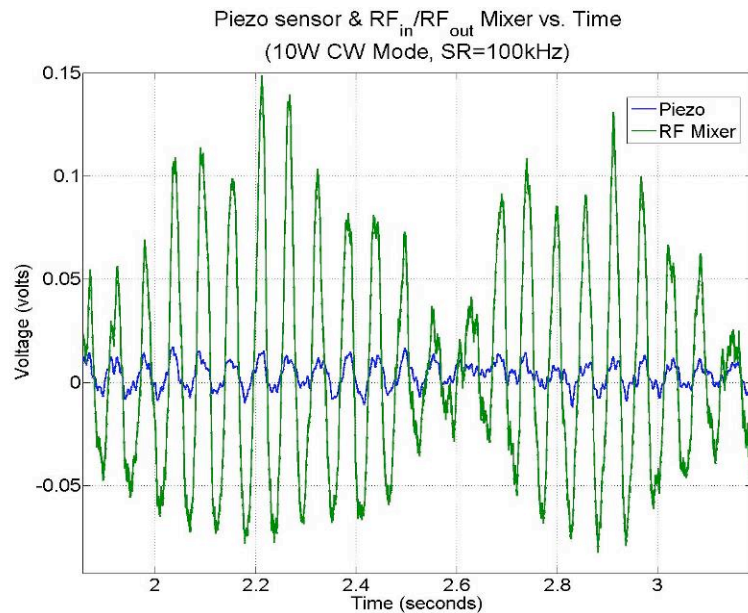

There is a good correlation between the Piezo Tuner and the RF Mixer in the time domain.

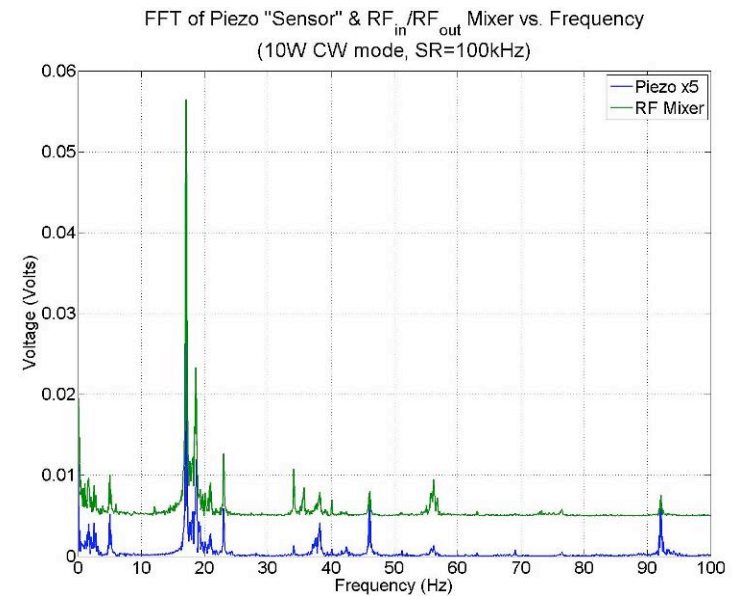

An FFT of the Piezo Tuner and the RF Mixer signals show close agreement in the frequency domain.



Real Time Cavity Simulator

Test run of ILC Cavity Simulator (no beam)

- 1) fill: 0 - 0.3 ms at 20 mA (full power)
- 2) flat-top: 0.3 - 1.1 ms at 12 mA
- 3) cavity emptying, decay curve shows high Q of cavity.

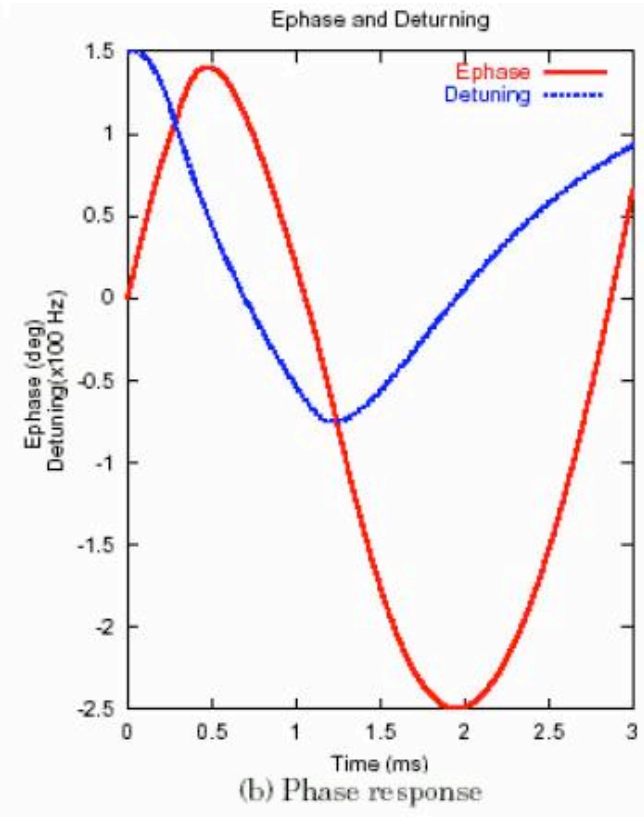
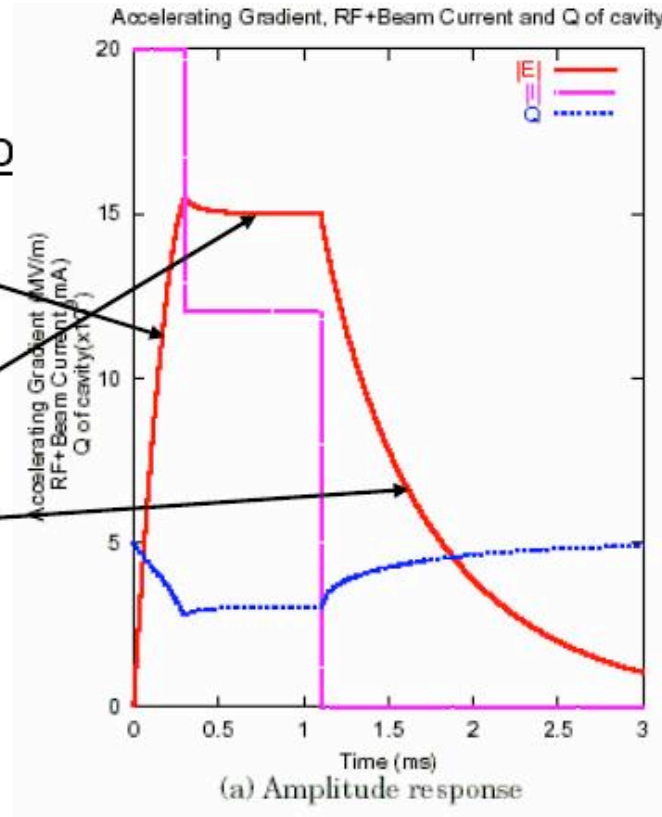

Compare with TESLA cavity measurements:
Shapes are similar, model is working.

IF in these simulations is 50 MHz.

Justin Keung, UPenn

FPGA & DSP boards @STF Phase1

Custom FPGA board
 : Mezzanine card of the commercial DSP board
 10 **16bit-ADCs** and 2DACs + 2Rocket IO
 40 MHz clock

Commercial DSP board (Barcelona)
 (same to J-PARC system)
 :4x TI C6701 DSPs
 Can access to FPGA like an external memory of DSP

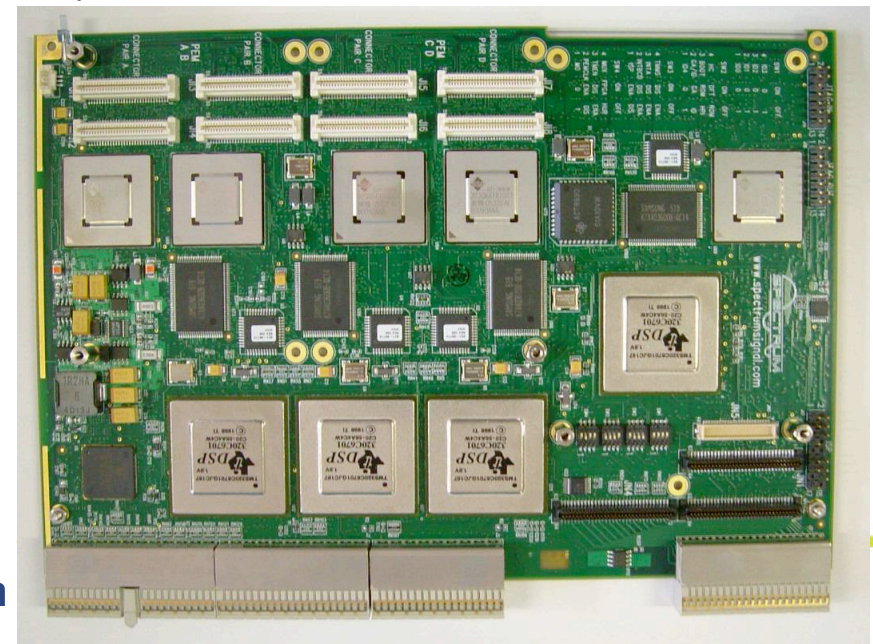
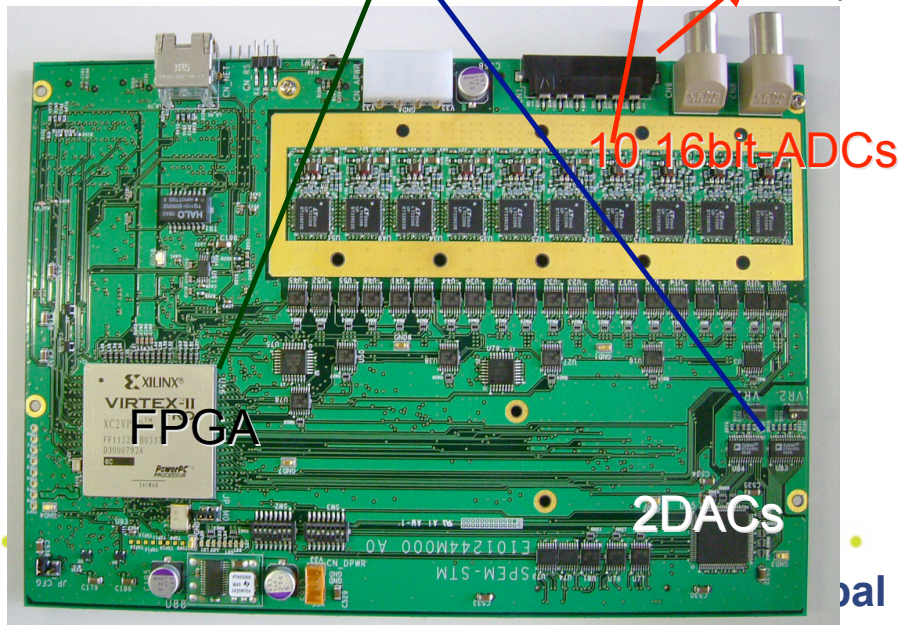
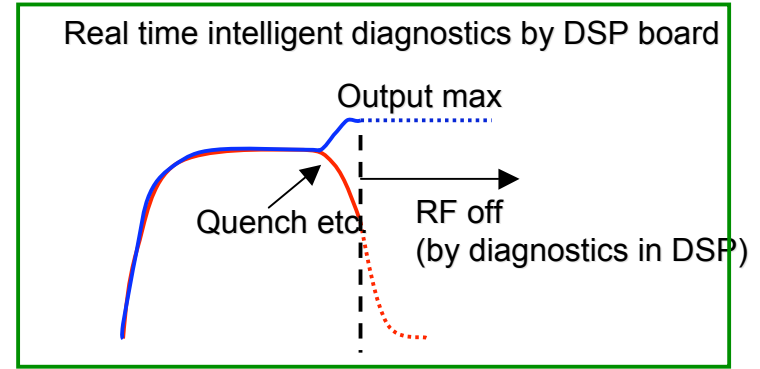
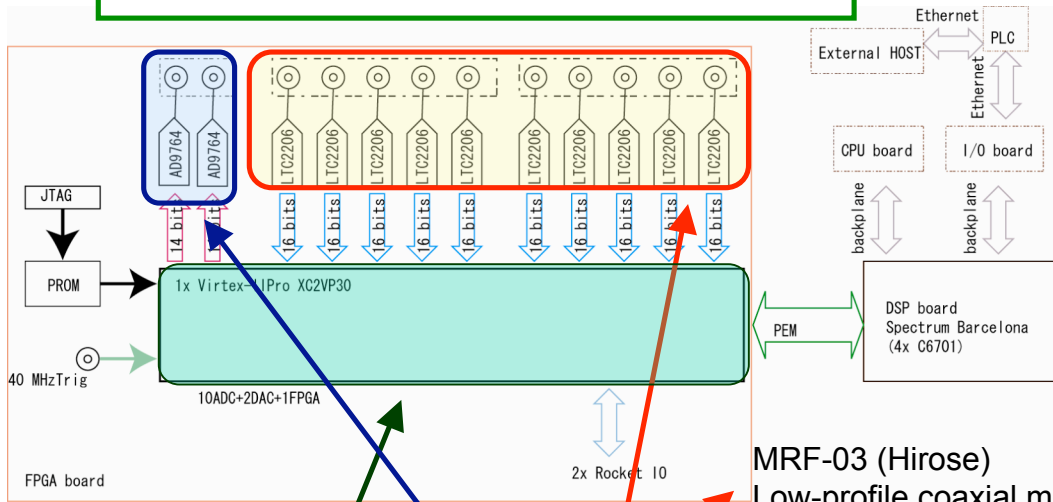



FB results with cavity simulators

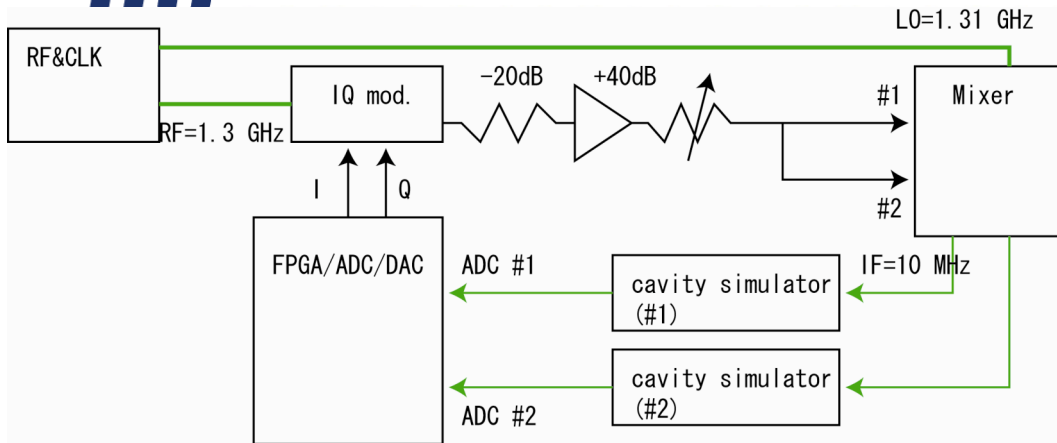

- Vector sum control with 2 cavity simulators
- LO: 1310 MHz
- IF: 10 MHz
- ADC/FPGA/DAC clock: 40 MHz

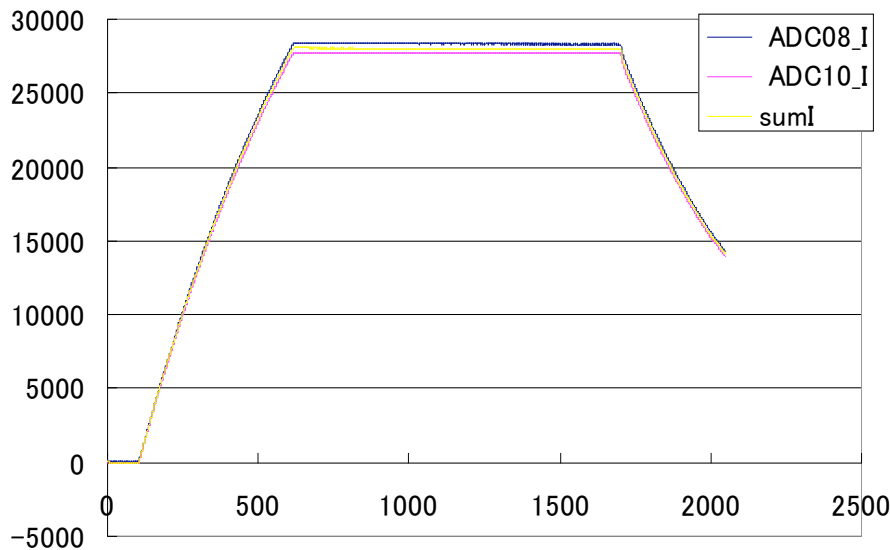

Amplitude and phase stabilities during FB with cavity simulators

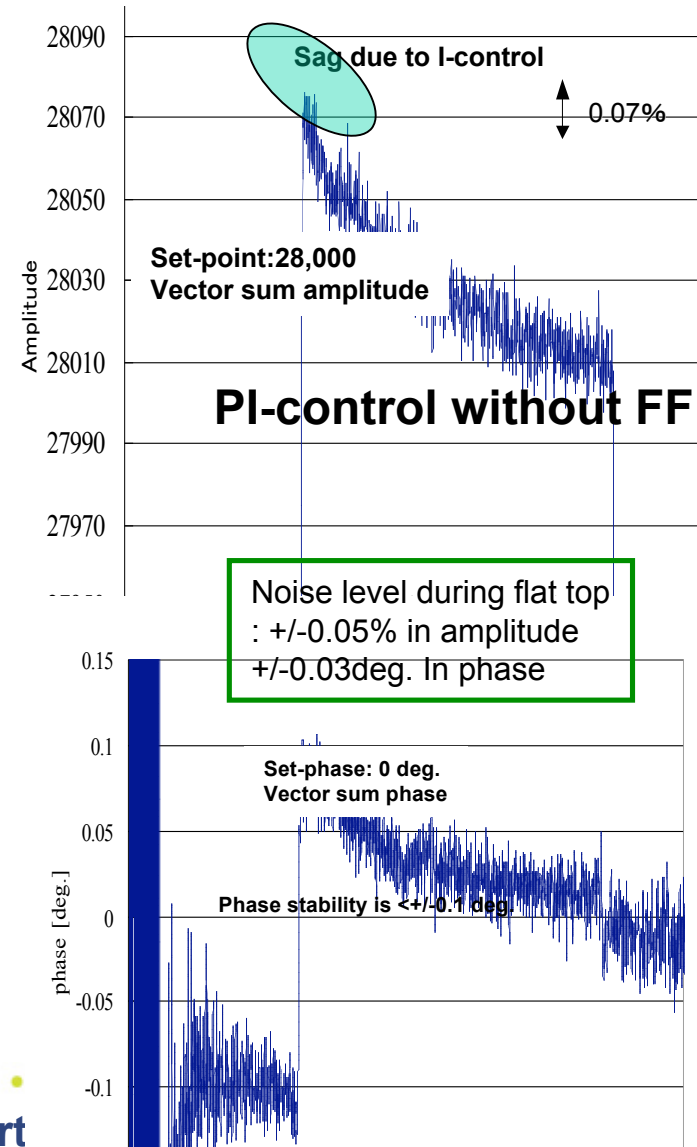

Effort



IF (intermediate frequency)-mixture

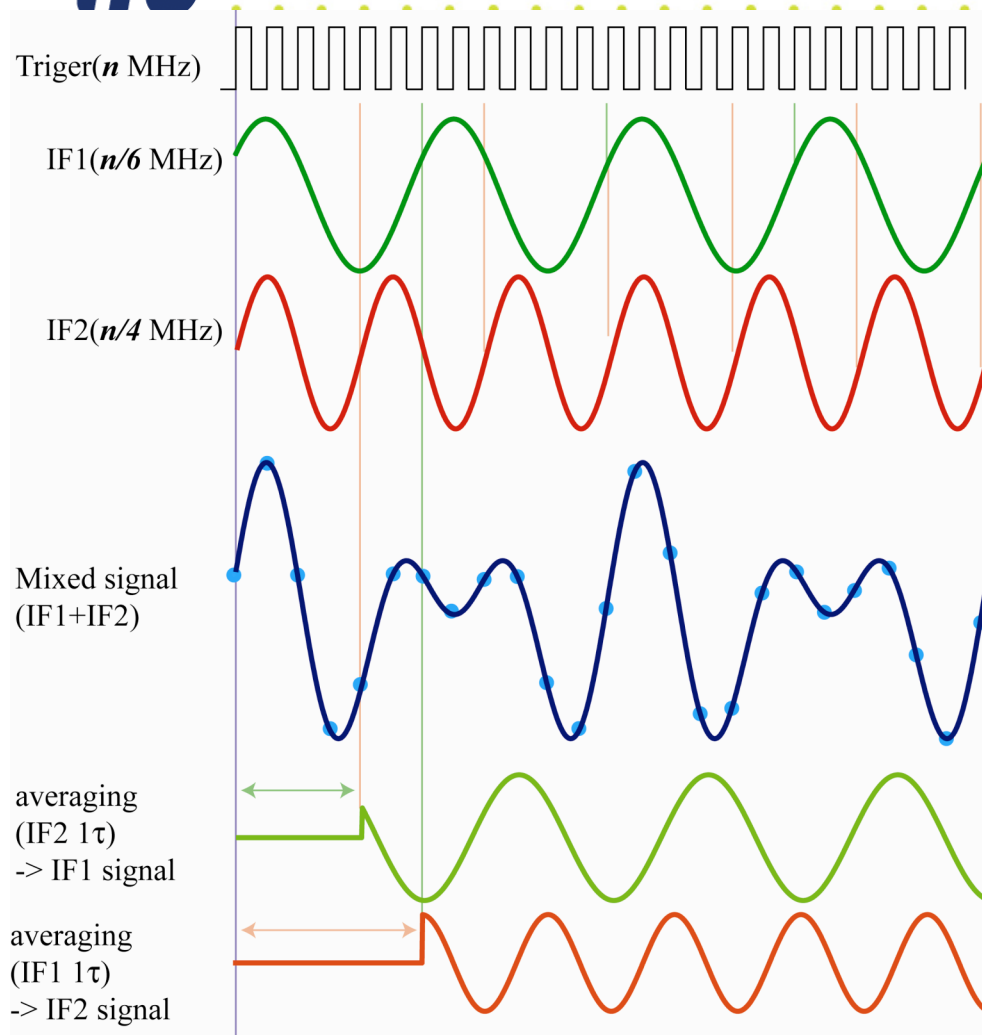

- Concept is like digital receiver
- Two IF are mixed in analog circuits.
- Two signals are separated at digital processing.

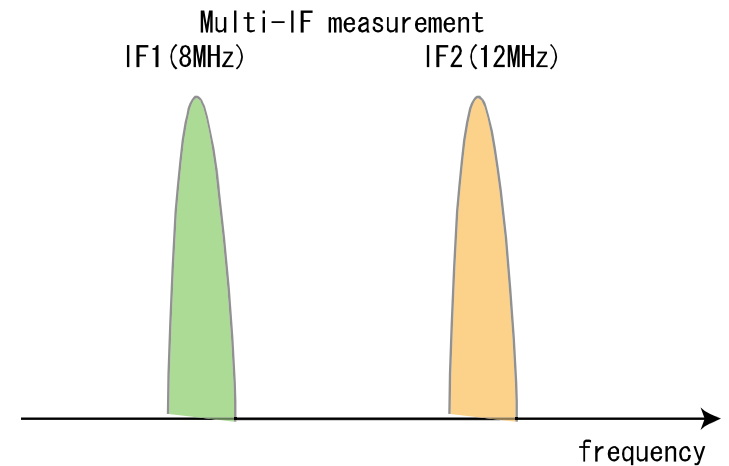



IF-mixture performance

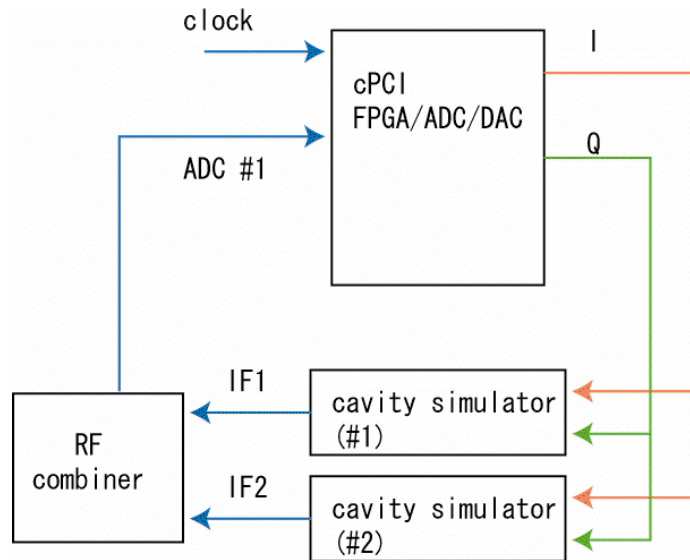

- Evaluation with two cavity simulators.
- Baseband analysis
- Simple algorithm to remove other IF by averaging.

Measured I/Q and amplitude/phase components with FB operation

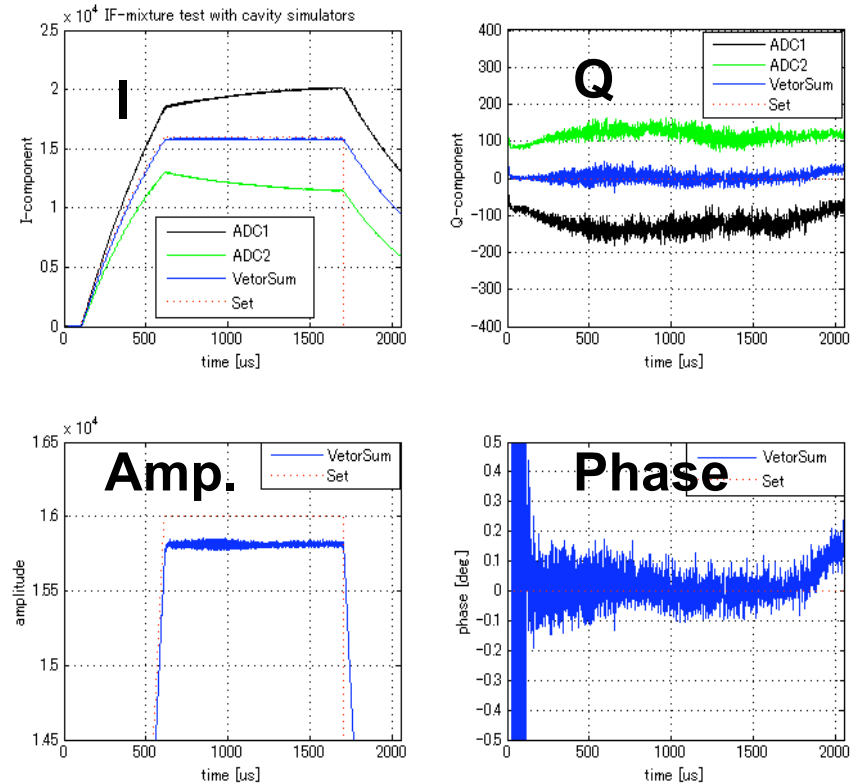

Amplitude error: 0.1% (RMS)
Phase error: 0.04° (RMS)



Automation

- Large number of stations require-
 - **System diagnostics must be mostly automated**
 - **Expert diagnostics must be carried out remotely through the control system**
 - **Error and fault detection and failure prediction**
 - Track klystron gain
 - **Self test**
 - On reboot and schedule
 - **Auto Calibration**
 - Built in “Network Analyzer” receiver calibration
 - Klystron linearizer calibration
 - Beam based cavity vector calibration



Software Modules

1. **Control Algorithms (Fdbck/ Feedforward)**
2. **Meas. QL and detuning**
3. **Cavity Frequency Control (Fast and Slow)**
4. **Amplitude/Phase Calibration**
5. **Vector-Sum Calibration**
6. **Loop phase and loop gain**
7. **Adaptive Feedforward**
8. **Exception Handling**
9. **Klystron Linearization**
10. **Lorentz Force Compensation**



LLRF Collaboration

- DESY, Warsaw ELHEP, KEK, FNAL(CD,AD,TD), LBL,SNS, SLAC, JLAB,University of Pennsylvania
- Weekly telecom for LLRF
- Weekly telecom for Controls
- Weekly telecom for HLRF
- Major design efforts underway for XFEL and test string at FNAL
 - **Several high performance controllers being developed**
 - **Master Oscillator and distribution**
 - **Real time Cavity Simulator**



Uncharted Waters(what looks tough)

- Large system scale
 - **All the issues of automation and getting it done right the first time**
 - **Phase reference and distribution over long paths**
- Identifying single point failures and adding redundancy where needed
 - **Example -LO and reference distribution**
- Vector sum calibration
 - **Accuracy - each system wide calibration will introduce a systematic error.**
- Beam based feedback
 - **Phase and energy at IP**
 - **Feedback to Crab Cavity vector control**



References

- “ILC Timing”, ILC-doc-158-V1, Lenkszus, APS
- “Status of the Penn C-based ILC Cavity Simulator”, Justin Keung, University of Pennsylvania
- “Recent Developments and Layout of the Master Laser System for the VUV-FEL”, A. Winter, F. Ö. Ilday, H. Schlarb, F. X. Kaertner, DESY Hamburg, Bilkent University, MIT 16.05.2006
- “Digital Low-Level RF Control for Future Superconducting Linear Colliders”, S. Simrock, PAC 2005
- “Achieving Phase and Amplitude Stability in Pulsed Superconducting Cavities”, S. Simrock, PAC 2001
- “LLRF of Low Level RF System for the J-PARC LINAC”. S. Michizono, LINAC 2004