

# Design status 2 mrad IR

*Current plan for finalization in 2008*

Philip Bambade  
LAL-Orsay

On behalf of:

D.Angal-Kalinin, R.Appleby, F.Jackson, D.Toprek (Cockcroft)  
P.B., S.Cavalier, O.Dadoun, M.Lacroix (LAL-Orsay)

IN2P3-KEK collaboration meeting,  
Annecy, October 15-17, 2007

# Outline

- Motivations
- Status of “minimal” redesign
- Current plans and aims
- Concluding remarks

.....

Alternative IP luminometry & polarimetry idea ?

# Motivations for 2 mrad

- Large crossing-angle :
    1. Eases post-IP beam extraction & transport → diagnostics
    2. But adds pre-IP constraints : crab-cavity control & tuning, non-axial solenoid + DID / anti-DID → pre / post-IP trajectory bumps
  - Physics & detector advantaged by small crossing-angle IR : simpler forward geometries, better hermeticity, no DID / anti-DID
  - Head-on IR a priori nicest → needs large electrostatic separators
  - **2 mrad scheme** : no crab-cavity (initially...), no electrostatic separators and order-of-magnitude smaller pre / post-IP trajectory bumps
  - Snowmass 2 mrad design **unsatisfactory** → redesign with simpler concept aiming to be as short & economical as possible
  - **Assumption** : other ways than the present spent-beam spectrometry & polarimetry possible if planned pre-IP measurements need complementing
- **Minimise costs and mitigate technical risks**

# New “minimal” extraction line concept

→ Explicit goals : short & economical, as few and feasible magnets as possible, more tolerant and flexible

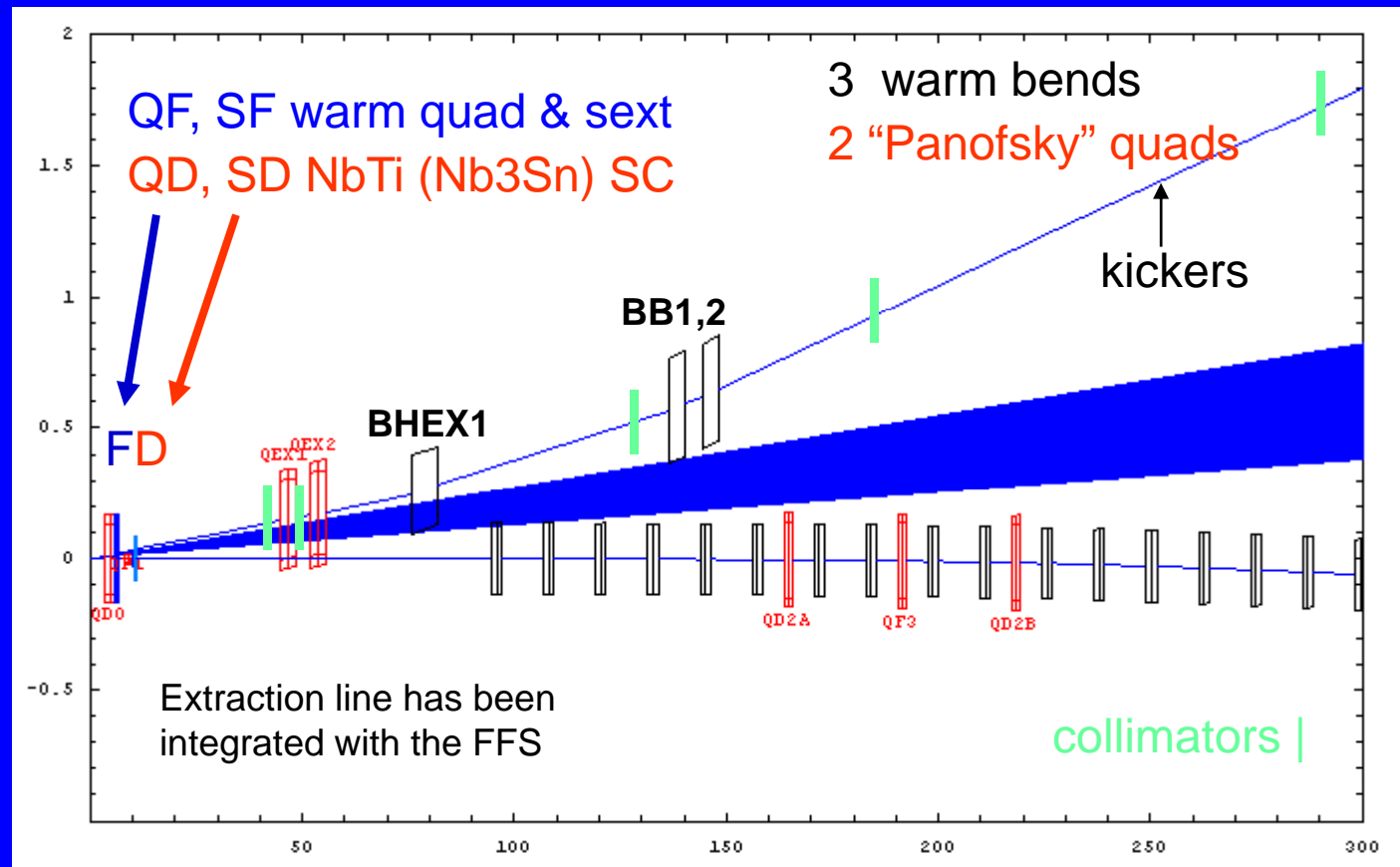

dump(s):  
0.5 m  
flexible  
3 m

Beam rastering kickers can be placed to prevent water boiling and window damage

Length ~ 300 m

# Optimised compact final doublets

- Re-designed with acceptable losses and stay-clear for in / out charged & beamstrahlung beams → EUROTeV-Memo-2007-001 & JINST 1 P10005 (2006)
- Works for all proposed ILC beam parameter sets, including (new) “High Luminosity” at 1 TeV (GP++ large statistics at <http://ilc-mdi.lal.in2p3.fr/spip.php?rubrique17>)
- Compact SC QD,SD : NbTi LHC-like QD at 500 GeV, Nb3Sn SLHC-like QD at 1 TeV, NbTi 60 mm radius SD
- Standard warm QF & SF, with 20 and 30 mm radius
- Outgoing beam subject to non-linear pocket fields of QF1 and SF1

Table 1: The 500 GeV final doublet parameters.

Parameter	QD0	SD0	QF1	SF1
Length [m]	1.059	1.469	1.596	0.75
Strength	$-0.270 \text{ m}^{-2}$	$2.969 \text{ m}^{-3}$	$0.0786 \text{ m}^{-2}$	$-2.044 \text{ m}^{-3}$
radial aperture [mm]	28	60	20	30
gradient [T/m]	225	-	65	-

Table 4: The 1 TeV final doublet parameters.

Parameter	QD0	SD0	QF1	SF1
Length [m]	1.352	2.5	3.192	1.5
Strength	$-0.210 \text{ m}^{-2}$	$1.502 \text{ m}^{-3}$	$0.0394 \text{ m}^{-2}$	$-0.943 \text{ m}^{-3}$
radial aperture [mm]	25	59	20	30
gradient [T/m]	350	-	66	-

Parameter set	QD0	SD0
High Luminosity CB [W] 500 GeV	<1	<1
High Luminosity RB [W] 500 GeV	0.46	0.2
High Luminosity CB [W] 1 TeV	<1	<1
High Luminosity RB [W] 1 TeV	0.82	0.04

## Losses in SC magnets [W]

	500 GeV	1 TeV
$l^*$ [m]	4.5	4.5
QD0-SD0 [m]	0.8	0.8
SD0-QF1 [m]	3.03	2.05
QF1-SF1 [m]	0.5	0.5

## 2 mrad beampipe layout in IR region

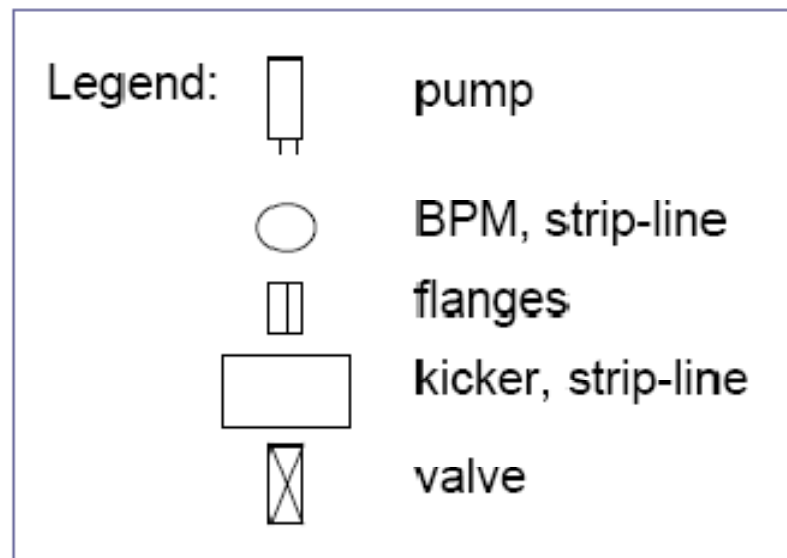
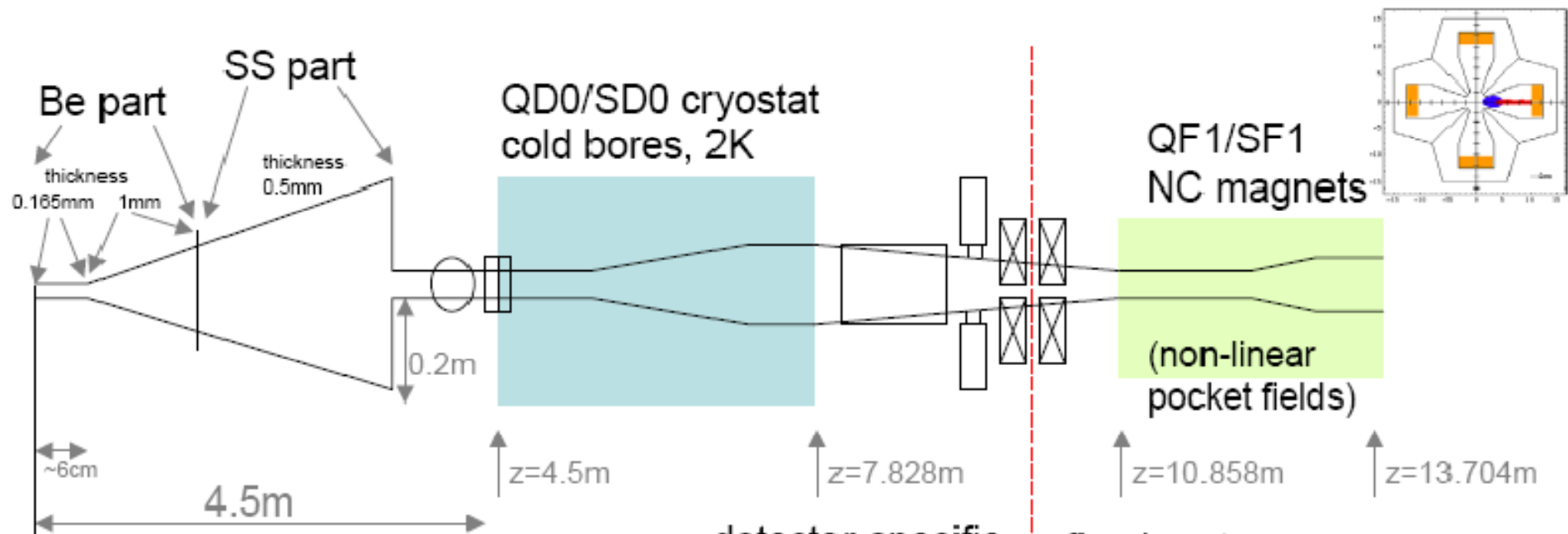

detector-specific part

fixed part

z=~-9.5m

Tapering apertures between shared beamline elements

Breakpoint between SD0 and QF1

No FD cryostat needed for QF1/SF1

QD0/SD0 outer sizes, cryostat design/size, support for integration and detector opening procedure ?

# Variable $I^*$ IR layout

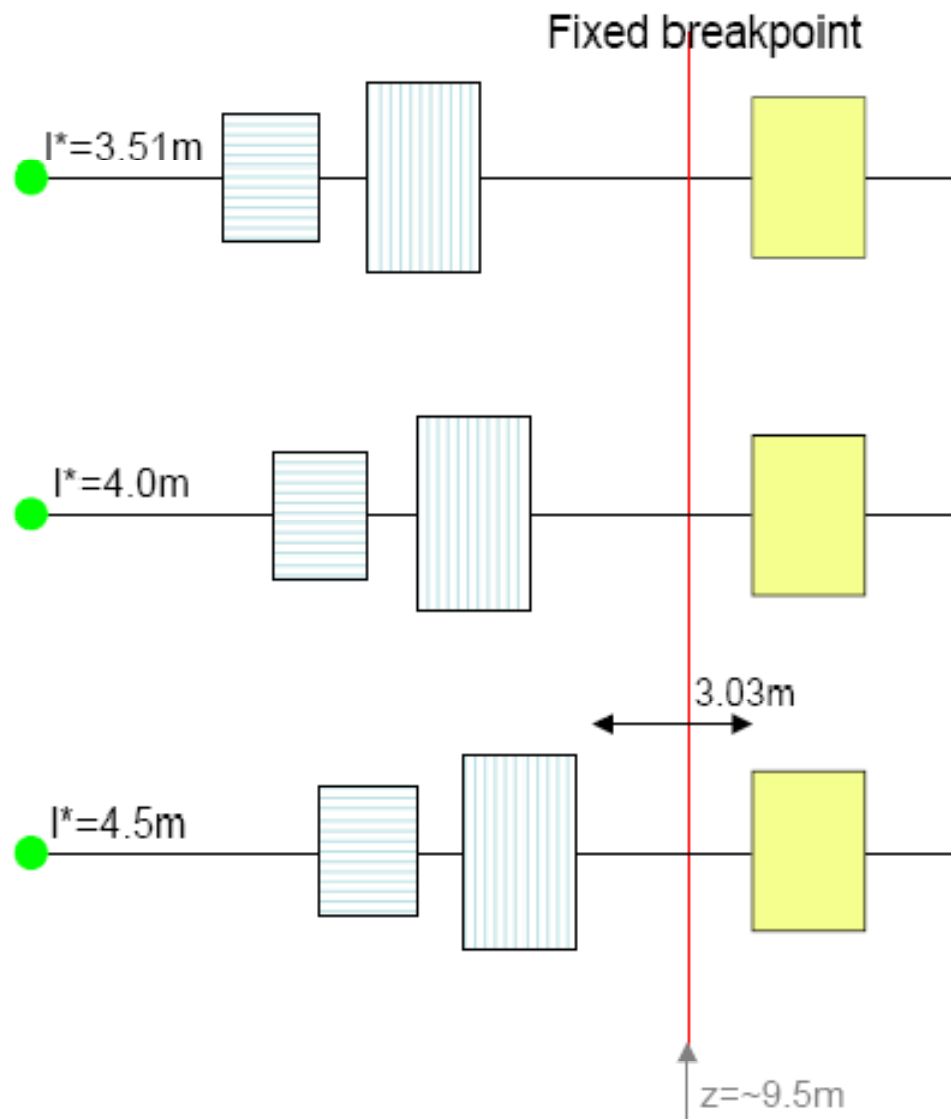

Optics design exist for  $I^* = 4.5\text{m}$ .  
Variable  $I^*$  achieved by

- Fixed breakpoint located between SD0 and QF1
- Optics refitted by varying SD0-QF1 distance to obtain sufficient beam separation and minimum losses
- Some impact on beam power losses and beam separation

Keep physical size of FD magnet constant (change currents)

Variable  $I^*$  of detector gives varying downstream orbit. Correct using corrector dipoles

Key:  QD0  SD0  QF1  IP

First thoughts → needs to be worked out in detail

# First look at beam pipe in FD region

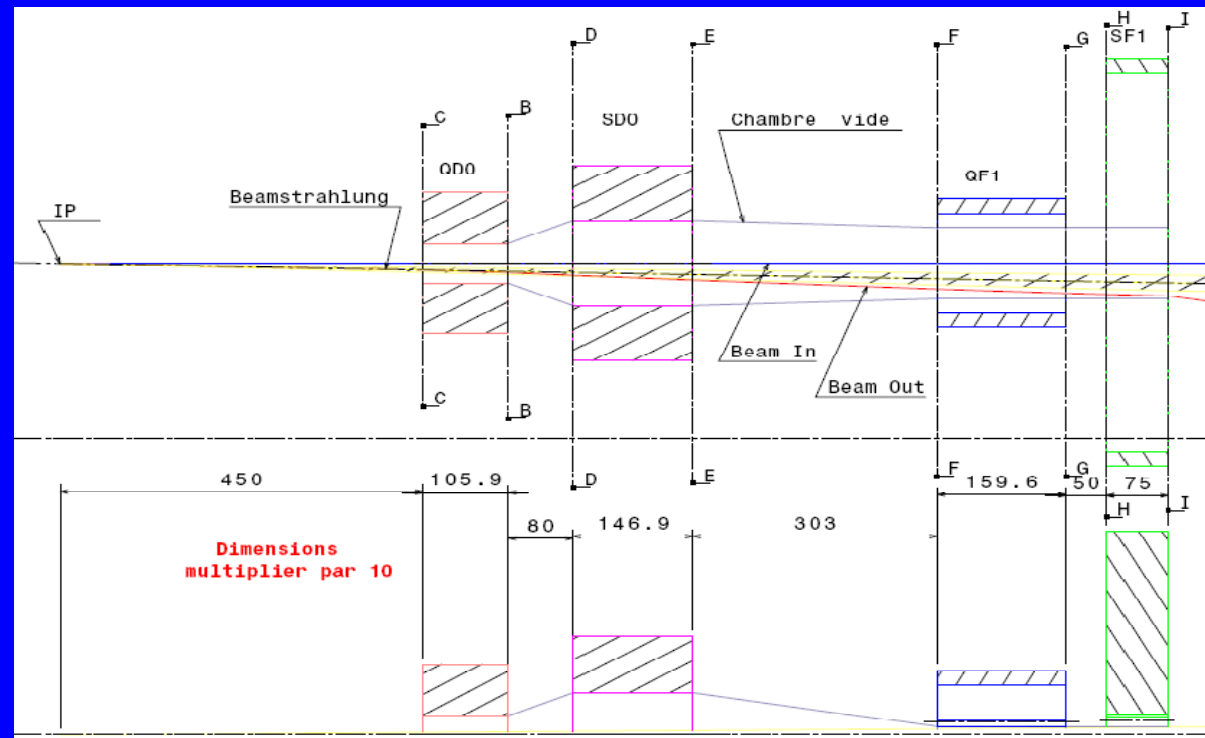
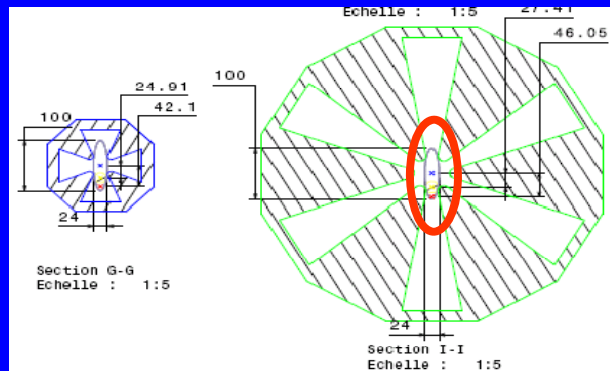
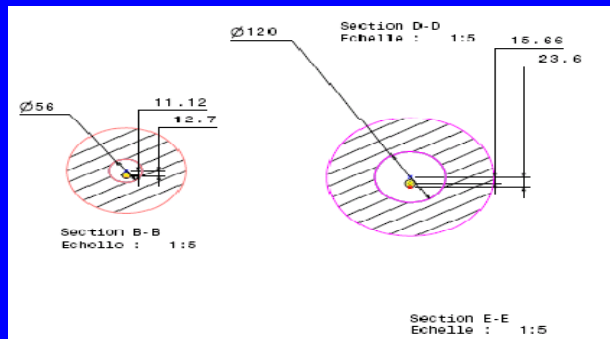

Next :

- Separating the incoming beam and designing the shared region up to QEX1,2 (40 m) and BHEX1 (80 m) for the outgoing and beamstrahlung beams
- Separation of beamstrahlung after BHEX1
- Analyze direct lines of sights to VD through BeamCal mask hole ( $r = 1.2$  cm)



# Magnets and collimators in rest of line

- Designed proof-of-principle optics with reasonable QEX1,2, BHEX1 and BB1,2 apertures & strengths and acceptable losses on dedicated collimators at both 500 GeV and 1 TeV → [EUROTeV-Memo-2007-004](#)
- Can be adjusted depending on best choice of dump arrangement
- Flexibility : magnet + beam pipe designs → final parameters

Magnet	Length	Strength/angle	Radial aperture [mm]	B [T]
QEX1	3.0	0.011 /m	116	1.04
QEX2	3.0	0.0056 /m	138	0.63
BHEX1	8.0	2.0 mrad	-	0.21
BB1	8.0	2.0 mrad	-	0.21
BB2	8.0	2.0 mrad	-	0.21

worst case maximum : high luminosity parameters with vertical offset

Collimator name	Position [m]	Length	Power load [kW]	X jaw [mm]	Material	Cooling
QEX1COLL	38.75	1.0	15	104	Cu	Radiative
QEX2COLL	45.75	1.0	15	95	Cu	Radiative
COLL1	150	2.5	205	116	Al (balls)	Active
COLL2	200	2.5	205	204	Al (balls)	Active

# Vertex detector backscattered photon hits from extraction line losses

- BDSIM model of extraction line constructed to assess photon flux towards VD from charged beam losses on the main extraction line collimators
- MOKKA model of the LDC detector to compute hit probability in VD  $\rightarrow \sim 2.2\%$

	D [m]	X [cm]	P [kW]	# $\gamma$ 's/bx	VD hits / BX
QEX1COLL	45	20	0.2	1.3	0.02
QE2COLL	53	-	0	0	0
BHEX1COLL	76	41	0.1	0.2	0.004
COLL1	131	85	52.3	40	0.8
COLL2	183	115	207.5	82	1.8
COLL3	286	-	0	0	0

(nominal beam parameters)

Conclusion : VD hits negligible from this contribution compared to rate from incoherent beam-beam pairs  $\sim 250$  hits / BX

**Notes:**  $\gamma$ 's reach VD layers via direct lines-of-sight from Cu collimator, passing through BeamCal hole with radius 12 mm, assuming no reflections on beam pipe

# BHEX1 C-type bend

Accommodates the beamstrahlung, outgoing beam and proximity of incoming beam

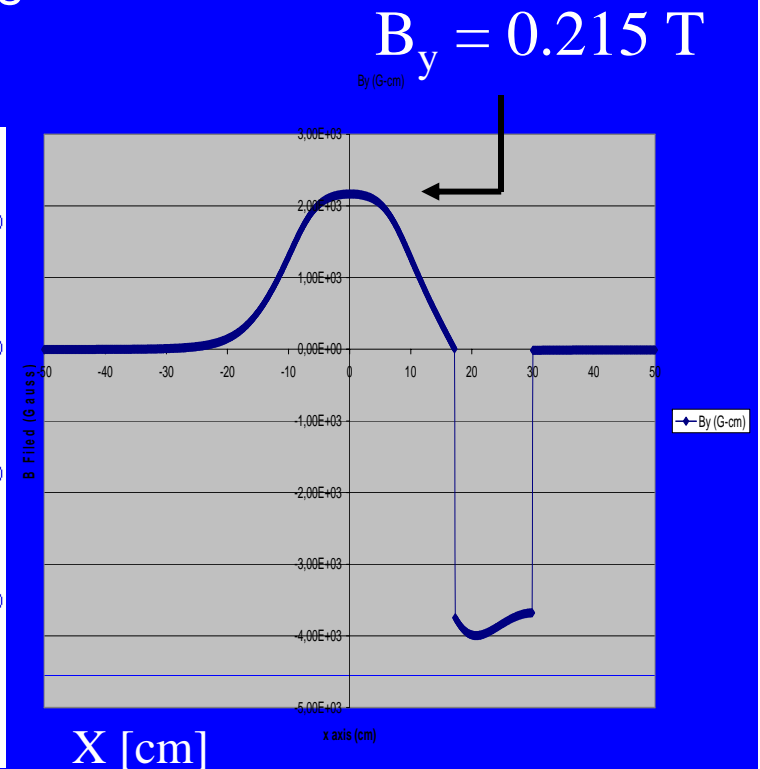
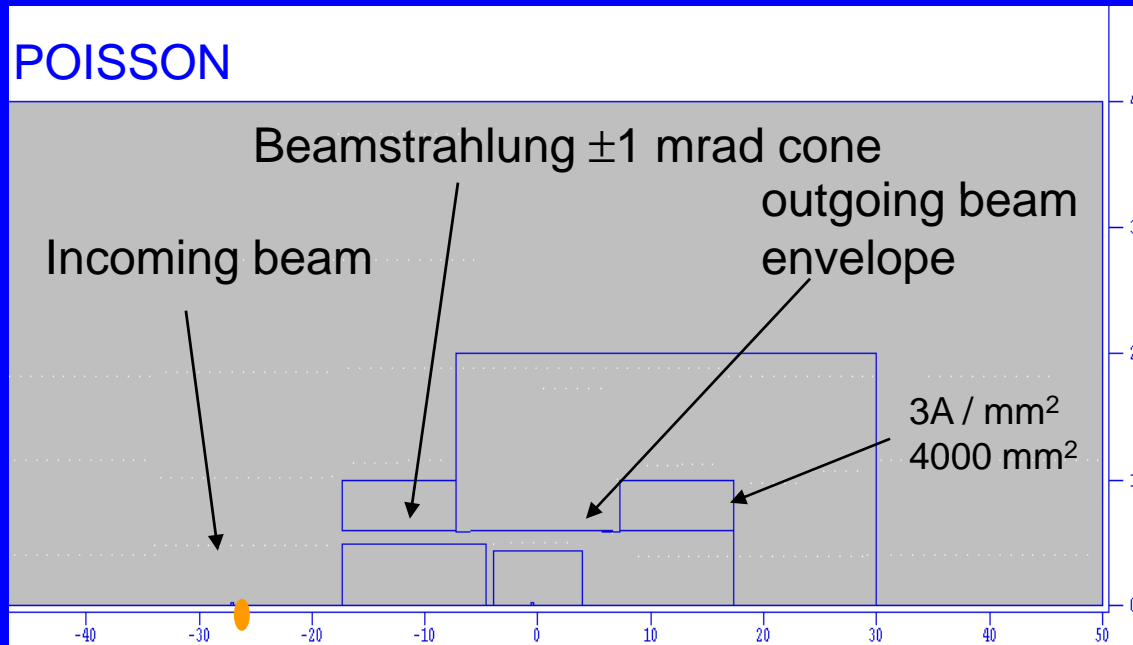

- $B_y(x)$  homogeneity  $< 4\%$  (with shims) within outgoing beam envelope  
→ checked to be sufficient
- Residual  $B_y$  on incoming beam  $\sim 1\% \rightarrow 20 \mu\text{rad}$  ( $7.5 \sigma_x$ ) → use corrector
- Residual  $B_x(y)$  dependence on incoming beam → only even powers  
sextupole absorbed refitting SD / SF, decapole → negligible effects

# Bandwidth from BEX1 decapole component

Comparison done with ILC final focus optics integrating FD of 2 mrad scheme

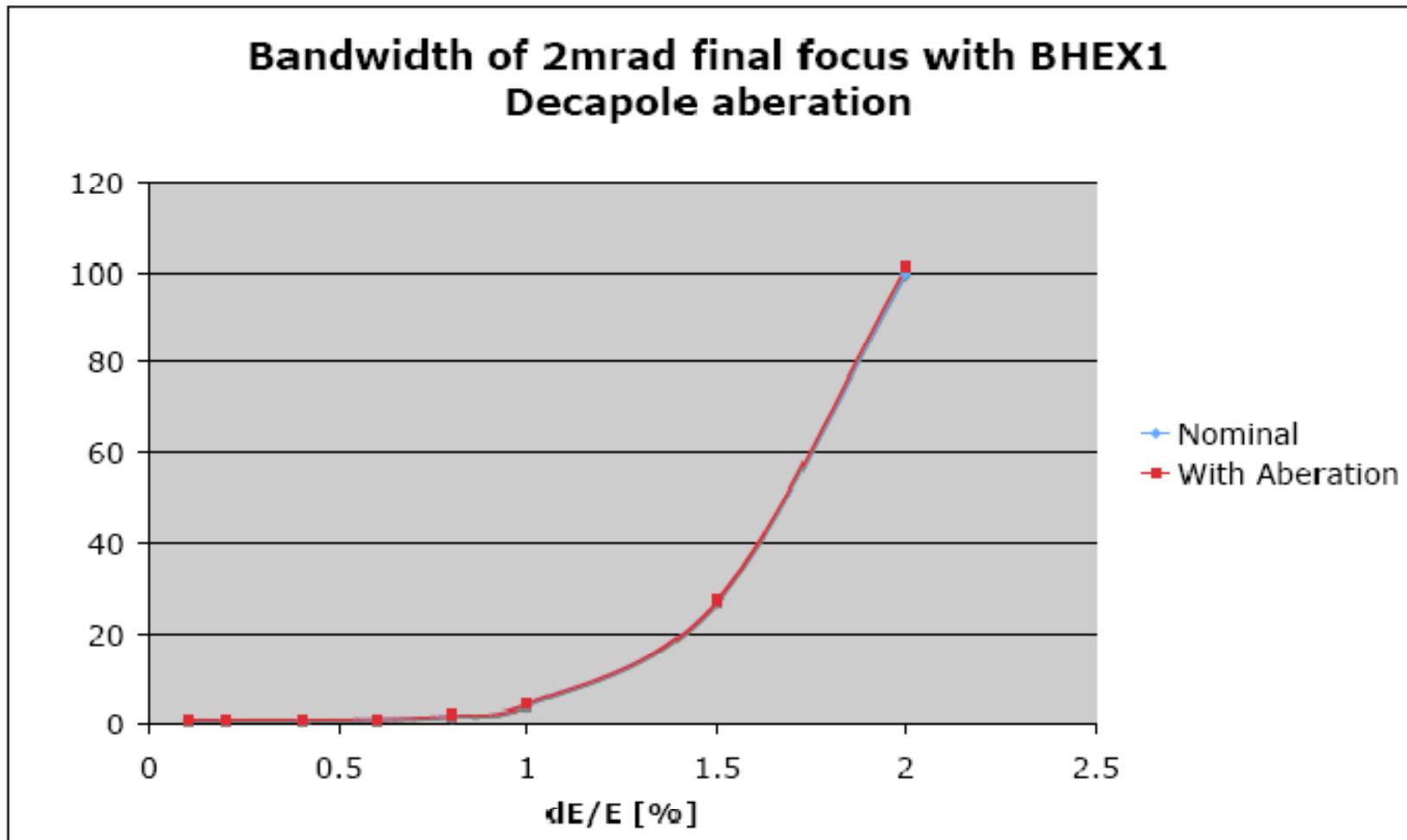

# Further engineering for final design and costing

- QF, SF & BB1,2 “standard” magnets

LAL & Cockcroft + experienced warm magnet group

- “Panofsky” – style large aperture quads

L. Hand & W. Panofsky, Review of Scientific Instruments  
Vol. 30, No. 10, 927-930, 1959

Experienced warm magnet group + LAL & Cockcroft

- NbTi SC QD & large bore SF for 500 GeV CM

R&D → Nb<sub>3</sub>Sn SC QD for 1 TeV upgrade

SC magnet group: LBL & FNAL ? + LAL & Cockcroft

- Investigate detector integration and push-pull scenarios

LAL & Cockcroft together with existing team on baseline

- Not considered in detail so far : dump and collimators

→ should connect to baseline work on these

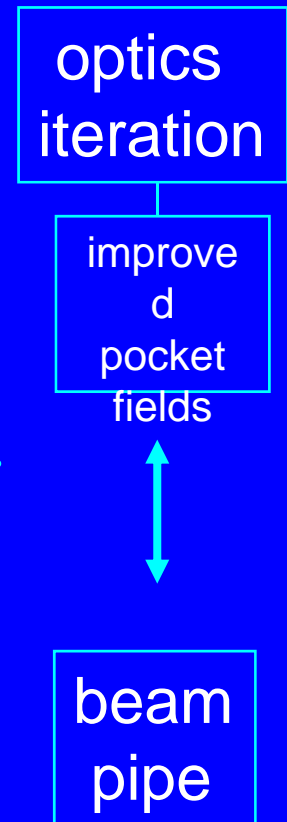

---

# EDR plans

Aim of proposed EDR-phase 2 mrad tasks is to bring the design to the level of a credible alternative to the 14mrad baseline

- **Optics and beam transport**
  - variable I\* IR and extraction line layout (CI)
  - further study of extraction line aberrations on final focus beam(CI, LAL)
  - iteration of design and losses as magnet designs progress (LAL, CI)
  - iteration of integration of 2 mrad FD in final focus optics (CI)
- **Magnet design studies**
  - design of large aperture final horizontal bends BB1 and BB2 (LAL, CI)
  - design of standard warm FD magnets QF1 and SF1 (LAL)
  - design of a modified Panofsky quadrupole magnets (exploring possibilities) [feasibility,cost]
  - engineering design of QD0 and SD0 [feasibility for compact SD0 size,cost]
- **Other engineering and integration work**
  - Integration of final doublet into detector, including
    - cryostat design and FD support / services
    - anti-solenoid or skew-quadrupoles for coupling correction, with appropriate integration
  - design of beam pipe in shared area (LAL) [detailed drawings critical]
  - design of beam pipe in extraction line (LAL) [detailed drawings critical]

There is real flexibility in this scheme, with margins and adjustable parameters



# EDR plans

Aim of proposed EDR-phase 2 mrad tasks is to bring the design to the level of a credible alternative to the 14mrad baseline

OK

- Optics and beam transport
  - variable I\* IR and extraction line layout (CI)
  - further study of extraction line aberrations on final focus beam(CI, LAL)
  - iteration of design and losses as magnet designs progress (LAL, CI)
  - iteration of integration of 2 mrad FD in final focus optics (CI)
- Magnet design studies
  - design of large aperture final horizontal bends BB1 and BB2 (LAL, CI)
  - design of standard warm FD magnets QF1 and SF1 (LAL)
  - design of a modified Panofsky quadrupole magnets (exploring possibilities) [feasibility, cost]
  - engineering design of QD0 and SD0 [feasibility for compact SD0 size, cost]
- Other engineering and integration work
  - Integration of final doublet into detector, including
    - cryostat design and FD support / services
    - anti-solenoid or skew-quadrupoles for coupling correction, with appropriate integration
  - design of beam pipe in shared area (LAL) [detailed drawings critical]
  - design of beam pipe in extraction line (LAL) [detailed drawings critical]

There is real flexibility in this scheme, with margins and adjustable parameters

---

# Summary -1

- We should do the best we can with small crossing angle schemes
  - For such a challenging design as BDS, we should, if possible, have sensible alternatives & backups, not close off possibilities with potential technical, physics and / or cost advantages
- A viable alternative to the 14mrad baseline solution now seems both technically possible and cost-effective, this is the 2mrad scheme
- Plenty of progress has been made on beam transport, magnets, IR layout, backgrounds, collimation and so on
- Some design and engineering issues exist, and an EDR plan exists to confront these topics and allow a fair evaluation of alternative merits



---

# Summary -2

The existing team is prepared to bring this 2 mrad design & costing study to completion before end of 2008, provided :

- It is requested to do so by the GDE-EDR management
- Technical expertise becomes available in areas not within traditional LAL & Cockcroft competence, to help with the SC and some of the warm magnet engineering and costing

**Additional slides**

# Luminosity loss without crab-crossing (perfect conditions)

$L/L_0$

$\sim 0.85$

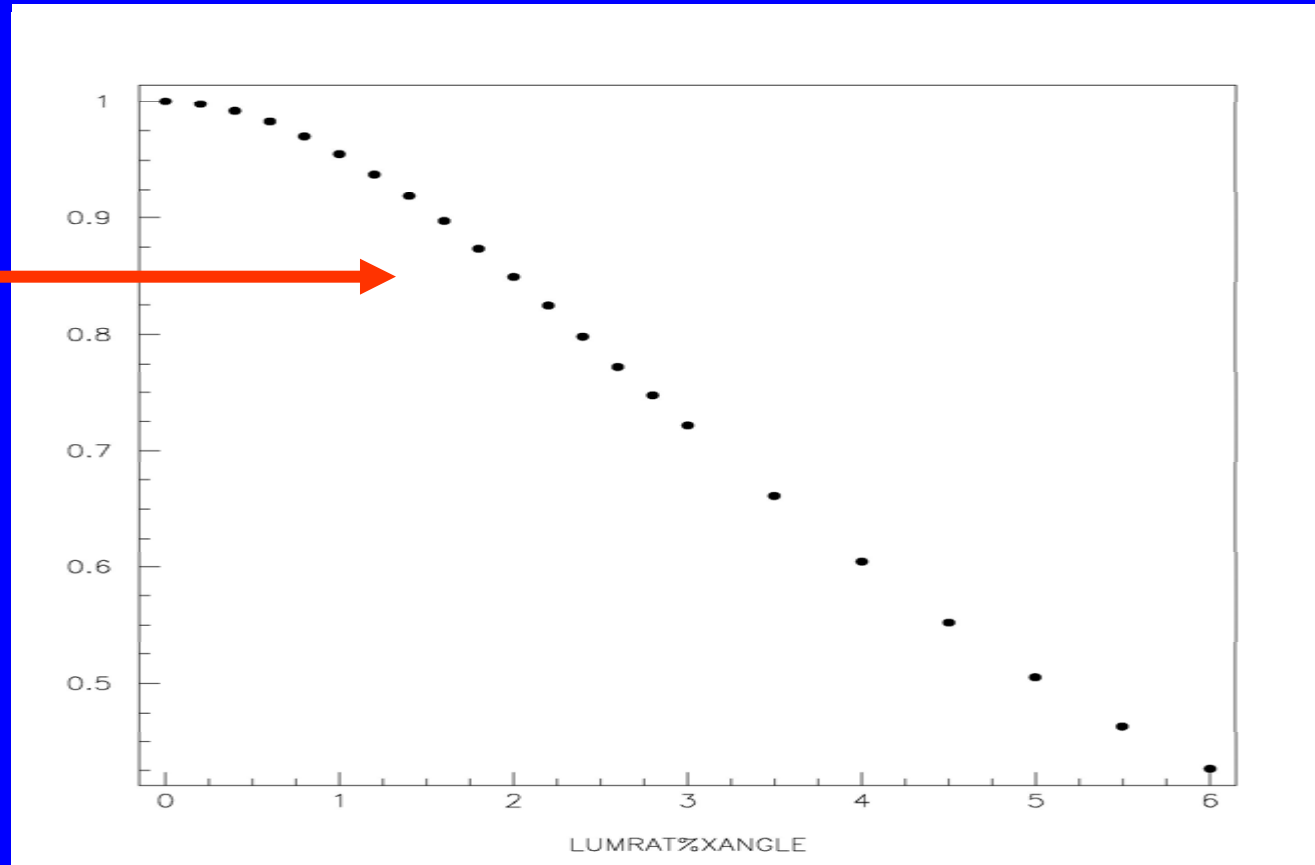

20 mrad  $\rightarrow L/L_0 \sim 0.2$

$2\theta$  [mrad]

# Symmetry consideration and BeamCal mask

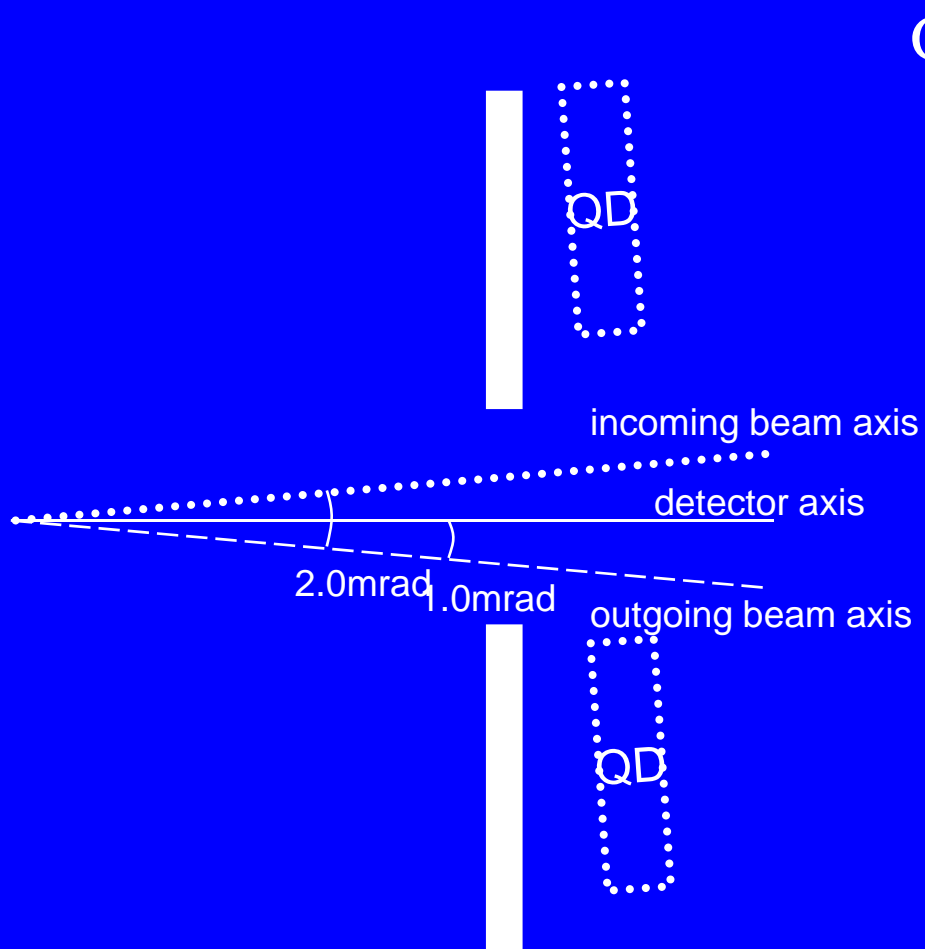

GLD

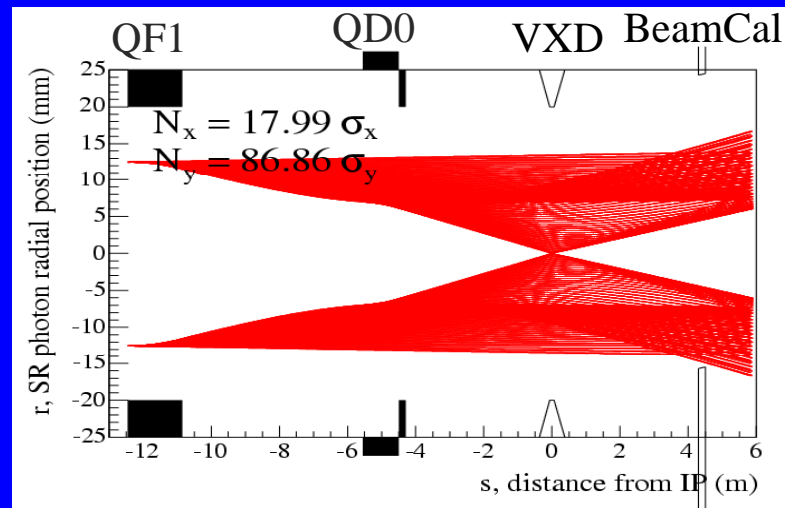

LDC

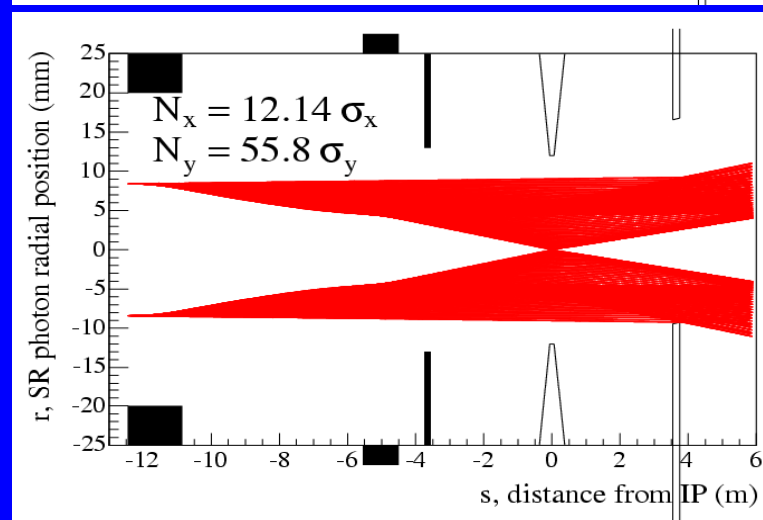

Best case GLD, worst case LDC, but the collimation depths are acceptable

BeamCal with  $r = 15\text{mm}$  in LDC, centred on detector axis  $\rightarrow$  OK clearances  
Effective BeamCal aperture of 7mm radius

# Optics for 500 GeV and 1 TeV

EUROTeV-Memo-2007-004

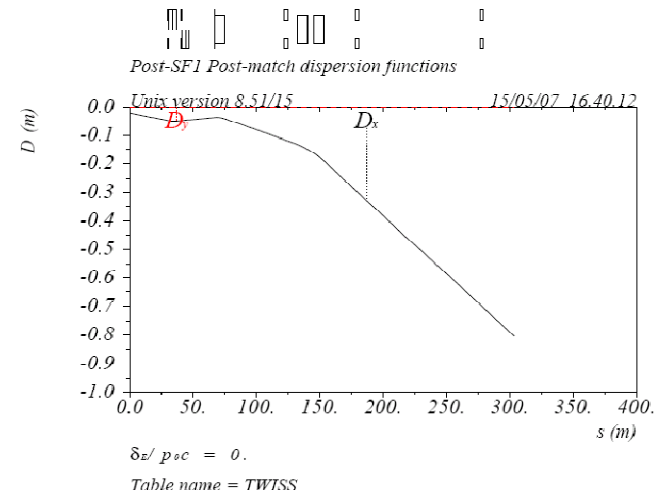
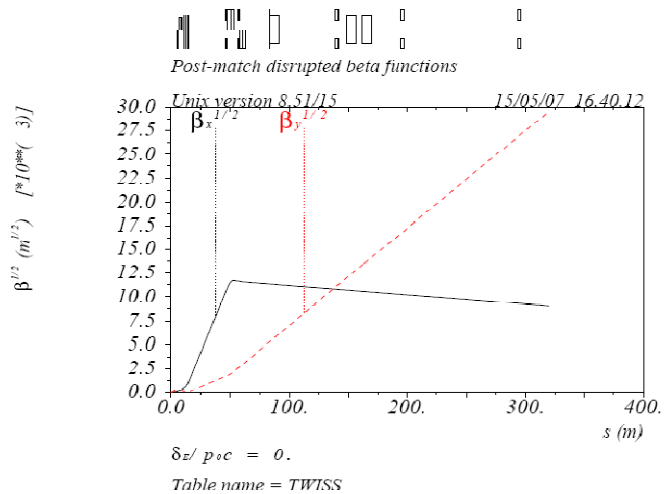
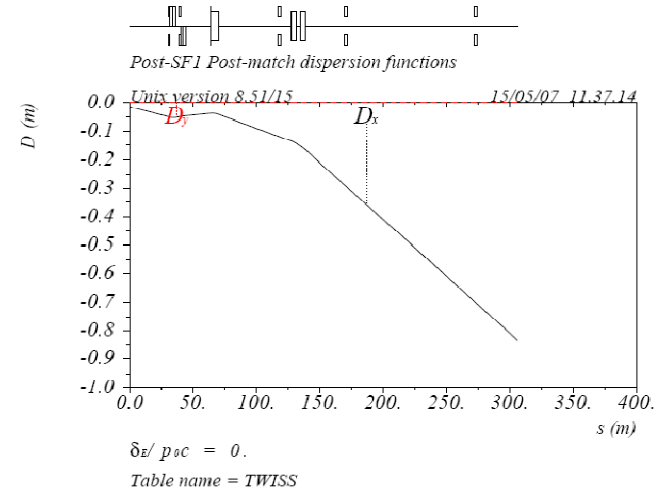
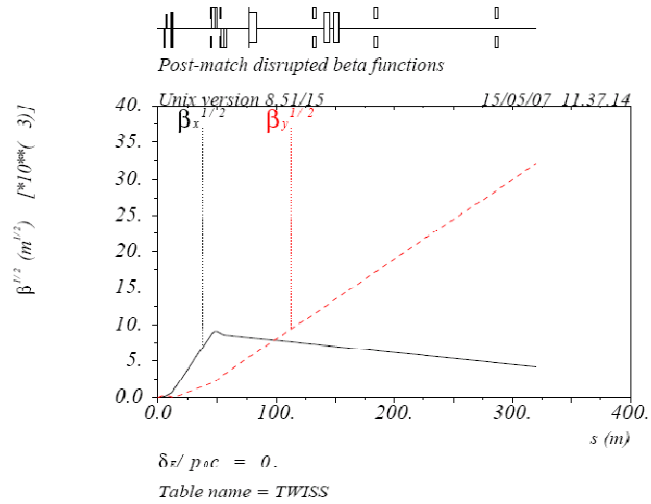

# Beam power losses

Beam	QEX1COLL [kW]	QEX1 [kW]	QEX2COLL [kW]	QEX2 [kW]	BHEX1 [kW]	COLL1 [kW]	COLL2 [kW]
Nominal	0	0	0	0	0	0.2	5.1
Nominal (dy=200nm)	0	0	0	0	0	0	2.9
Nominal (dx=1 $\sigma$ )	0	0	0	0	0	0.7	2.6
Low Power	2.8	0	1.3	0	0	65.3	50.0
Low Power (dy=120nm)	3.6	0	1.4	0	0	69.8	73.8
Low Power (dx=1 $\sigma$ )	1.4	0	0.7	0	0	34.5	19.3
High Lumi	12.3	0	4.4	0	0	202.1	131.9
High Lumi (dy=120nm)	14.8	0	4.5	0	0	200.0	195.8
High Lumi (dx=1 $\sigma$ )	8.3	0	2.8	0	0	101.9	49.1

Computed using GUINEA-PIG and DIMAD, for ILC parameter sets at machine energy of 500 GeV, with high statistics. Protection collimator jaws tuned to remove losses on magnets, and main collimator jaws tuned to loss specification of 200 kW and beam size on dump window.



# Mokka Simulation & Marlin reco.(2)

$\gamma$  generated with very small angle

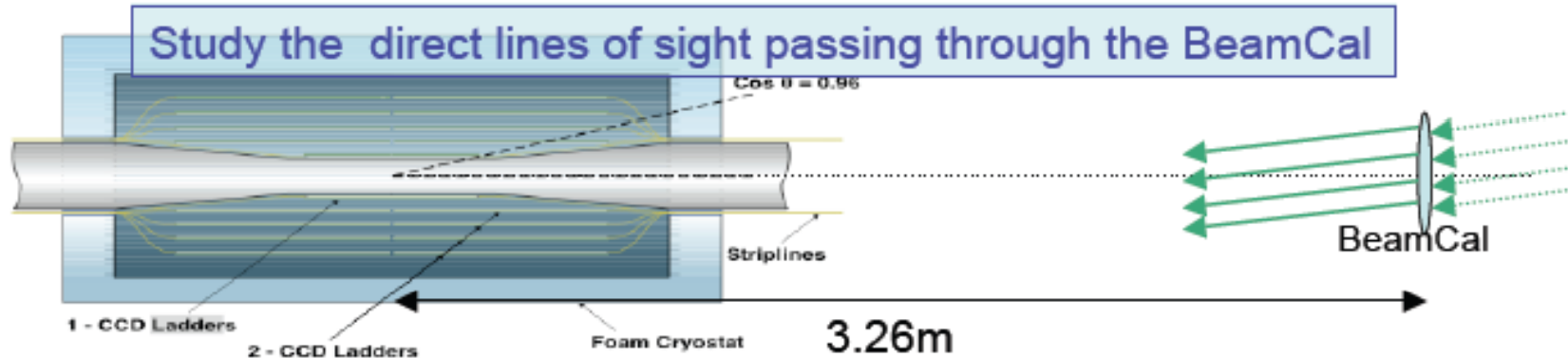

Generate photons:  $z=3.26$ , Circle( $x, y$ ),  $r=12\text{mm}$ ,  $\text{cos}\theta=X(20\text{cm})/Z(45\text{m})$   
(Beam loss position at QEX1COLL)

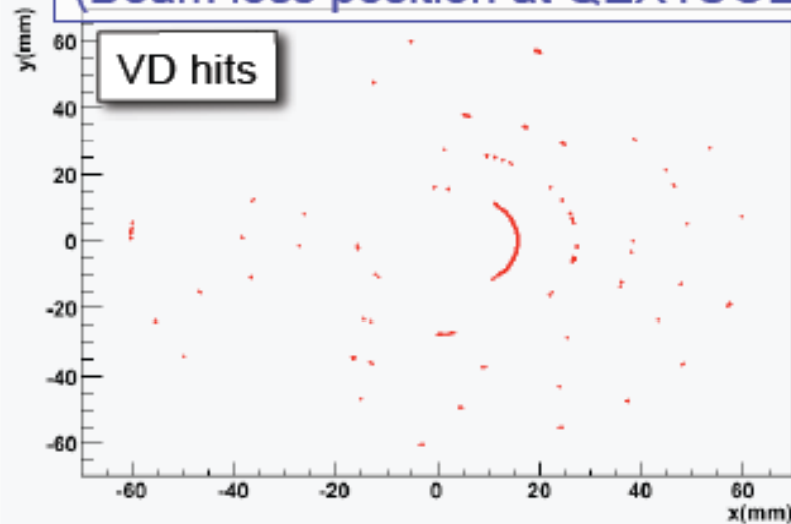

left-right asymmetry, emission point offset in one side

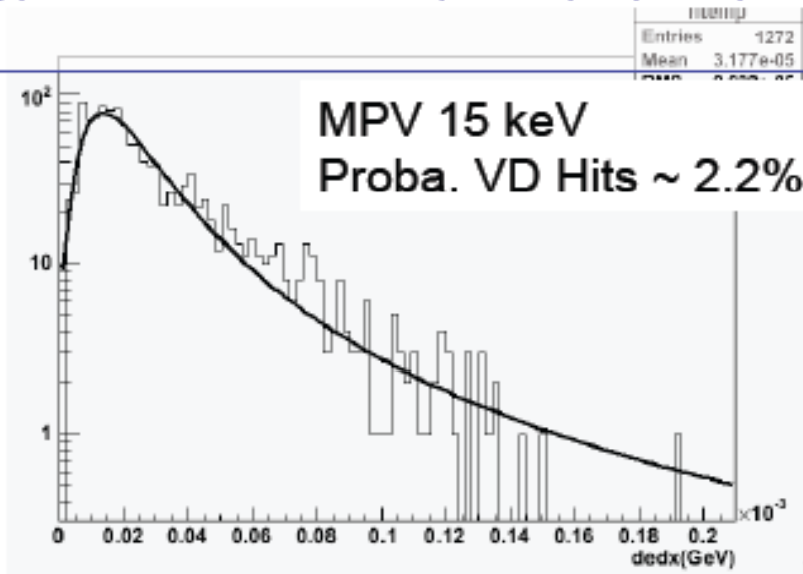

# Beamstrahlung photon cones

Horizontal cone distribution at 500 GeV

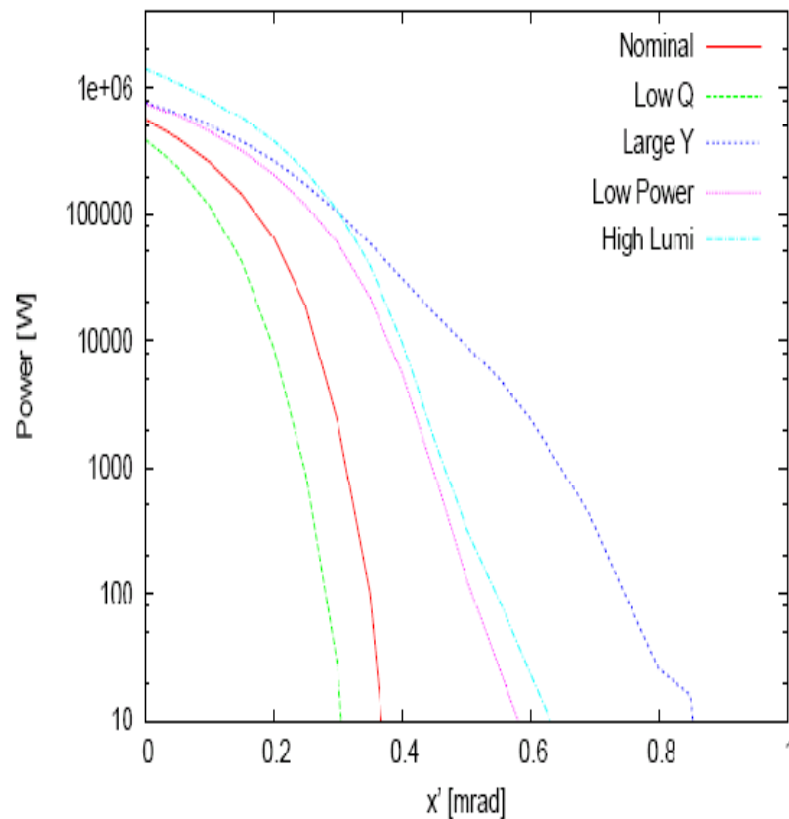

Vertical cone distribution at 500 GeV

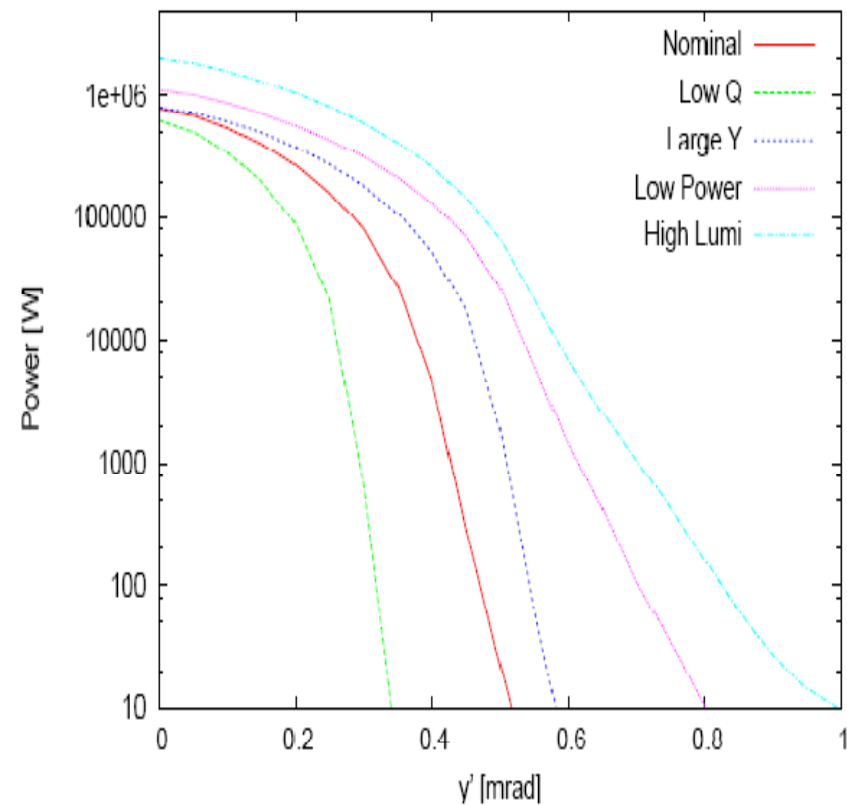

Integrated power beyond half- opening angle



# Combined Compton Luminometer & Polarimeter at IP ?!?

CEA/DAPNIA/SEA-97-14

**Luminosity Monitor Studies for TESLA**

Olivier NAPOLY  
CEA, DSM/DAPNIA  
CE-Saclay, F-91191 Gif-sur-Yvette Cedex, France

and

Daniel SCHULTE  
CERN, PS/LP  
CH-1211 Genève 23, Suisse

November 10, 1997

**Abstract**

The feasibility of a luminosity monitor based on a radiative Bhabha detector is investigated in the context of the TESLA linear collider. Another option based on low energy  $e^+e^-$  pair calorimetry is also discussed. In order to monitor the beam parameters at the interaction point by optimizing the luminosity, these detectors should be able to provide a relative measurement of the luminosity with a resolution better than 1% using only a fraction of the TESLA bunch train.

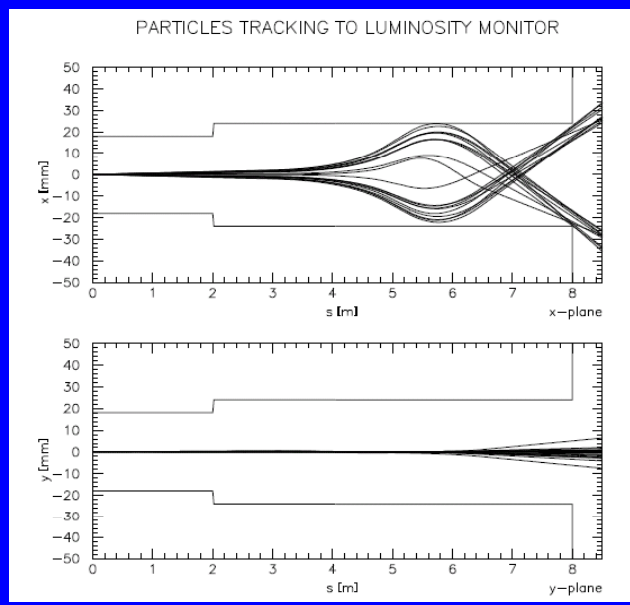
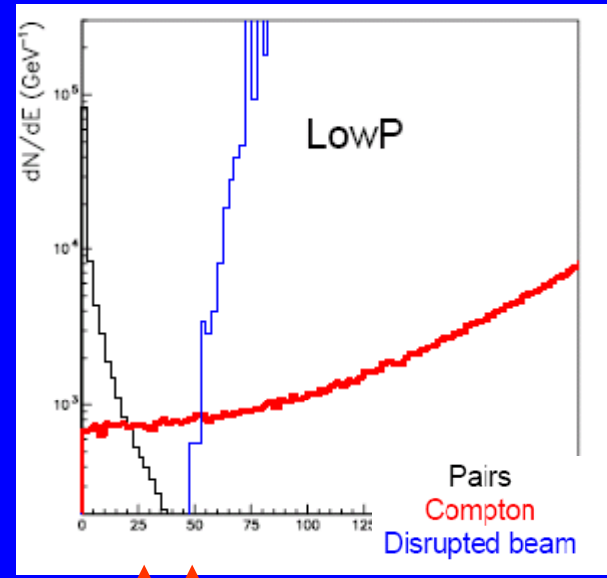
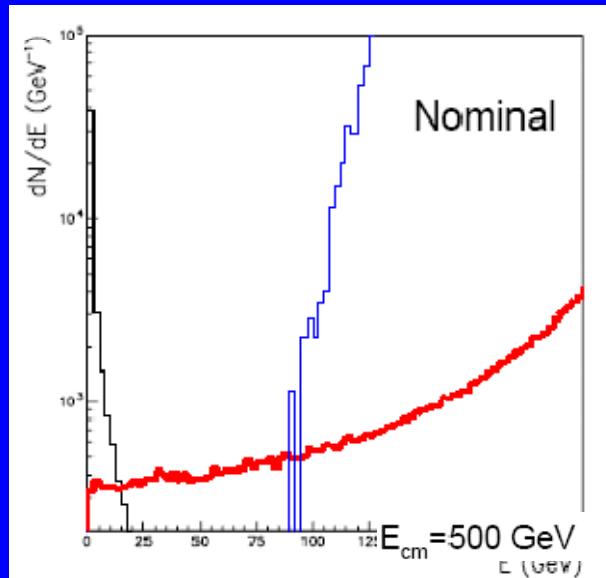

$4 \cdot 10^3$  luminosity  
Comptons / BX

- Laser focused 10 m from IP, to  $50 \mu\text{m}$
- $\theta_{\text{crossing-angle}} = 5 - 10 \text{ mrad}$
- $E_\gamma = 2.33 \text{ eV}$
- $\sigma_{z,\gamma} = 10 \text{ ps}$
- with  $\langle P \rangle = 25 - 50 \text{ W}$

$\rightarrow 2 - 4 \cdot 10^4$  Comptons / BX

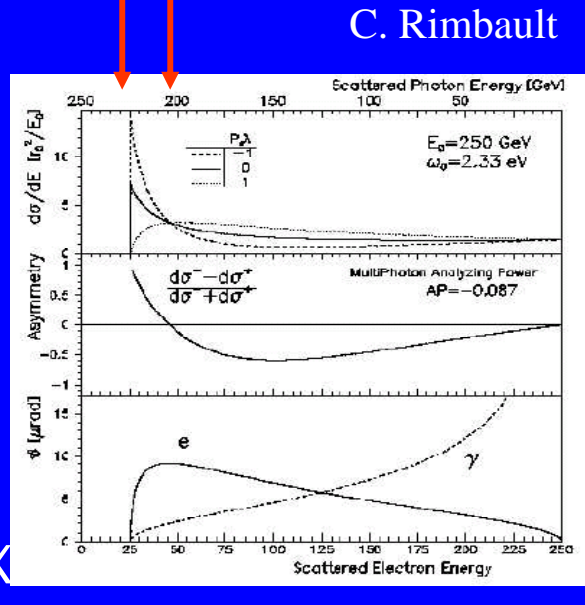

Collection efficiency ~ 5-10%

VERY PRELIMINARY

C. Rimbault

P. Schüller

# Combined Compton Luminometer & Polarimeter at IP ?!?

CEA/DAPNIA/SEA-97-14

## Luminosity Monitor Studies for TESLA

Olivier NAPOLY  
CEA, DSM/DAPNIA  
CE-Saclay, F-91191 Gif-sur-Yvette Cedex, France

and  
Daniel SCHULTE  
CERN, PS/LP  
CH-1211 Genève 23, Suisse

November 10, 1997

### Abstract

The feasibility of a luminosity monitor based on a radiative Bhabha detector

### PARTICLES HITTING LUMINOSITY MONITOR

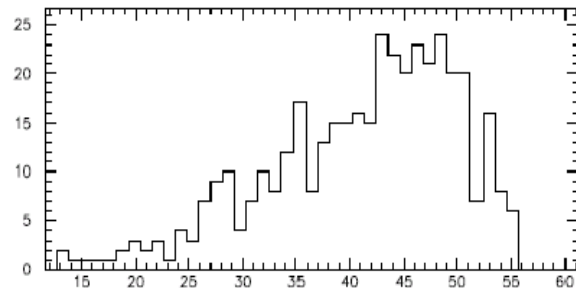

Energy Distribution

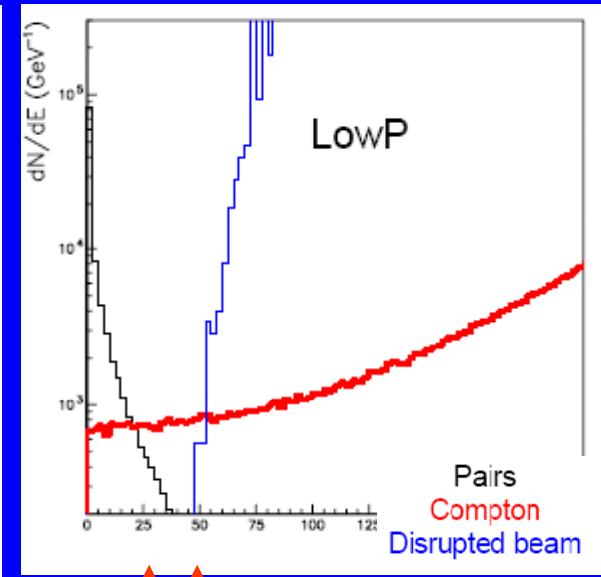
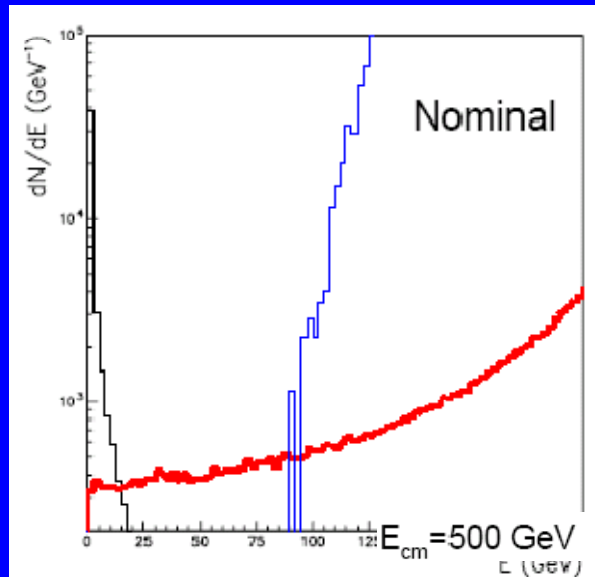
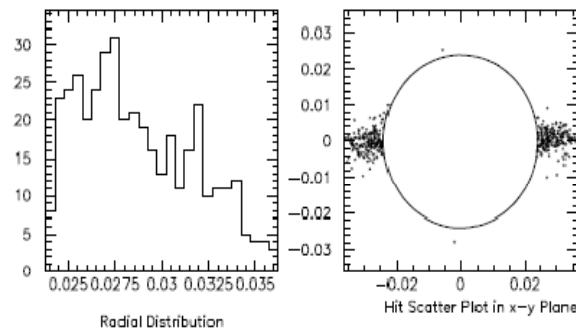

4  $10^3$  luminosity  
Comptons / BX

- Laser focused 10 m from IP, to 50  $\mu\text{m}$
  - $\theta_{\text{crossing-angle}} = 5 - 10$  mrad
  - $E_{\gamma} = 2.33$  eV
  - $\sigma_{z,\gamma} = 10$  ps
  - with  $\langle P \rangle = 25 - 50$  W
- $\rightarrow 2 - 4 \cdot 10^4$  Comptons / BX

C. Rimbault

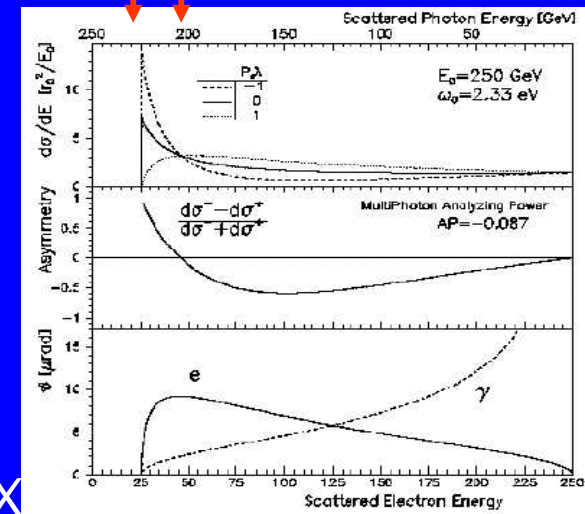

P. Schüller

Collection efficiency ~ 5-10%

VERY PRELIMINARY

# Connected beam dynamics and MDI investigations

Not 2 mrad specific → combine with head-on & 14 mrad work

- Spent beam diagnostics to monitor IP beam sizes & offsets
- Impact of non-axial detector solenoid and pre / post-IP trajectory bumps on beam setup and optical tuning
- Detector background from beam and SR losses
- Post-IP relative energy & energy spread measurements
- IP Compton luminometry and polarimetry with high power laser and instrumented mask near the FD
- Optical tuning strategy and feedback algorithms