

# On the use of ERL for gamma production

The use of ERL is appropriate when one uses only small part of the of electron beam power and the required average beam current (and, correspondingly, average power) are significant. This is just the case of generation of high flux of gamma-quanta by back Compton scattering, which was proposed recently as the alternative source of gamma-quanta for the ILC positron source.

## 1. On the Compton scattering

The Compton scattering is widely used at storage rings. One of the remarkable examples is the facility at Duke university FEL Lab.

For the electron beam size less than the optical r.m.s. beam size  $\sqrt{\frac{\lambda z_0}{4\pi}}$ ,  $\lambda$  is the wavelength,  $z_0$  is the Raleigh length, and light pulse duration more than  $z_0/c$  simple calculations give the average number of radiated photons per one electron  $\langle n \rangle$

$$\langle n \rangle = \frac{16\pi}{3 \cdot 137} \frac{P}{P_0} \approx \frac{P}{71 \text{GW}}, \quad (1)$$

where  $P_0 = c(mc^2/e)^2$ ,  $P$  is the light power.

For collision at the angle  $\theta$  is  $\langle n \rangle$  is reduced by the factor

$$\exp\left(-\frac{\pi\theta^2 z_0}{\lambda}\right) I_0\left(\frac{\pi\theta^2 z_0}{\lambda}\right) \approx \sqrt{\frac{2}{\pi}} \frac{1}{\theta} \sqrt{\frac{\lambda}{4\pi z_0}} \quad (2)$$

In the opposite case, when the light pulse r.m.s. duration  $\sigma_t$  is less than  $z_0/c$

$$\langle n \rangle = \frac{8}{3 \cdot 137} \frac{Wc}{P_0 z_0} \approx \frac{W}{1.5J z_0(\text{mm})}, \quad (1')$$

where  $W$  is the energy of light pulse. The angle crossing reduces  $\langle n \rangle$  by the factor

$$\left(1 + \pi \frac{c^2 \sigma_t^2 \theta^2}{\lambda z_0}\right)^{-1/2} \approx \frac{2}{c \sigma_t \theta} \sqrt{\frac{\lambda z_0}{4\pi}} = \frac{2z_0}{c \sigma_t} \frac{1}{\theta} \sqrt{\frac{\lambda}{4\pi z_0}}. \quad (2')$$

For finite transverse size of electron beam  $\sigma_x = \sqrt{\epsilon_x \beta_x}$  the decrease of the Raleigh length is limited by the value  $4\pi\sigma_x^2/\lambda$ . Therefore longer wavelengths may be preferable.

## 2. ERL parameters

To obtain high enough light power the high reflectivity mirrors and high average power lasers are necessary. Now they are available near 1 micron wavelength. For This wavelength electron energy about 1.5 GeV is required.

Modern accelerator technology may provide 1 A electron beam at maximum charge per bunch 5 nC and normalized emittance about 10 mm×mrad. It corresponds to maximum repetition frequency 200 MHz. For example, we can take 650/4=162.5 MHz. Then the average current at 5nC is about 0.8 A.

To provide high enough number of gamma quanta it is necessary to have  $\langle n \rangle \geq 1$ . Then the probability of radiation of two and three photons by the same electron is significant and the low energy tail in the distribution of used electrons appears. For the 30 MeV maximum energy of photons maximum energy loss by 3 photon emission is 90 MeV, i.e., 6% of initial energy.

High energy spread and average current eliminate the use of ERL with several orbits. For the single-loop ERL the transverse beam break-up due to excitation of high order modes in accelerating cavities may be suppressed by the 90-degree rotation of transverse (betatron) oscillation planes with proper set of skew quadrupoles or solenoids. To decelerate the beam with large energy spread the longitudinal phase space rotation may be used. It is achieved by the proper choice of the loop length (injection of the used beam to optimal decelerating phase) and the longitudinal dispersion coefficients  $R_{56}$  and  $T_{566}$  ( $c\Delta t=R_{56}(\Delta E/E)+T_{566}(\Delta E/E)^2$ ) between the interaction point and linac entrance. An example of such deceleration of particles, initially distributed at the interval from 1.41 GeV to 1.5 GeV is shown in Fig. 1.

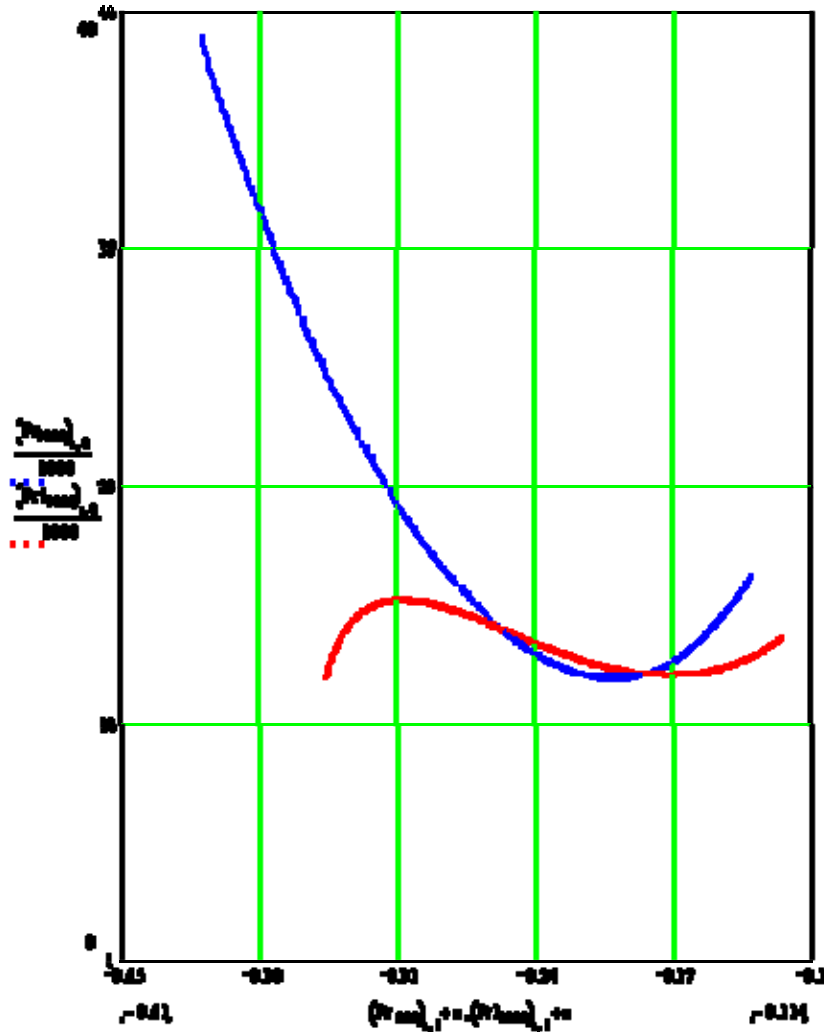

Fig. 1. Decelerated electron beam at the longitudinal phase space. Abscisse –from -0.45 to -0.1 radians of RF phase, ordinate – from 0 to 40 MeV. Blue –  $R_{56}=16.5$  cm ,  $T_{566}=0$ . Red –  $R_{56}=18.4$  cm ,  $T_{566}=120$  cm.

As it is seen from Fig. 1, the decelerated beam has average energy about 13 MeV within the interval  $\pm 2$  MeV. To transport the beam with high energy spread to linac, the Compton insertion have to be installed at the end of 360-degree loop of ERL.

To solve provide proper focusing of both accelerating and decelerating beams, the ERL scheme with accelerating and decelerating beams moving at opposite directions (see Fig. 2 a) may be used.

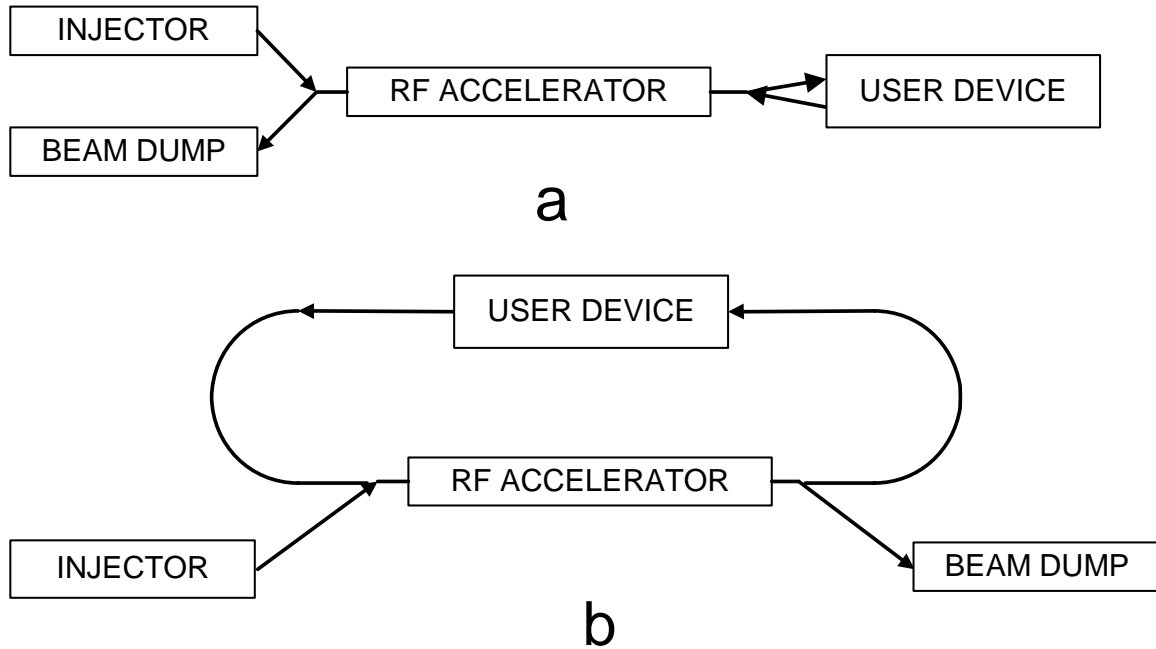

Fig. 2. Two schemes of ERL.

### 3. The use of FEL

Free electron laser (FEL) may be a good candidate as the light source for Compton scattering. It follows from the possibility to have very low light losses and high vacuum in the optical resonator of FEL. These FEL features make possible the use of intracavity high power light pulses and therefore eliminate special optical resonator, which is used to increase the energy of light pulses for other types of lasers. This mode of operation is successfully used for many years at the Duke University (USA) for several-MeV photon generation. But, to have high enough power it needs to use ERL for the FEL. It is natural to assume, that the FEL ERL has the same parameters, as the main one, but lower energy. Taking, for example, the wavelength 1 micron and undulator period  $\lambda_u = 10$  cm, one get electron energy about  $E \approx mc^2 \sqrt{(1+K^2)} \lambda_u / \lambda \approx 200 \text{ MeV}$  (for the undulator parameter  $K$  slightly more than 1). Then for the charge per bunch  $Q = 5$  nC the bunch energy is  $QE/e = 1$  J. The typical FEL efficiency is 1%. It means, that energy extraction per bunch is 0.01 J. For the optical resonator loss 0.1% it corresponds to 10 J energy per pulse. It worth noting, that the tolerances for the optical resonator length are much more relaxed, that ones for the resonance cavity used for amplification of “conventional laser” power. For 1.3 GHz RF the bunch and light pulses duration is about 10 ps FWHM. Then the peak light power in the optical resonator will be about 1TW.

The scheme of installation is shown in Fig. 3.

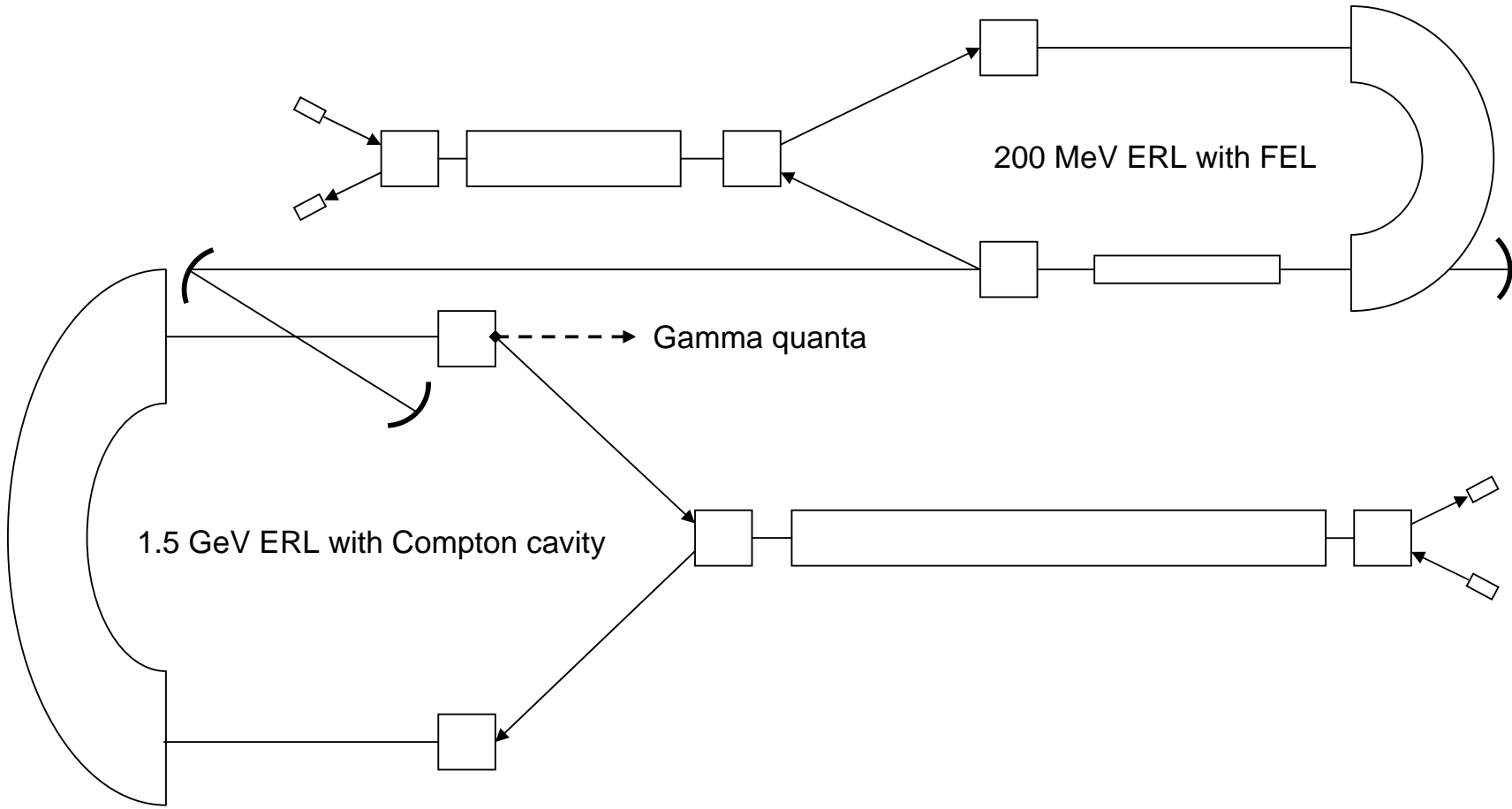

Fig. 3. Gamma quanta production with two ERLs.

More complicated optical resonators may be used to provide several crossing points of light and electrons.

#### 4. Example for gamma flux estimation

According to Eq. 2' the reduction factor is about the ratio of diffraction angular divergence of light to the crossing angle. If this ratio is more than  $\frac{1}{4}$ , the diffraction loss may be significant. So, we'll choose the reduction crossing angle to have reduction factor 0.1. Then, from Eq. (1) and Eq. (2), the average gamma quanta number per one electron is  $1000 \times 0.1 / 71 = 1.4$ . For the 5 nC charge per bunch it corresponds to  $4.4 \times 10^{10}$  gamma quanta per pulse and  $7 \times 10^{18}$  gamma quanta per second.

To obtain it the Raleigh length  $z_0$  must be less than  $10 \text{ ps} \times 3 \times 10^8 \text{ m/s} = 3 \text{ mm}$ . Taking  $z_0 = 2 \text{ mm}$  one has the r. m. s. light size  $\sqrt{\frac{\lambda z_0}{4\pi}} = 12.6 \text{ micron}$ , and the r. m. s. angular spread  $\sqrt{\frac{\lambda}{4\pi z_0}} = 0.0063$ . Then for the  $10 \text{ mm} \times \text{mrad}$  normalized emittance the electron beta function in the crossing point has to be less than 5 cm, and the crossing angle is near 50 milliradian = 3 degree.