



NANOBEAM 2008



BINP CAPACITIVE AND ULTRASONIC HYDROSTATIC LEVEL SENSORS

*A.G. Chupyra, G.A. Gusev, M.N. Kondaurov,
A.S. Medvedko, R.V. Pilipenko, Sh.R. Singatulin*

BINP, 630090, Novosibirsk, Russia





NANOBEAM 2008



1. INTRODUCTION
2. CAPACITIVE LEVEL SENSOR SASE
3. ULTRASONIC LEVEL SENSOR ULSE
4. DATA ACQUISITION SYSTEM OF LEVEL MEASUREMENTS
5. COMPARISON OF TWO KINDS OF THE SENSORS
6. REFERENCES



NANOBEAM 2008



1. Introduction

Slow ground motion study for future accelerator projects and alignment of large accelerator machine components with high accuracy are important tasks now. One of the prevalent tool for solution of these tasks are Hydrostatic Level Sensors designed to work into the Hydrostatic Levelling System, which is based on principle of communicating vessels. Each vessel is equipped with a sensor, measuring the water level. All water level measuring sensors are linked to its neighbors by a system of tubes. So the principle is based on the equilibrium of the pressure of liquid in communicating vessels.

The principal was even known in ancient Greece.



NANOBEAM 2008

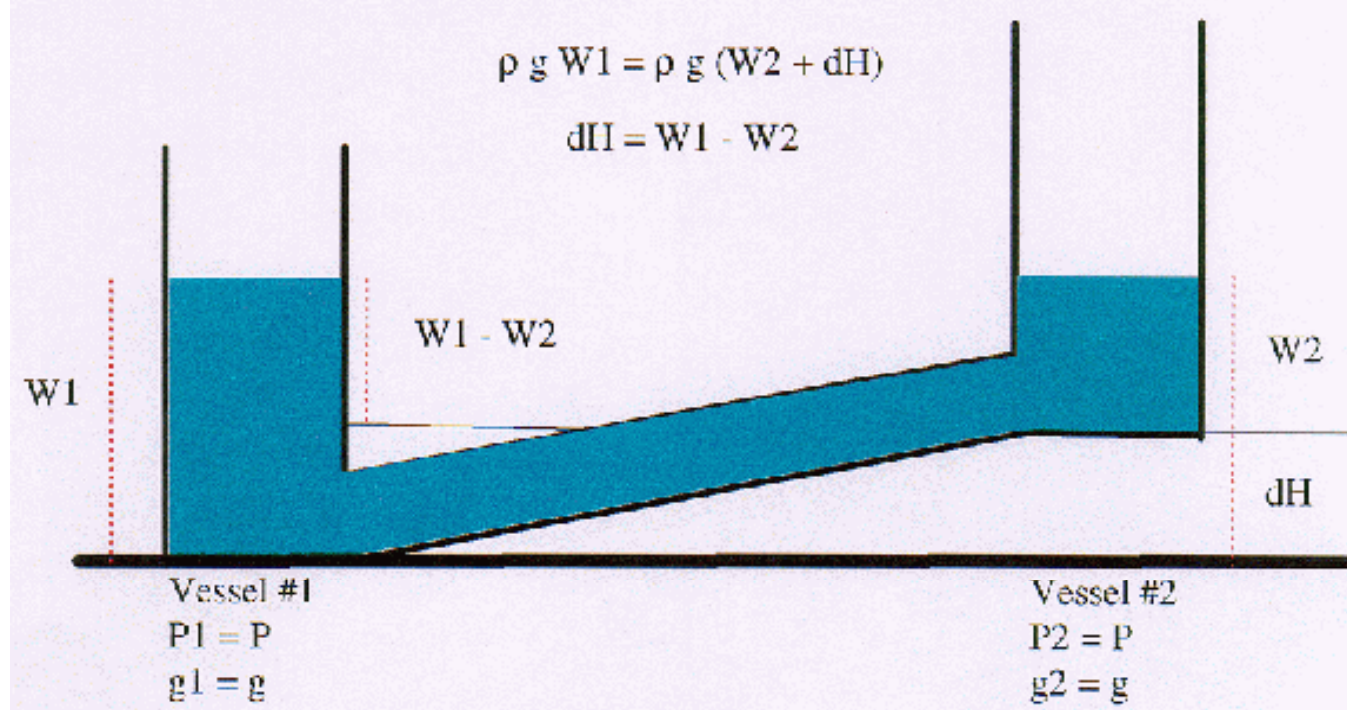

Assuming that the liquid used has a homogeneous density “ ρ ” and the gravitational force “ g ” and air pressure “ P ” are the same at both vessels, one can deduce the elevation difference between two vessels merely by subtracting the measured height of the liquid column at each vessel from the other.



NANOBEAM 2008



It can be assumed that the gravitational forces are almost identical at two vessel locations if the vessels are located in a less than 10 square km area.

An air circuit between the vessels is used to maintain the system at the same atmospheric pressure. There is only one small opening provided in the air circuit. The pressure from that location is distributed to all other vessels.

For measurements at room temperature, water is the simplest choice for the type liquid. It is inexpensive and safe.



NANOBEAM 2008

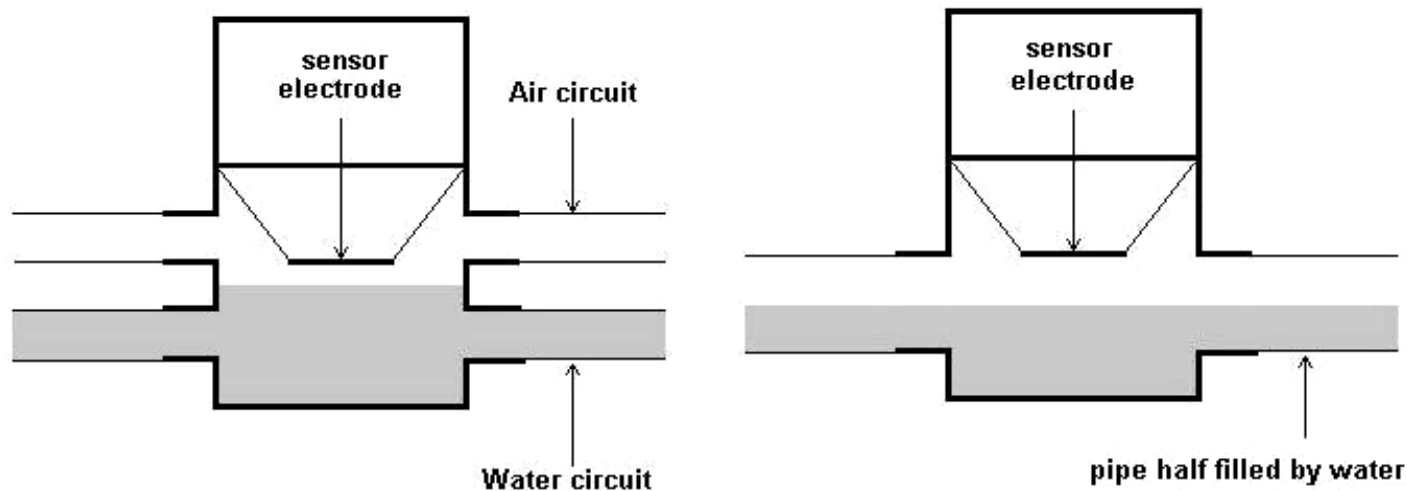

There are two kinds of hydraulic circuit configuration:

- 1) configuration with four vessel ports (two for air and two for liquid) using plastic pipes (as rule with I.D.=12 mm, O.D.=14 mm);
- 2) configuration, with two vessel ports using single pipe (I.D.=20 mm, O.D.=22 mm or more) half filled with water and horizontally placed enough to keep water-air gap continuity all along the pipe.



NANOBEAM 2008



The first configuration can have differential error produced either by water specific mass changing with temperature in case of non-horizontal hydraulic circuit or by outgassing and as, a result, air bubbles in water circuit. If bubbles are big enough to overlap water pipe they become an obstruction to liquid communication and create mistakes in measurements.

The second configuration has no differential error produced by water specific mass changing with temperature in principle and it has no any problems with air bubbles, but, of course, this kind of tubes need more delicate operation.



NANOBEAM 2008



The first BINP capacitive HLS sensor SAS at SLAC, Sector 10 in the network of slow ground motion study for NLC project.



A.Chupyra, BINP Novosibirsk,
May 25-30, 2008



NANOBEAM 2008



BINP-FNAL-SLAC slow motion studies and HLS R&D



BINP sensors @ MI-8

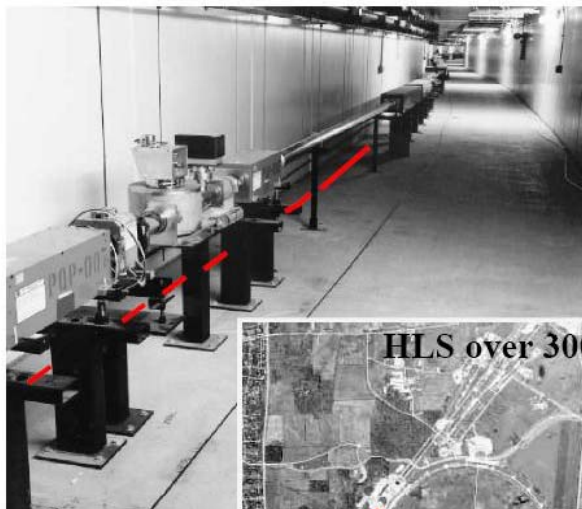

MI8 line
300m HLS
20 sensors





NANOBEAM 2008



HLS system at sector B of Tevatron, FNAL.

The system was installed on 2003 to study online a behaviour of Tevatron magnets.

It was installed 24 capacitive sensors on quadripole magnets at sector B.

Total pipe length is about 800 meters.





NANOBEAM 2008



In 2004 year the new modification of capacitive sensor (SAS-T) was developed. Equally with level measurement capability this sensor has a built-in two-coordinate tilt sensor. The range of tilt angle measurement is ± 17 milliradians with sensitivity better than 0.05 milliradian.



24 SAS-T sensors were delivered to FNAL in 2004. They were installed on magnet lines near detectors CDF and D0. The SAS-T was in detail presented in our report on IWAA04 [2].



NANOBEAM 2008



HLS system in MINOS tunnel (FNAL) to study ground motion for ILC project.

A.Chupyra, BINP Novosibirsk,
May 25-30, 2008



NANOBEAM 2008



In accordance with the program of collaboration between BINP and SLAC high-resolution capacitive (SASE) and ultrasonic (ULSE) hydrostatic level sensors for the Linac Coherent Light Source (LCLS) Undulator Alignment System were developed and fabricated. The required water level working range is ± 2.5 mm relative to the middle of the water communication pipe. The required resolution of the sensors must be not worse $1 \mu\text{m}$ with an accuracy of $5 \mu\text{m}$ over 5 mm measurement range. At first pilot series of the sensors was fabricated and tested. Then final version of the sensors was developed and fabricated.



NANOBEAM 2008



Test stand with pilot patterns of SASE and ULSE at SLAC. May 2006

A.Chupyra, BINP Novosibirsk,
May 25-30, 2008



NANOBEAM 2008



The overview of HLS monitoring system installation at LCLS undulator
(from report of Georg Gassner, SLAC - "HLS Monitoring System" August, 2006).

- 1 - Girder,
- 2 - ULSE sensor,
- 3 - SASE sensor

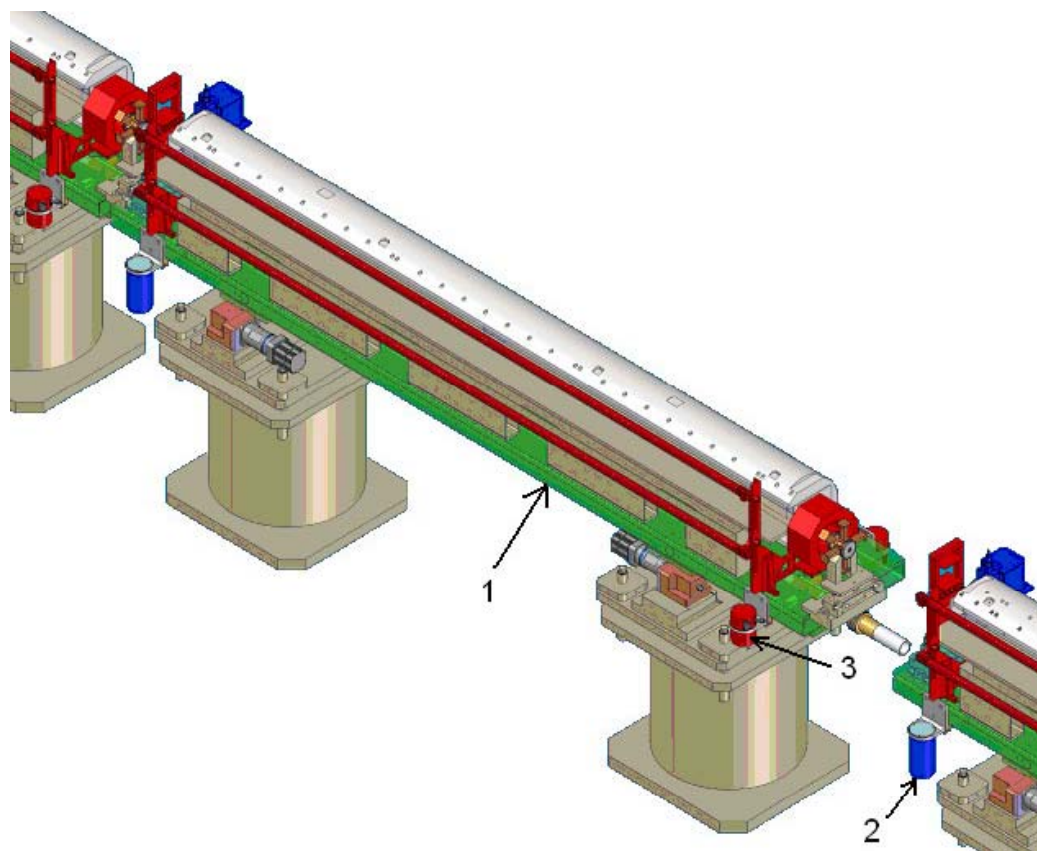



The detailed view of the sensor's
Installation on one girder:

1 – one **ULSE** sensor

2-4 – three **SASE** sensors

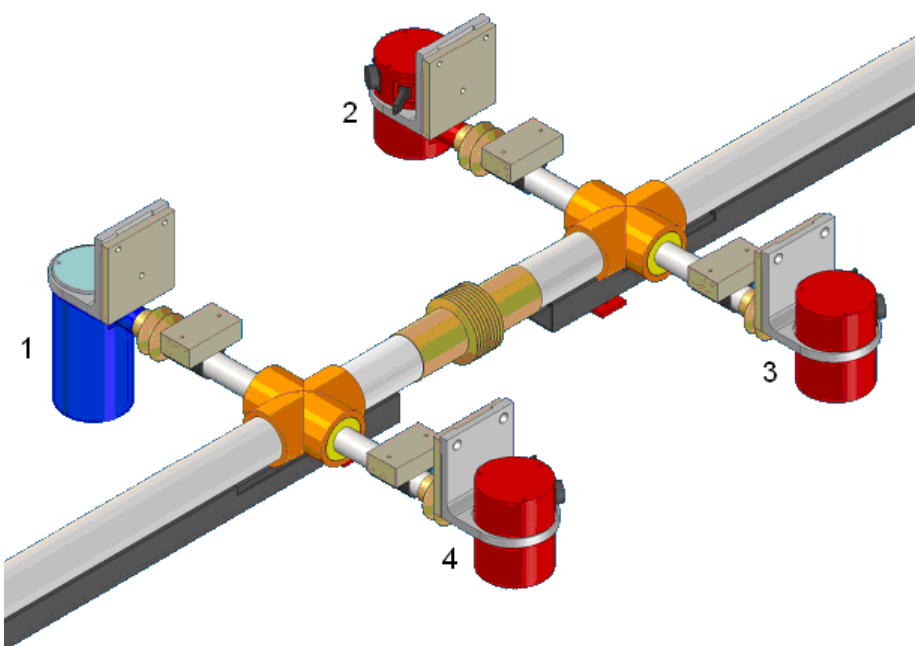

Goals on last development

- *To obtain required metrological characteristics:
working range 5 mm,
resolution not worse 1 μm ,
accuracy not worse 5 μm .*
- *Mechanical design of the sensors
must fit same water pipe and
same bracket*
- *The sensors must have same
interface for Data acquisition
system*



2 CAPACITIVE LEVEL SENSOR SASE

The presented capacitive level sensor SASE is intended for monitoring of LCLS Undulator vertical position:

- Displacement range - 5 mm ;
- Resolution – not worse 1 μm ;
- Accuracy - 5.0 μm ;
- Sampling rate – 0.5 Hz.

SASE works on principal of capacitance-based sensing. The principal is to create a capacitor, the liquid surface being one electrode, the sensor electrode placed in air medium upper of water surface being the second electrode of capacitor, the capacitance of which is measured in order to derive the distance between these two electrodes.



CAPACITANCE BASED METHOD OF LEVEL MEASUREMENTS

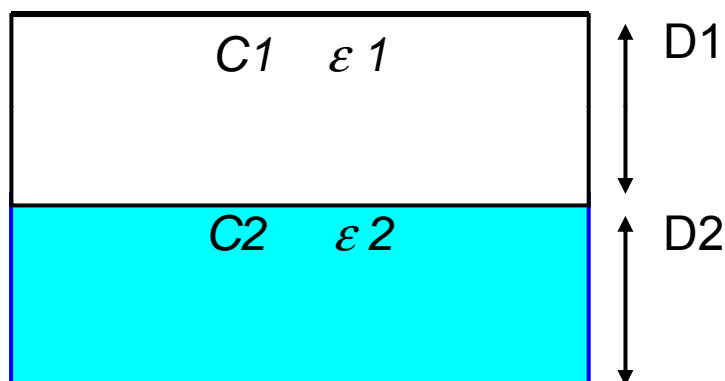

$$C_1 = \frac{A_1 \epsilon_1}{D_1} \quad C_2 = \frac{A_2 \epsilon_2}{D_2}$$

$$\frac{1}{C} = \frac{1}{C_1} + \frac{1}{C_2}$$

$$D_1 = \frac{A_1 \epsilon_1}{C(1-k)} - D \frac{k}{(1-k)}$$

$$D = D_1 + D_2$$

$$k = \frac{A_1 \epsilon_1}{A_2 \epsilon_2}$$



NANOBEAM 2008

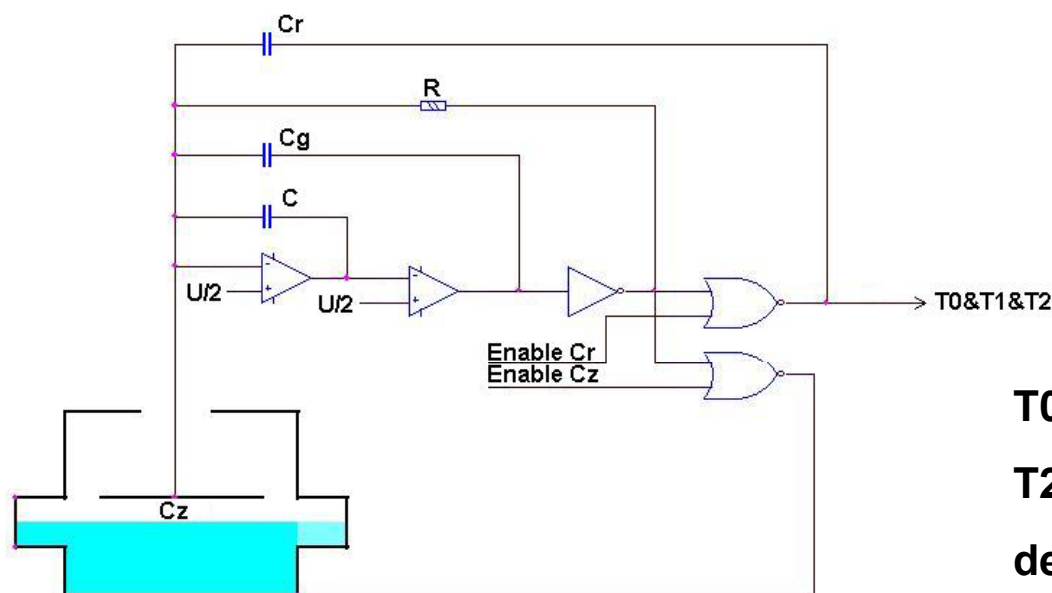

$$\frac{T_1 - T_0}{T_2 - T_0} = \frac{C_r}{C_z}$$

$T_0 \approx 11 \mu\text{sec}$

$T_2 \Rightarrow 11 \text{ to } 18 \mu\text{sec}$

depending on water level in vessel.

measurement period is 2 Hz.

$$\begin{aligned} T_0 &= 4 \times R \times C_g \\ T_1 &= 4 \times R \times C_g + 4 \times R \times C_r \\ T_2 &= 4 \times R \times C_g + 4 \times R \times C_z \end{aligned}$$

A method used for measurement is to convert variable capacitance into frequency, after that to convert the frequency to digital form. The developed circuit uses the idea presented at the work of N.Toth and Gerard C.M. Meijer [1]. General idea of the converter is an RC-generator with oscillating frequency determined by its internal parameters. To connect by turns C_r and C_z one can measure 3 periods T_0, T_1, T_2 and calculate C_z removing parasitic capacitance C .



NANOBEAM 2008

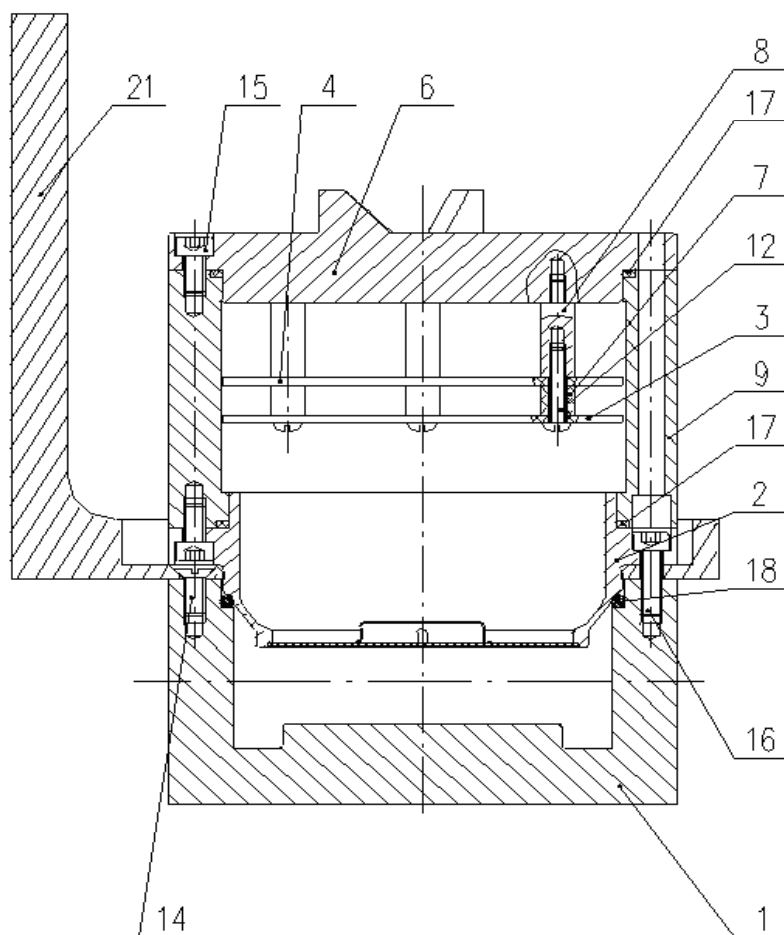

SASE consists of two independent parts: upper one with electronics inside (usually named as head) and lower one (usually named as vessel) filled with water. The general view of the sensor is shown at the picture on the left. All the body parts are done with stainless steel. On the top there is a special nest for a 1.5 inch ball to provide alignment survey. Inside the vessel there is a hole for placement of temperature probe.



NANOBEAM 2008



Picture of SASE general view.

A.Chupyra, BINP Novosibirsk,
May 25-30, 2008



NANOBEAM 2008



The electronics of SASE is mounted on two printed circuit boards. The board 1 includes **C=>F** converter and flash microcontroller. The board 2 includes Lantronix XPort [3], Power supply controller, DC-DC converter and transformer. On the picture below a view of the SASE electronics is presented. The board 1 is at the left side, the board 2 is at the right one.

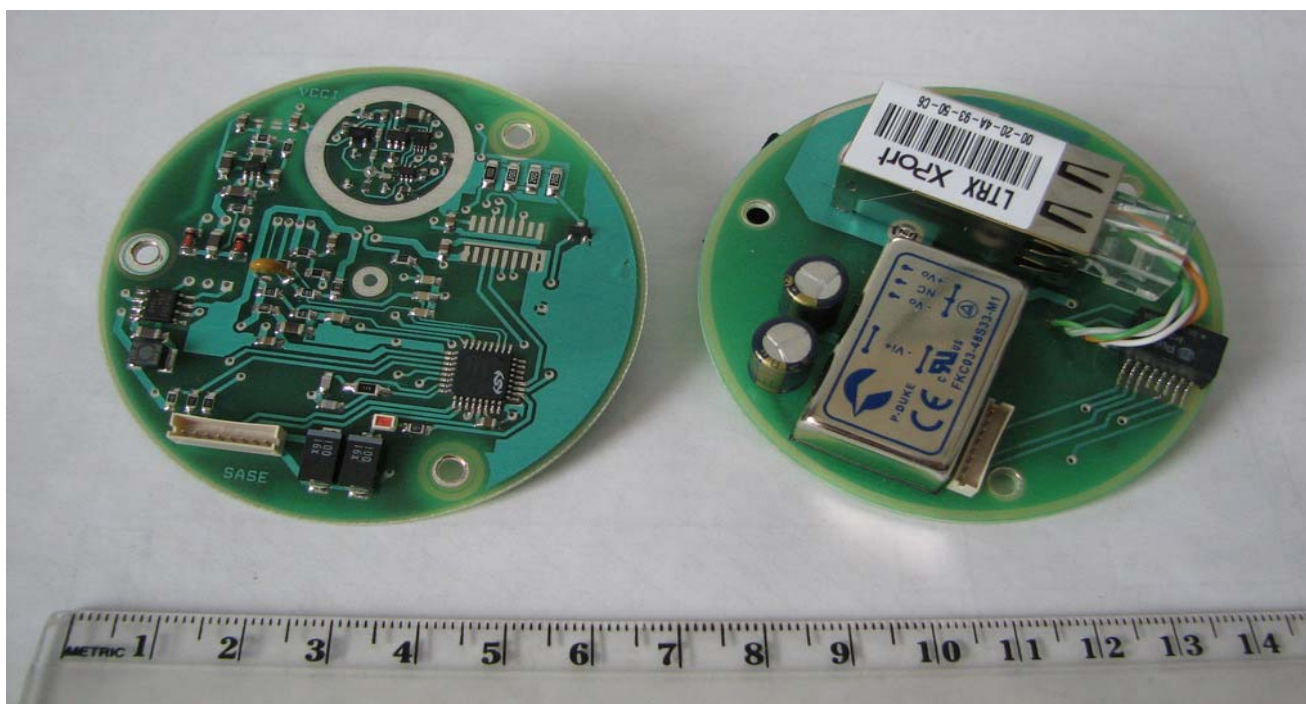

A.Chupyra, BINP Novosibirsk,
May 25-30, 2008



3. ULTRASONIC LEVEL SENSOR ULSE

The presented ultrasonic level sensor ULSE is also intended for monitoring of LCLS Undulator vertical position:

- Displacement range - 5 mm ;
- Resolution – not worse 0.2 μm ;
- Accuracy - not worse 5.0 μm ;
- Sampling rate – 100 Hz.

A pulse-echo method is used in ULSE for water level measurements. The ultrasonic hydro-location is well known and widely distributed method of distance measurements for many applications.



NANOBEAM 2008



Some basic principles of the pulse-echo method for water level measurements:

- Determine the location of free water surface in a vessel
- Accurately measuring the time required for a short ultrasonic pulse, generated by a transducer, to travel through a thickness of water, to reflect from the free water surface or from the reflective surface, and to be returned to the transducer.
- The result is expressed by the relation:
- d is the distance,
- v is the velocity of sound waves in water,
- t is the measured round-trip transit time.

$$d = v \cdot t / 2$$



NANOBEAM 2008



One of precise methods was described by Markus Schlösser and Andreas Herty at their report presented at the 7th International Workshop on Accelerator Alignment [4]. Their idea is to locate not only the water surface in a vessel, but also two addition surfaces with calibrated distance between them and at the calibrated distance to alignment reference target. This idea pushed us to develop the Ultrasonic Level Sensor for precise measurement of the absolute vertical displacements of accelerator structures.



NANOBEAM 2008

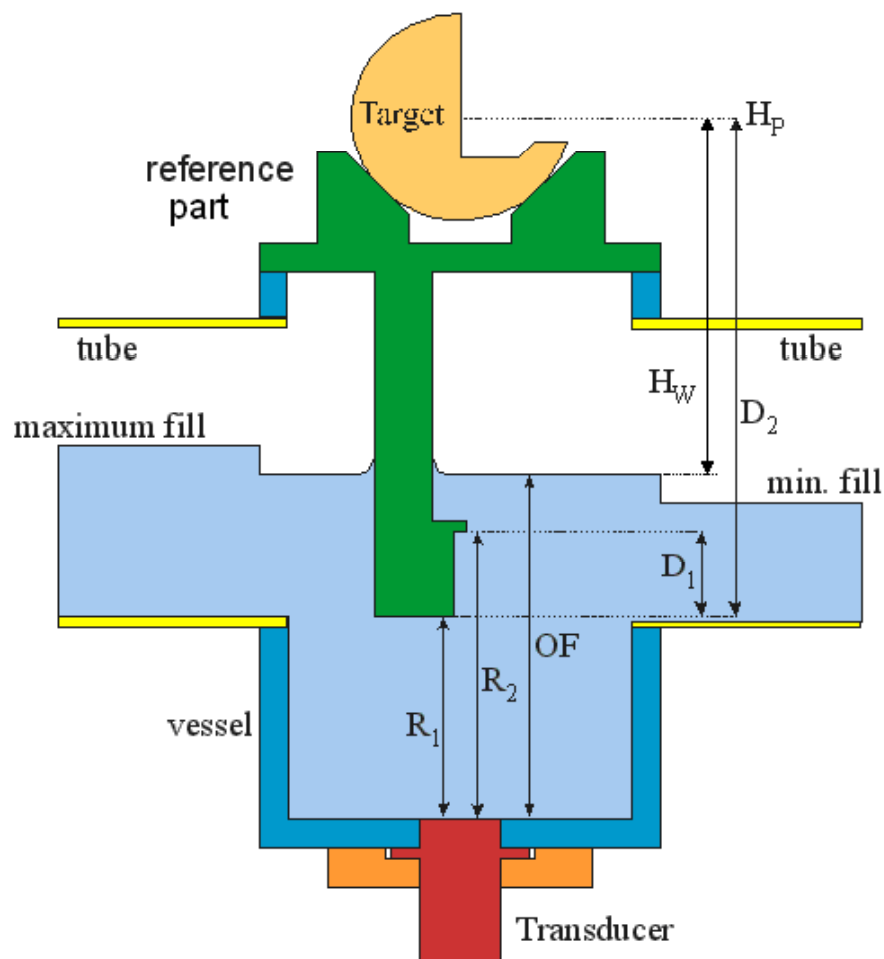

Principle of organizing the reference surfaces at the ULSE

(Picture is from the M. Schlösser & A. Herty report)

$$H = D_2 - D_1 \cdot \frac{t_{of} - t_{R1}}{t_{R2} - t_{R1}}$$

H - distance from the water surface H_w to external reference surface (point) H_p



NANOBEAM 2008



Special transducers => immersion transducers

- Transducers are designed to operate in a liquid environment
 - They usually have an impedance matching layer that helps to radiate more sound energy into the water and to receive reflected one.
 - Immersion transducers can be equipped within a planner or focused lens.
 - A focused transducer can improve sensitivity and axial resolution by concentrating the sound energy to a smaller area.
 - The sound that irradiated from a piezoelectric transducer does not originate from a point, but from all the surface of the piezoelectric element.
 - Round transducers are often referred to as piston source transducers because the sound field resembles a mass in front of the transducer.
- Choice of transducer for ULSE and physics of hand-picked transducer were in detail described in our report on IWAA06 [5].



NANOBEAM 2008

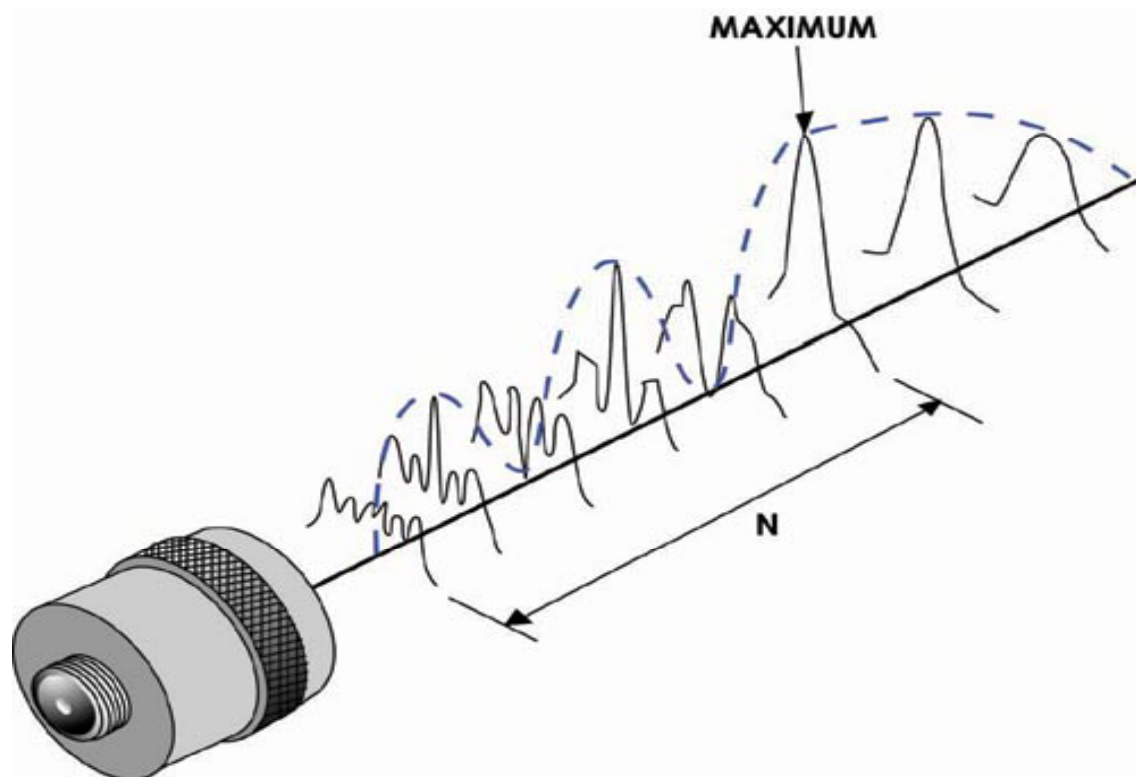

For a piston source transducer with:

Diameter D ,

Central frequency f ,

Sound velocity V

the estimation of the near/far field transition point:

$$N = f \cdot (D/2)^2 / V$$

Sound field pictures of the typical piezoelectric transducer



NANOBEAM 2008



Characteristics of Krautkramer H10KB3 ultrasonic transducer

HF-Signal/RF Signal

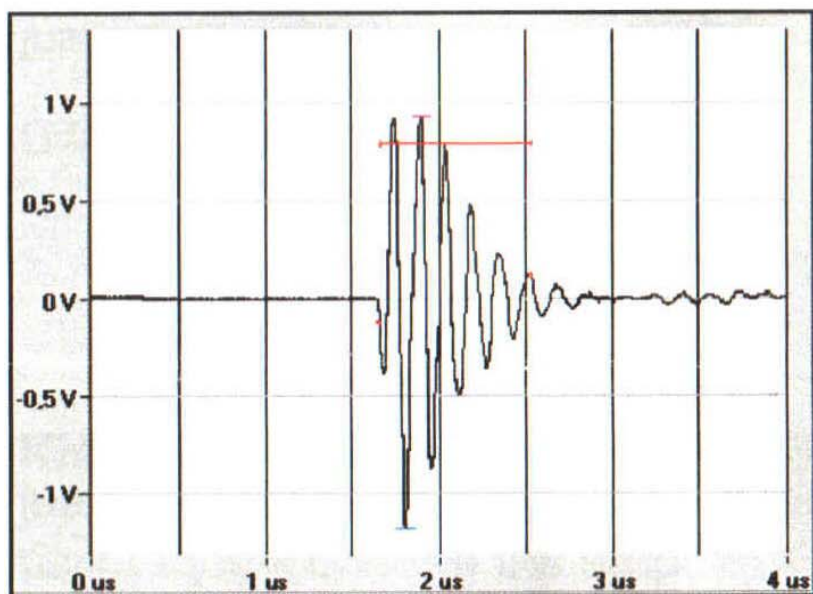

Spektrum/Spectrum

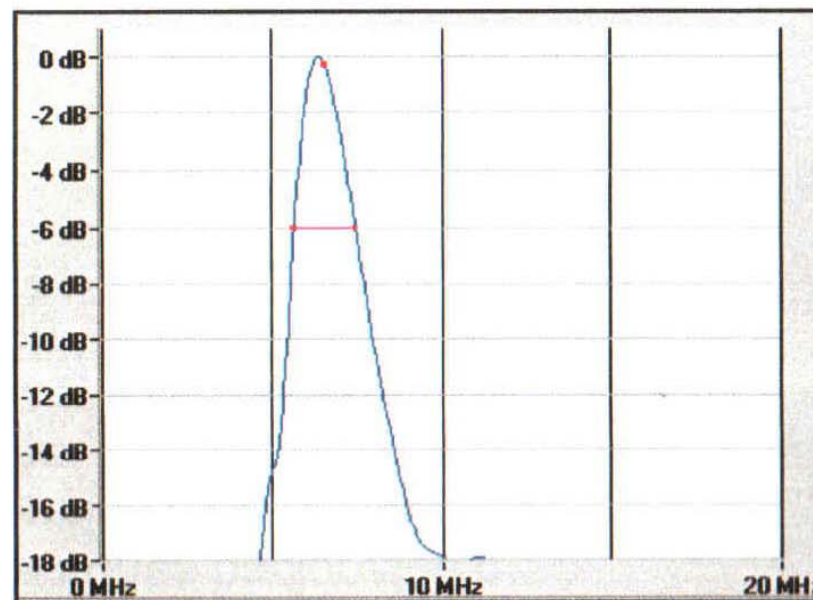



NANOBEAM 2008



In compliance with the mechanical design of the ULSE we should measure three distances: *R1*, *R2*, *OF*

Type	<i>R1</i>	<i>2t</i>	<i>R2</i>	<i>2t</i>	<i>OF</i>	<i>2t</i>	<i>dH</i>	<i>dt</i>
	<i>mm</i>	<i>μs</i>	<i>mm</i>	<i>μs</i>	<i>mm</i>	<i>μs</i>	<i>mm</i>	<i>μs</i>
ULSE	55	74.17	62.5	84.29	75	101.46	±2.5	±1.7

Sound velocity in water equal to 1483m/sec at 20°C.

Displacement resolution $0.2\mu\text{m}$ => time resolution 140 picosecond

Accuracy about $5\mu\text{m}$ => accuracy about 3.4 nanosecond.

The signal repetition frequency at the ULS was chosen 100 Hz.

One second averaging time interval for different systems comparison.



NANOBEAM 2008



$$H = D_2 - D_1 \cdot \frac{t_{of} - t_1}{t_2 - t_1}$$

The goal of ULSE electronics is to measure time intervals with the accuracy as fine as possible and to calculate the resulting values

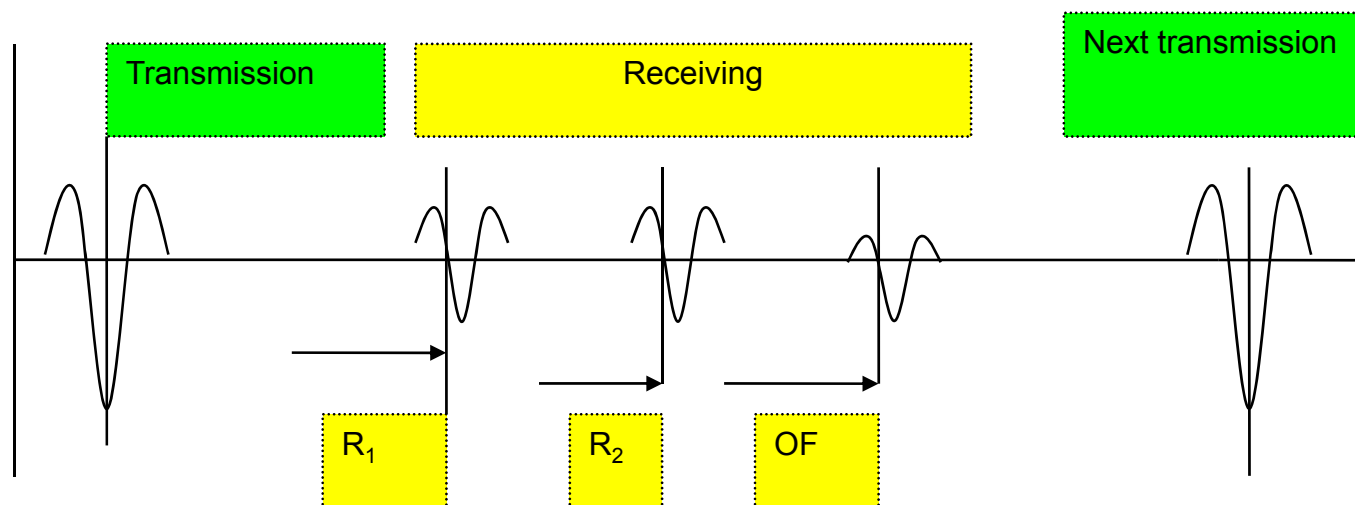

Time diagram of one measuring cycle



NANOBEAM 2008

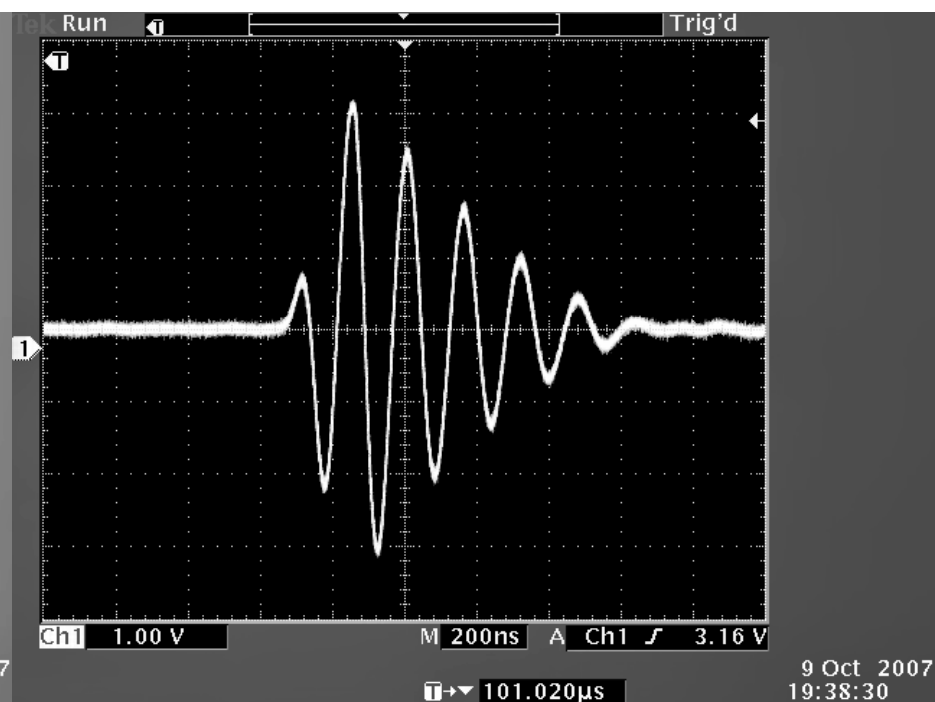
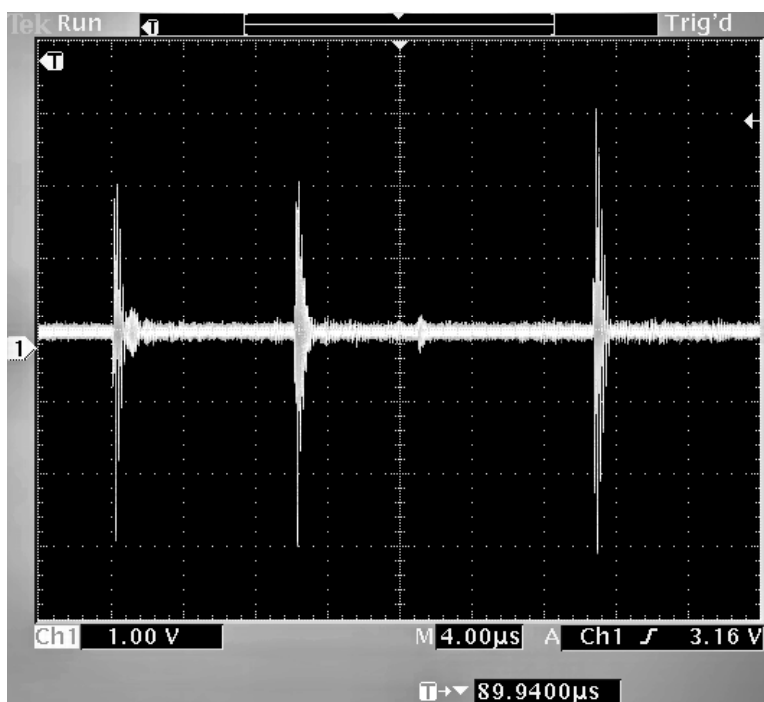

Real oscillograms of reflected signals.



NANOBEAM 2008

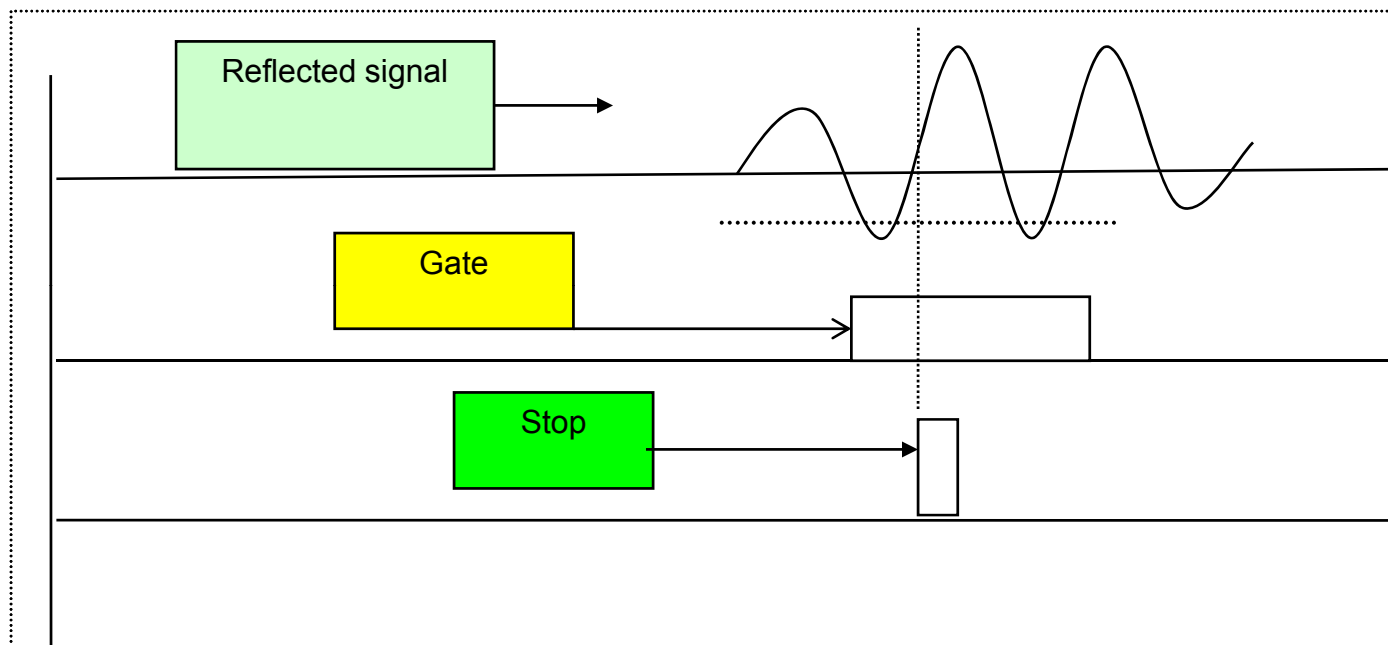

Time diagram of "zero level" comparator operation



NANOBEAM 2008

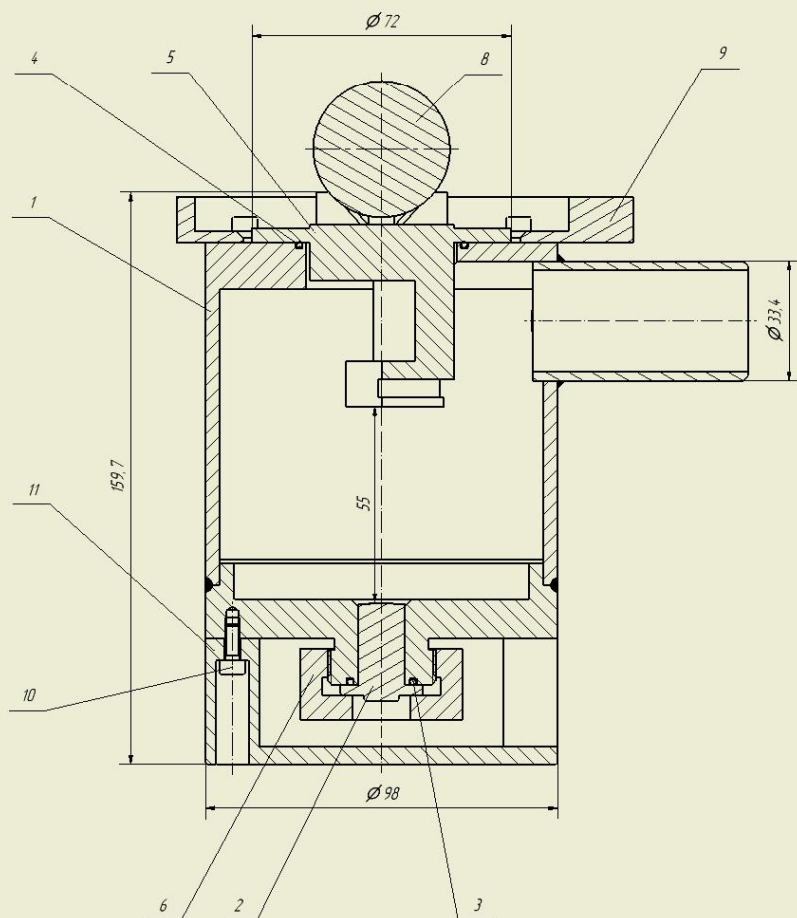

ULSE consists of ultrasonic transducer, vessel with tube outlet, reference part, temperature probe. The reference part has two reference surfaces to calibrate the measurements and special nest for a 1.5 inch ball to provide alignment survey. There are no any electronics inside the body of ULSE. The electronics is placed into separate box, which can be located on some distance (up to 2 meters) from the mechanical body of ULSE.



NANOBEAM 2008



General view of the ULSE and its electronic box.



NANOBEAM 2008

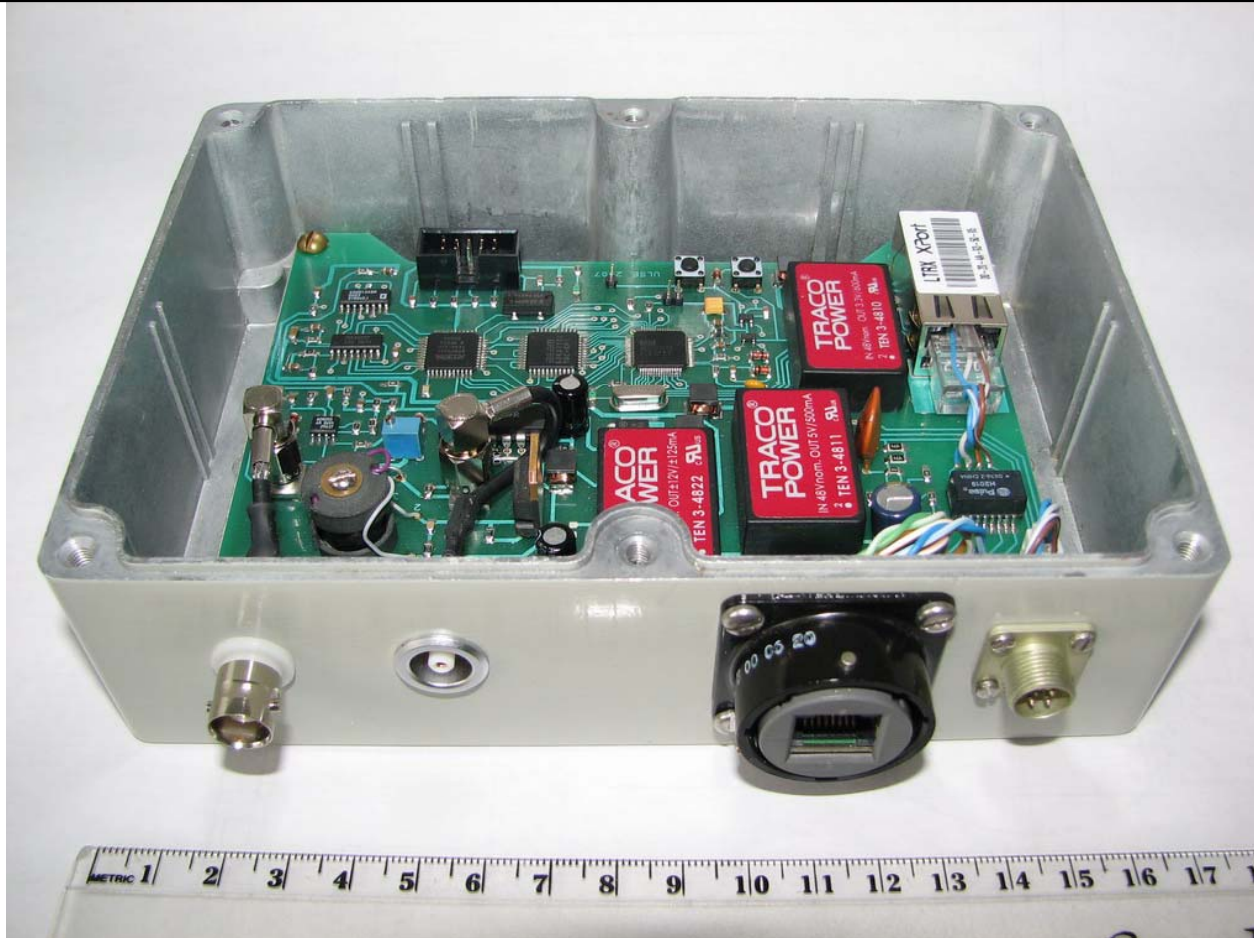
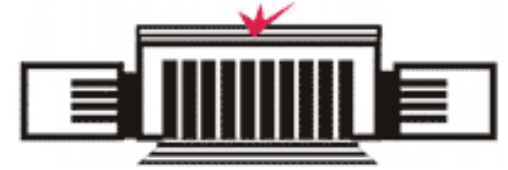

The internal view of the box with electronics.

A.Chupyra, BINP Novosibirsk,
May 25-30, 2008



NANOBEAM 2008

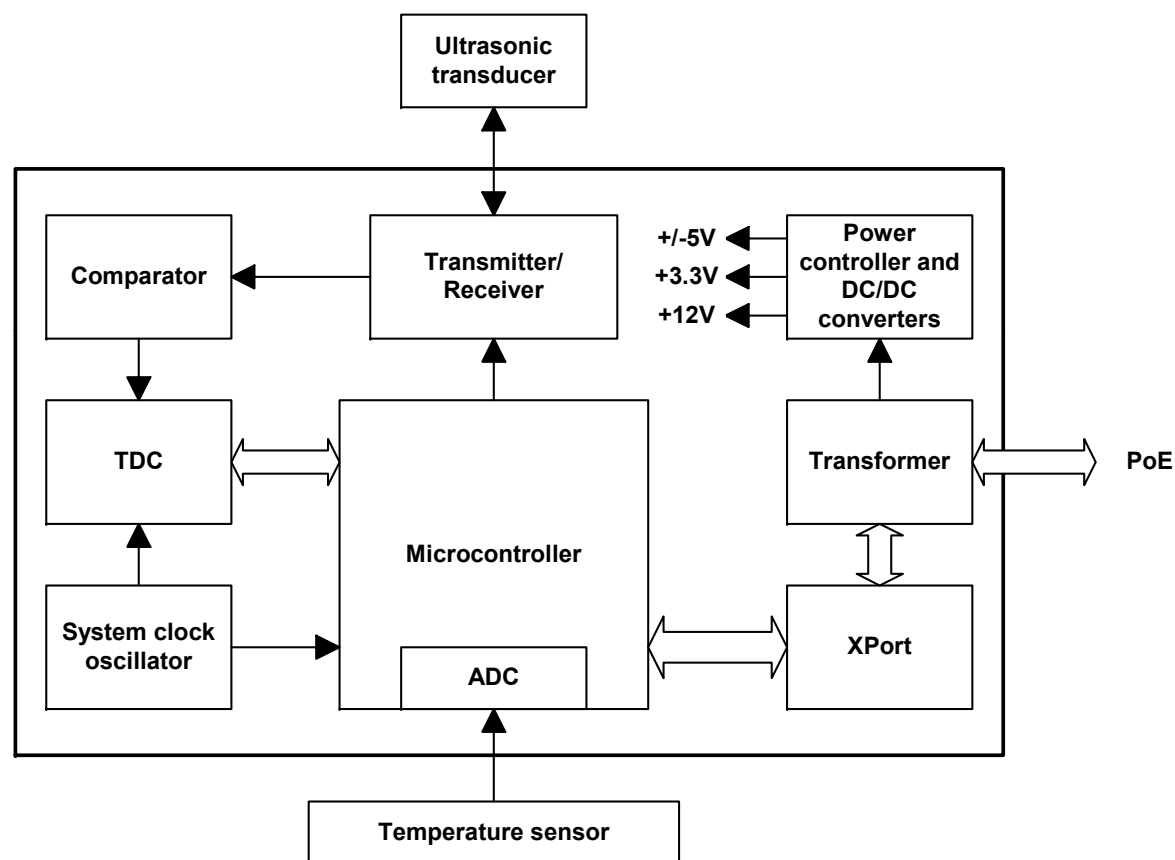

Functional circuit diagram of the ULSE electronics



4. DATA ACQUISITION SYSTEM OF LEVEL MEASUREMENTS

Data acquisition is organized with help of Local Area Network based on Power over Ethernet (**PoE**) interface and standard system of commands *Field Point F1001*, National Instruments Corp [6].

PoE interface is a system to transmit electrical power, along with data, to remote devices over standard twisted pair cable in an Ethernet network.

PoE interface operates under IEEE 802.3af specification. The specification provides 48 V DC over two out of four available pairs on a Cat3./Cat5. cable with a maximum current of 400 mA for a maximum load power of 15.4 W.



Functional diagram of HLS Data acquisition system.

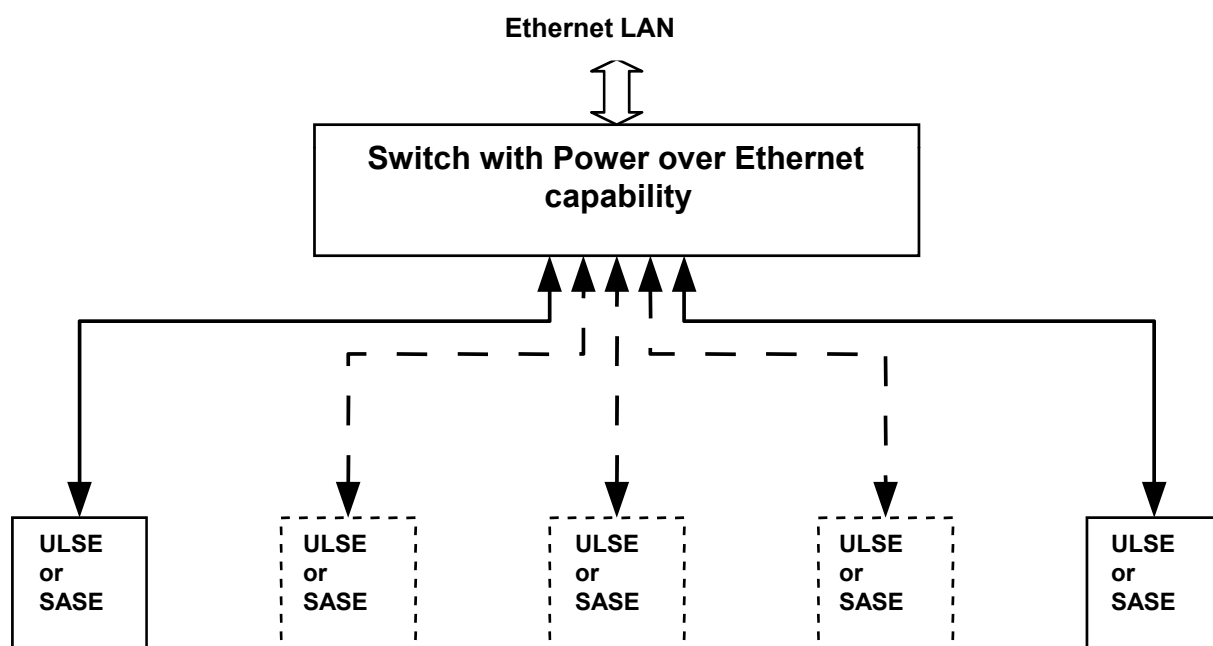

- All sensors (ULSE or SASE type) are connected up to standard switches with Power over Ethernet capability (one channel of the switch per one sensor).
- The switches are connected to local area network based on Ethernet.
- Number of the used sensors can easily vary by changing number of switches.
- Length of the connecting cables between the sensors and the switches can be as long as 100 meters.



5. COMPARISON OF TWO KINDS OF THE SENSORS

Ultrasonic sensor has a lot of benefits in comparison with capacitive one:

- more high absolute accuracy
- more sensitivity at more high sample rate
- measuring data don't depend on electronics drifts (temperature and time) because of calibration capability during each measuring cycle
- no dependence of relation "signal/noise" from measuring level
- high linearity of transfer coefficient (output signal => level)
- no need in precise calibration – only accurate measurement of two linear sizes for reference part



NANOBEAM 2008

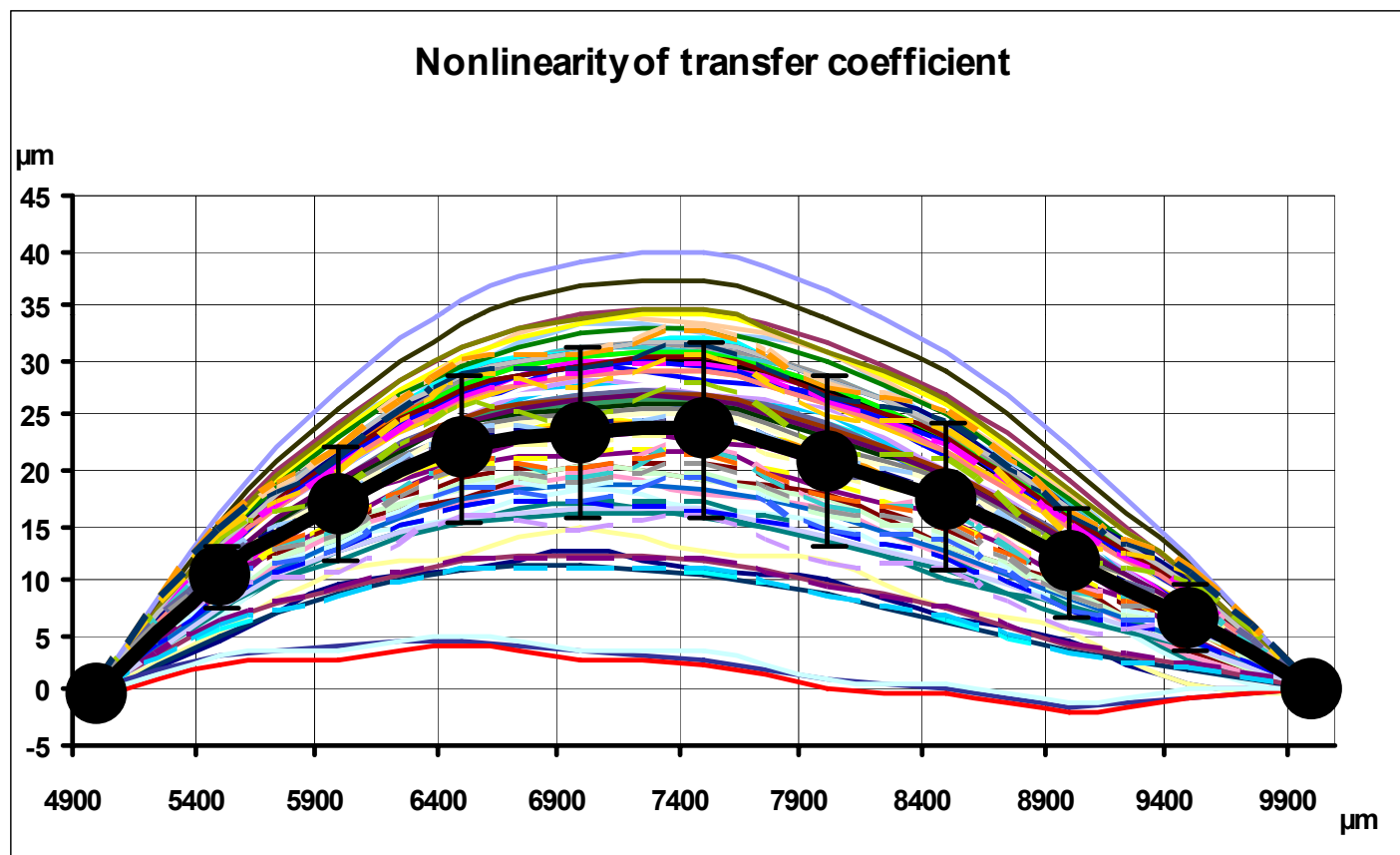

Nonlinearity curves of transfer coefficient for 80 SASE sensors.



NANOBEAM 2008



Nonlinearity of transfer coefficient after interpolation

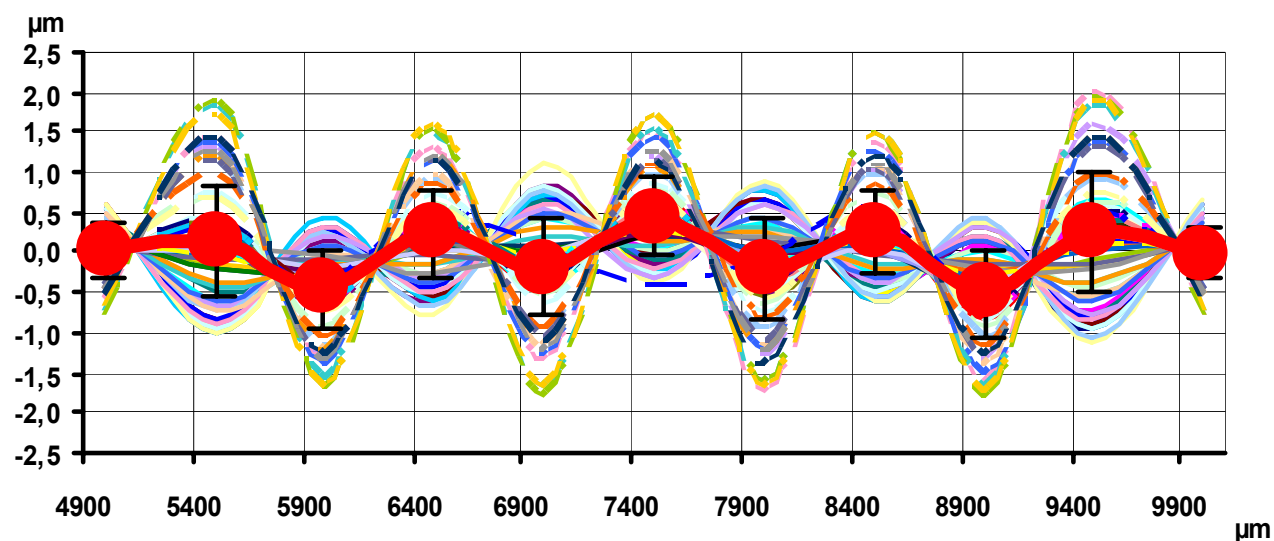

Nonlinearity curves of transfer coefficient after interpolation by the 3rd order polynomial for the SASE sensors.



NANOBEAM 2008



Capacitive level sensors have now only two benefits.

1. Capacitive sensors are more inexpensive. For ultrasonic sensor price of transducer forms considerable part of costs.
2. Capacitive sensors are working during many years. There is a big experience of work with them. Ultrasonic level sensors have not such experience.

So very important question! *“What is reliability of the ultrasonic transducers? How long they can work without essential worsening of their characteristics?”*

The ahead installation of HLS system at LCLS Undulator magnet line promises getting of very interesting experience. It will be the first HLS system consists of two different kinds of level sensors.



NANOBEAM 2008



6. REFERENCES

- [1] Ferry N. Toth and Gerard C.M. Meijer “A Low-Cost, Smart Capacitive Position Sensor”, / <http://ieeexplore.ieee.org/iel1/19/5183/00199446.pdf> ./
- [2] A. Chupyra, M. Kondaurov, A. Medvedko, S. Singatulin, E. Shubin “SAS family of hydrostatic level and tilt sensors for slow ground motion studies and precise alignment” Proceeding of 8th IWAA04, Geneve, 2004.
- [3] <http://www.lantronix.com/device-networking/embedded-device-servers/xport.html>
- [4] M. Shlösser, A. Herty, “High precision accelerator alignment of large linear colliders – vertical alignment”. Proceedings of the 7th IWAA, Spring-8, 2002.
- [5] A. Chupyra, G. Gusev, M. Kondaurov, A. Medvedko, Sh. Singatulin “The ultrasonic level sensors for precise alignment of particle accelerators and storage rings” Proceeding of 9th IWAA06, SLAC, 2006.
- [6] <http://zone.ni.com/devzone/cda/tut/p/id/3346>.



NANOBEAM 2008



Thank you for attention!



A.Chupyra, BINP Novosibirsk,
May 25-30, 2008



NANOBEAM 2008

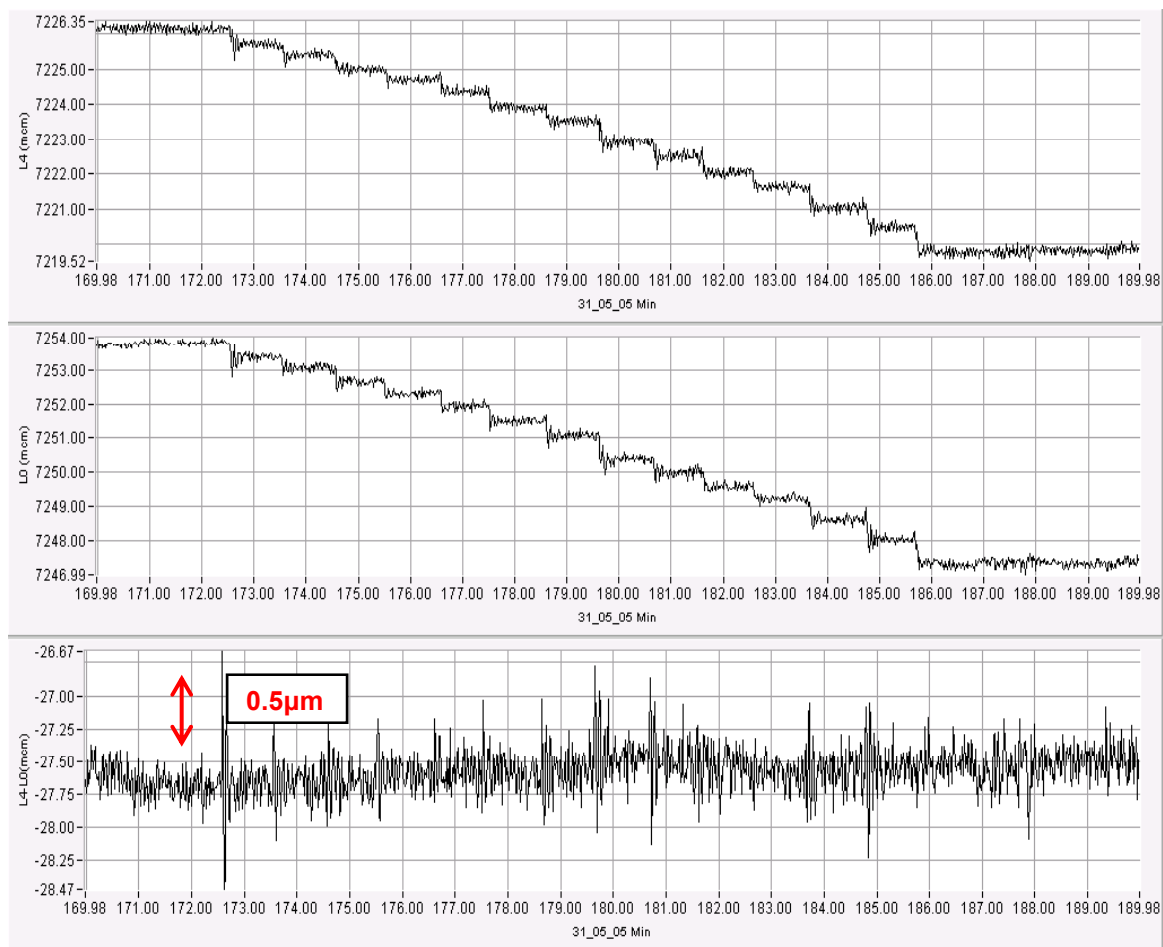

Test of the ULS sensitivity (water drops test). Level steps => 0.5µm

A.Chupya, BINP Novosibirsk,
May 25-30, 2008



NANOBEAM 2008

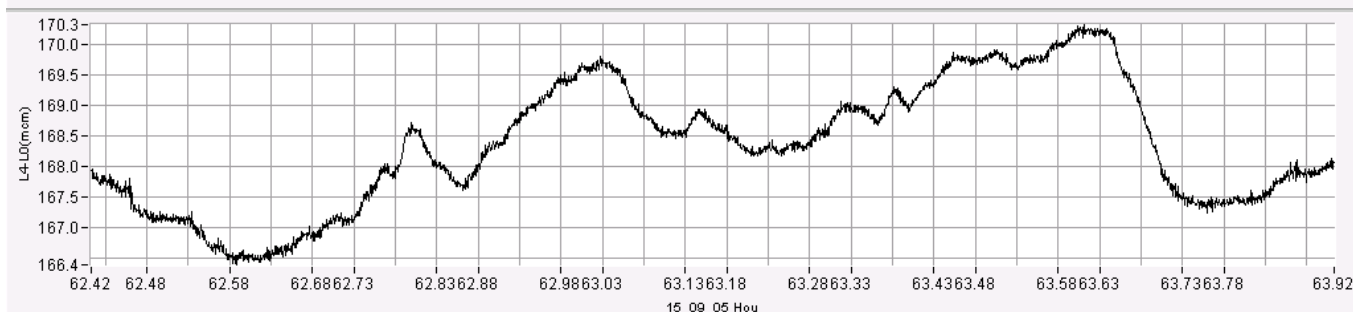
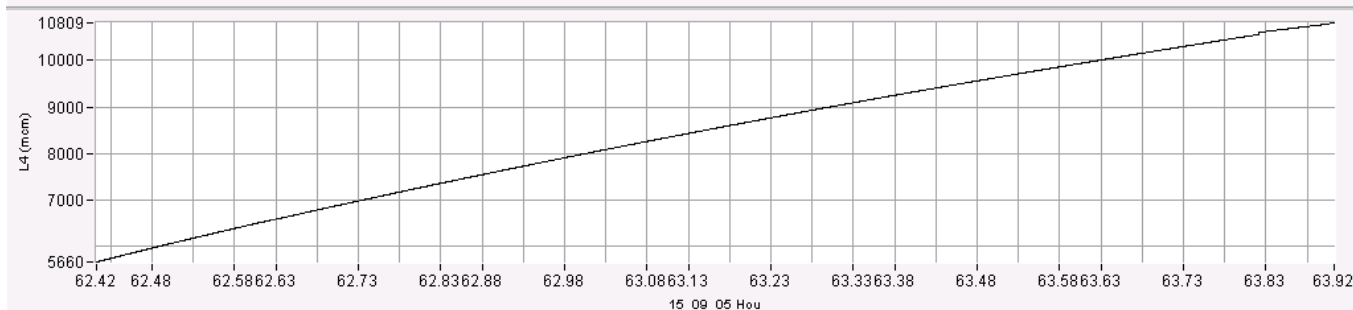
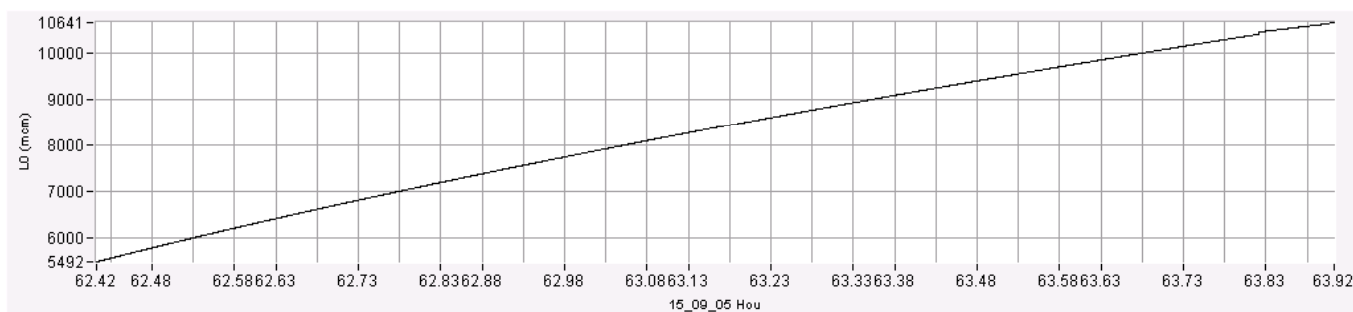

Absolute level increases
More than
5mm

Level difference
Less than
4 μ m

Checking of the accuracy (water flew in)

A.Chupyra, BINP Novosibirsk,
May 25-30, 2008



NANOBEAM 2008



The sequence of operations of the electronics of the ULSE

- After power “ON” the Microcontroller begin fulfillment of program, placed in its internal memory. The microcontroller makes measurement cycle once on 10 ms.
- It forms start pulses for the Transmitter and TDC.
- The Transmitter generates electrical pulse for Transducer.
- The Receiver takes the reflected signals and sends them to the Comparator.
- The Comparator transforms analogous signals into digital pulses.
- TDC measures time intervals between the start pulse and the pulses coming from the Comparator.
- The Microcontroller gets digital codes from TDC and prepares them for the next transmission to PC computer.
- Number of cycles and clock frequency of PC is determined by system and size of the ULSE memory.
- The Microcontroller also can measure temperature of ULSE vessel and accordingly temperature of water inside the vessel with help of temperature probe and inboard ADC. Temperature measurement resolution is about 0.1 C.



NANOBEAM 2008



Each ULSE vessel is equipped with:

- the piezoelectric transducer of Krautkramer H10KB3 type;
- the temperature sensor ;
- electronics box.

The electronics has:

- fast and precise Time-to-Digital converter (TDC)
- microcontroller
- built-in PoE interface
- DC/DC converter

There are two types of ULS prototypes:

ULS-PR => with Panametric Transducer and RS-485 Interface

ULS-KE => with Krautkramer Transducer and *PoE* (Power – over – Ethernet) interface



NANOBEAM 2008

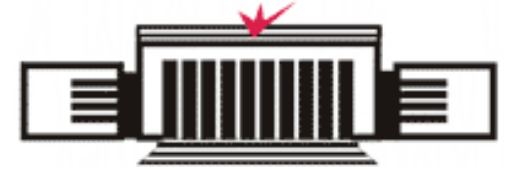

Near zone => Far zone

- The ultrasonic beam is more uniform in the far field zone
- The transition between these zones occurs at a distance $N \rightarrow$ "natural focus" of a flat (or unfocused) transducer.
- This near/far *distance N is very significant*: This area just beyond the near field where the sound wave have maximum strength.
- *Optimal measurement results will be obtained when reflective surfaces are close to N area:*
- $N < d < 2N$
- *This requirement determines the minimal distance from transducer to target surfaces.*



NANOBEAM 2008



Some explanations about Comparator and it's function

Comparator converts analogous signal of reflected oscillations into the digital “ON/OFF” form.

To avoid the dependence of time measurements from reflected pulse amplitude we had applied the “zero level” comparator.

In Comparator the reflected analogous signal, looking like a short bunch of oscillations, enters to the gate.

Gate has predicted time position and pulse duration. It has raw comparator. Main Comparator has **zero reference level and sufficiently high gain.**

Goal is to fix the *“first positive pulse after first negative pulse with sufficiently large amplitude”*.



NANOBEAM 2008



VARIANTS OF MECHANICAL DESIGN

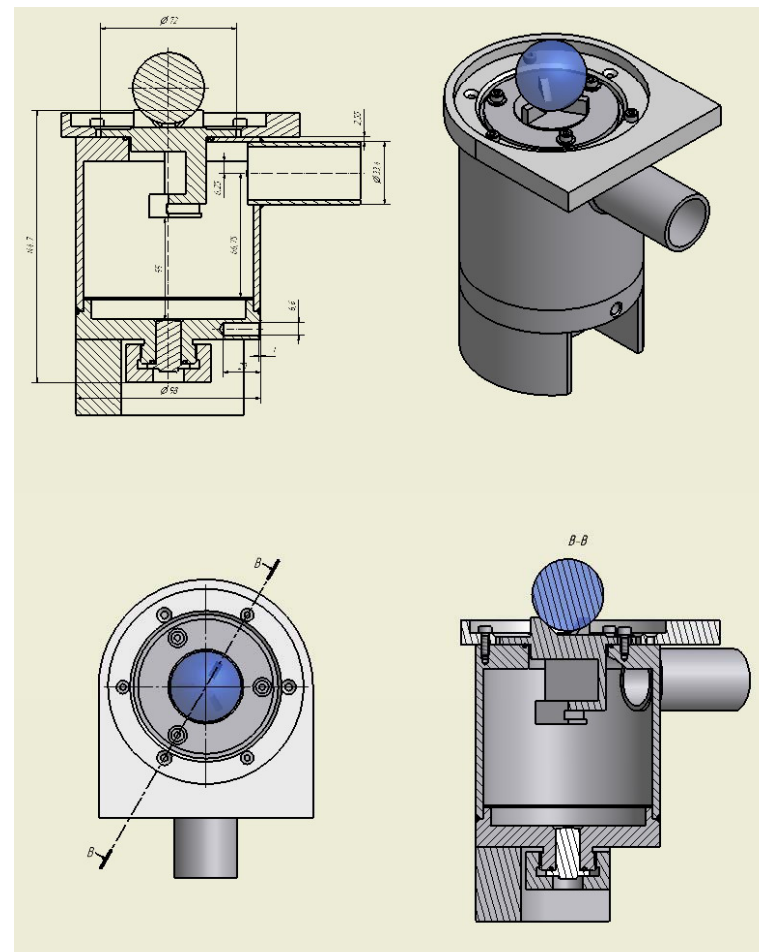
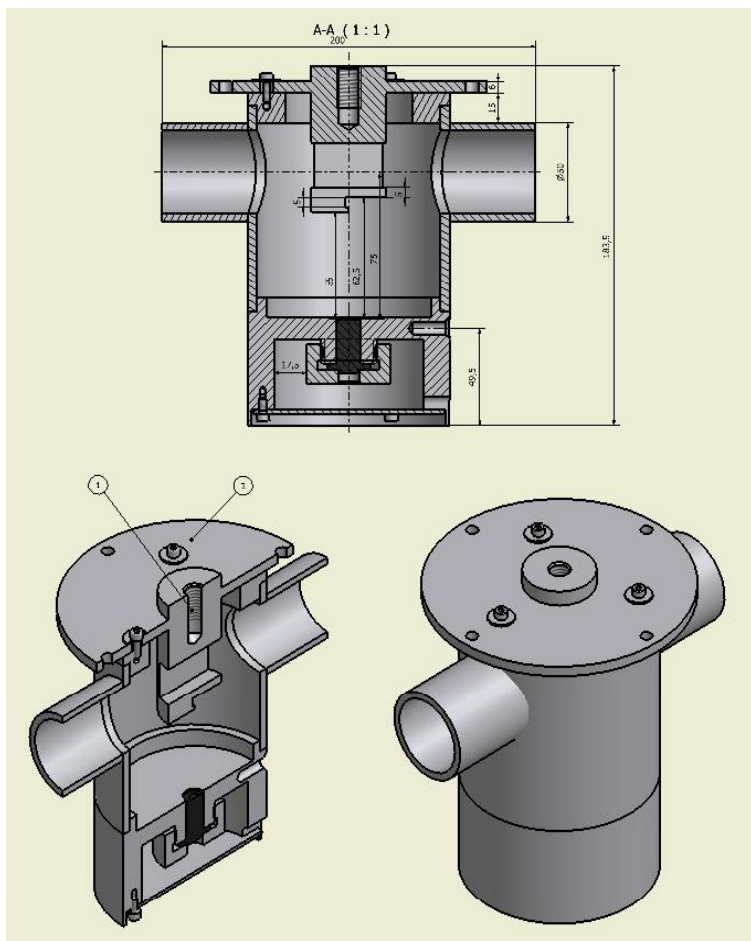

A.Chupyra, BINP Novosibirsk,
May 25-30, 2008



NANOBEAM 2008



Time interval measurements

- The transducers with as high as possible value of operating frequency. We choose **5MHz and 10MHz**;
- **One clock of “Start”** for all (three) time intervals to be measured
- **“Zero level”** comparator to fix the arrival time of the reflected pulse;
- **TDC-GP1 type** of the Time-to-Digit Converter with highly precision measurement function.
- **Microprocessor based electronics for each Sensor** to make necessary individual calibrations and processing with signals: storing of measurement results, calculation and averaging them.



NANOBEAM 2008



Unfocused immersion transducer parameters

Table 1

Parameter \ Transducer Type	Units	V310-RU Panametric	H10 KB 3 Krautkraemer
Central frequency	MHz	5.0	10.0
Bandwidth	%	>70	<40
Transducer diameter	mm	6.35	5.0
Beam spread angle $\alpha/2$	Degree (rad)	1.365 (0.0243)	0.884 (0.0154)
near/far distance N	mm	33.6	41.7



NANOBEAM 2008

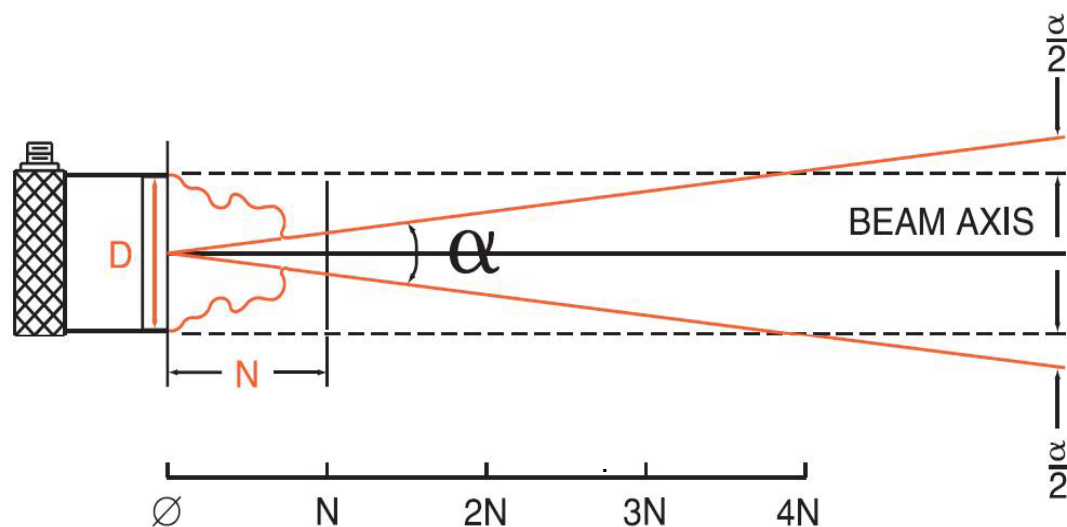

A simplified view of a sound beam for flat transducer

$$\sin(\alpha / 2) = 0.514 \cdot \lambda / (D \cdot f)$$

(The coefficient corresponds to - 6dB intensity decreasing)



NANOBEAM 2008



TDC-GP1 of ACAM Corp.  *Time-To-Digital Converter* -- central chip of the ULS electronics.

The main features of TDC-GP1:

- 2 measuring channels with up to four independent “Stops” per channel
- Typical resolution of 250ps;
- Typical resolution of 125ps for mode with one channel;
- Nonius method in one channel mode. The result is the sum of different finecount and coarsecount counters;
- 4-fold multi-hit capability per channel, double pulse resolution typ. 15ns retriggerable;
- 2 measurement ranges => a: 2 ns -7.6 μ s => b: 60 ns-200 ms;
- The 8 events of the two channels can arbitrarily be measured against one another;
- Variable edge sensitivity of the measuring inputs;
- Internal ALU for the calibration of the measurement result.
- Extremely low power consumption.



NANOBEAM 2008



Nonius Mode of TDC-GP1

The mode of TDC operation “Measurement Range 2” :

Only 1 channel is available with :

4 possible STOPS in normal resolution (250 ps)

3 possible STOPS in high resolution (125 ps)

*In our case we have to measure three time intervals
(three Stops against one Start).*



NANOBEAM 2008



Since 2001 year BINP took part in development and fabrication of Hydrostatic Level Sensors in the network of team-work with FNAL and SLAC. At the beginning BINP developed capacitive HLS sensors and then in 2005 ultrasonic HLS sensors.

During last 7 years more then 200 sensors of both type were fabricated and delivered to FNAL and SLAC.



NANOBEAM 2008



BINP HLS Sensors installed at SLAC (August 2006)

*Installed on site at SPEAR3 (5 Sensors, 1 Year)
and Babar (1st Generation, 6 Sensors, 3-4 Years),
Sector 10 (4 “first article” sensors, 2 months)*