

SCRF Meeting

DESY, January 18, 2008

Blade Tuner Status and Plans

Carlo Pagani

University of Milano and INFN Milano

Slim Blade tuner tested in CHECHIA

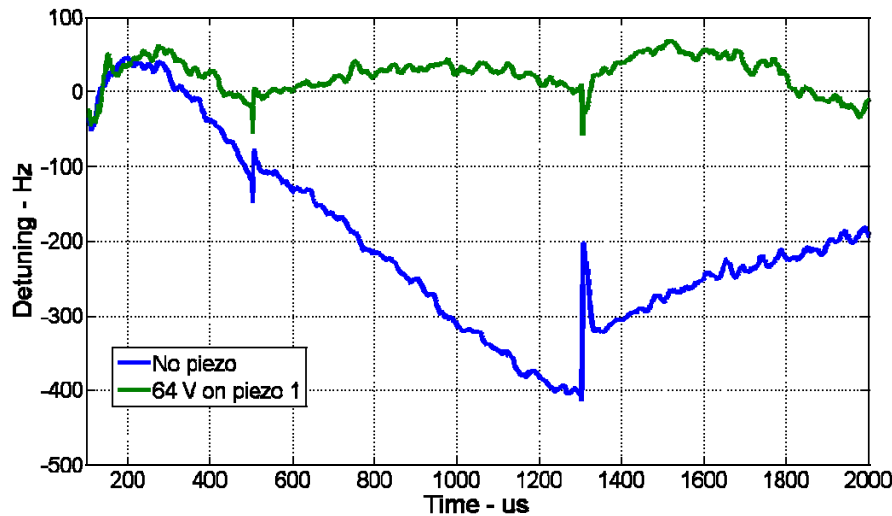

Final version
 with revised
 He tank and
 end groups,
 proposed for
 ILC-HiGrade
 and FNAL 2°
 ILCTA module

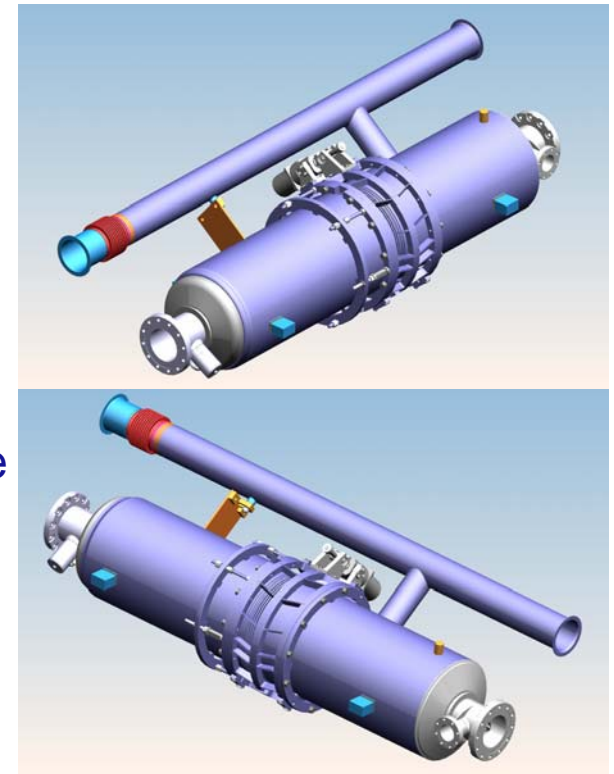

300 Hz of LFD, during the RF pulse flat top, have been compensated at $E_{acc} = 23$ MV/m, driving only one of two installed piezo actuators with 64 V, less than 1/3 of the nominal maximum driving voltage (200 V @ RT).

Lessons from the CHECHIA Tests

- **What we learned:**

- As anticipated the mechanical weakness does not affect compensation
- The mechanical weakness only demands a 20-30% extra stroke to the piezo to compensate for a 20-30% larger detuning
- The piezo stroke has large margin. At 23 MV/m 64 V were required on a single piezo of 40 mm length. The system is designed for up to 70 mm piezos, driven to up to 200 V. If the two piezos are operated in parallel the effect is twice. The safety factor at 31.5 MV/m is > 3 or > 5 (40 or 70 mm)

- **What we decided to improve:**

- Mechanical stiffness of the Tuner/He Tank system to fulfill the pressure vessel certifications: 4 bar absolute. This will also further increase the already large compensation margin.
- Mechanical details for safe assembly and safe operation in the anticipated extreme conditions that could be expected during the cool-down.
- The marginal while unpleasant mechanical hysteresis that was observed

Improved design to fulfill regulations

- 8 improved piezo Blade-Tuners have been ordered to be delivered by April this year.
- After tests they will be delivered to Fermilab for their integration in the 2° ILCTA cryomodule (to be delivered by INFN by September)
- They should represent the baseline design for the 24 complete cavities funded by EU in the framework of the FP7 contract: ILC Hi-Grade, to be delivered by end 2010.

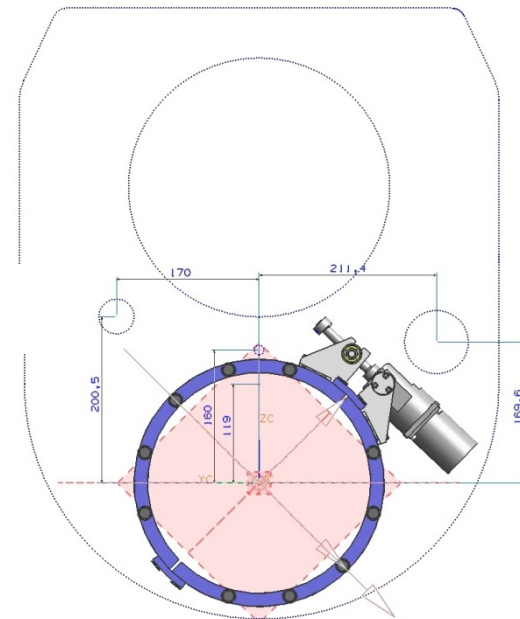
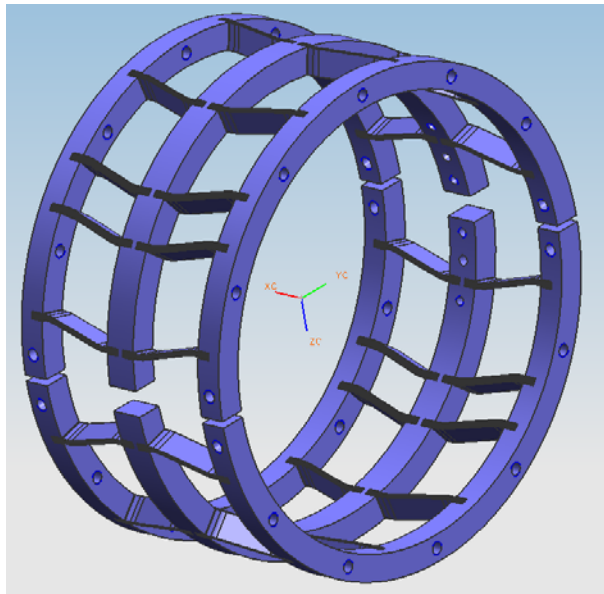

Improved and simplified Helium Tank



Present TTF dressed cavity

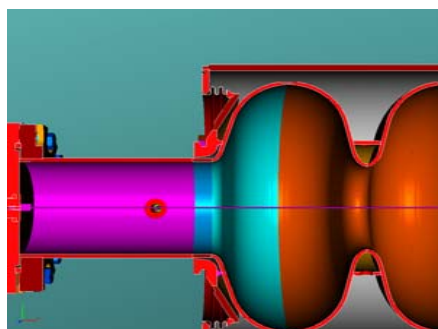

X Lateral tuner

X Coaxial tuner

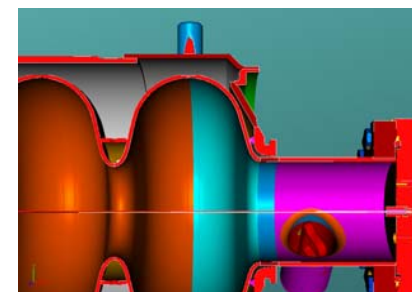

Design reviewed for Blade Tuner

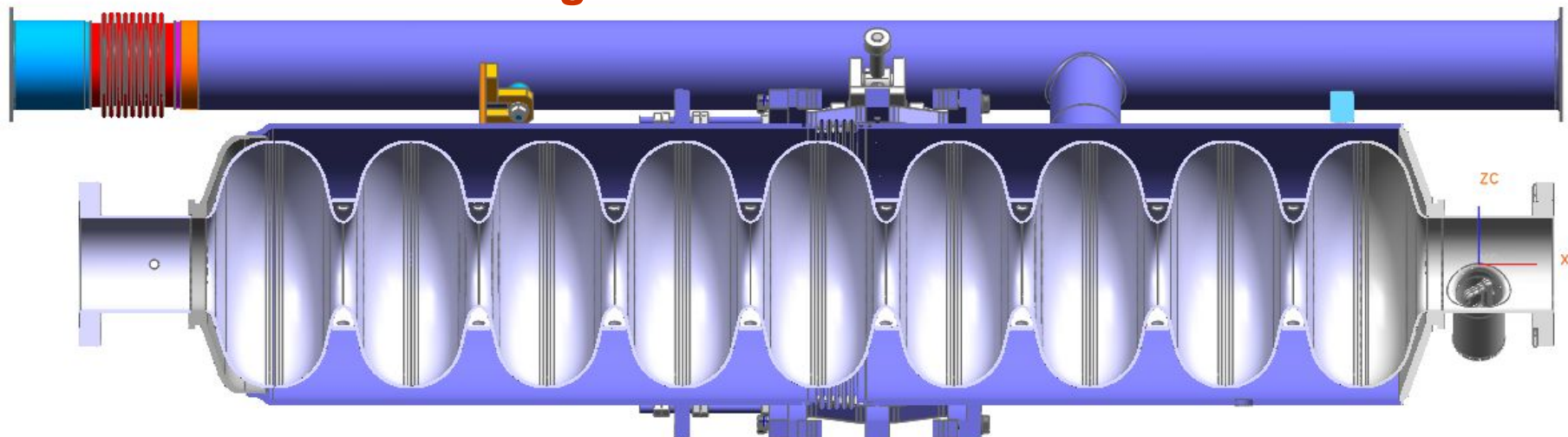

Tuner / He Tank Goals

- Fulfill all the specifications, ILC and XFEL, with margin:
 - From pressure vessel requirements
 - From Lorentz force and microphonic compensation
- Bring the total cost to be lower then that of the present XFEL design

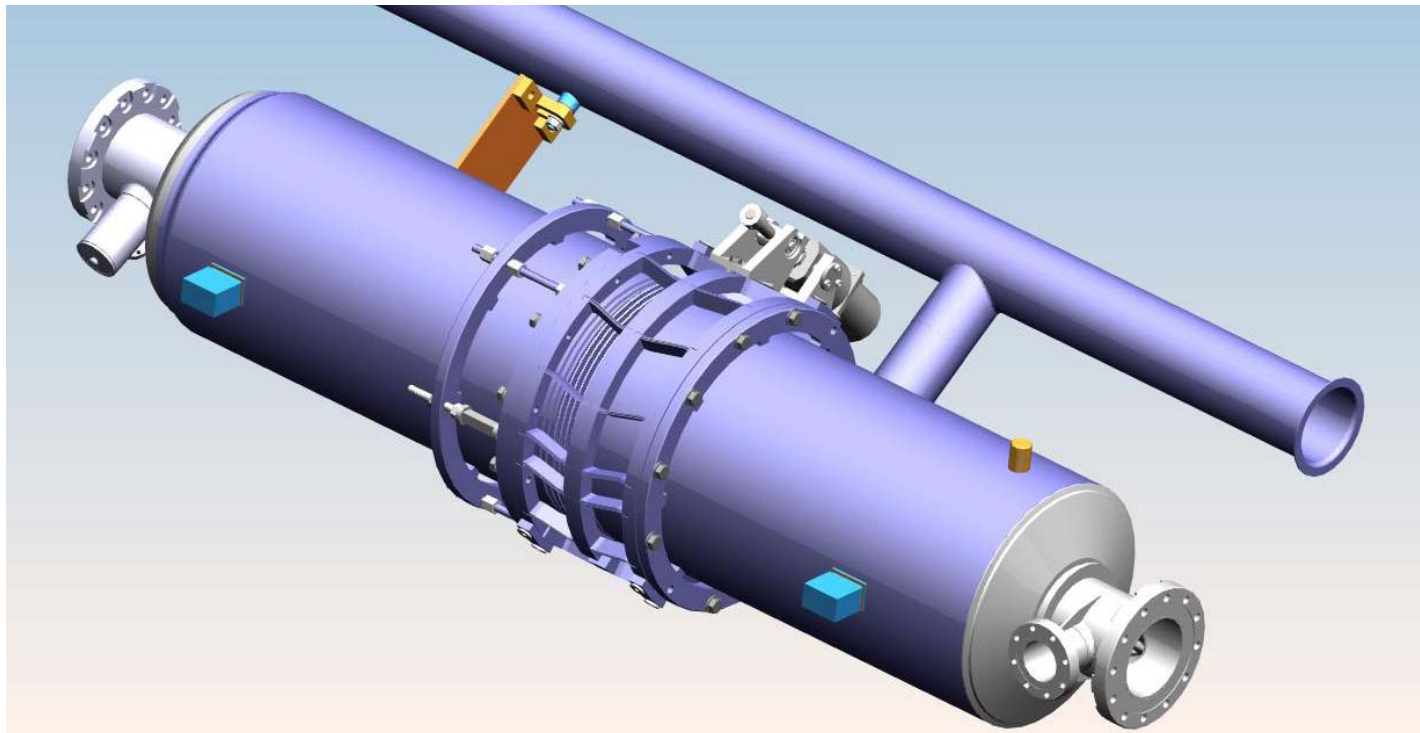

Further experience from protons

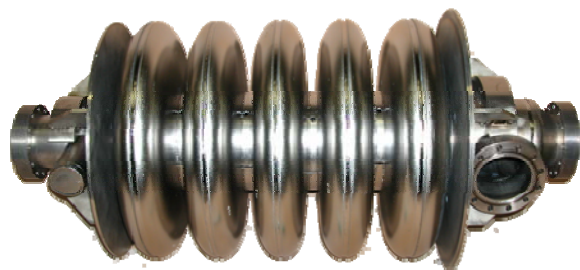

Mag shield internal to HT

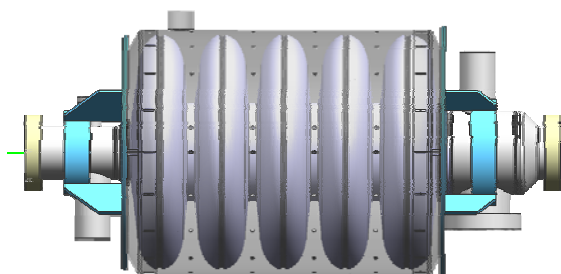

T18 or EB weld to T1 Term

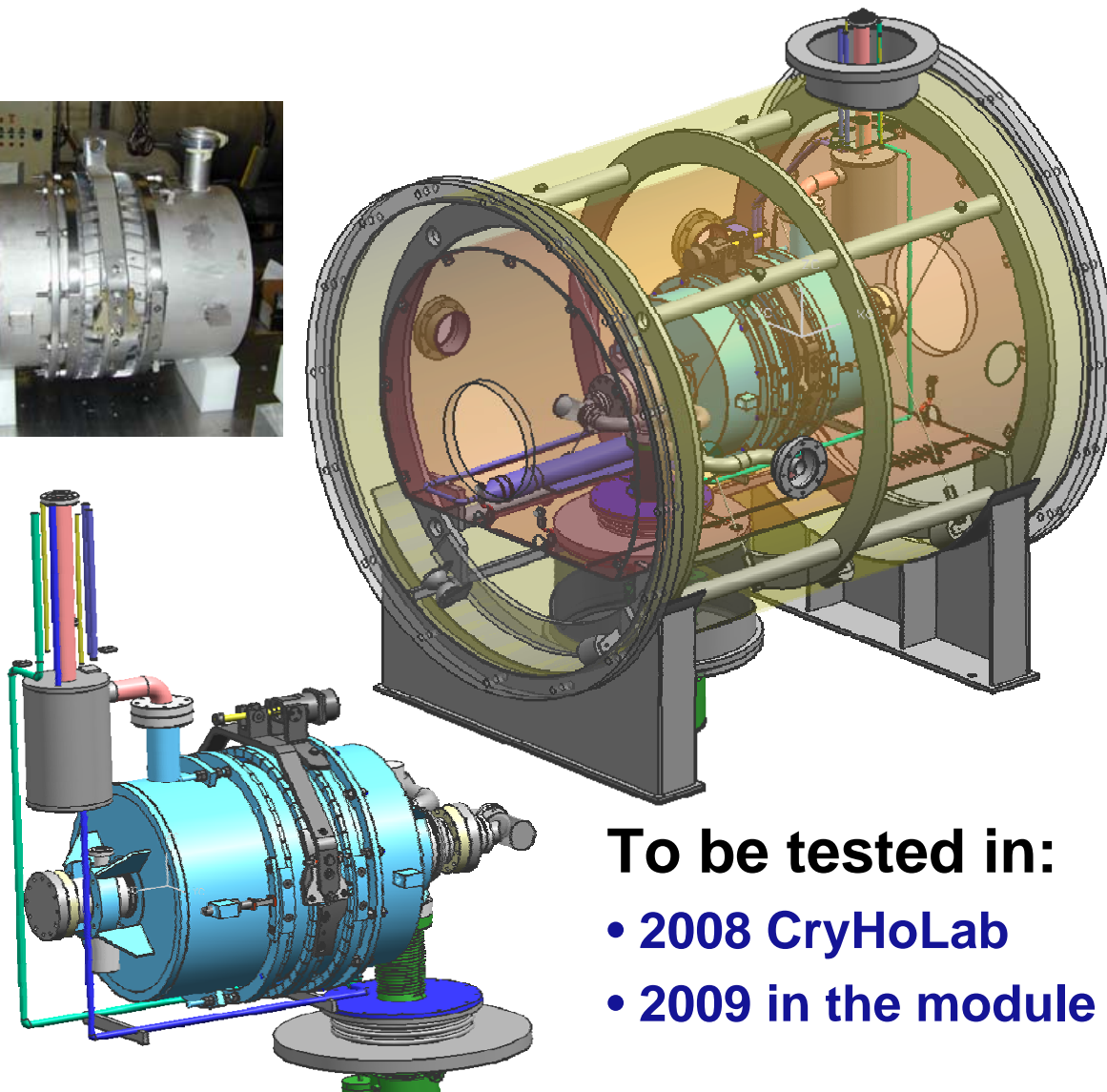
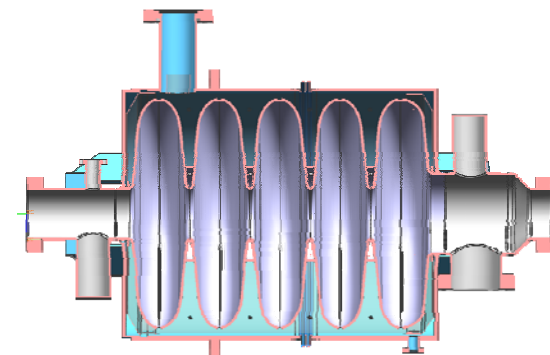

- To be tested in:**
- 2008 CryHoLab
 - 2009 in the module