



Silicon Pixel Tracker (SPT)

Chris Damerell (RAL)

Update from Sendai talk by Konstantin Stefanov



Motivation – why a new tracker concept?

- Goal is to develop a tracking system of unprecedented **transparency** ($\sim 5\% X_0$) so that nearly all photons down to 7 degrees θ_p will convert in the ECAL
- **Maximise performance** by using pixels, which provide unambiguous space points on each layer. 5 layers of barrels or endcap disks will provide considerable redundancy
- **Maximise transparency** by sacrificing timing information, since that can be provided by the ECAL. Basic principle is to strip out all information that isn't strictly necessary, and which costs in material in front of the calorimetry
- Advantages for physics will depend on detailed comparisons with the competition, once we have realistic material budget estimates for all options (including this one, all of which have considerable uncertainties)

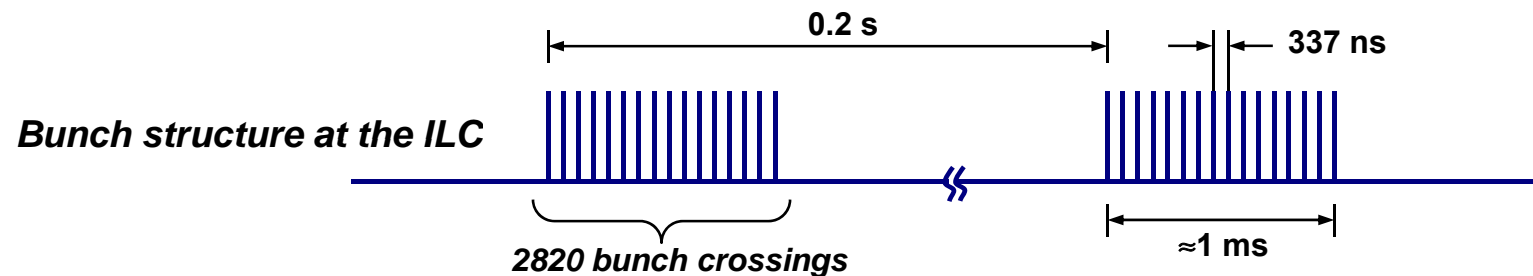

- Detector options:
 - Single bunch timing
 - Time-slicing of train (eg at $50 \mu\text{s}$ intervals, 20 slices)
 - Integrate signals through train, with relaxed readout during the inter-train period
- No 'right answer'. There's an advantage in time integration, namely *reduced power*. Fine sensor granularity may compensate for pileup of background from multiple bunch crossings
- Lower peak power permits reduced cable plant, hence reduced material budget. Avoiding pulsed power has further electro-mechanical advantages
- There has been a successful history of exploiting tradeoffs between granularity and time resolution in ACCMOR and SLD vertex detectors
- Contrast LHC, where single bunch timing is mandatory, but one pays a heavy price in material ...

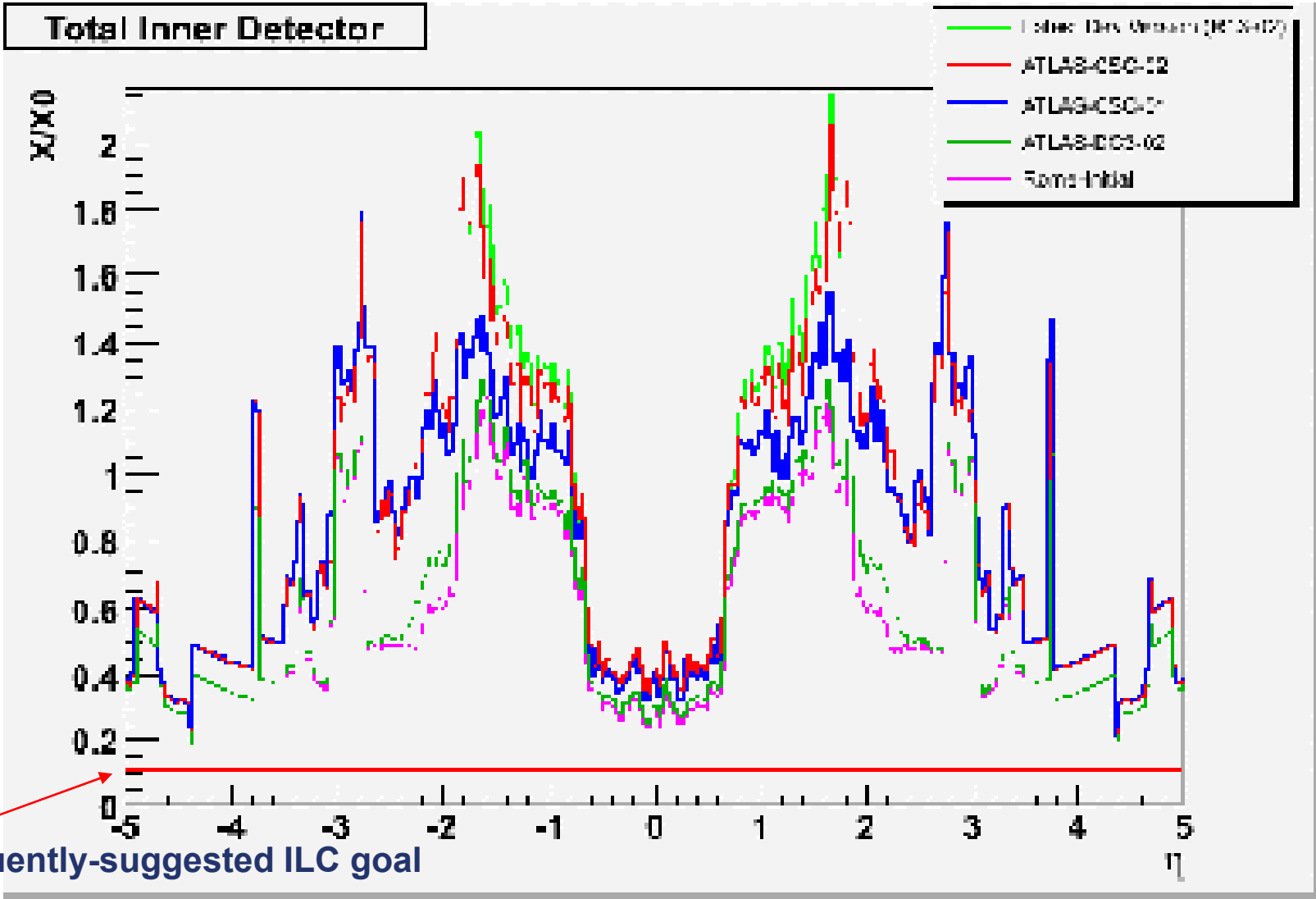

- A pixel tracker, being free of ghost hits, has a proven record for extremely high pattern recognition efficiency compared to microstrips, in high multiplicity jet-like events (ACCMOR Collaboration, mid-1980s)
- Total thickness of this **standalone tracking system** was 0.2% X_0

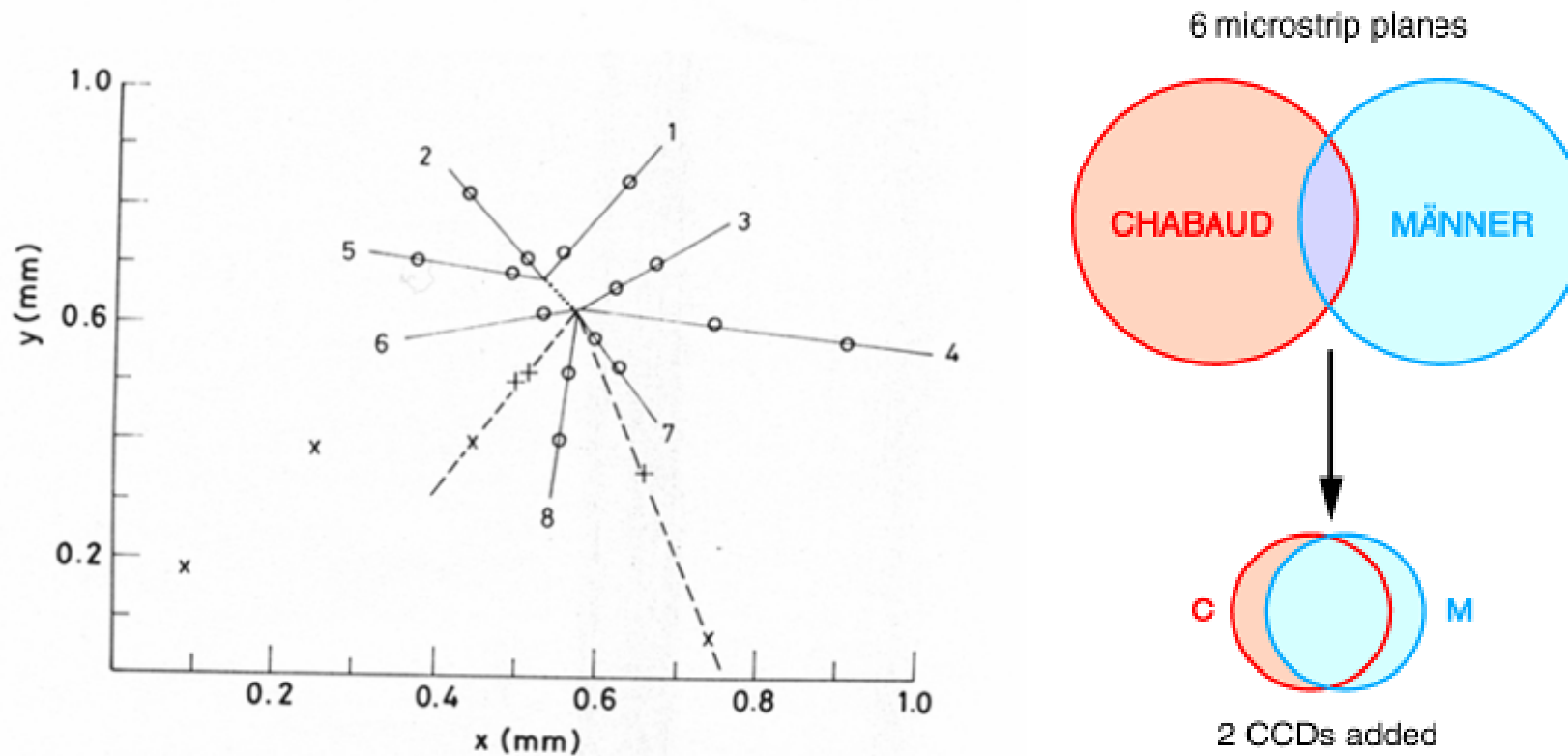

- We suggest that 5 layers of pixels (50 μm square) would have excellent standalone track reconstruction efficiency, even in the core of high energy jets, where 5 layers of single-sided unidirectional microstrips may be struggling
- Given PFA goals, there are clear advantages in robust standalone track-finding separately in the vertex detector and tracking systems
- However, 'standard' MAPS devices would consume far too much power, so material budget would be blown away by the required cooling system
- If one can afford to integrate the background through the bunch train, one can adopt an appropriate pixel technology, exchanging high pulsed power for low continuous power, with consequential benefit to material budget (cabling and mechanics)
- Integrating through a train causes **no problems** to the 'real' track finding: density of extra hits within a jet is negligible
- What is less clear is the impact on track finding of the salt-and-pepper background that populates the detector. Risk of an unacceptable load of **fake tracks**. Thanks to Marcel Vos for eloquently alerting us to this in Sendai

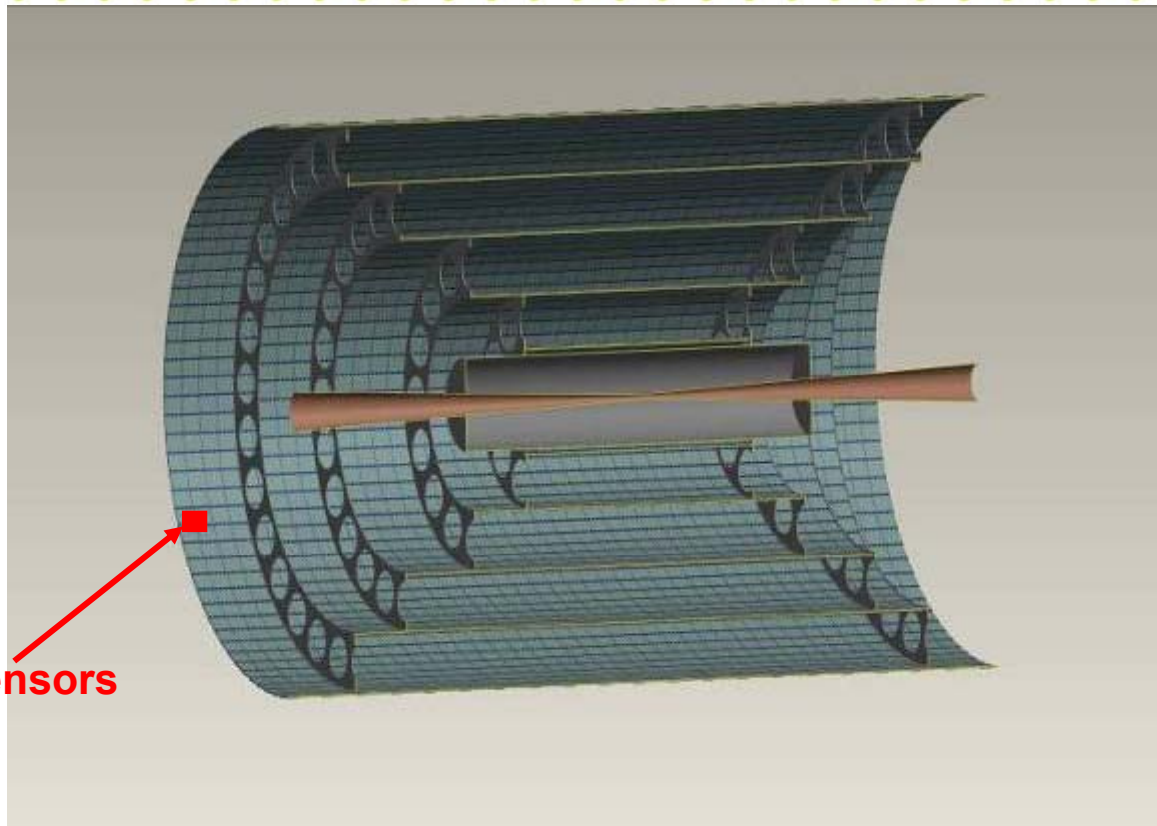

one of 11,000 sensors
8x8 cm²

- SiC foam support ladders, linked mechanically to one another along their length
- 5 **closed cylinders** (incl endcaps, not shown) will have excellent mechanical stability
- ~0.6% X_0 per layer, 3.0% X_0 total, over full polar angle range, plus <1% X_0 from VXD system (goal)
- 30 Gpixels, in line with trends in astronomical wide-field focal plane systems by 2020



End view of 2 barrel ladders ('spiral' geometry)

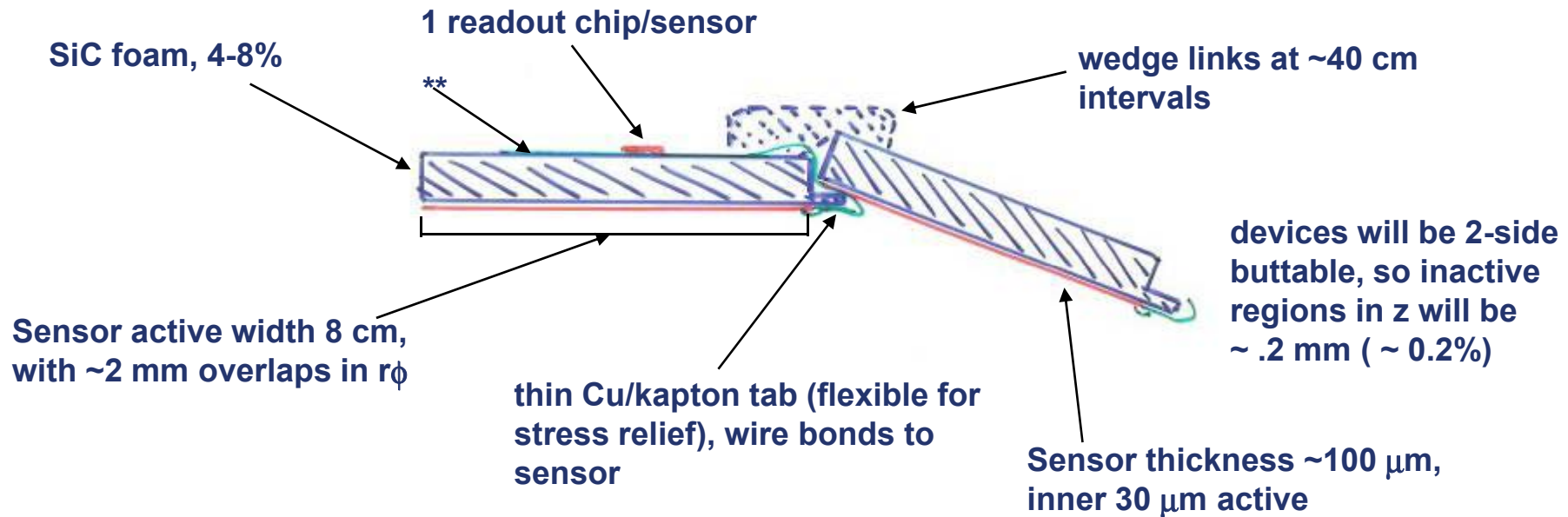

** single layer Cu/kapton stripline runs length of ladder, double layer in region of tabs (~5 mm wide) which contact each sensor. Single Cu/kapton stripline runs round the end of each barrel, servicing all ladders of that barrel

Bottom line: potential material budget ~0.6% X_0 per layer, but much design and R&D needed to establish mechanical stability, including shape stability wrt push-pull operations (taking advantage of stress-free 3-point kinematic mount)



Backgrounds in silicon tracker

- Thanks to Takashi Maruyama, Norm Graf and John Jaros for help with this
- Takashi has calculated beamstrahlung-related and 2-photon backgrounds, both charged tracks and photon conversions
- 80% of hits are due to photons emitted from the BEAMCAL region, converting in the material of the tracker
- These photons are mostly of energy 0.1-1 MeV, with a peak at 0.51 MeV from positron annihilation in the BEAMCAL
- Using EGS, Takashi studied the conversion process in the detector, mostly Compton scattered electrons which generate typically 1-10 hits in a tracker layer, which he idealised as 300 μm Si. In our case, this probably over-estimates the effect, but not by much

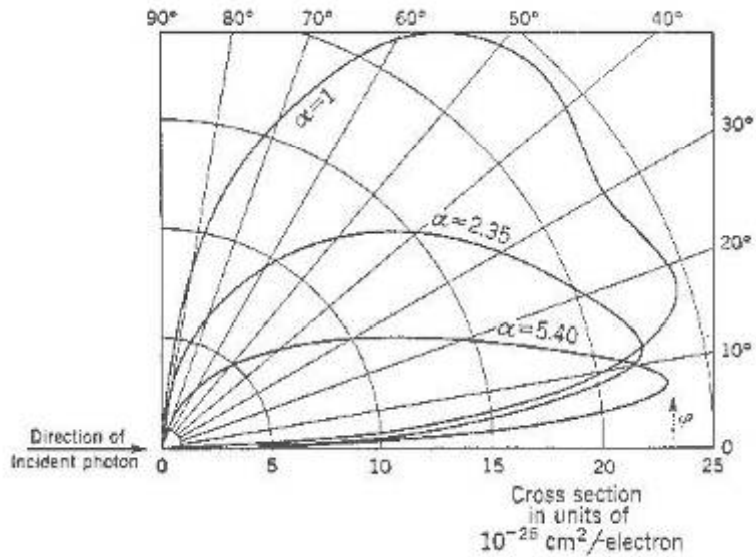

Evans, p 691: photon energies 0.51, 1.2 and 2.76 MeV; electron angular distns

barrel ladder, $r\phi$ view

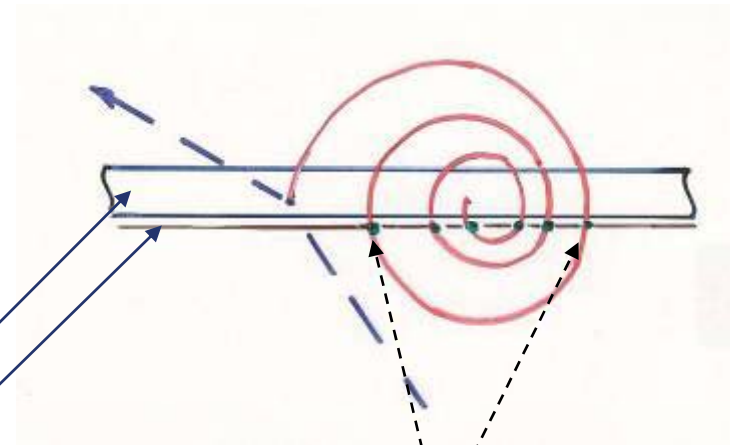

~0.5% X_0 support foam and Cu-kapton

~0.1% X_0 silicon, 30 μm active on inner surface

6 hits, stepped in z, each hit indistinguishable from min-l

- Total hit density ranges from $2.5/\text{cm}^2/\text{train}$ (layer 1 barrel) to 1/10 of that (layer 5 barrel) – occupancies in SPT are everywhere $< 10^{-4}$ ‘negligible’, or so we thought
- For the forward disks, densities exceed $600/\text{cm}^2/\text{train}$, so pixels with short sensitive windows will be needed. Fortunately, area to be covered is small

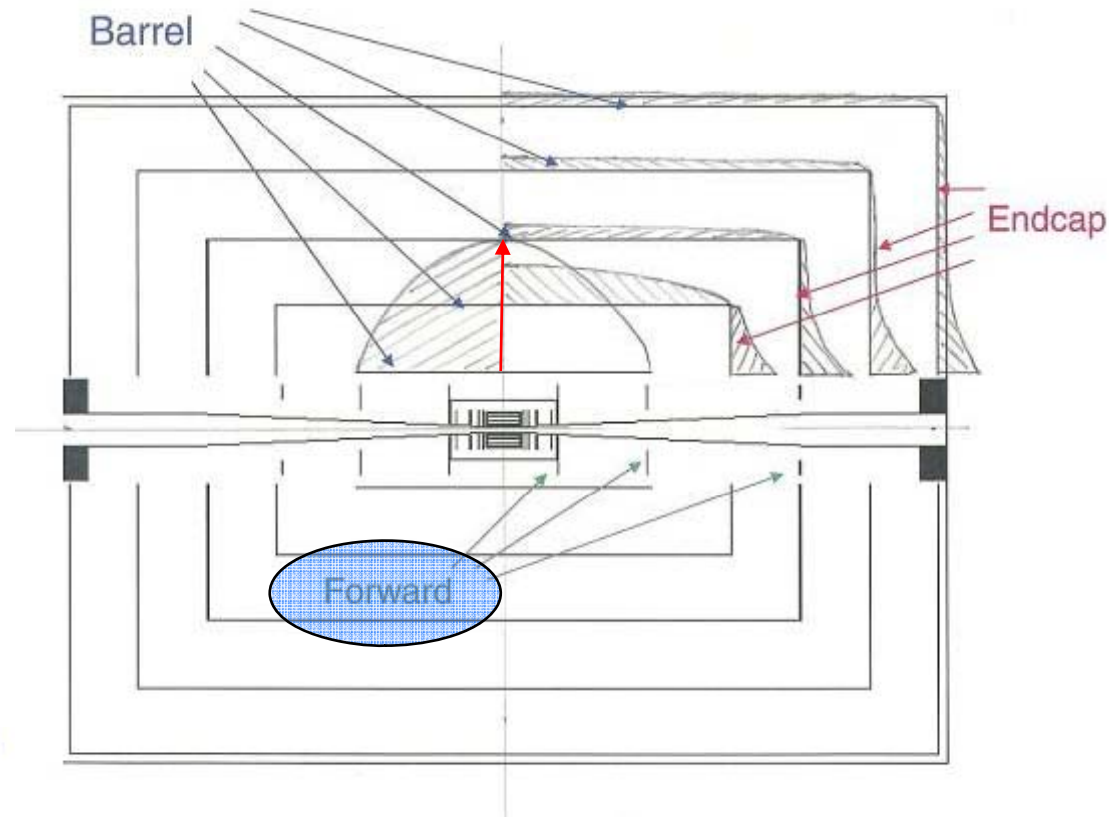



Possible track-finding strategy

- First deal with tracks having approximate IP constraint – prompt tracks and B and D decay products
- [Use Garfield approach for K-shorts and lambdas, as well as photon conversions and secondary interactions. A key point is that the latter will be considerably suppressed by the reduced material budget]
- Work from ‘outside’ in, where outside means seed layer 5, 4, 3, 2, 1, down to a p_T limit $p_T(\text{crit})$ for which track in r - ϕ view is at 45 degrees to the layer surface
- | Layer | $p_T(\text{crit})$ (GeV/c) |
|-------|----------------------------|
| 5 | 1.33 |
| 4 | 1.05 |
| 3 | 0.77 |
| 2 | 0.49 |
| 1 | 0.21 |
- Particles with p_T below 200 MeV/c are to be found as curlers in the forward tracking detectors. This should be OK for those which originate within the VXD volume – but challenging for the small number born beyond (from long-lived B and D decays).

Search area on Layer 4

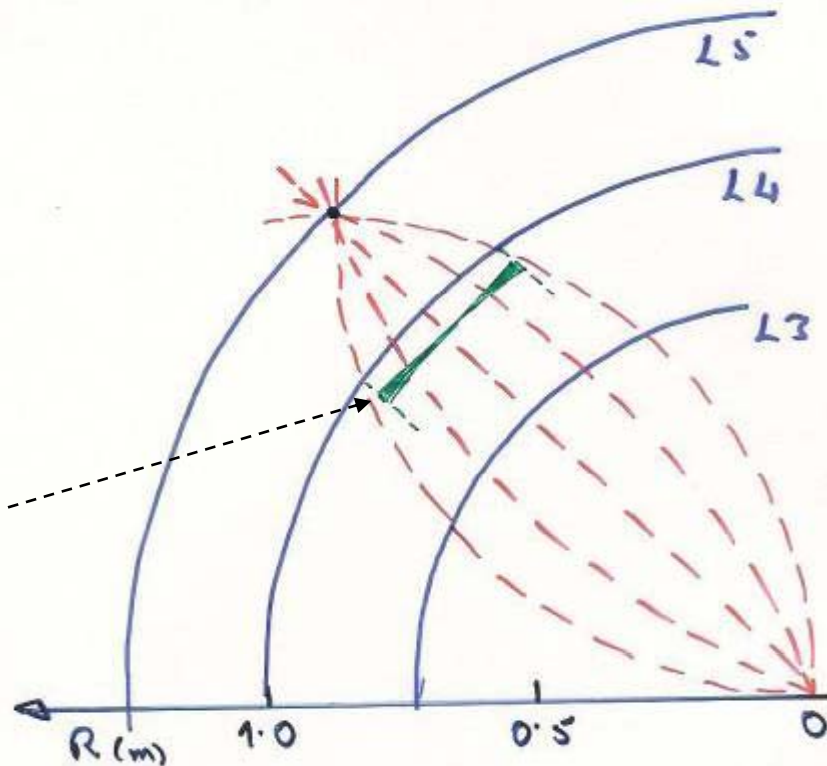

- Start with seed layer 5, and extrapolate each hit as a track candidate to layer 4, respecting the IP constraint and the $p_T(\text{crit})$ limit
- Multiple scattering implies a bow-tie profile for acceptable layer-4 links; $\pm 3 \sigma$ limit delivers on average 0.9 candidate tracks (looks pretty bad at this stage!)
- However, we can now extrapolate tracks of increasingly well-defined momentum to layer 3, 2, 1 with precision limited mainly by multiple scattering, and end up with well below 1 fake track per event, from 52000 seeds in layer 5



- Extrapolation outwards to ECAL cleans up the fake tracks, plus the out-of-time background charged particles, which mostly come from 2-photon background
- This step won't be perfect – a fake track may point to a genuine ECAL cluster, but we appear to be talking about cleanup of a small number of fakes, and a matching ECAL cluster does need to be charged and compatible both in position and direction with the track candidate
- Procedure becomes less beautiful as seed layer is stepped inwards to pick up lower- p_T tracks, but **even the lowest momentum particles end up in the forward ECAL for validation**, so this approach probably remains robust
- Same procedure works for the endcap disks, with $p_T(\text{crit})$ defined by the radial position of the seed hit. Multiple scattering effects are generally reduced (fewer cases of extreme obliquity)



Technology options

- Conventional CCDs can be used wherever full train integration is permissible. Availability of 30 Gpixel system with 8x8 cm² devices on timescale of 2020 is assured – driven by dark energy and other wide-field camera systems in astronomy
- Cost is expected to be ~\$30M, far higher than microstrips, so a serious performance comparison (particularly of PFA) will be needed before carrying this forward
- If finer time slicing is required (10 to 100 sensitive windows per train) the ISIS technology looks promising. Availability and yield of 8x8 cm² devices is not yet established, but there is time enough for that
- With either option, slowly step through all 11000 devices ladder by ladder for **relaxed readout of undisturbed signal charge** from up to 100 time slices during the 200 ms, with low and constant power dissipation. Estimate for the CCD option is 600 W total power, dissipated steadily while running – well within the capability of gentle gas cooling



Conclusions

- Silicon pixel tracker with signal integration through the bunch train looks promising
- If it works, it should deliver a tracking system with extremely high performance and very little material in front of the calorimeter
- The technology is being developed anyway, for multi-Gigapixel focal plane arrays in astronomy
- Low level of fake tracks and background charged tracks can be efficiently suppressed by demanding position/direction match to an on-time charged ECAL cluster
- Needs a serious simulation of track reconstruction, not just back-of-envelope
- Still need Garfield (or equivalent) to handle non-IP tracks, viz. K-shorts, lambdas, and the greatly reduced incidence of photon conversions and secondary interactions

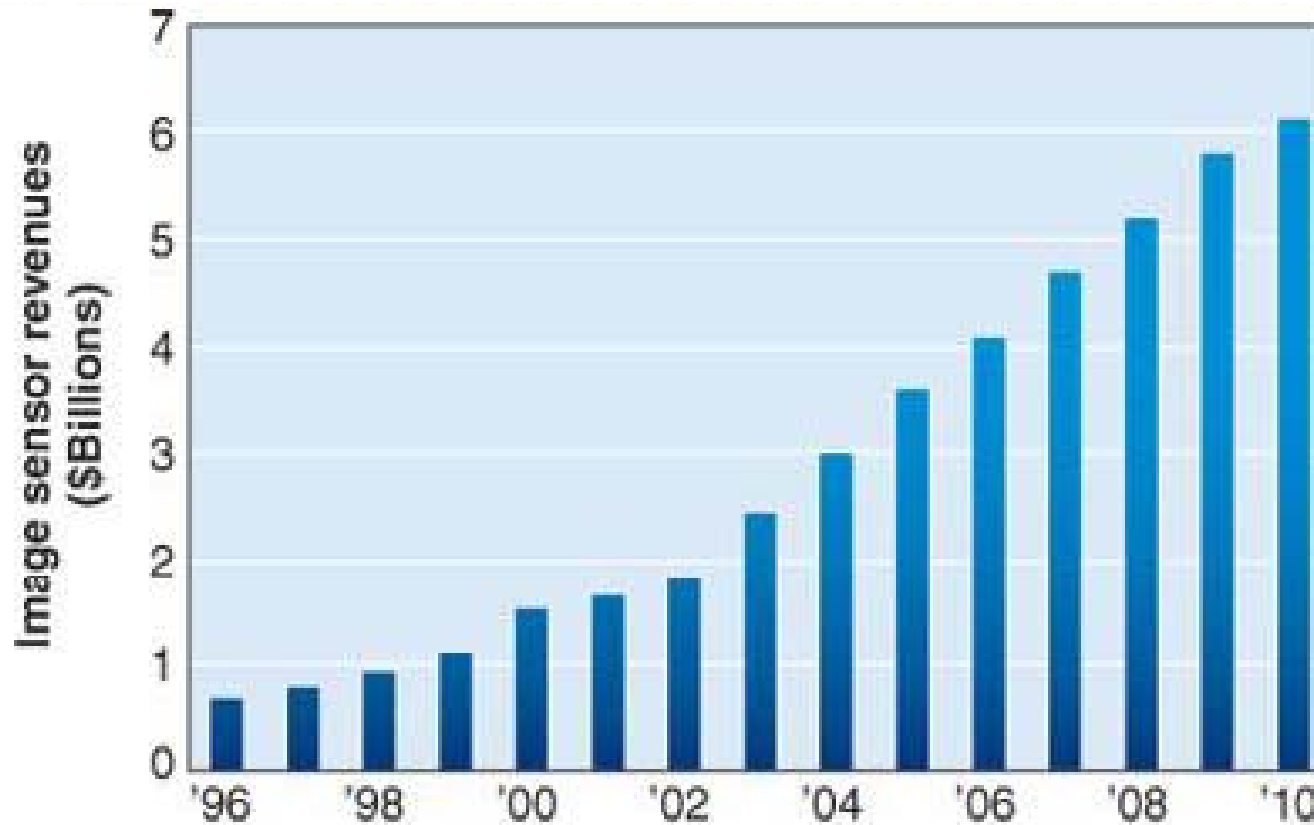

As with developments in microelectronics, we particle physicists are small fish in a very large pond, in which the pace of developments is rapid



Backup

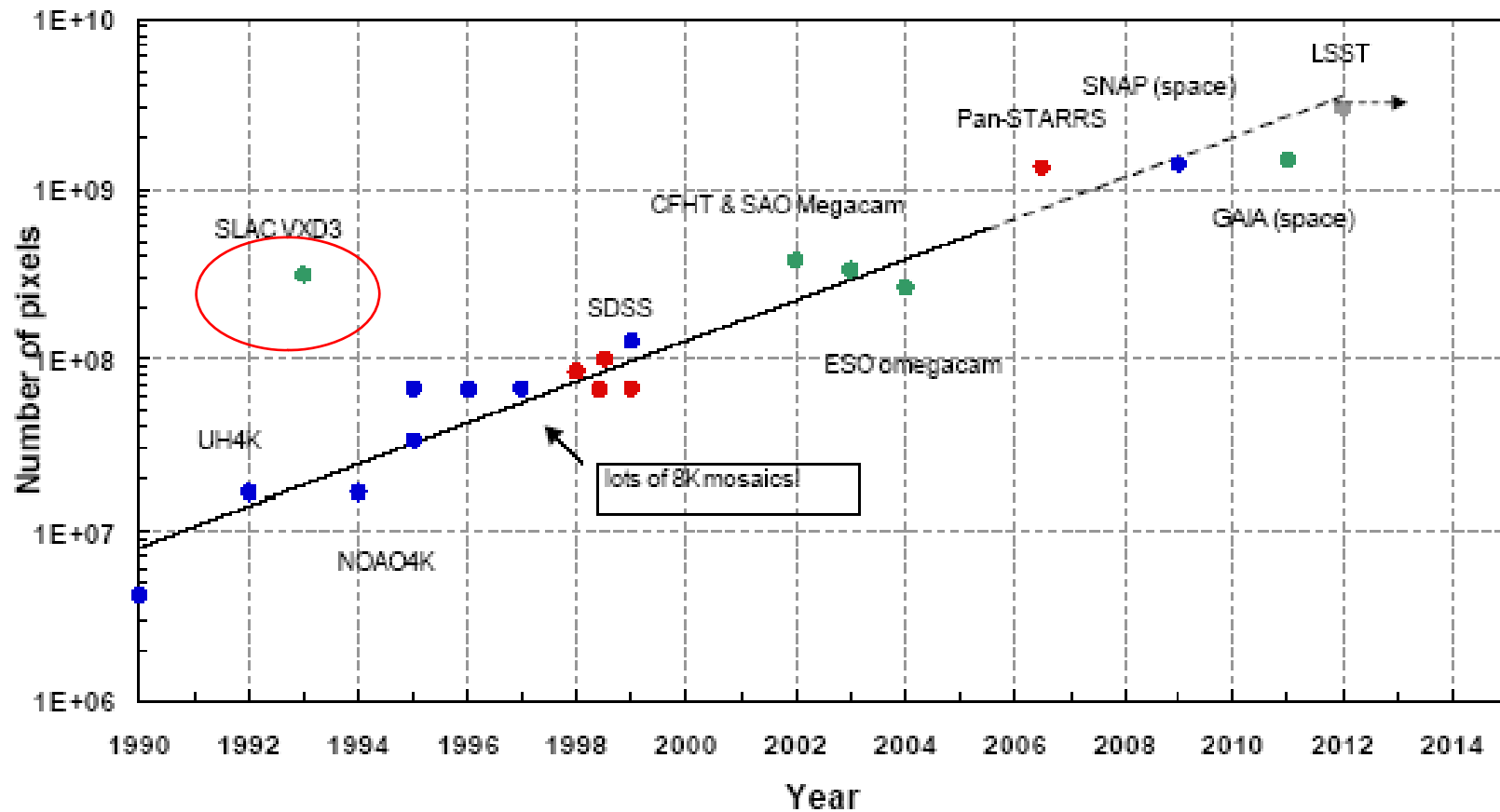
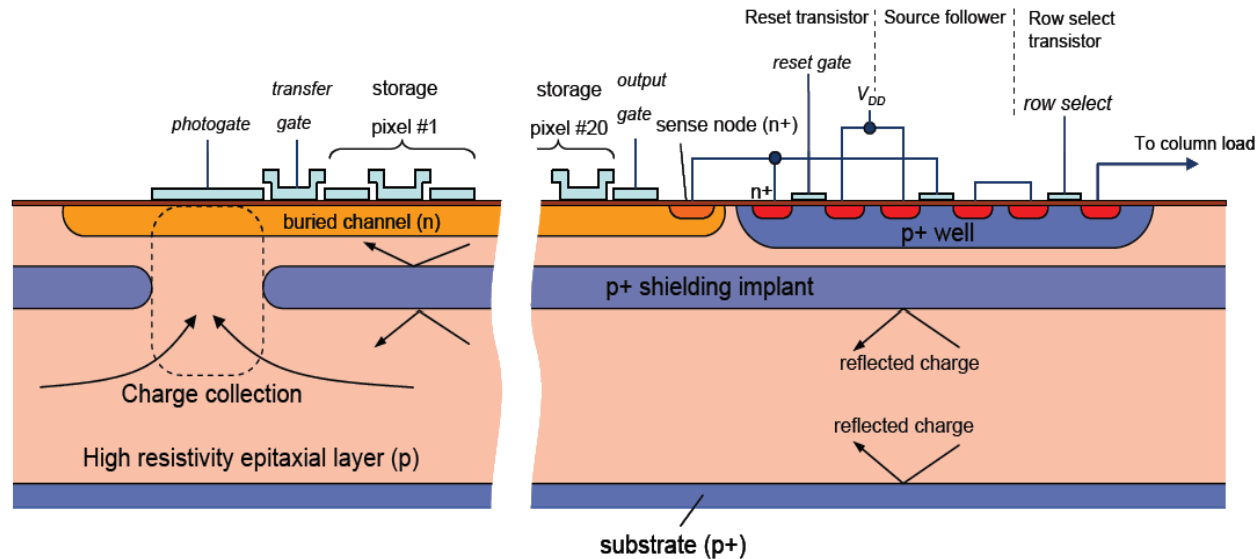

Illustration of focal plane sizes, from Luppino/Burke 'Moore's' law

Focal plane size doubles every 2.5 years

From: Burke, Jordan, Vu, SDW Taormina 2005



Operating principles of the ISIS:

- Charge collected under a photogate
- Charge is transferred to N-cell storage CCD in situ, N times during the 1 ms-long train
- Converted to voltage and read out in the 200 ms-long quiet period after the train
(insensitive to beam-related RF pickup)
- For SPT, 50 μm pixels with binary readout will suffice
- Proof-of-principle ISIS-1 (e2V) demonstrated effective punch-through operation with x-rays; small-pixel version ISIS-2 is now in production with Jazz Semiconductors
- 20 storage cells the goal with 20 μm square pixels for vertexing; 100 cells would easily be accommodated in a 50 μm square pixel

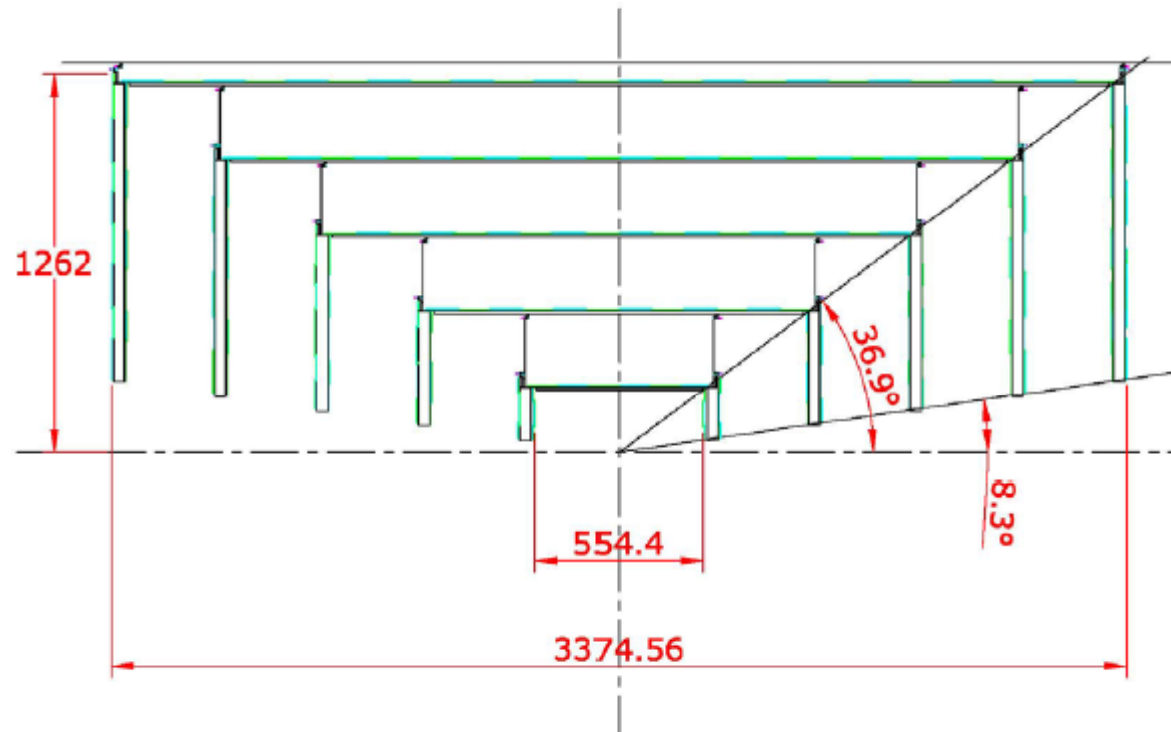

- Barrel and Forward trackers, total area = 70.3 m²
- With 50 μm \times 50 μm pixels – **28.1 Gpix system**
- If each chip is 8 cm \times 8 cm (2.6 Mpix): 11,000 sensors is total