Fixed / Variable Coupler ; Technical Issues

” Comparison of Assembly Procedure “

E. Kako (KEK, Japan)

Outline

- Fixed coupler for STF-Baseline cavities
- Variable coupler (TTF-III) for TESLA
- Coupler assembly procedure at KEK
- Coupler assembly procedure at DESY
- Summary

Fixed Coupler for STF-Baseline Cavities

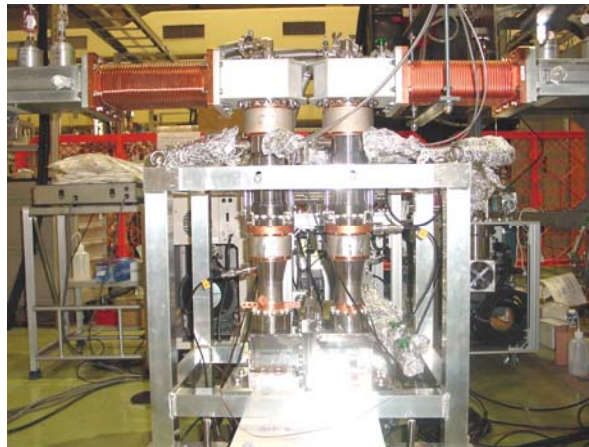
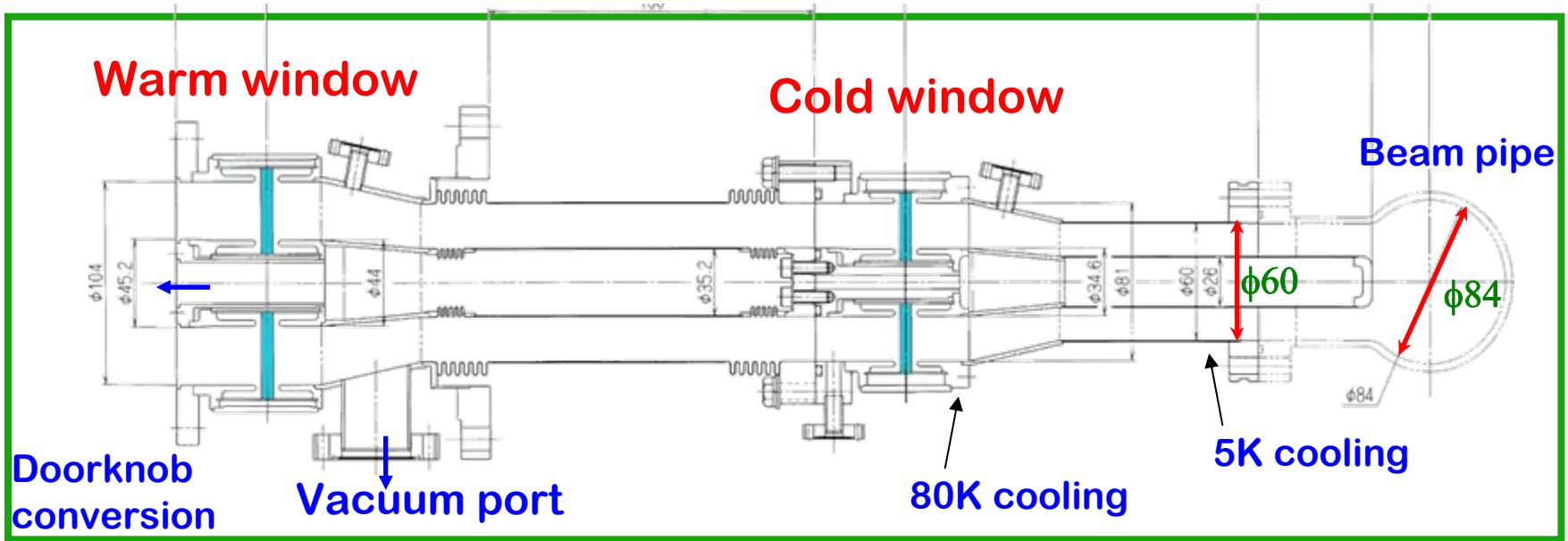

Variable Coupler for TESLA/XFEL Cavities

TTF-III Coupler

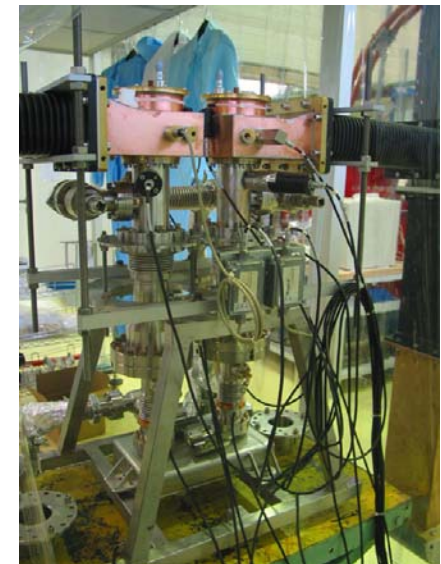
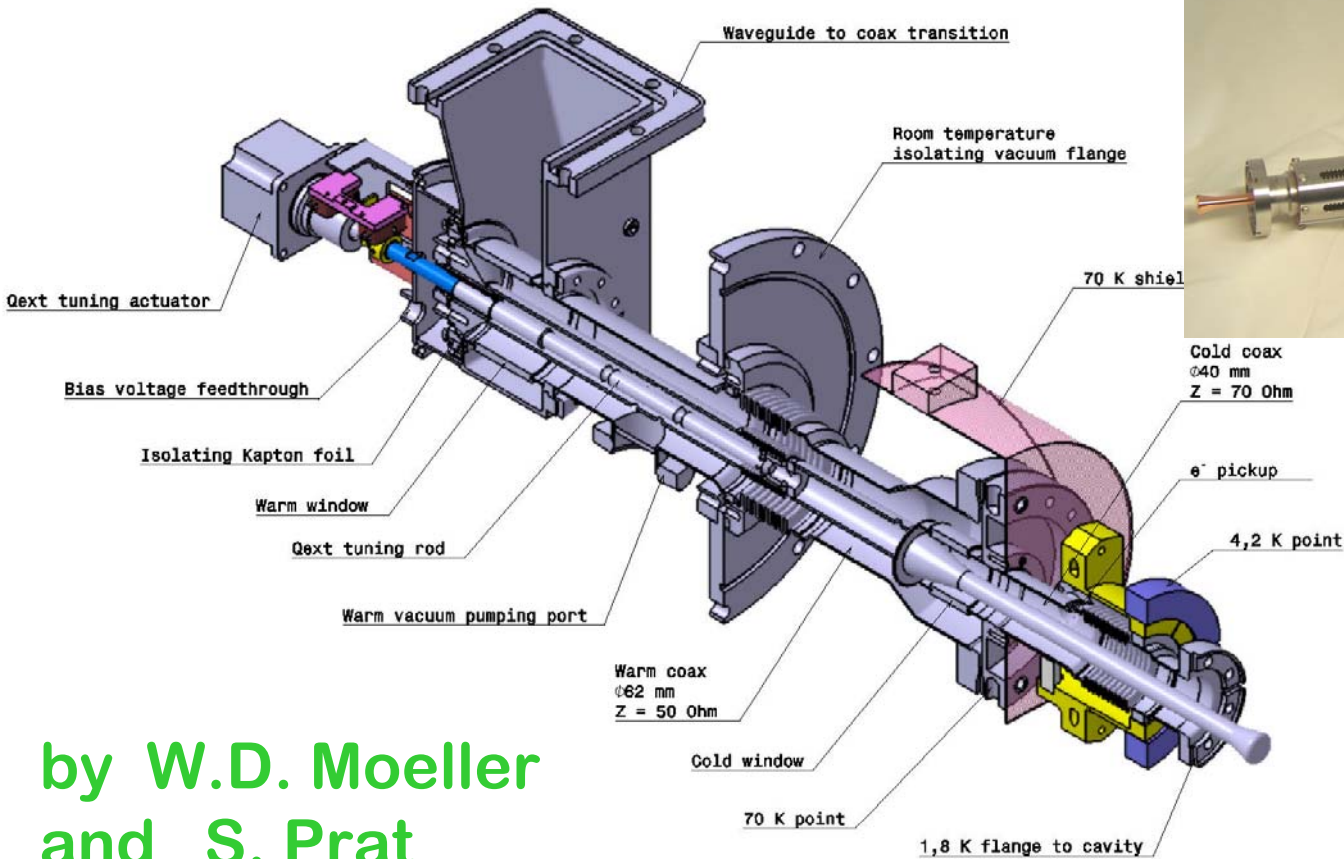

by W.D. Moeller
and S. Prat

Variable Coupler and Fixed Coupler

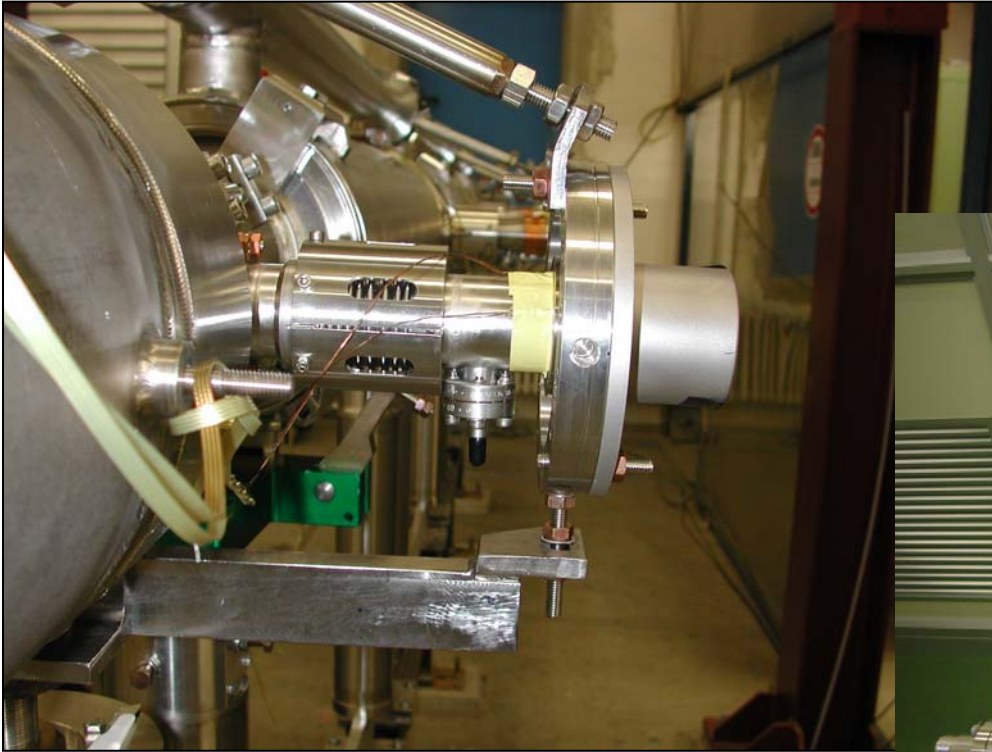

Variable coupler needs a bellow clamp and supporting jigs during cryomodule assembly.

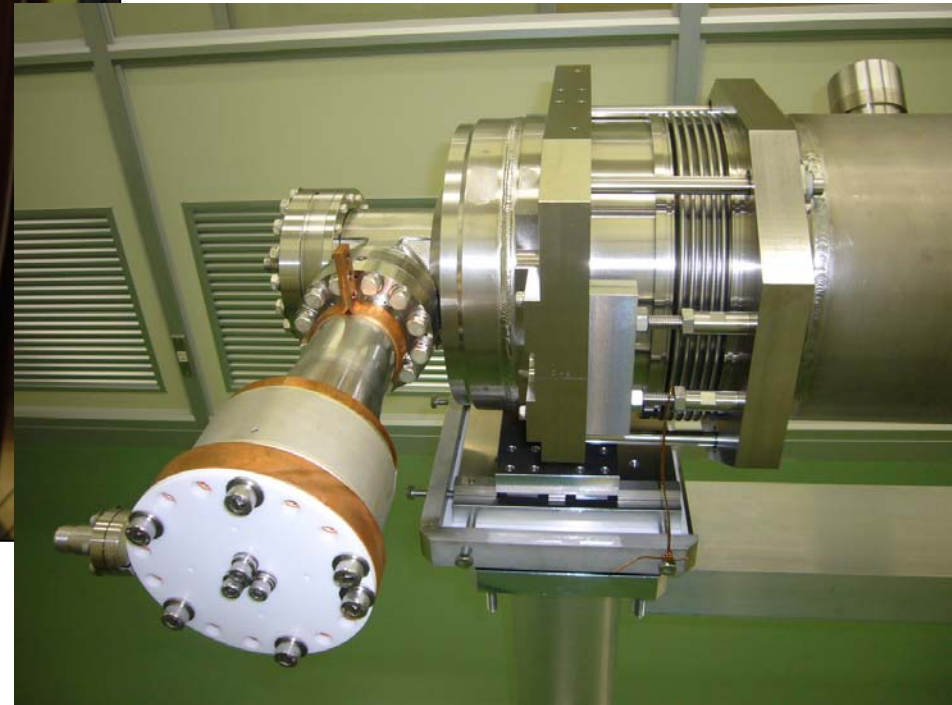

Fixed coupler is so simple that assembling procedure is not complex.

Coupler Assembly Procedure at KEK

1. Disassembly of warm & cold coupler (Clean Room)
in class 1000 clean room.
2. Installation of cold coupler with cavity
in class 10 clean room.
3. Pumping and Leak check in class 1000 clean room.
4. Installation of tuner system and Cavity alignment
outside clean room.
5. Hanging under GRP and Cold mass assembly.
6. Insertion into vacuum vessel. (Cryomodul Assembly Area)
7. Assembly of warm coupler in the tunnel. (STF Tunnel)
8. Attachment of input port flanges.
9. Assembly of doorknob transition.
10. Connection with waveguide system.

Assembly of Fixed Coupler ; (Class 1000)

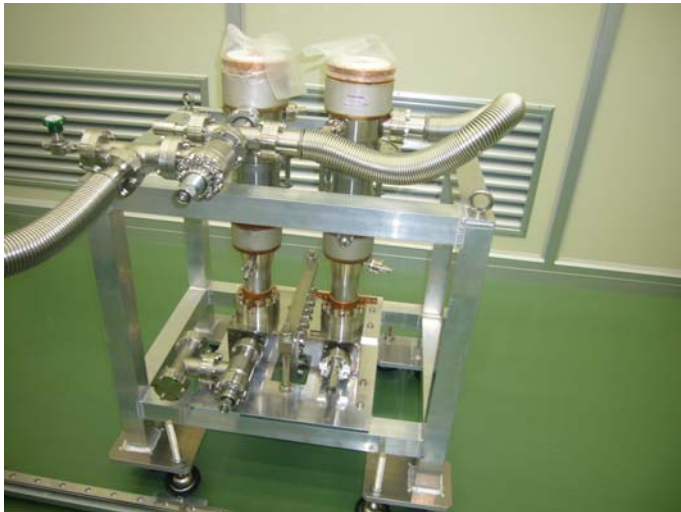

Assembly of Fixed Coupler ; (Class 10)

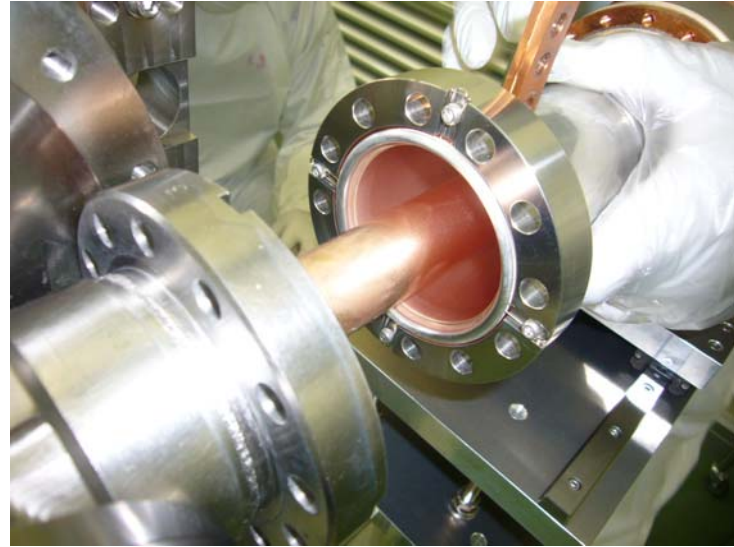

Assembly of Fixed Coupler ; (Class 1000)



From Class 10
To
Class 1000

Pumping

Leak Check

Slow leak
by Ar gas
(40 h to 1 bar)



Assembly of Fixed Coupler ; (outside Clean room)



From
Class 1000
To
Outside
of Clean room

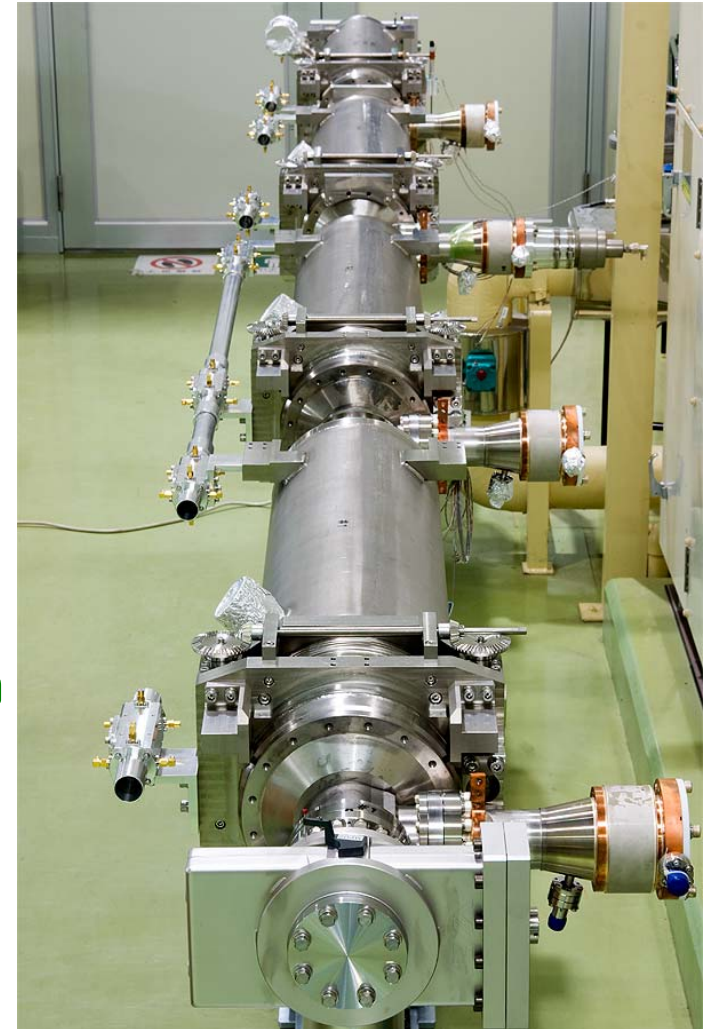

Installation
of Tuner System

Slide Jack Tuner,
Piezo,
Load sensor,
Position monitor

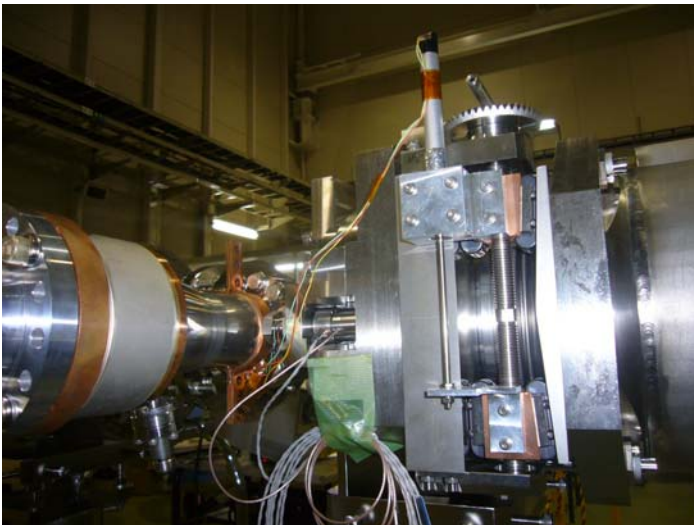

Assembly of Fixed Coupler ; (Cold Mass)



Hanging up
under GRP

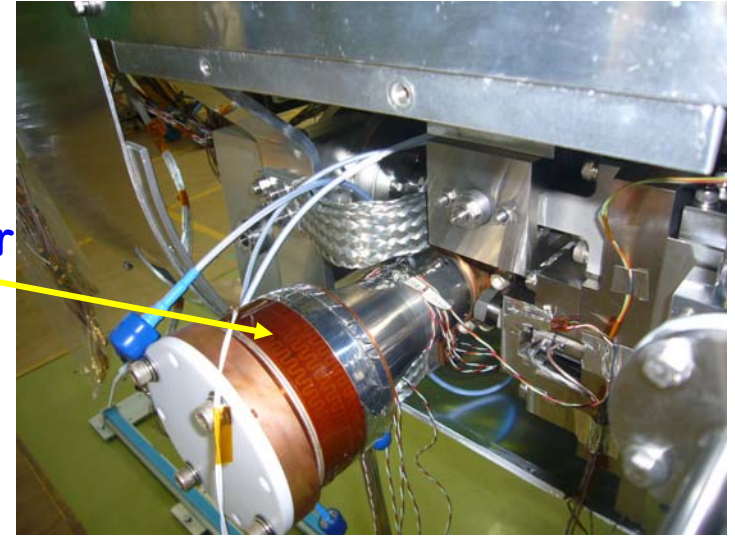

Heater

5 K Shield

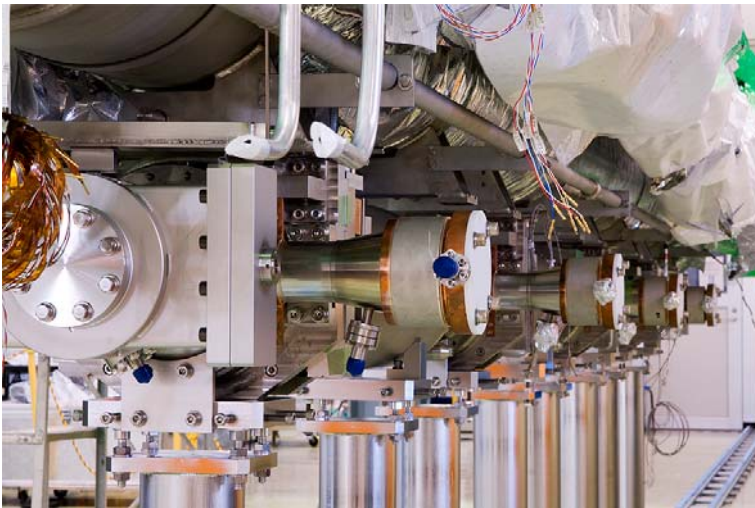

80 K Shield



Assembly of Fixed Coupler ; (into Vacuum vessel)



Assembly of Fixed Coupler ; (Warm coupler)

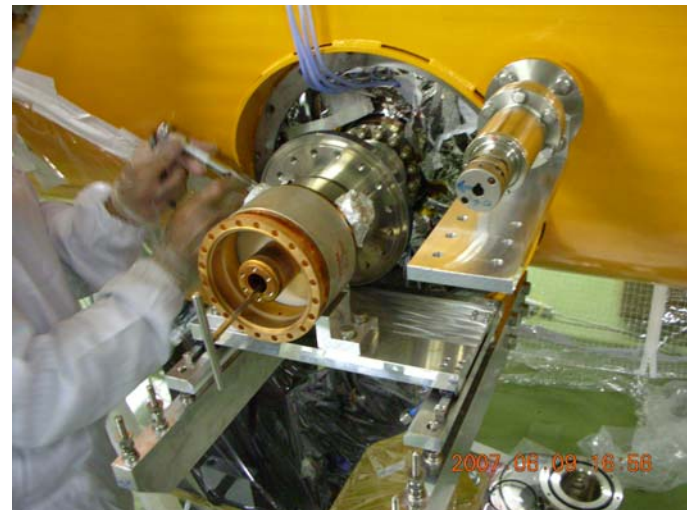
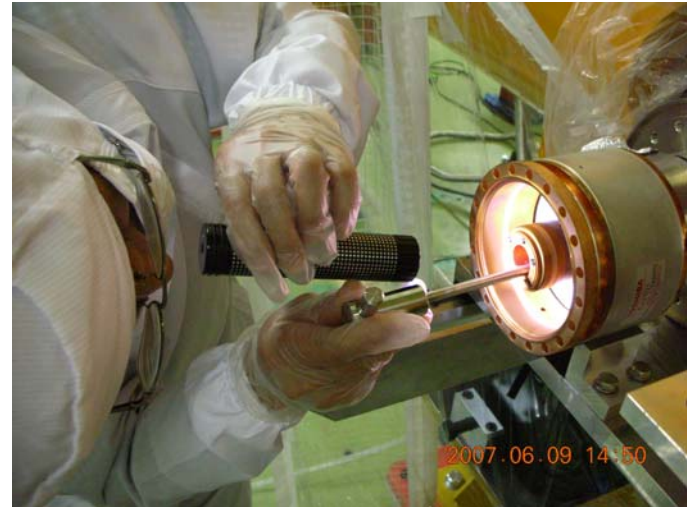

Assembly of Fixed Coupler ; (Input Flange)

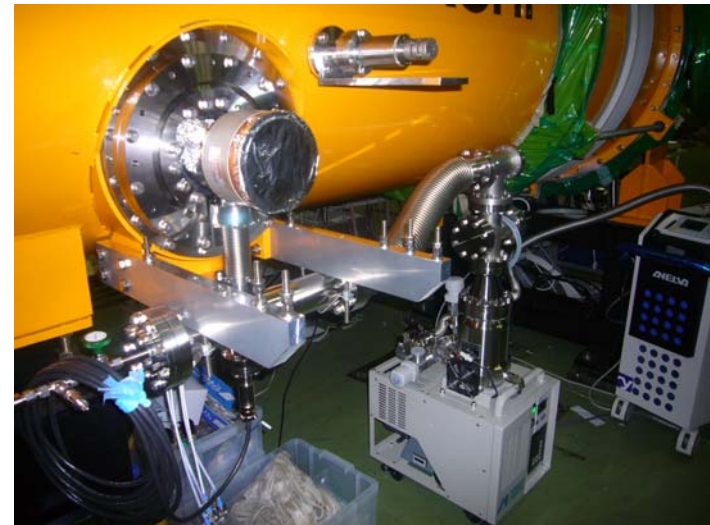
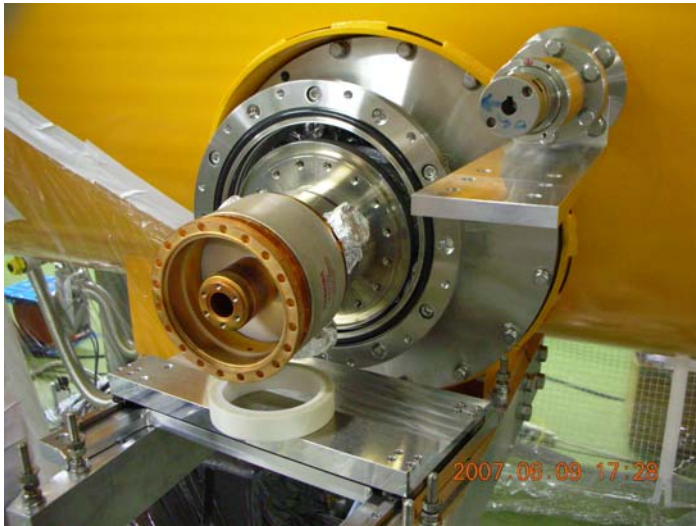

Assembly of Fixed Coupler ; (Doorknob)

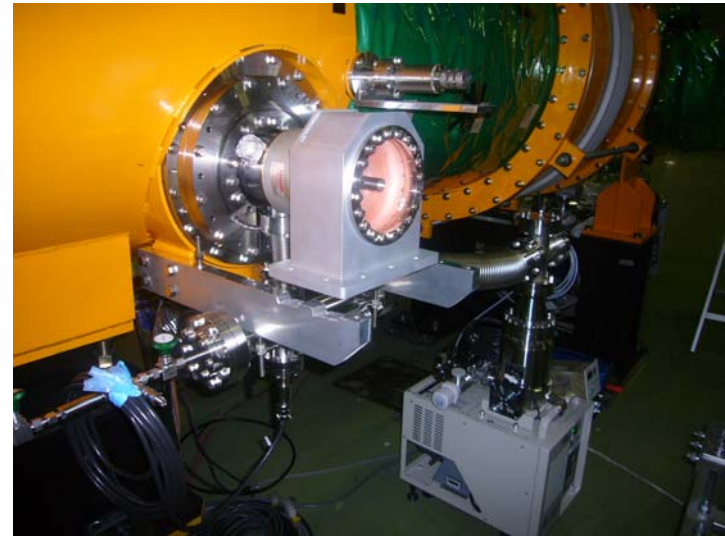
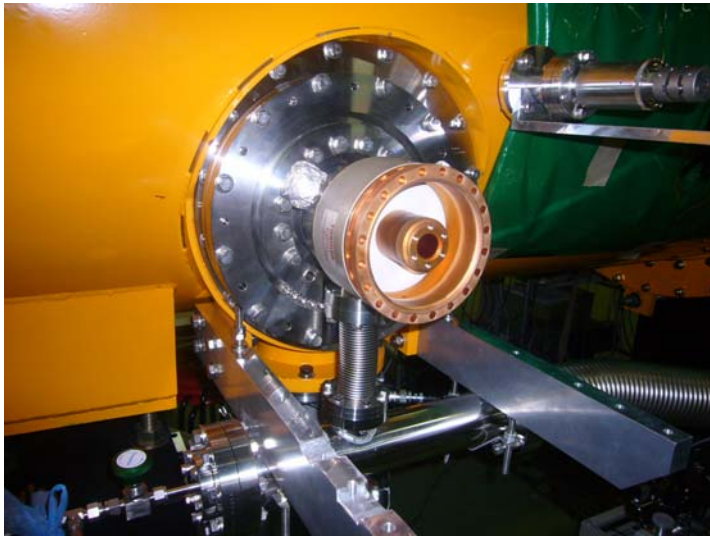
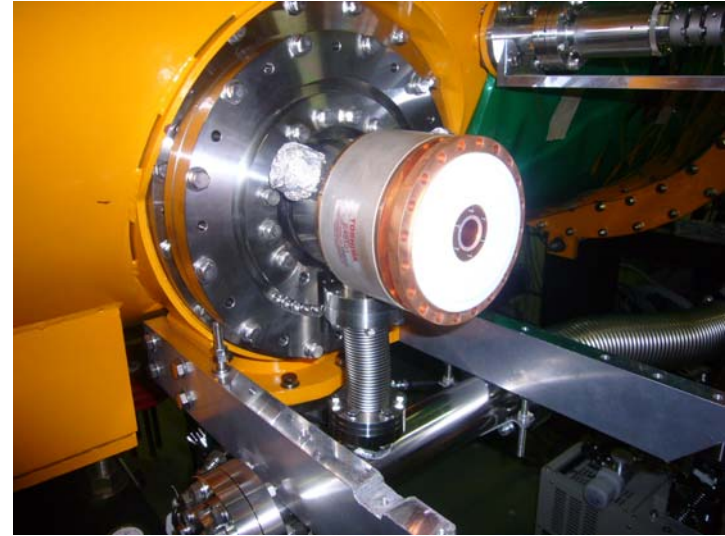
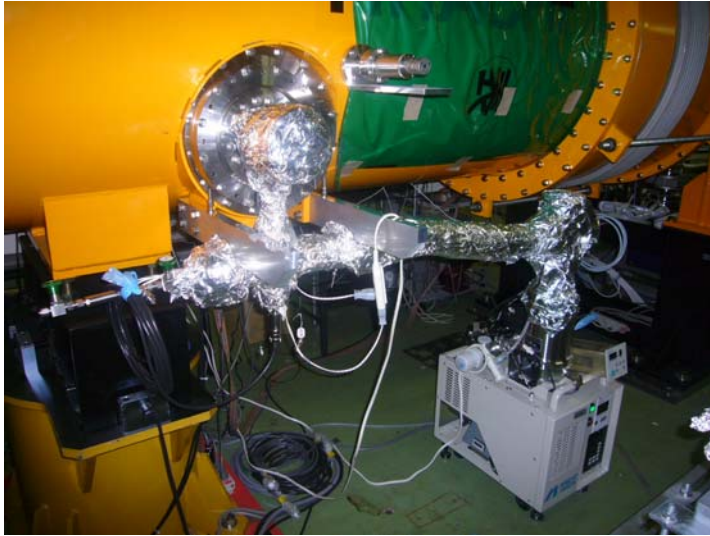

Assembly of Fixed Coupler ; (WG system)

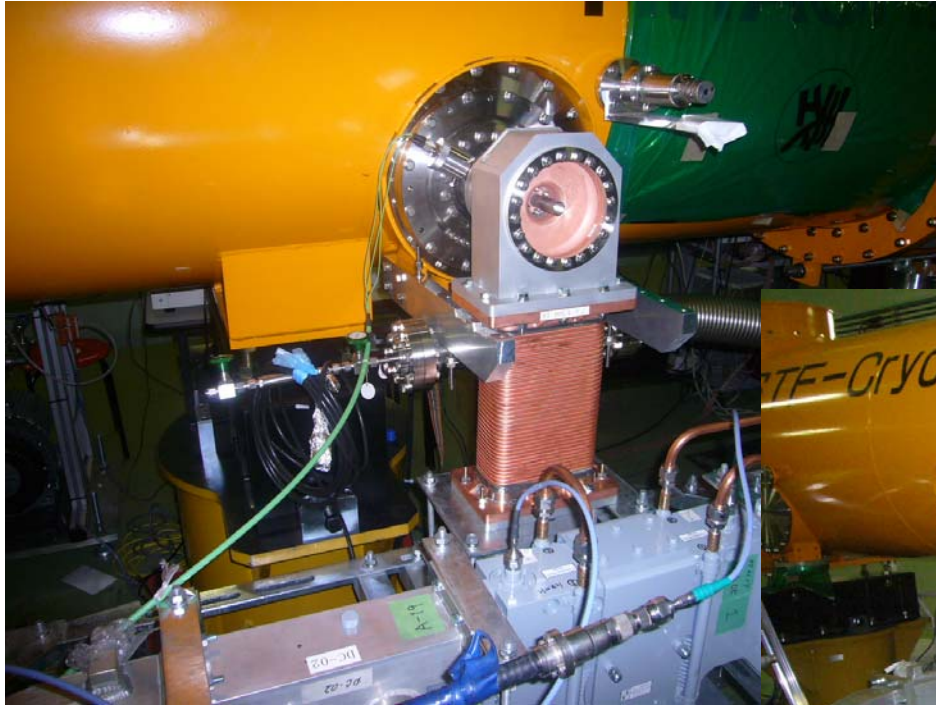

Coupler Assembly Procedure at DESY (1)



Cavity String outside the Clean Room

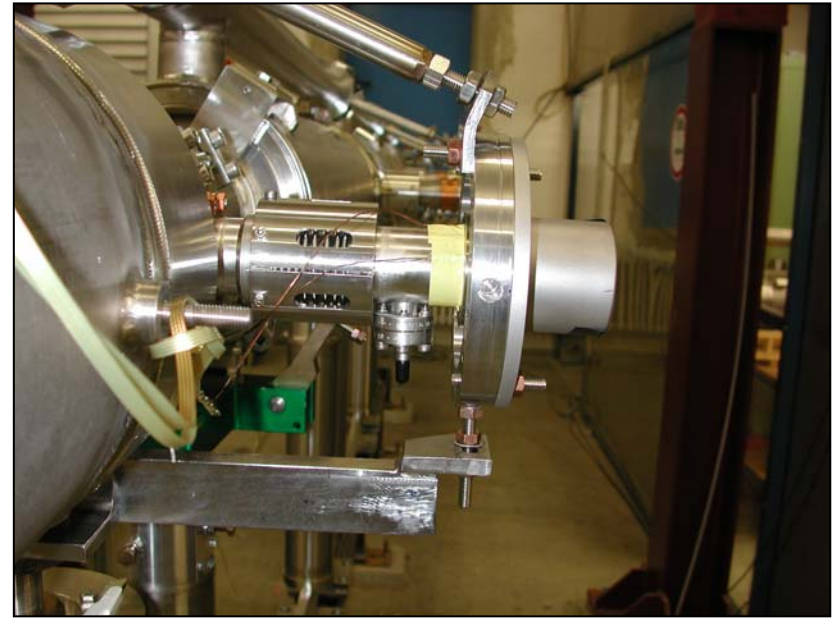

- Coupler is supported by the bellow clamp and from the bottom
- Cavity is NOT under vacuum
- Disassembly of bellow clamp
- Assemble 70 K and 4 K coupler shields
- Connecting the shields with threaded rods
- Connect cavity string to cold mass
- Assemble support on 70 K shield

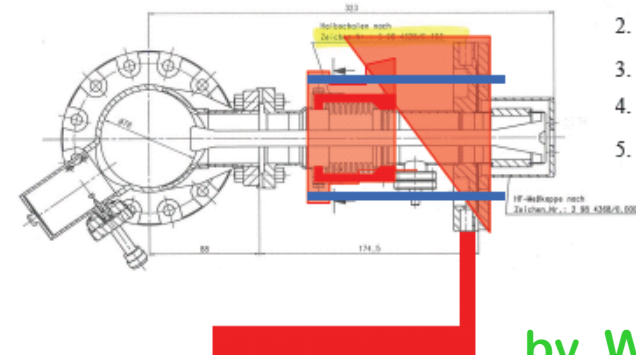

1. Remove bellow clamp
2. Add 4K shield
3. Add 70 K shield
4. Add threaded rods
5. Remove bottom support

by W.D. Moeller
(DESY)



Wolf-Dietrich Möller, DESY

12.1.2005



Wolf-Dietrich Möller, DESY

12.1.2005

Coupler Assembly Procedure at DESY (2)

String Assembly to Cold Mass, 2

Both shields are thermally connected by braids

4 K shield is closed.

Cold part is supported temporarily at the 70K shield

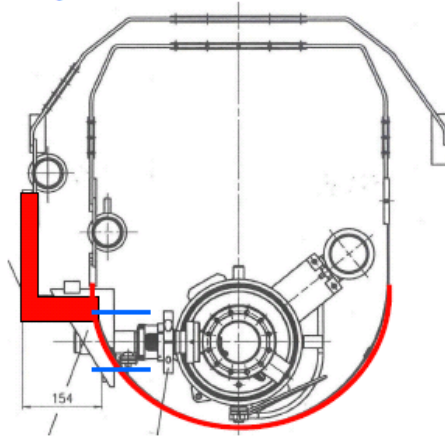

Wolf-Dietrich Möller, DESY

12.1.2005

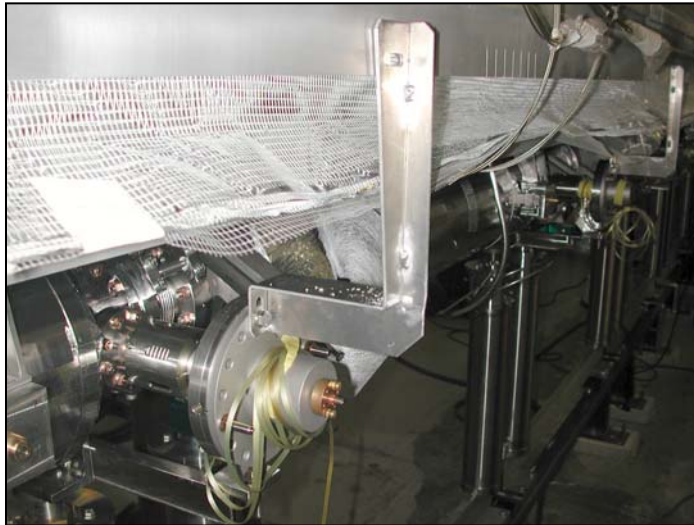

70 K shield closed

Cold part supported **only** by threaded rods between the 70 K and 4 K shields

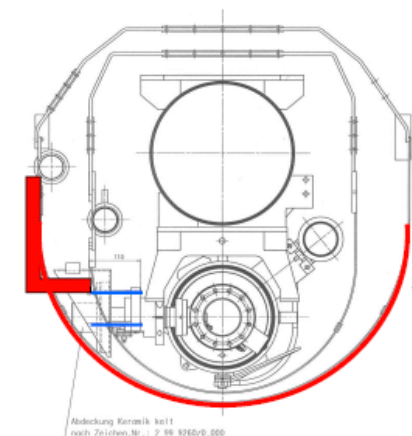

Abdeckung Keramik heißt
nach Zeichen-Nr.: Z. 98. 9260/0. 000



Wolf-Dietrich Möller, DESY

12.1.2005



Coupler Assembly Procedure at DESY (3)

70 K shield closed, 2

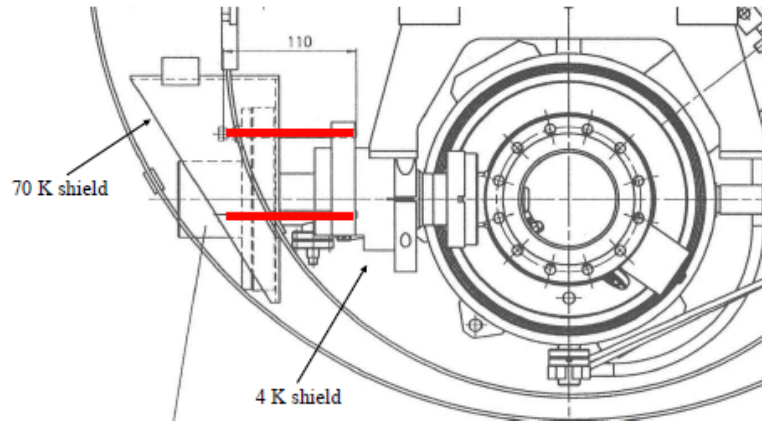

Wolf-Dietrich Möller, DESY

12.1.2005

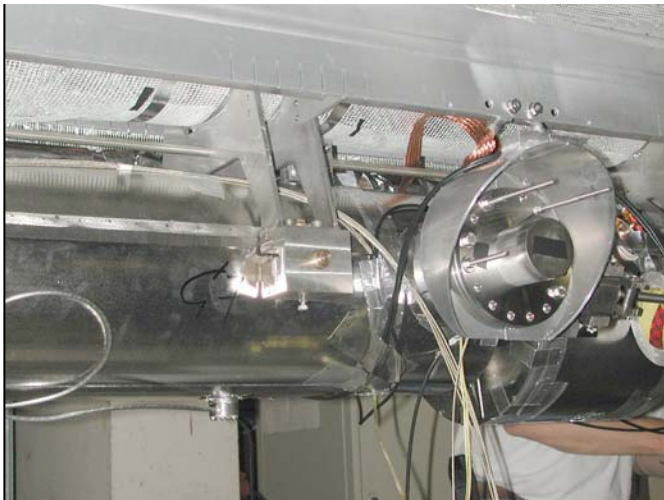

Cold Mass into the Vacuum Vessel

- Add super insulating foil
- Move cold mass into the vacuum vessel
- Connect the three fix points
- Cut super insulating foil
- Start warm coupler assembly

by W.D. Moeller
(DESY)



Wolf-Dietrich Möller, DESY

12.1.2005

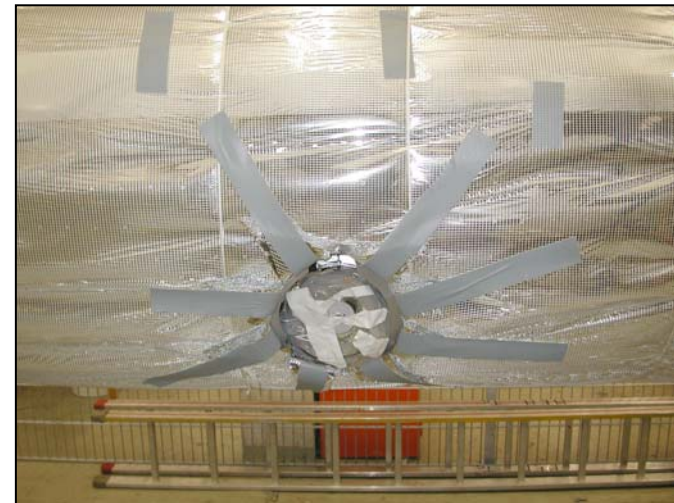

Coupler Assembly Procedure at DESY (4)

Warm part assembly

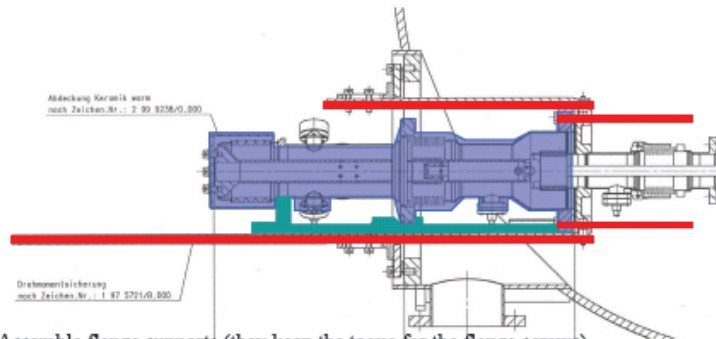

1. Assemble flange supports (they keep the torque for the flange screws)
2. Take the threaded rods out
3. Introduce the warm part
4. Tighten the bolts



Wolf-Dietrich Möller, DESY

12.1.2005

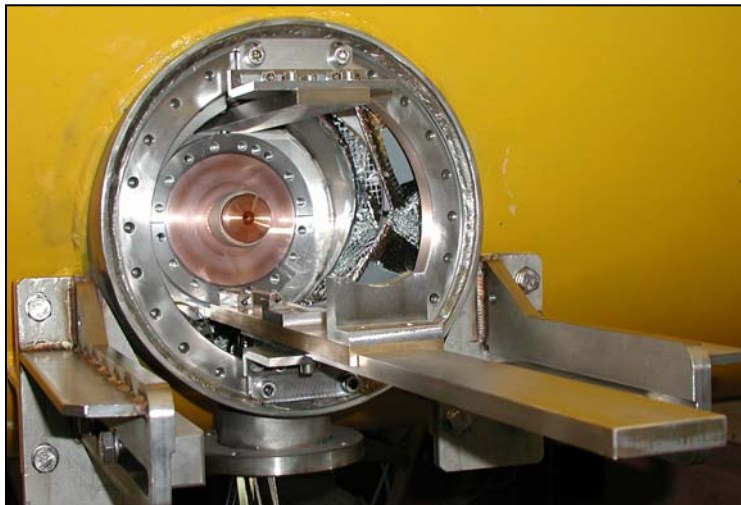

Close the isolation vacuum

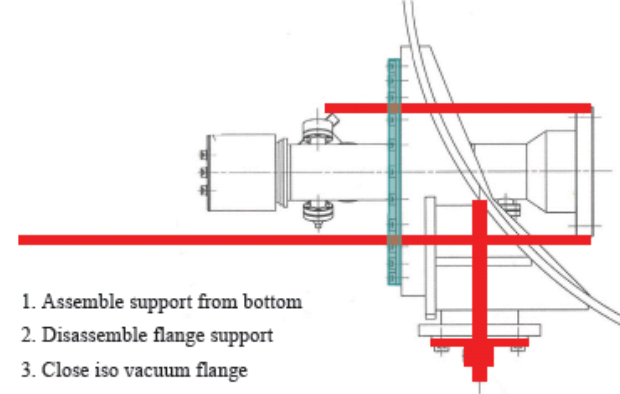

1. Assemble support from bottom
2. Disassemble flange support
3. Close iso vacuum flange
4. Disassemble support from bottom
4. Pump & leak check

by W.D. Moeller
(DESY)



Wolf-Dietrich Möller, DESY

12.1.2005

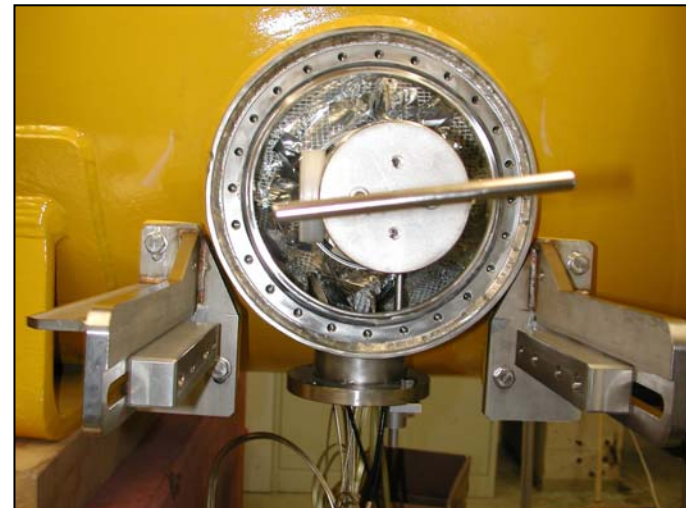

Coupler Assembly Procedure at DESY (5)

Pumping system

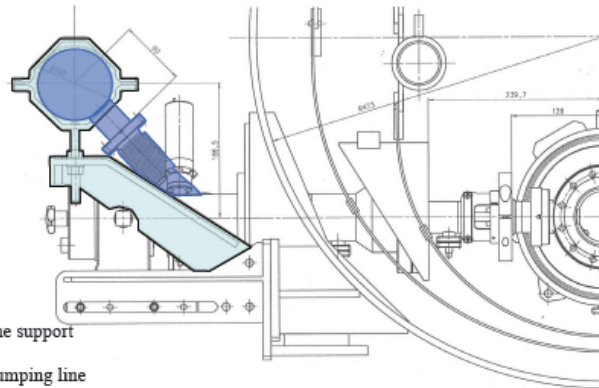

Wolf-Dietrich Möller, DESY

12.1.2005



Wolf-Dietrich Möller, DESY

12.1.2005

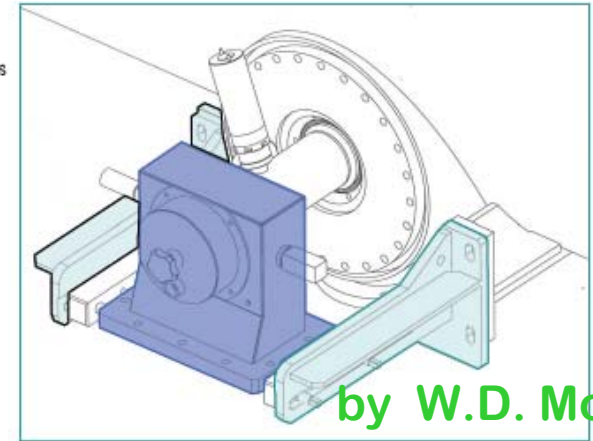

by W.D. Moeller
(DESY)

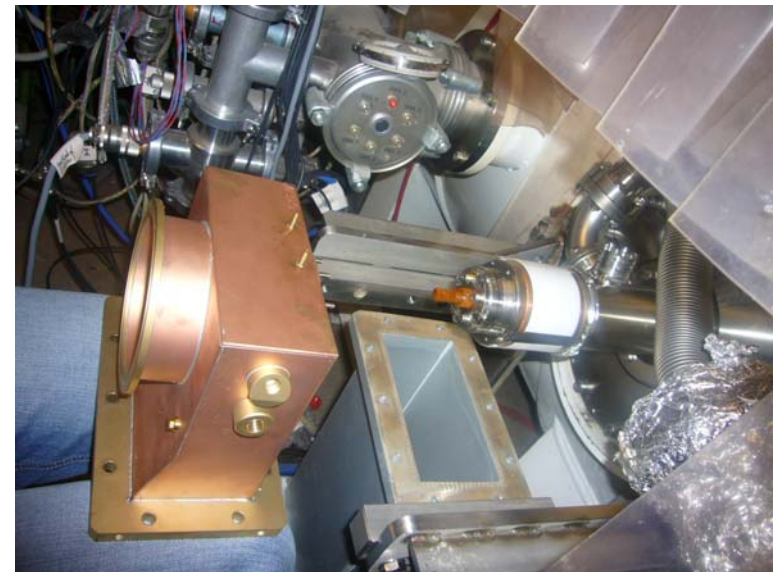

Coupler Assembly Procedure at DESY (6)

Bellow Support, Cavity under Vacuum

Concluding Remarks

- Coupler assembly & alignment in clean room class 10 was not described here (Axel Matheisen)
- Assembly under cavity vacuum:
 - Bellow clamp could stay and rest on 4 K shield (we have to look in the details)
- Duration: 1 coupler / 2 h plus pumping and leak check

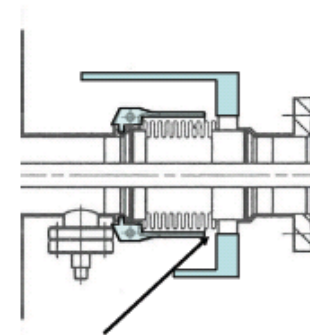

The bellow clamp can rest on the 4 K shield

by W.D. Moeller
(DESY)

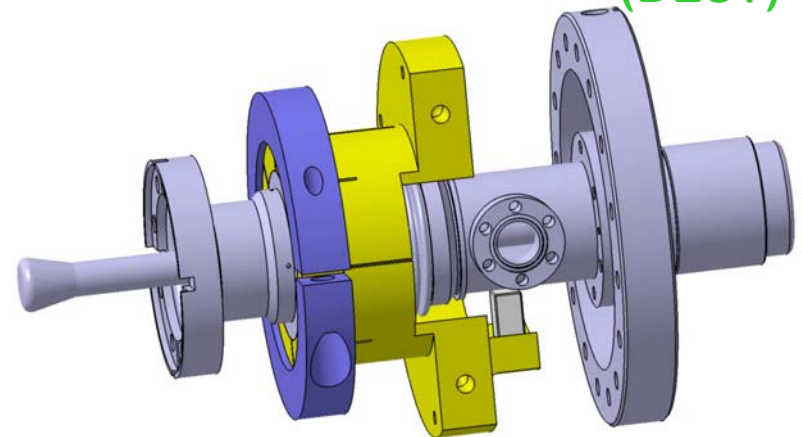

Sliding Support



Wolf-Dietrich Möller, DESY

12.1.2005

SUMMARY

- Fixed coupler does not require supporting jigs during assembly.
- Assembly procedure of fixed coupler is so simple and very easy.

END

Thank You for Attention !
