

Layout and simulation of the ATF2
feedback/feed-forward system
in the context of FONT

Javier Resta Lopez
(JAI, Oxford University)
for the FONT project group

ATF2 Software Review workshop
LAL, Orsay, 18-20th June 2008

Introduction

ATF2: Final focus test beam line facility at KEK

In principle the ATF2 optics design is identical to that for the ILC in spite of the two order of magnitude lower beam energy (Raimondi & Seryi final focus system).

Perfect bed to make experiments on beam dynamics and technologies for beam delivery systems in linear colliders.

The two major goals for the ATF2 facility:

- achievement of a 30-40 beam sizes
- control of beam position down to 5 % of the rms beam size at the IP, which will require a stability control better than 1 μ m at the ATF2 final focus entrance.

M. Woodley optics v3.8

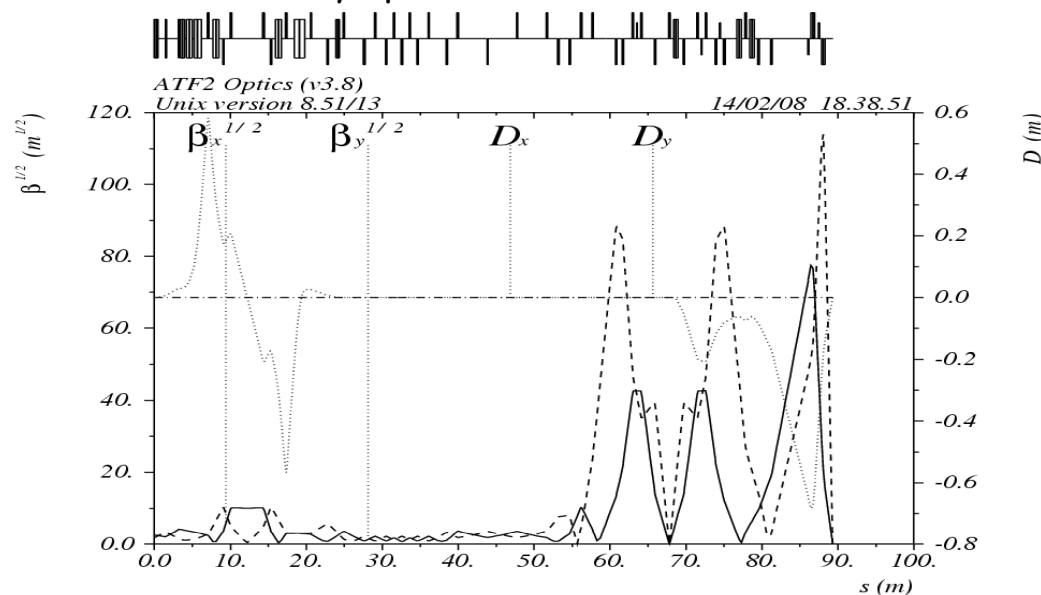

Javier Resta Lopez

18th June 2008

Parameter	ATF2	ILC (nominal)
Nominal energy [GeV]	1.3	250
Energy spread [%]	~ 0.1	~ 0.1
$\gamma\epsilon_y^*$ [nm·rad]	30	40
$\gamma\epsilon_x^*$ [nm·rad]	3000	10000
β_y^* [mm]	0.1	0.4
β_x^* [mm]	4.0	21
Bunch length σ_z [mm]	8.0	0.3
Single bunch operation:		
	Goal A	Goal B
N_{bunch} [10^{10}]	0.5	0.5
Multibunch operation:		
	Goal A	Goal B
n_{bunch}	1-20	3-20
N_{bunch} [10^{10}]	0.5	0.5

Introduction

- The ATF2 beam line will allow us to test fast intra-train feed-back (FB) and feedforward (FF) systems for beam stability:
 - FB system in extraction line (to operate in multibunch mode)
 - FF ring to extraction line (which can operate in multibunch or single bunch mode) :
 - to model the ILC Turnaround trajectory FF system [A. Kalinin, P. N. Burrows, "Turnaround feed-forward correction at the ILC", EUROTeV-REPORT-2007-050, June 2007]
 - to stabilise the beam in the ATF2 correcting the jitter originated in the DR
- **FONT**: Feedback systems on Nanosecond Timescales.

Summary of the results of latency time of the previous FONT tests

Test	Facility	Train length [ns]	Bunch spacing [ns]	Latency [ns]
FONT1	NLCTA (SLAC)	170	0.087	67
FONT2	NLCTA (SLAC)	170	0.087	54
FONT3	ATF (KEK)	56	2.8	23
FONT4	ATF (KEK)	420	140	132

FONT5 is being designed to perform both FB and FF tests at ATF2!

Layout of FONT at ATF2

Goal: adaptation of upstream FONT system for ATF2

- FF+ FB systems in the ATF2 extraction line (EXT):
 - A pair of kickers (K1 & K2) for the correction of (y, y')
 - The kickers are common for FF and FB
 - Each kicker has an adjacent pickup (P1 & P2) that is used for response matrix construction
 - Downstream witness pickup P3 (also available for FB system test)
 - Pickups (BPMs) in the ATF2 EXT are adjacent to quadrupoles

Location constraints:

- Relatively high beta y (higher resolution tolerances)
- $\pi/2$ phase advance kicker-BPM
- Low time flight to reduce latency (the total latency goal ~ 150 ns)

Position taken at the center of the element

Element	s [m]
KICKER	
K1 (for y correction)	26.94
K2 (for y' correction)	29.84
BPM	
P1	27.23
P2	30.13
P3	33.00

kicker length = 30 cm

BPM length = 12 cm

Layout of FONT at ATF2

M. Woodley's lattice v3.8

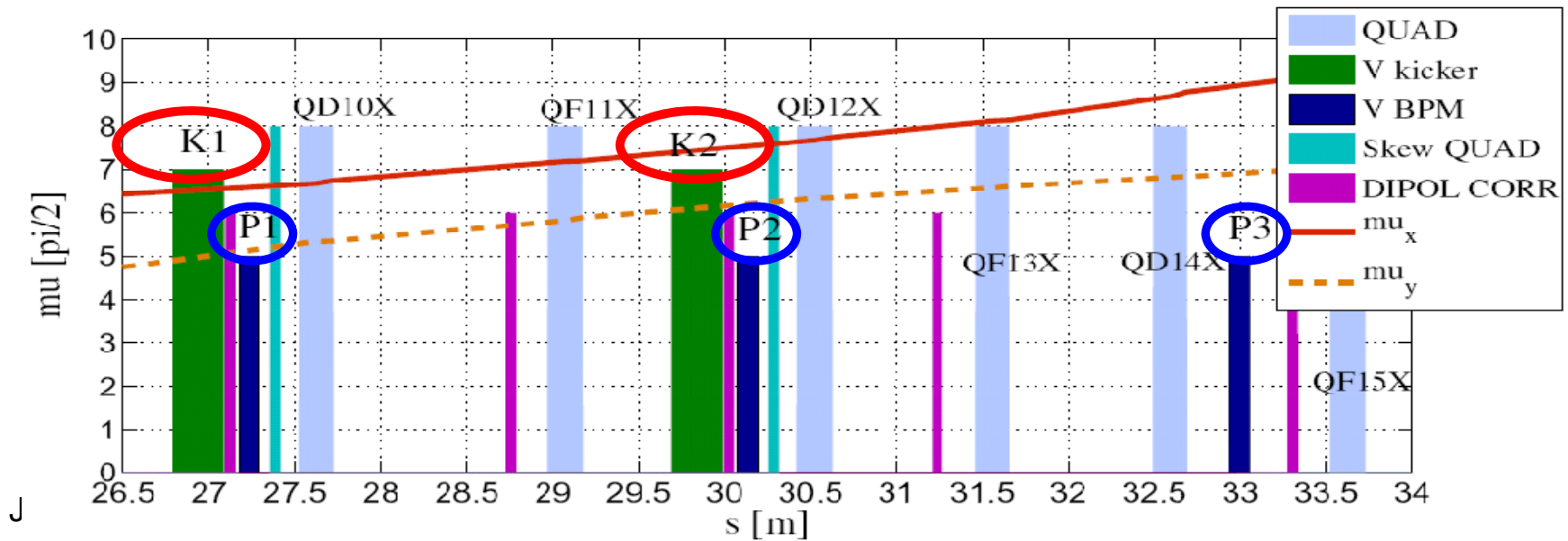
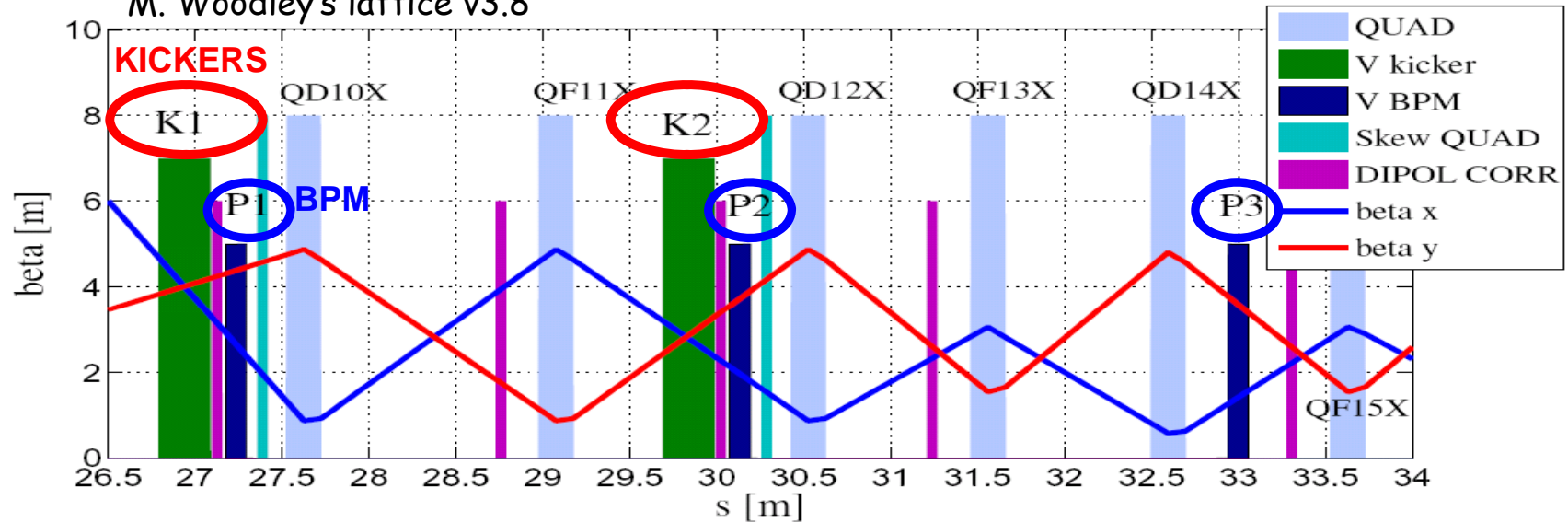

Tentative kicker parameters

(approximate estimate)

Kick angle of fast stripline kicker:

$$\Delta\theta = 2g \frac{eV}{E} \frac{L}{a}$$

“g” is the stripline coverage factor or geometry factor:

$$g = \tanh\left(\frac{\pi\omega}{2d}\right) \leq 1 \quad (\text{determined by the shape of the electrode})$$

V: peak voltage

E: beam energy (1.3 GeV)

R: impedance (50 Ω)

L: kicker length (30 cm without flanges)

a=2*r*: kicker gap width (~15 mm)

r: half gap

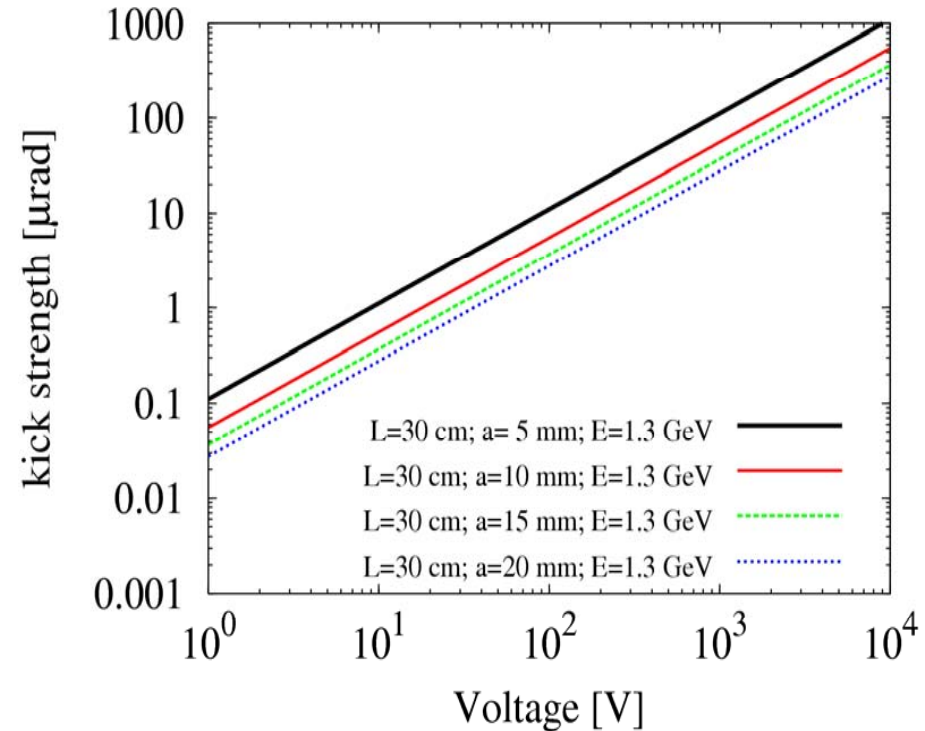

Rise and fall times of the pulse : < 150 ns (avoiding crosstalk between subsequent bunches)

Constraint: *a* < 20 mm (beam line aperture)

For example: *a*=15 mm; kick of 10 μrad ⚡ ⌚ 0.4 kV

a=15 mm; kick of 100 μrad ⚡ ⌚ 3.0 kV

Simulation set up for orbit correction

- Using the tracking code Placet-octave (developed at CERN)
- Only considered the y, y' correction
- Added a total of 50 BPM along the ATF2 line in order to study the jitter propagation and the correction effect from the correction region to the IP
- Two kickers (K1 & K2) for vertical position (Y) and angle (θ) correction
- Two pickups (P1 & P2) for transfer matrix reconstruction
- Normal random distribution of 100 initial vertical jitter positions with a width of $\pm 40\% \sigma_y$ (rms beam size at the entrance of the extraction line)
- Assuming a BPM rms noise of $1 \mu\text{m}$ (input BPM resolution)
- Assuming a kicker strength error of $< 0.5\%$
- Introducing ground motion (GM) misalignment (model K)

Simulation set up

Impact of the GM in the vertical element position

For the simulation we have used a GM package which is implemented in the tracking code Placet and is based on the models provided by A. Seryi

[A. Seryi, <http://www.slac.stanford.edu/~seryi/gm/model>]

Vertical misalignment of the elements in the ATF2 beam line applying the GM **model K** (KEK site) at different time moments:

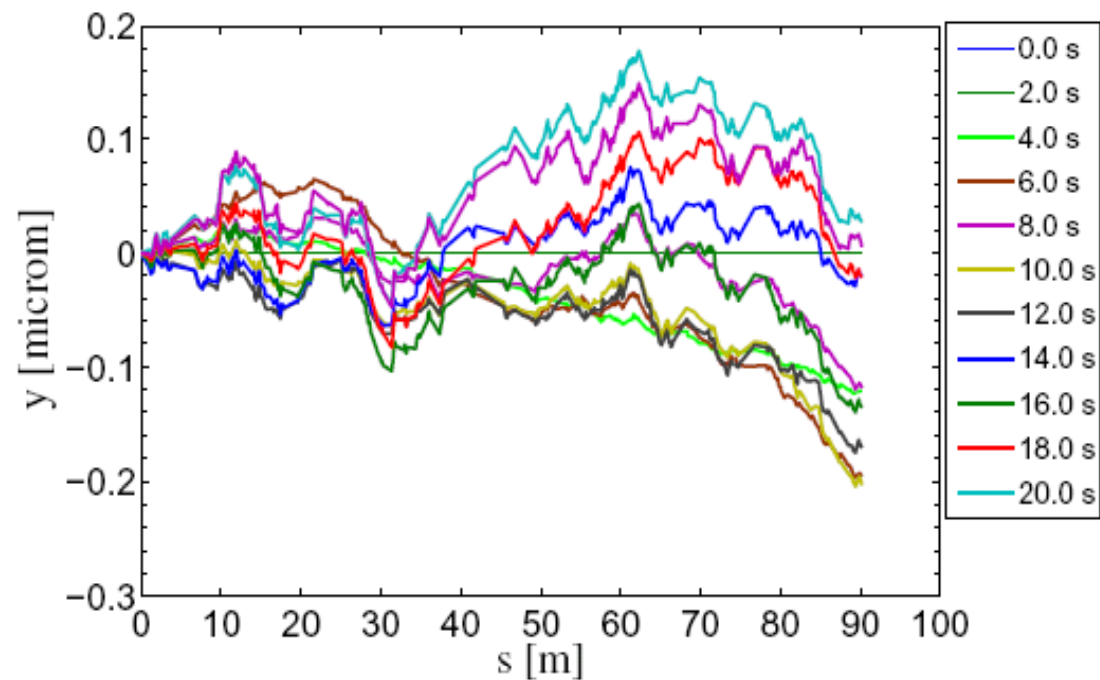

Estimate of the BPM resolution

- Three BPM method:

In a dispersion-free section, the beam offset y_3 at an arbitrary line position s_3 can be predicted from the offsets y_1 and y_2 at two other positions s_1 and s_2 respectively

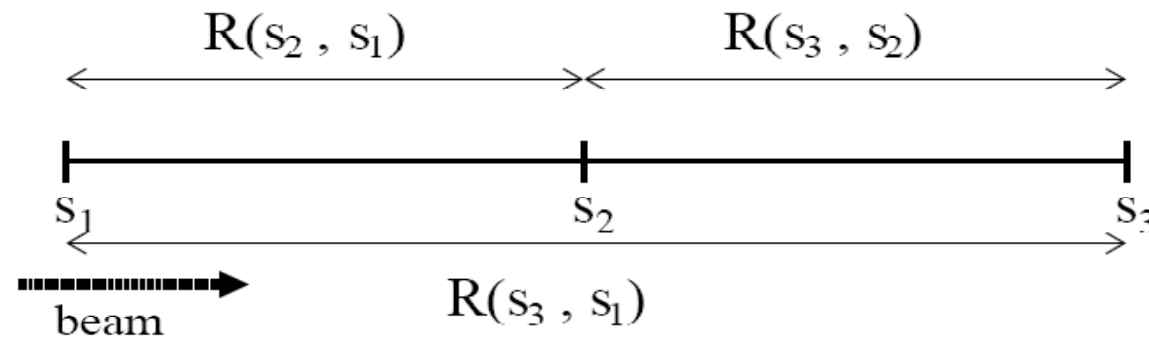

$$y_3 = \left(R_{33}(s_3, s_1) - \frac{R_{34}(s_3, s_1)R_{33}(s_2, s_1)}{R_{34}(s_2, s_1)} \right) y_1 + \frac{R_{34}(s_3, s_1)}{R_{34}(s_2, s_1)} y_2$$

The transfer matrix elements can be measured using the three BPMs

Transfer matrix reconstruction

- The transfer matrix between two positions in a line can be constructed using two BPMs. Considering only linear optics:

$$\begin{pmatrix} y \\ y' \end{pmatrix}_2 = \begin{pmatrix} R_{33} & R_{34} \\ R_{43} & R_{44} \end{pmatrix} \begin{pmatrix} y \\ y' \end{pmatrix}_1$$

- Let the point 1 (BPM P1) be adjacent to a corrector or kicker (K1)

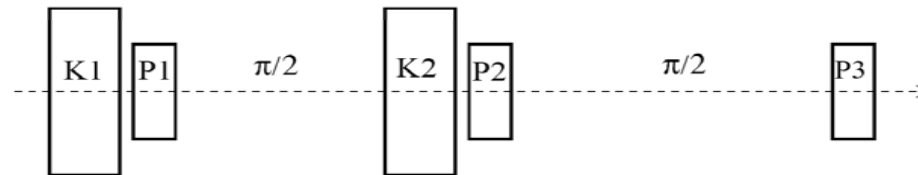

- Then two measurements are required to determine R_{34} :
 - with $y_2(\text{measure1})$ at P2 obtained with the nominal trajectory and $(y, y')_1$ at P1
 - with $y_2(\text{measure2})$ at P2 obtained with the nominal trajectory and $(y, y' + \Delta\theta)_1$ at P1, where $\Delta\theta_1$ is an arbitrary kick angle introduced by the corrector K1
- Then $R_{34} = \{y_2(\text{measure 2}) - y_2(\text{measure 1})\} / \Delta\theta_1$

BPM resolution for FONT at ATF2

- From simulation results using the tracking code Placet-octave for 100 shots

It is obtained for BPMs with input noise of 1 μm and shows the method accuracy for the given statistics

$$\sigma_{\text{reso},i} = \sqrt{\langle (y_{i,\text{measured}} - y_{i,\text{predicted}})^2 \rangle}$$

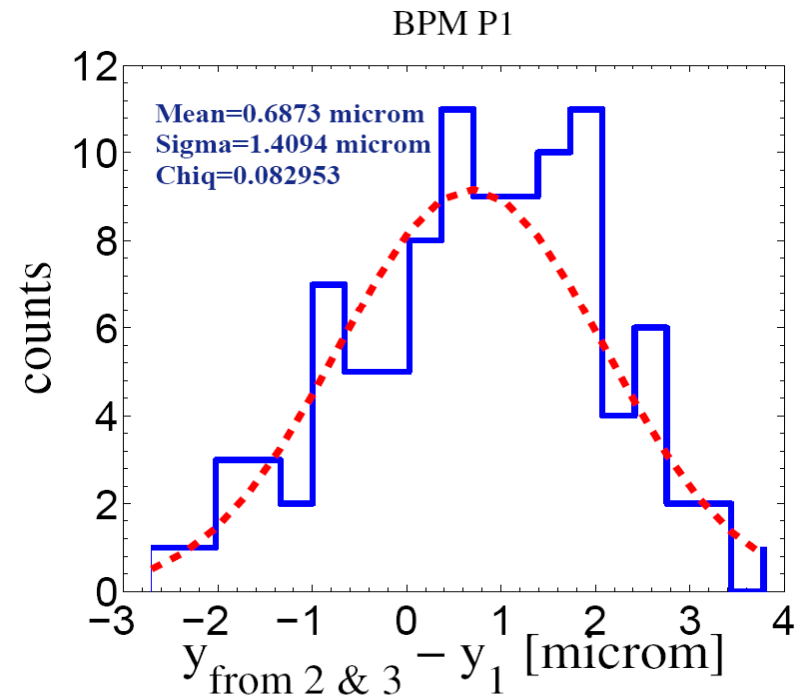
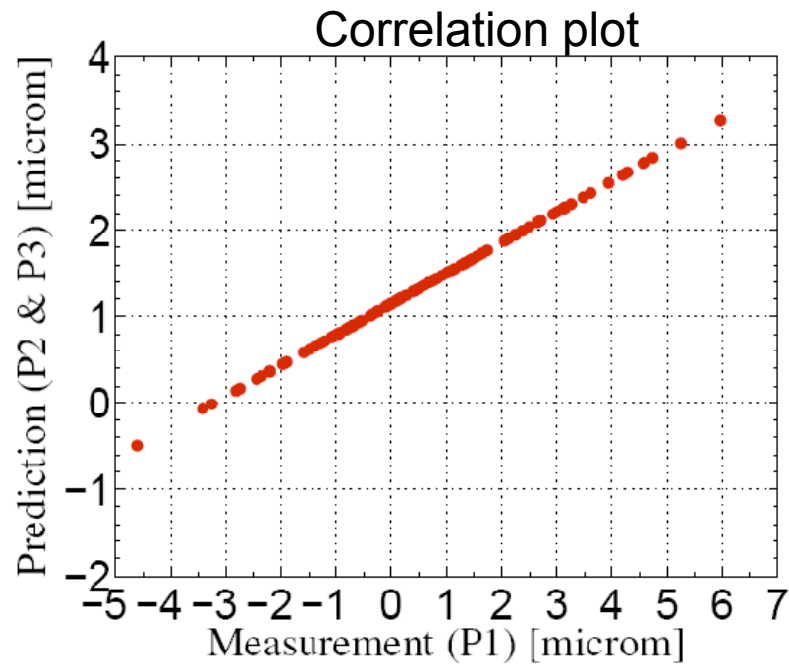

BPM resolution for FONT at ATF2

- From simulation results using the tracking code Placet-octave

BPM P_i	Resolution $\sigma_{\text{rcso},i}$
P1	1.4094 μm
P2	2.4002 μm
P3	1.5542 μm

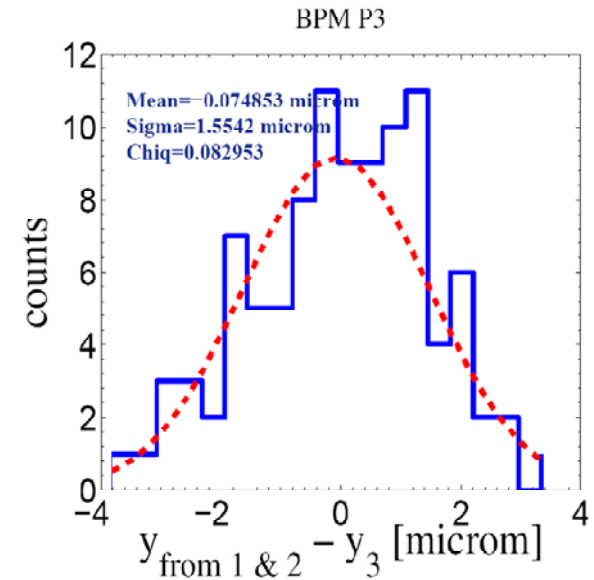
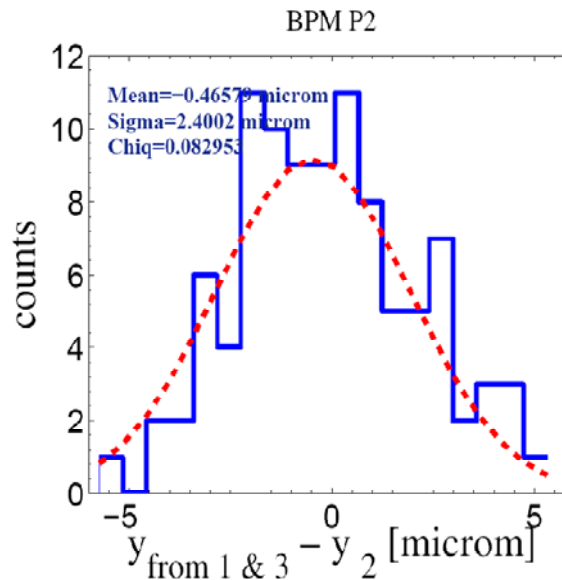
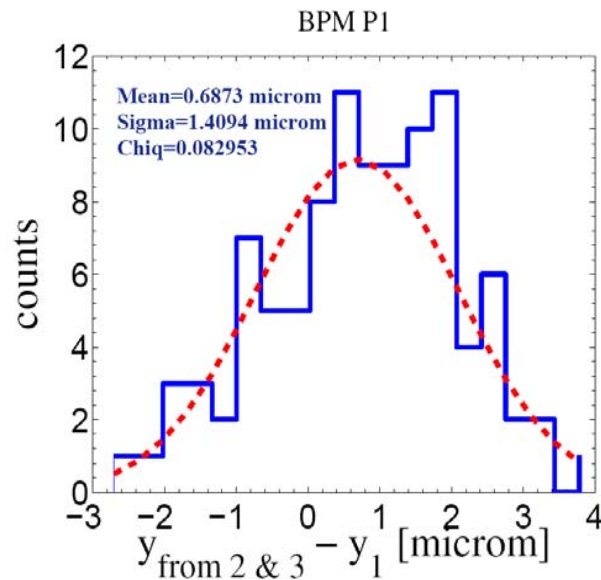

Basic review. Feed-forward correction

Kicker strength calculation

- Two BPMs (BPM1 & BPM2) in order to construct the transfer matrix
- Two kickers (K1 & K2) for vertical position (Y) and angle (Θ) correction
- Let $\begin{pmatrix} y_1 \\ \theta_1 \end{pmatrix}$ be the position and angle at K1 position before applying the correction

$$\begin{pmatrix} Y \\ \Theta \end{pmatrix} = \overbrace{\begin{pmatrix} 0 \\ \Delta \theta_2 \end{pmatrix}}^{\text{Kicker 2}}_{K_2} + \begin{pmatrix} R_{33} & R_{34} \\ R_{43} & R_{44} \end{pmatrix} \left[\overbrace{\begin{pmatrix} 0 \\ \Delta \theta_1 \end{pmatrix}}^{\text{Kicker 1}}_{K_1} + \begin{pmatrix} y_1 \\ \theta_1 \end{pmatrix} \right]$$

Kicks for correction $\begin{pmatrix} Y \\ \Theta \end{pmatrix} = \begin{pmatrix} 0 \\ 0 \end{pmatrix} \longrightarrow \begin{pmatrix} \Delta \theta_1 \\ \Delta \theta_2 \end{pmatrix} = \begin{pmatrix} -\frac{R_{33}}{R_{34}} & -1 \\ \frac{R_{44}R_{33} - R_{34}}{R_{34}} & 0 \end{pmatrix} \begin{pmatrix} y_1 \\ \theta_1 \end{pmatrix}$

Let δy and $\delta \theta$ be the correction residue, which propagates to the IP: $\begin{pmatrix} \delta y_{IP} \\ \delta \theta_{IP} \end{pmatrix} = \mathbf{R}_{IP} \begin{pmatrix} \delta y \\ \delta \theta \end{pmatrix}$

Tolerable residual error at IP (Goal B): $\delta y_{IP} \leq 5\% \sigma_y^* \approx 2 \text{ nm}$

Results of vertical position correction

Residual jitter propagation

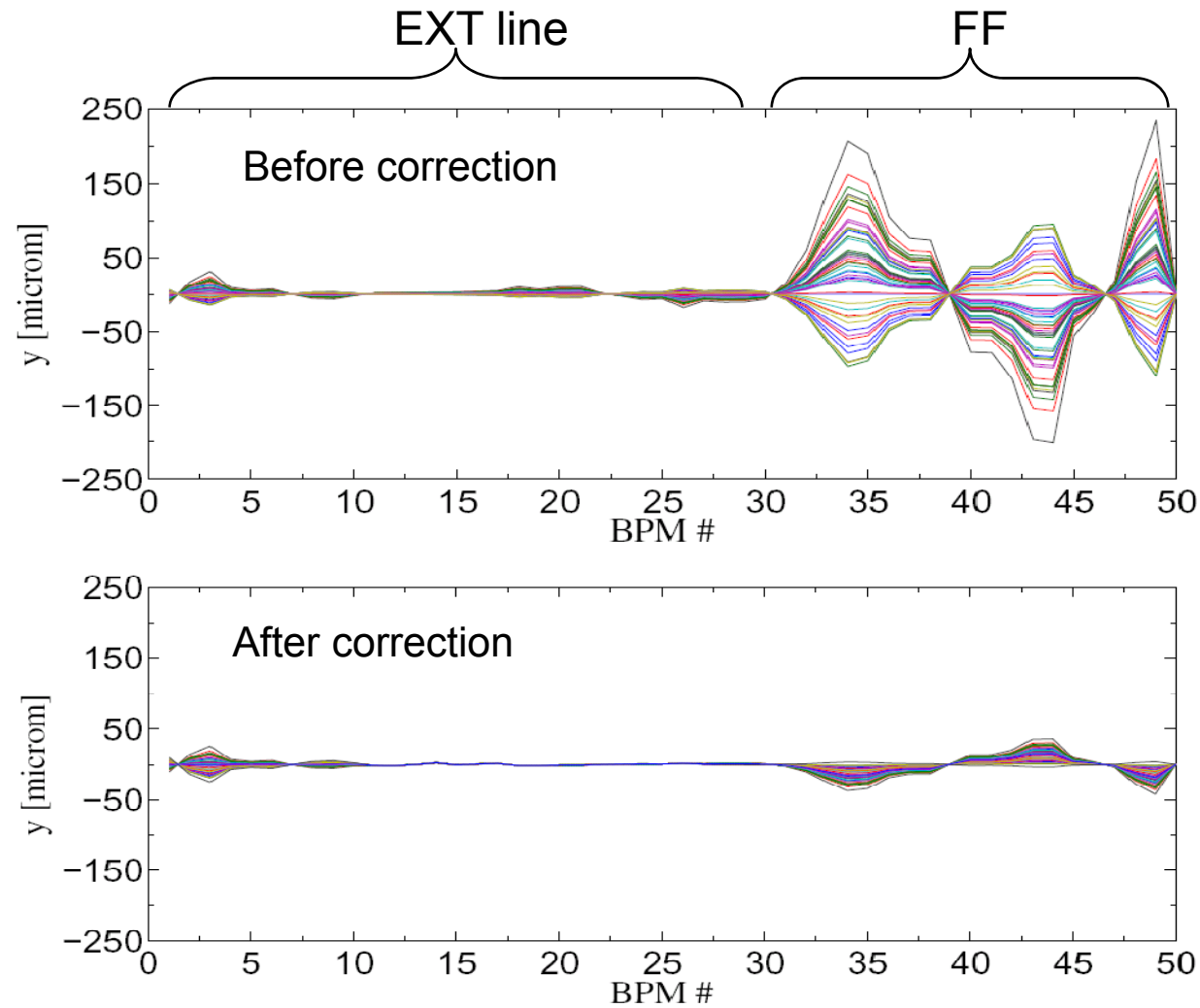

FONT BPMs:
BPM 9 (P1)
BPM 14 (P2)
BPM 19 (P3)

Results of vertical position correction

Residual jitter propagation

Zoom of the EXT line:

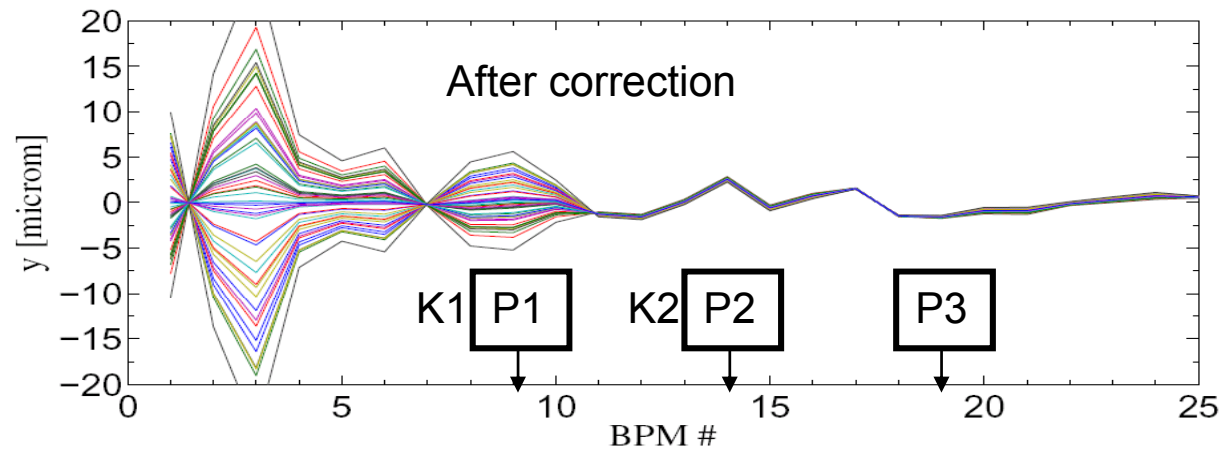
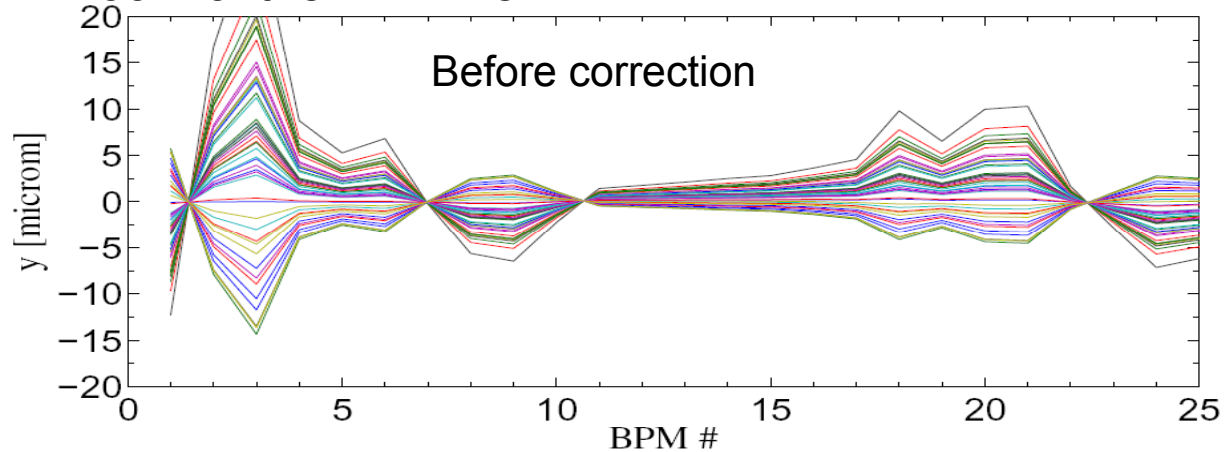

Jitter distribution at the IP

Assuming 1 μm BPM resolution and 0.5 % kicker strength error

Before correction

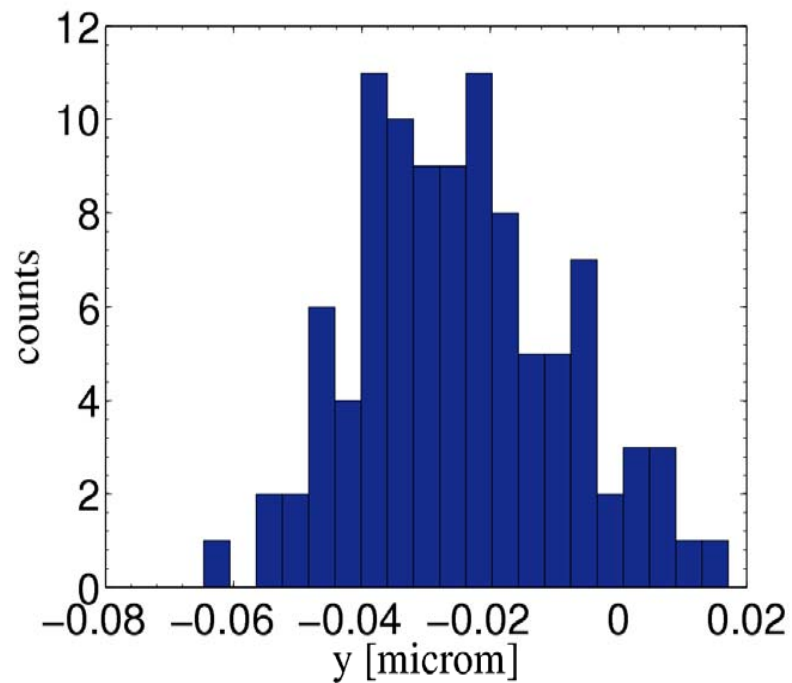

Mean = -0.0267 μm
Sigma = 0.0169 μm

After correction

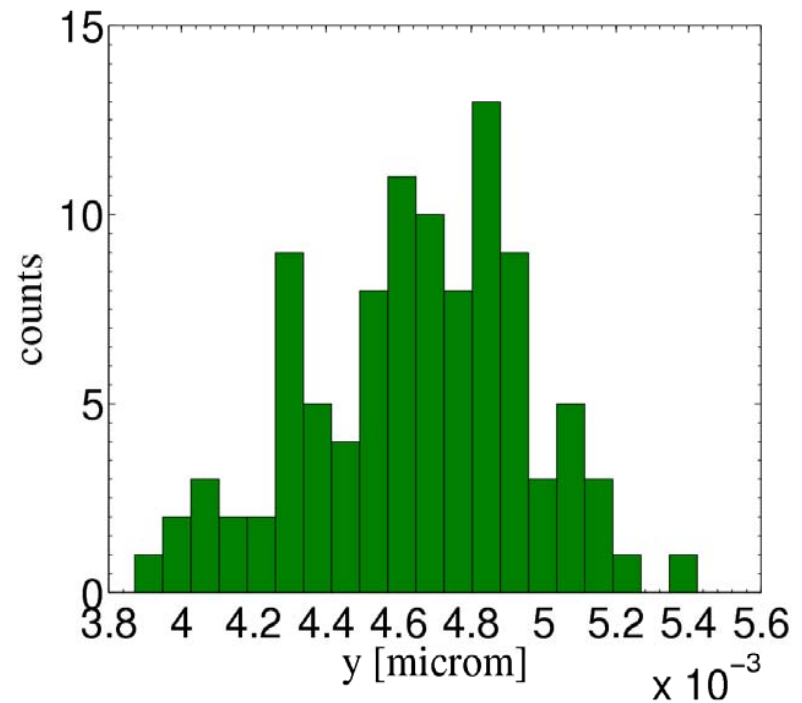

Mean = 0.00463 μm
Sigma = 0.000312 μm

Sensitivity to BPM resolution

Considering an initial random jitter distribution with a rms error of 40 % of the initial beam size

Each point is the average over 50 seeds

The error bars correspond to the standard deviation

Residual jitter at IP
vs BPM resolution:

If we consider that the residual jitter at the IP $< 5\% \sigma_y^*$ then BPM resolution must be better than $1 \mu\text{m}$. With $1 \mu\text{m}$ BPM resolution a control position $\sim 10\% \sigma_y^*$ may be feasible

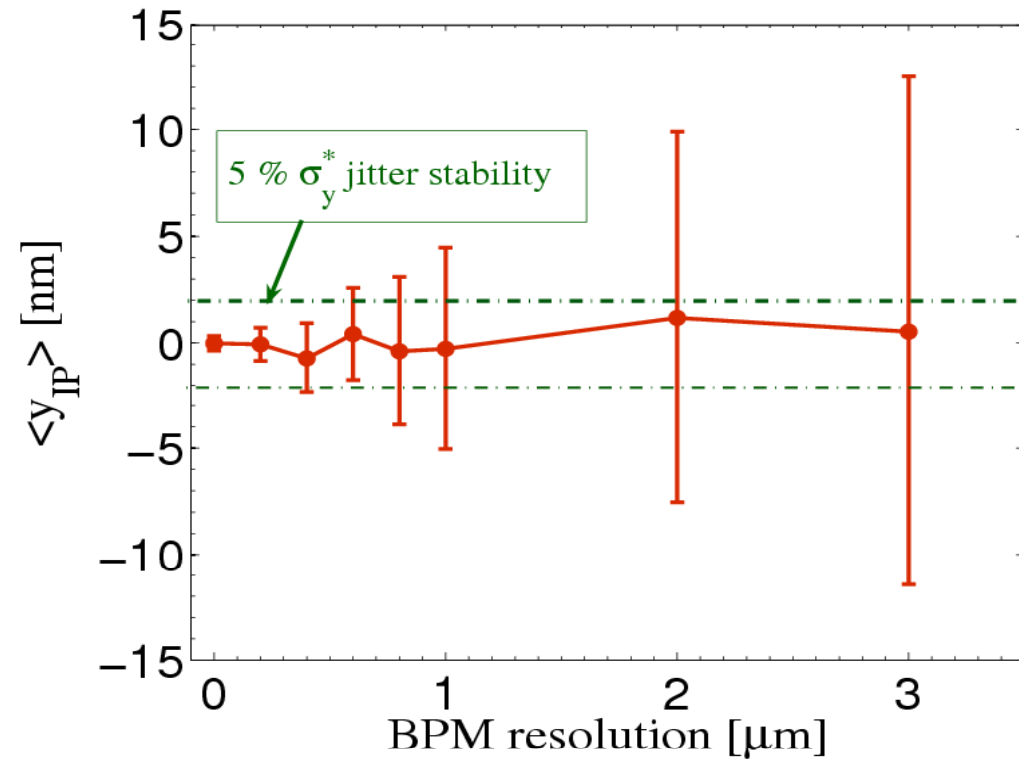

Sensitivity to kicker strength error

Considering an initial random jitter distribution with a rms error of 40 % of the initial beam size

Each point is the average over 50 seeds

The error bars correspond to the standard deviation

Residual jitter at IP
vs kicker strength error
(FB gain error):

In this case we obtain that the mean value of the residual jitter is practically constant, and the standard deviation increases as the kick strength error. Tolerable kick error < 10 % of the kick angle

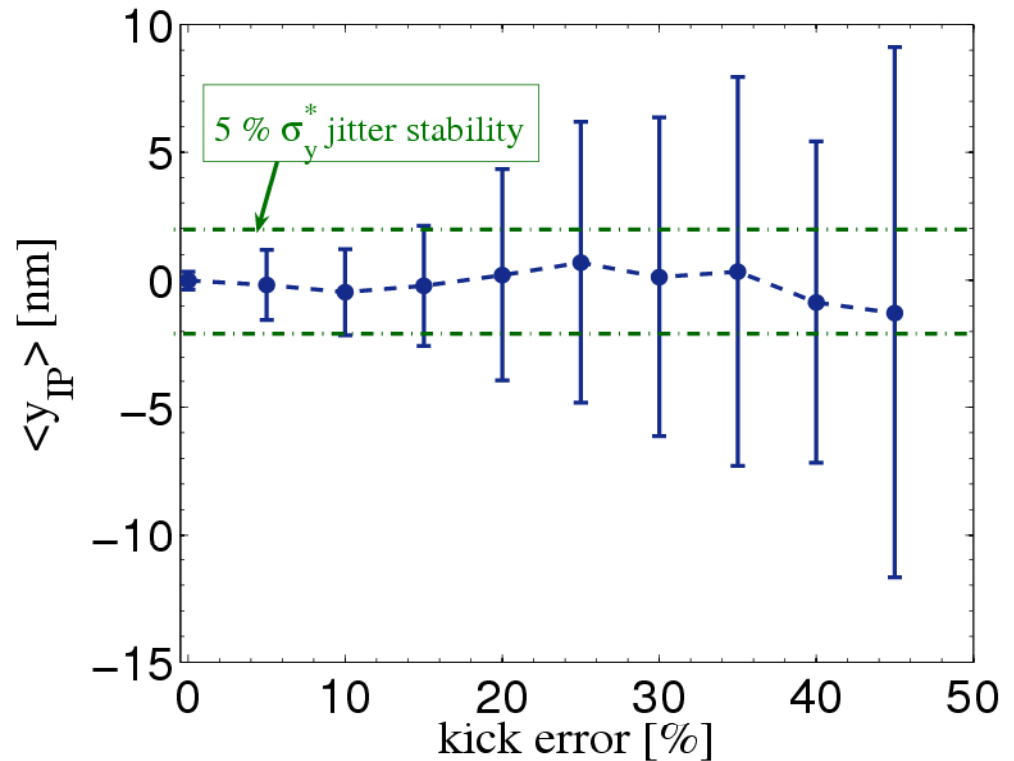

FB correction algorithms

FF and FB using the same kicker and BPM pairs. Interesting test option!

Pilot bunch algorithm: all bunches in a train are corrected using the same FB signal obtained from the first, pilot bunch

Two parallel FB systems for independent correction for angle and position

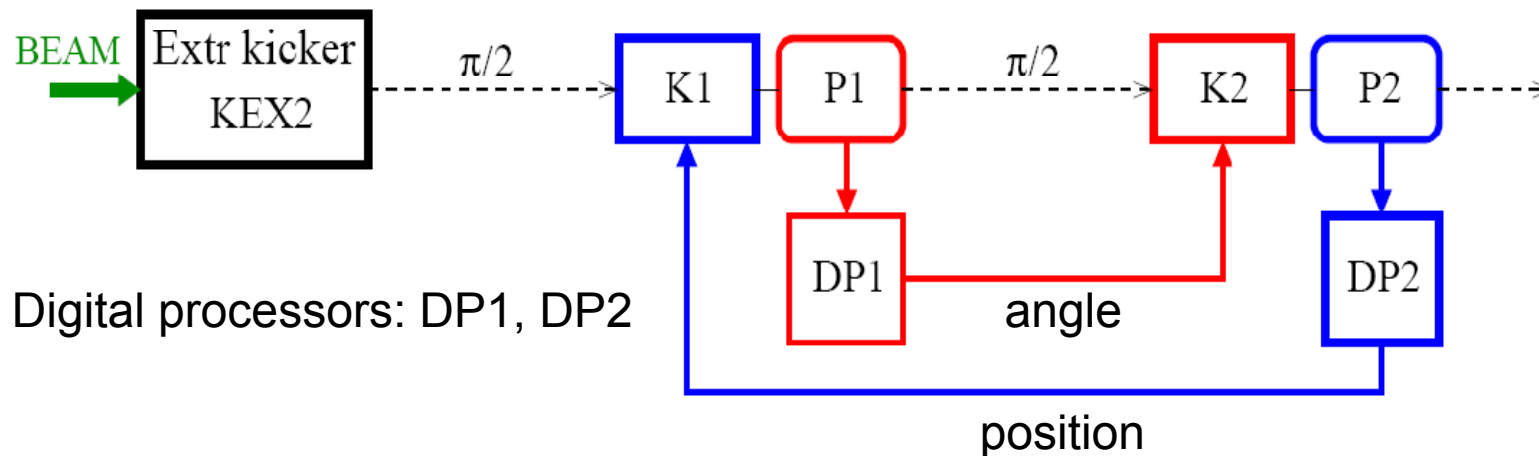

Digital processors: DP1, DP2

Time of flight P2-K1=10.65 ns

Time of flight P1-K2= 8.68 ns

FB correction algorithms

Schematic for coupled angle and position correction

[More details: A. Kalinin, "A Vision of the ATF2 Feedback and Feed-Forward Systems", FONT internal note, February 2008]

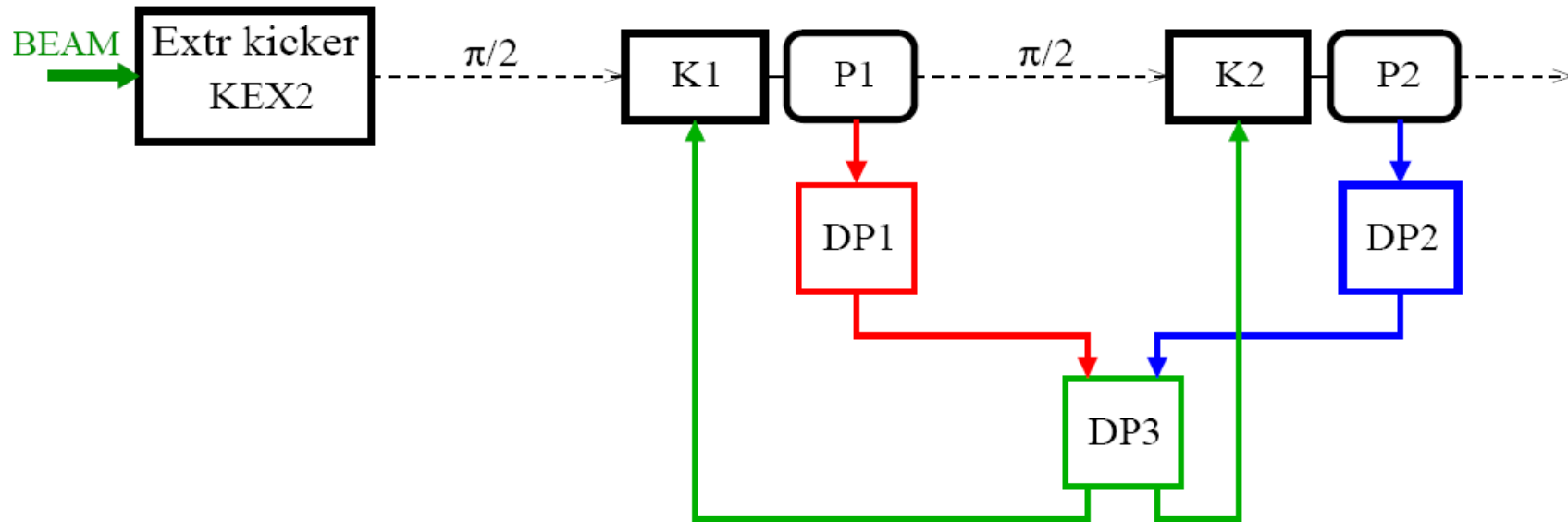

This option could be a good solution to reduce correction errors coming from the y - y' coupling

Adding different weights for simultaneous angle and position correction

FB correction algorithms

A third pickup P3 allocated downstream of P2, at $\pi/2$ phase advance, as witness BPM

In addition P3 also allow us the possibility to implement a 'classical' FB test

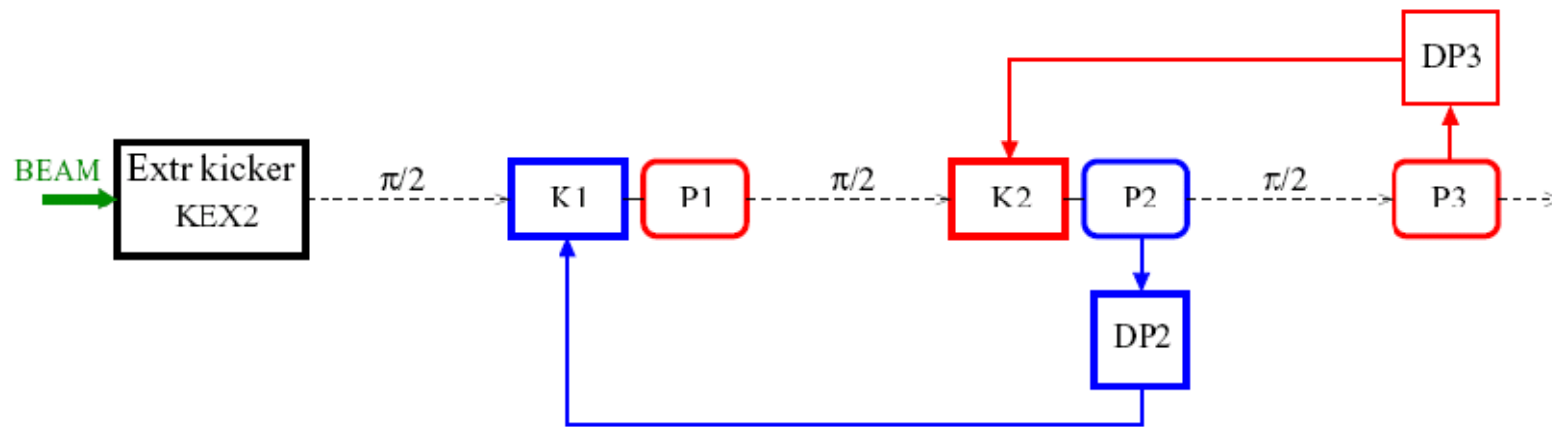

Time of flight P2-K1 = 10.65 ns

Time of flight P3-K2=10.53 ns

Summary and ongoing studies

- We have presented the layout of an intra-train feed-forward/feedback system to be placed in the extraction line of ATF2 (in the context of the FONT study)
 - Optimum BPM and kicker positions
 - Study of the necessary BPM and kicker parameters to show the feasibility and accuracy of bunch-to-bunch fast jitter correction (FB system latency budget ~ 150 ns)
- The necessary hardware is currently being developed and tested. The FONT FB hardware can be carried over to FF.
- A Placet-octave based model of the FONT system in the ATF2 beam line has been set up. This model allows us to perform beam dynamics tracking simulations with bunch-to-bunch jitter correction, including element misalignments and GM.
- Here we have shown results of simulations of jitter correction for single bunch mode
- The sensitivity to BPM resolution and kicker strength error has been studied
- Simulations for multibunch mode (20- bunch train) are in progress
- Study of different FB system algorithms, which have to be tested by means of simulation studies (realistic model including errors, eg. finite BPM input noise, BPM zero offset, error in the FB gain, crosstalk errors)

Reservoir

Design of FONT at ATF2

Kicker K1 & BPM P1

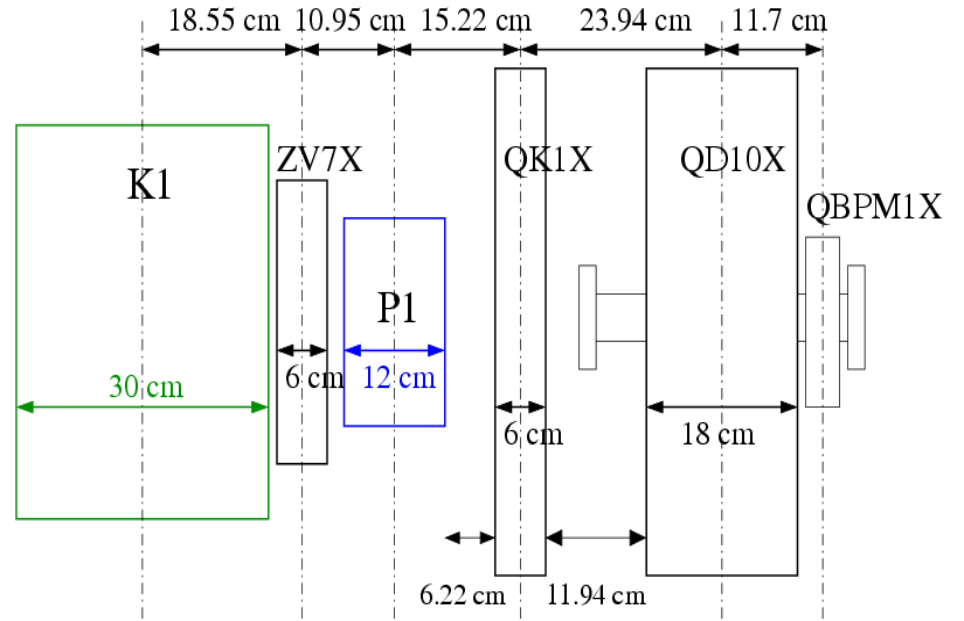
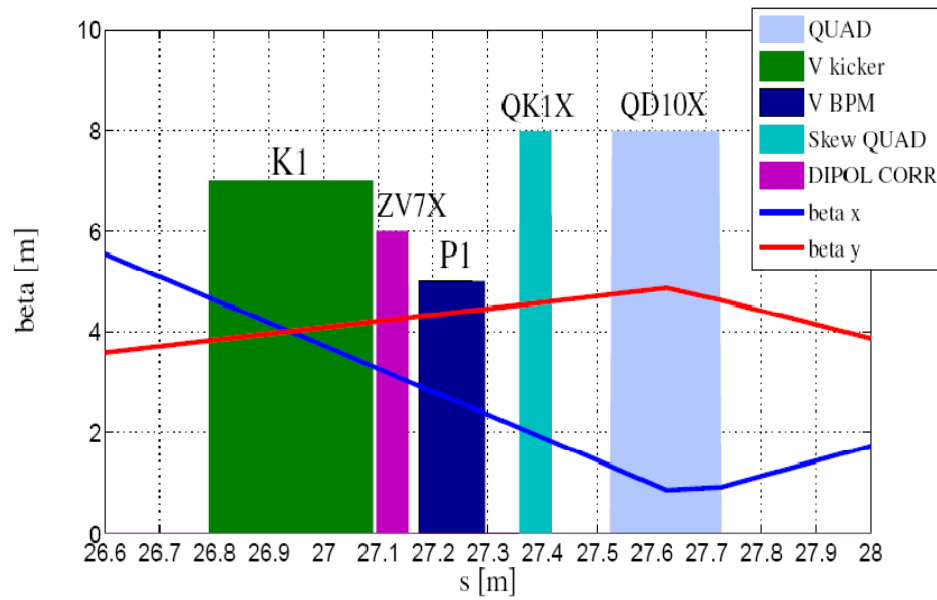

scale: 1/8 inches (drawing) = 2 cm (beamline)

Warning: Flanges not considered !

Reservoir

Design of FONT at ATF2

Kicker K2, BPMs P2

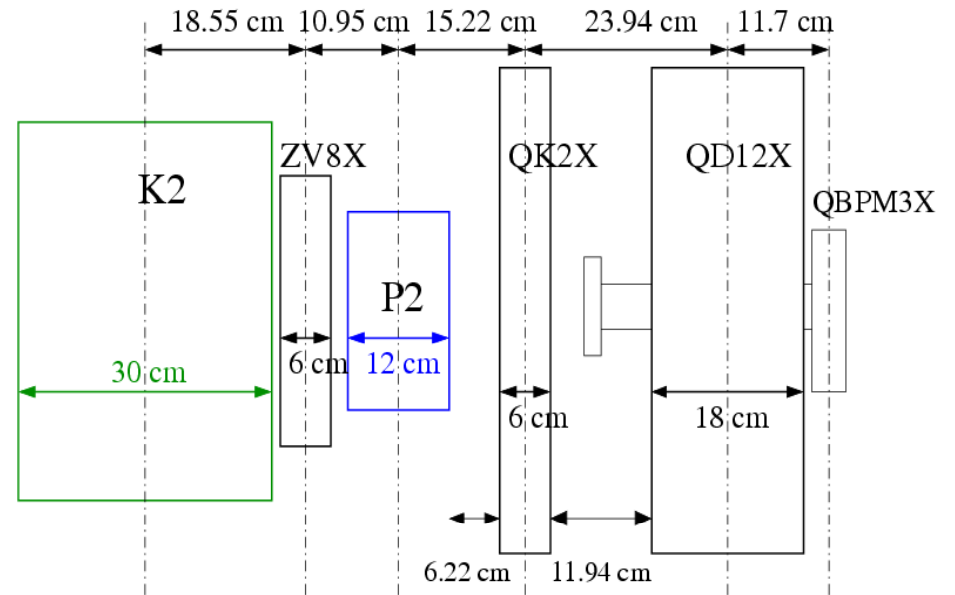
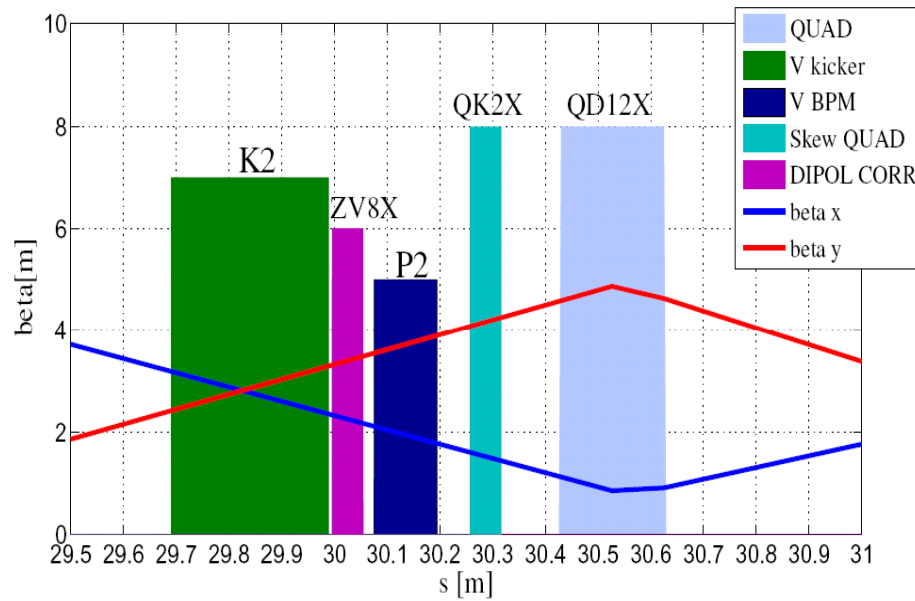

scale: 1/8 inches (drawing) = 2 cm (beamline)

Warning: Flanges not considered !

Reservoir

Phase advance between kickers

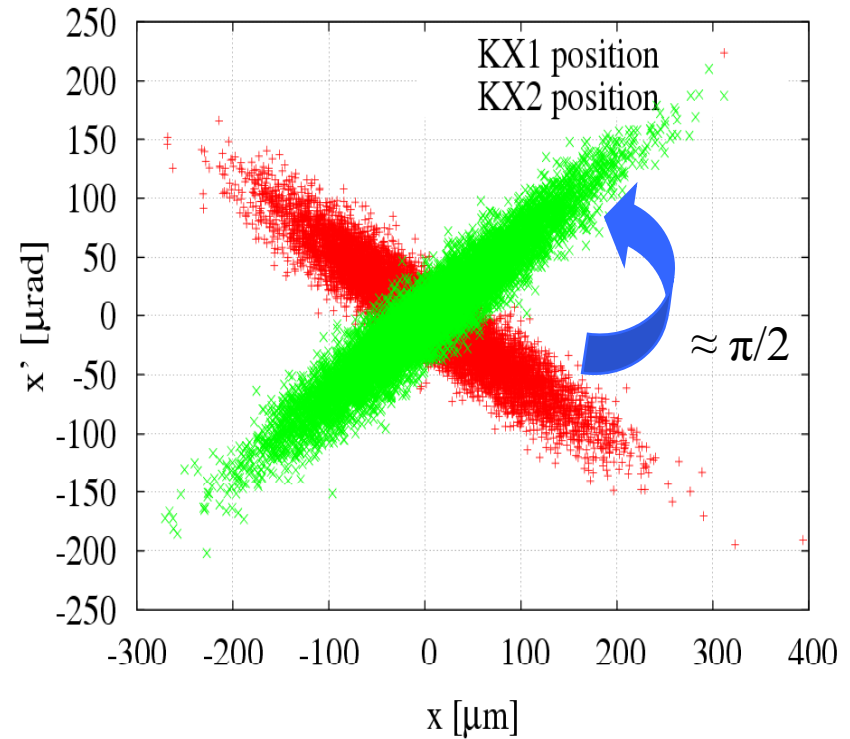
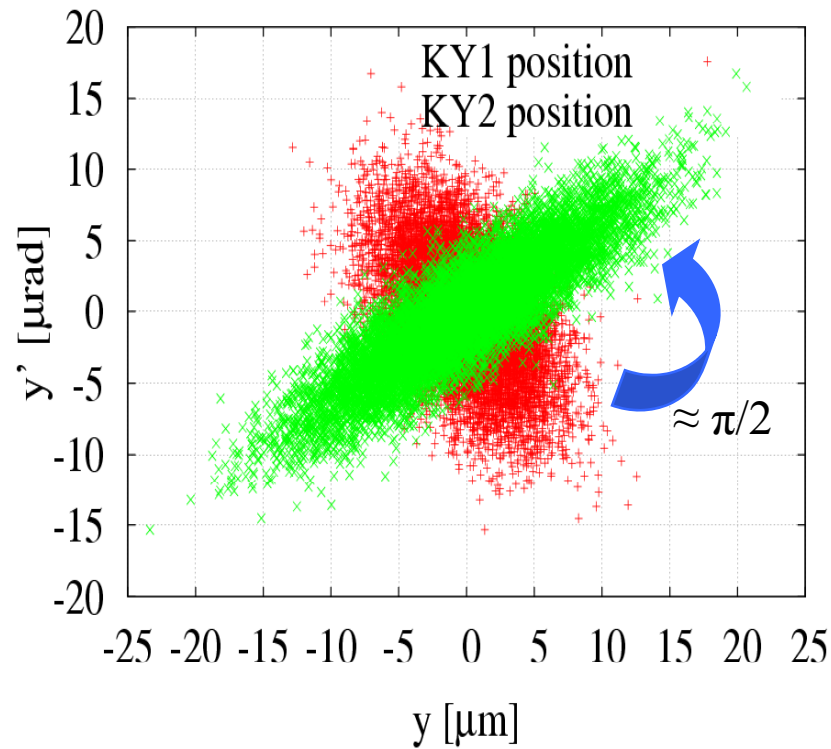

Phase advance between kicker pairs of $\approx \pi/2$