

# Silicon Sensors for LumiCal Status

Wojciech Wierba,  
J. Błocki, W. Daniluk, E. Kielar, J. Kotuła,  
A. Moszczyński, K. Oliwa, B. Pawlik, L. Zawiejski  
Institute of Nuclear Physics PAN  
Cracow, Poland

EUDET Annual Meeting, Amsterdam, 06-08.10.2008



# Sensor Prototype

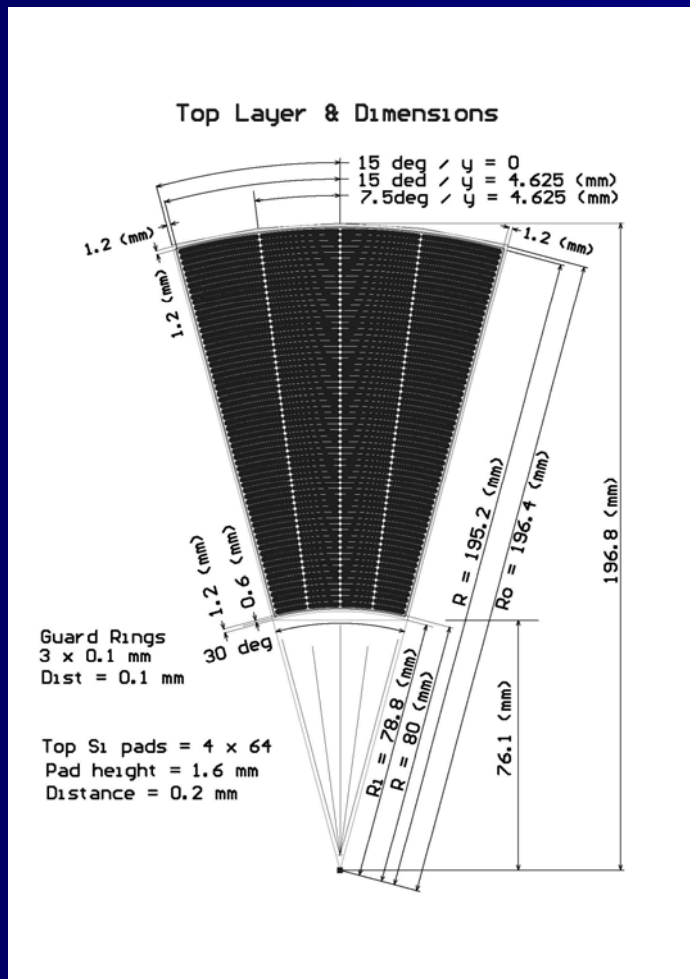

- Masks for prototypes ready in Hamamatsu (~20 k€) and will be kept for 3 years without add. costs.
- Sensors order near to submit (~900 €/tile if 40 pcs. ordered).
- Separate orders.

# Detailed design of the masks

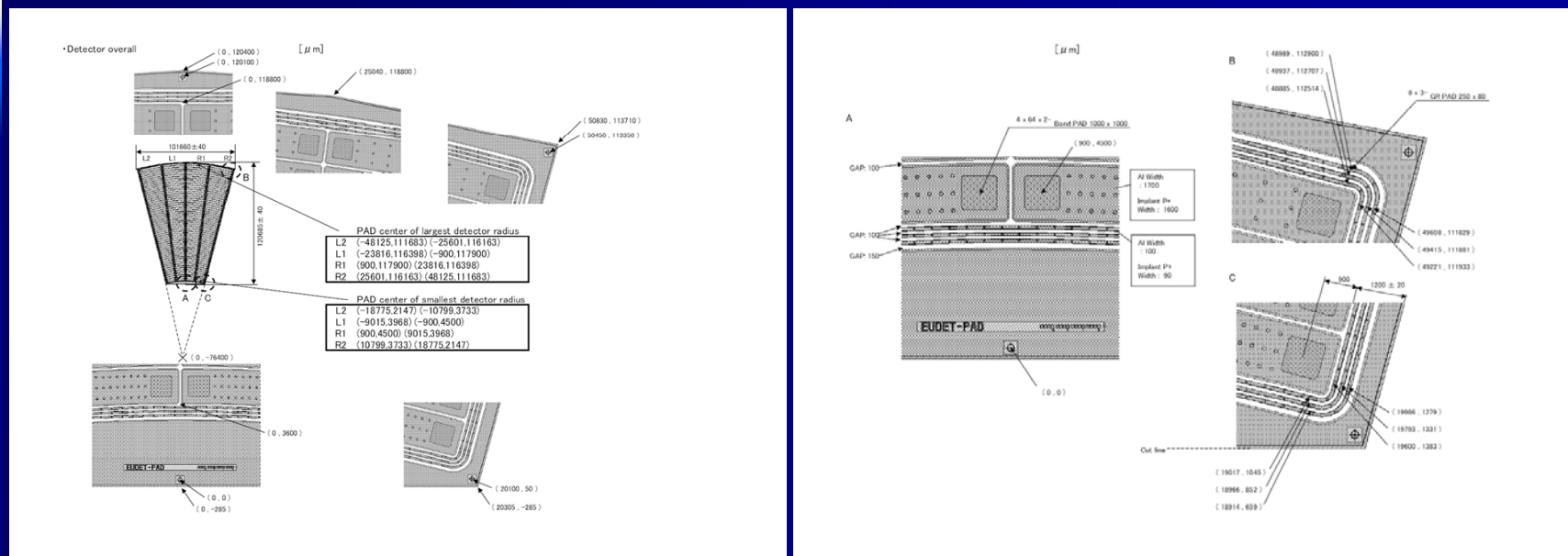

- N-type silicon, p<sup>+</sup> strips, n<sup>+</sup> backplane,
- Crystal Orientation <100>
- 320  $\mu\text{m}$  thickness  $\pm$  15  $\mu\text{m}$
- Strip pitch: 1800  $\mu\text{m}$
- Strip p<sup>+</sup> width: 1600  $\mu\text{m}$
- Strip Al width: 1700  $\mu\text{m}$

# Sensor half plane

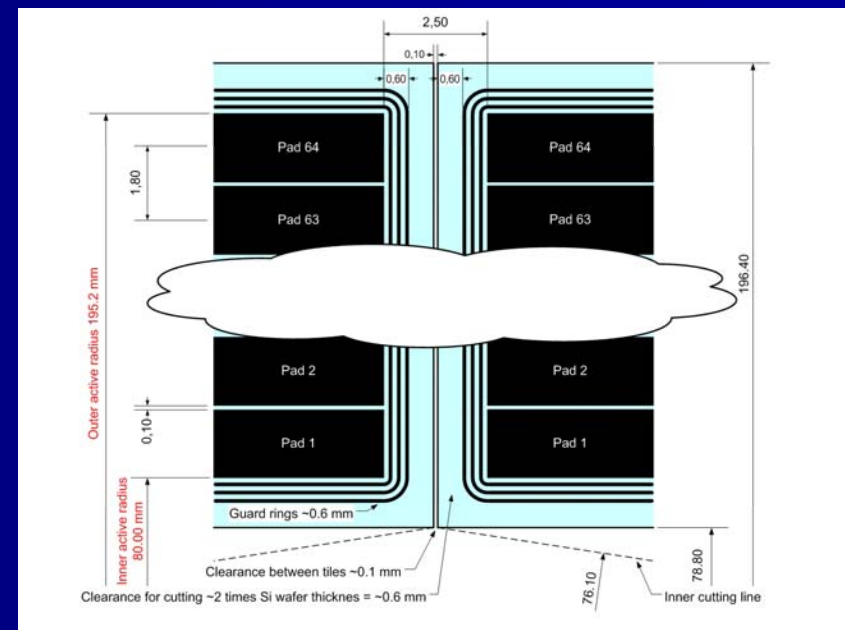
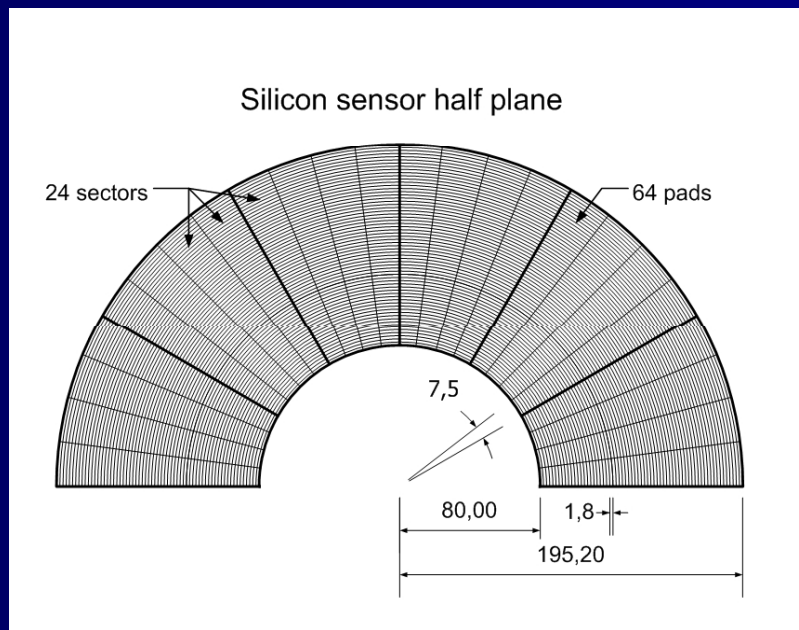

- 6 tiles of 4 sectors on one half plane
- 6 inch wafers
- MC simulations of the gap = OK

# Fan out

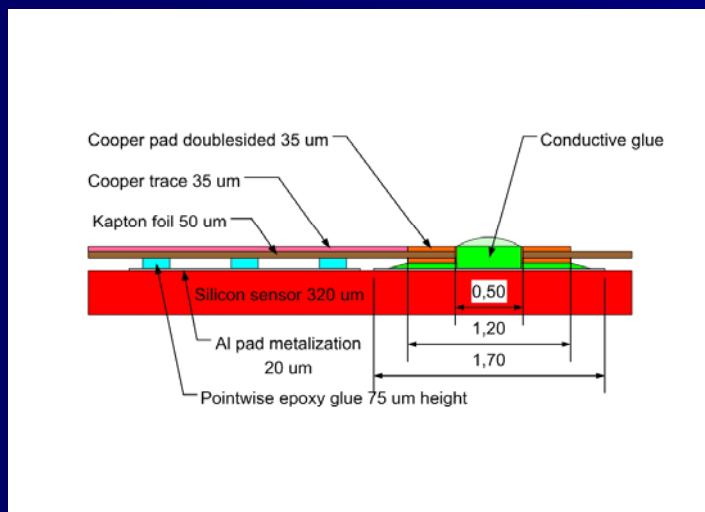
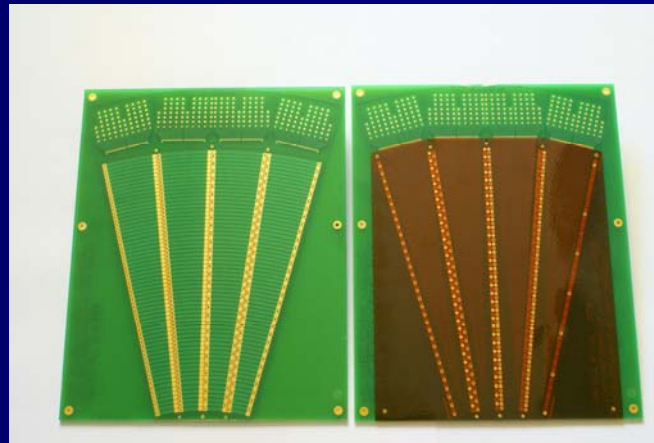
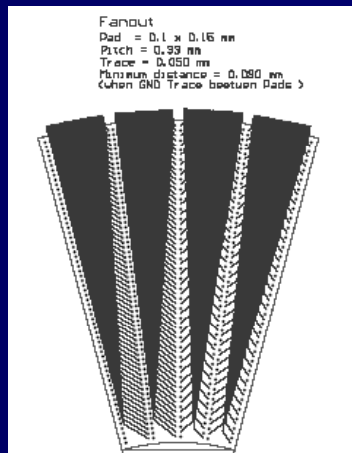

- Wire bonding not possible.
- Dummy 'sensor'.
- Searching for right conductive glue.

# Summary

- Sensor prototypes hopefully will be ready by the end of this year (depend on 'speed' of administration).
- We have agreed with Hamamatsu to have separate orders based on one masks design (already paid) and counted as one order (price dependence on amount of tiles ordered).
- Hamamatsu has reserved for us some (more than 40) silicon tiles from silicon factory.
- We have to find better factory to produce fan out on Kapton foil.
- Searching for the proper electrically conductive glue is a crucial point.