

Worldwide Study of
the Physics and Detectors

for Future Linear
 e^+e^- Colliders

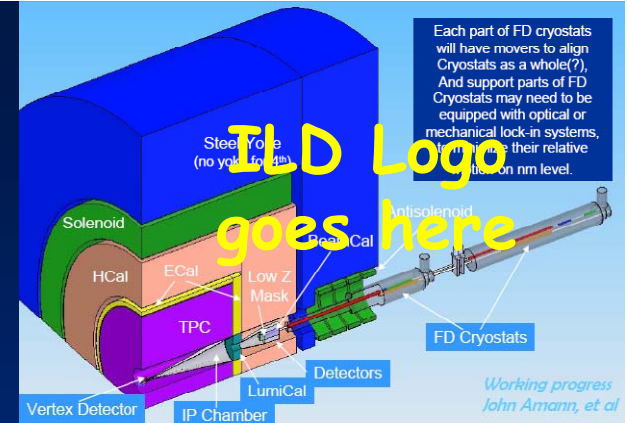

LCTPC issues for the ILD LOI



LCTPC MOA to R&D/design a TPC: Status August 2008

Americas

BNL ✓
Carleton ✓
Montreal req
Victoria ✓
Triumf ✓
Cornell ✓
Indiana ✓
LBNL prom
Louisiana Tech req

Observer groups

Iowa State
MIT
Purdue
Yale
TU Munich
UMM Krakow
Bucharest

Asia

Tsinghua ✓
CDC:
Hiroshima req
KEK ✓
JAX Kanagawa req
Kinki U ✓
Nagasaki InstAS req
Saga ✓
Kogakuin ✓
Tokyo UA&T req
U Tokyo req
Minadano SU-IIT req

Signatures 24
Promised 3
Requested 11
New groups welcome

Europe

Brussels ✓
LAL Orsay req
IPN Orsay req
CEA Saclay ✓
Aachen ✓
Bonn ✓
DESY ✓
EUDET ✓
U Hamburg ✓
Freiburg req
Karlsruhe req
MPI-Munich ✓
Rostock ✓
Siegen prom
NIKHEF ✓
Novosibirsk ✓
St. Petersburg prom
Lund ✓
CERN ✓

Additional Questions from IDAG (Draft)

June 22, 2008

IDAG wishes the proponents of the 3 LOI's to address the following points in their LOI document:

- (1) Sensitivity of different detector components to machine background as characterized in the MDI panel.
- (2) Calibration and alignment schemes.
- (3) Status of an engineering model describing the support structures and the dead zones in the detector simulation.
- (4) Plans for getting the necessary R&D results to transform the design concept into a well-defined detector proposal.
- (5) Push-pull ability with respect to technical aspects (assembly areas needed, detector transport and connections) and maintaining the detector performance for a stable and time-efficient operation.
- (6) A short statement about the energy coverage, identifying the deterioration of the performances when going to energies higher than 500 GeV and the considered possible detector upgrades.
- (7) How was the detector optimized: for example the identification of the major parameters which drive the total detector cost and its sensitivity to variations of these parameters.

1. All sub-detectors

- overall sizes, especially outer and inner diameters and total length
- total weight
- support method/mechanism
- total cross section of cables and pipes (gas and cooling material) and the maximum diameter among them in order to determine gaps between sub-detectors for them
- location of front-end electronics
- route of cable and pipe extraction, i.e. where and how are they extracted ?
- total electric power consumption
- alignment method, e.g. laser system- how to inject a laser beam, where the laser system is installed, etc.

3. TPC

- How much is the field uniformity ?
 - a LCTPC note is available at <http://www.mppmu.mpg.de/~settle/tpcbfieldnote3L.pdf>.
 - field reproducibility during push pull
 - anti DID field is not constant, i.e. it will be varied during experiments
 - requires precise field measurement and calibration at Z-pole

We are planning to have a TPC talk in the subdetector technology session.

The purpose is

- a. to summarize the R&D status and present plans for LOI and toward the real detector.
- b. to present alignment and calibration schemes, and
- c. to present basic engineering design (including supports)

It is important that this is NOT intended to present a summary of all the specific and existing R&Ds.

For the presentation in Cambridge we hope that you can summarise the state of the subdetector you are representing with a clear focus on the letter of intent. Things which probably should be covered are

- which resolutions can be realistically achieved
- which big risks exist - as far as we are currently aware - for this particular technology / system
- are there obvious options which we should consider within ILD - that is, do we have a clear technological candidate, or are there more than one competing technologies.
- which parameters are from a subdetector point of view most relevant in an optimization process
- how well is the costing of the system understood
- are there major constraints from the subsystem on the detector integration etc (for this see also the questionnaire which was sent to you by the MDI group some time ago).

Many questions to answer for the LOI. An attempt to synthesize them into one list is →

List of questions for this talk:

LCTPC issues for the LOI

1. Performance goals
 - R&D plans/options/risks
 - How was the subdetector optimized?
(e.g., using resolution, costing?)
2. Sensitivity to backgrounds
3. Calibration and alignment schemes
4. Engineering model for LOI and simulation
 - Size, weight, support, dead areas
 - Endplate, electronics, power
 - Fieldcage, chamber gas
5. Push-pull ability
6. \sqrt{s} coverage
7. Final comment

N.B. These are suggestions for the LOI, and we expect to be iterating on them during the next few weeks...

1. LCTPC performance goals

- continuous 3-D tracking, easy pattern recognition throughout large volume
- ~98-99% tracking efficiency in presence of backgrounds
- time stamping to 2 ns together with inner silicon layer
- minimum of X₀ inside Ecal (~3% barrel, ~15% endcaps)
- $\sigma_{pt} \sim 50 \oplus \text{diff} \mu\text{m} (r\phi)$ and $\sim 500 \mu\text{m} (rz)$ @ 4T
- 2-track resolution $< 2\text{mm} (r\phi)$ and $< 5\text{mm} (rz)$
- dE/dx resolution $< 5\%$ \rightarrow e/pi separation, e.g.
- design for full precision/efficiency at 10 x estimated backgrounds

modulo angles:

```
1) As a function of drift-distance Ld(drift), the expression for the  
rphi point resolution is, as you know,  
  
sigmapoint2 = sigma02 + Cd2/Neff * Ld(drift)  
  
Proposal 1) on point resolution:  
  
=> sigma02 = (50micron)2 + (900micron*sin(phi))2  
(where phi is the local azimuthal angle of track wrt the padrow)  
  
=> Cd2/Neff = 2.52 * (22/sin(theta))2 * h * (6mm) = (5.3 micron/sqrt(cm))2 * (6mm/h) * sin(theta)  
(this is for B=4T which we favor, h is the pad height=pad-row pitch in mm,  
theta is the polar angle)  
  
=> sigmaz(0) = sqrt(400micron**2 + z(cm) * (80micron/sqrt(cm))**2)
```

1. LCTPC performance goals

- R&D plans/options

Present goals based on results from small prototypes using cosmics or beams at KEK, DESY, CERN. Three options left →

Keisuke Fujii

$\sigma_0=23\mu\text{m}$, $Cd=49\mu\text{m}/\text{cm}$

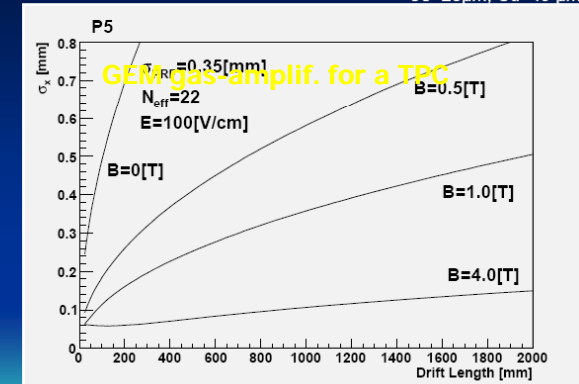

11/09/2008

Ron Settles MPI-Munich/Desy
LCTPC Meeting Sendai

5

Examples of Prototype TPCs

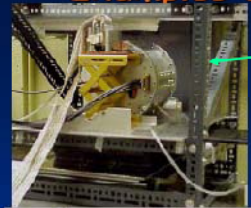

Carleton, Aachen, Cornell/Purdue, Desy (n.s.) for $B=0$ or $1T$ studies

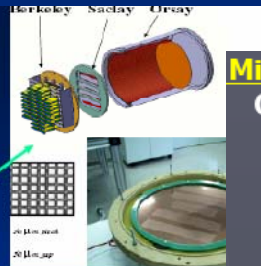

Saclay, Victoria, Desy (fit in 2-5T magnets)



Karlsruhe, MPI/Asia, Aachen built test TPCs for magnets (not shown) other groups built small special-study chambers



Munich/D Beijing BILCWU/ Tracking Review
LCTPC Design, R&D Issues

5 February 2007

11

MicroMegas TPC with resistive anode Carleton TPC (M. Dixit et al., 2007)

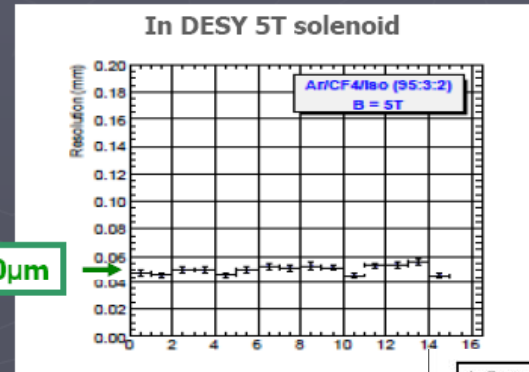

Silicon Pixel Readout for a TPC

A 5 cm³ TPC (two electron tracks from ⁹⁰Sr source)

$B = 0.2 T$

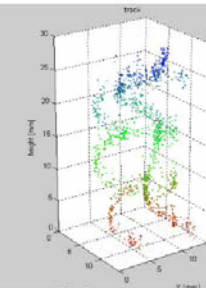
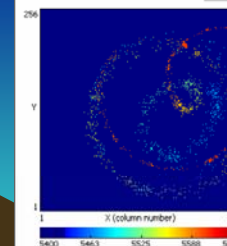

Ron Settles MPI-Munich/DESY
LCTPC planning for the LOI

11/09/2008

6

1. LCTPC performance goals

- R&D plans/risks

...to be verified (or revised) after tests on the Large Prototype:

Consolidation Phase TPC Large Prototype Beam Test at DESY

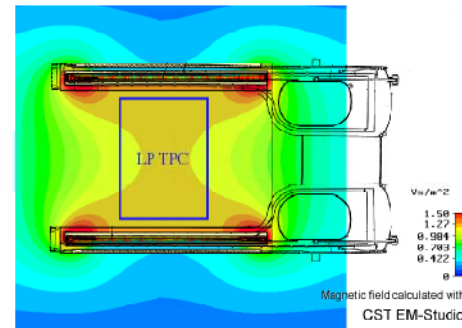
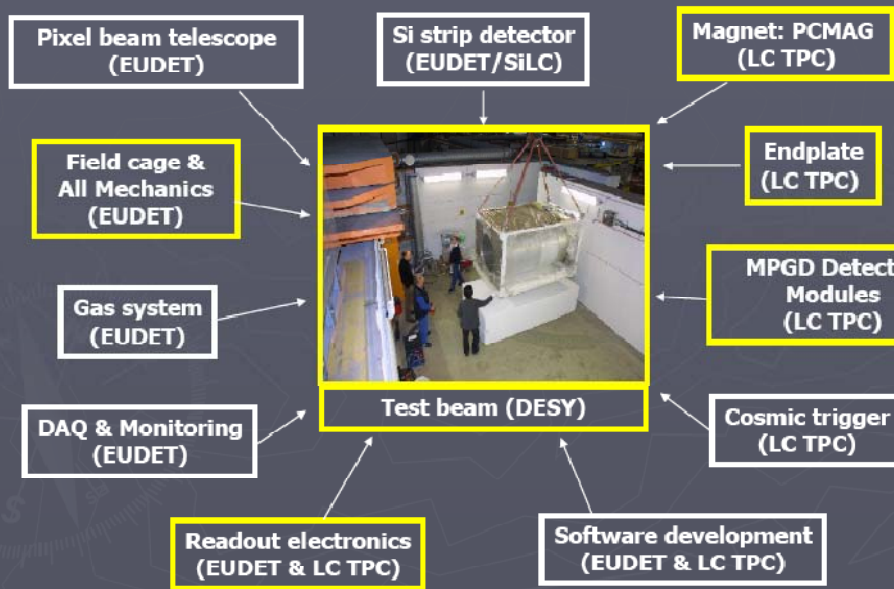

infrastructure for TPC R&D, available for many researcher groups



11/09/2008

Ron Settles MPI-Munich/DESY
LCTPC planning for the LOI

1. LCTPC performance goals

- R&D plans/risks (cont'd)

- From the LCTPC MOA:

The LP tests will enable us to choose the best technology for constructing a real detector...

Workpackage (0) TPC R&D Program
Workpackage (1) Mechanics
a) LP endplate structure with panels
b) Fieldcage
c) GEM panels
d) Micromegas panels
e) Pixel panels
f) Panels with charge-dispersion-anode
Workpackage (2) Electronics
a) Standard RO/DAQ system for LP
b) CMOS RO electronics
c) Electronics for LCTPC
Workpackage (3) Software
a) LP software +simul./reconstr.framework
b) LCTPC simulation/perf./backgrounds
c) Full detector simulation/performance
Workpackage (4) Calibration
a) Field map for the LP
b) Alignment
c) Distortion correction
d) Radiation hardness of materials
e) Gas/HV/Infrastructure for the LP

- Our basic approach for the ILD LOI has been to use optimistic assumptions as goals for TPC resolution, material, etc. These goals are based on various R&D results (small-prototypes), continuing efforts (large-prototype/electronics/software developments) by LCTPC groups. So the only risk is that some goals turn out to be too aggressive.

1. TPC Performance goals

- How was the subdetector optimized?
- ILD subdetectors must be optimized coherently by present optimization studies, \therefore for the TPC, this means:

$$\sigma_{pt} \sim 50 \oplus \text{diff} \mu\text{m} (r\phi)$$

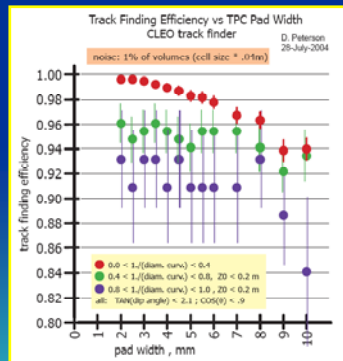

Physics determines detector design

★ Momentum $d(1/p) \sim 3 \times 10^{-5}/\text{GeV}$ all tracking
 $10 \times 10^{-5}/\text{GeV}$ TPC

★ Tracking efficiency $\sim 99\%$ to help PFA reach $dE/E \sim 0.25/\sqrt{E}$

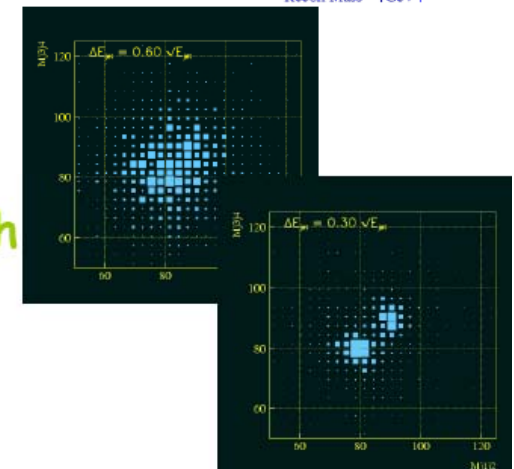
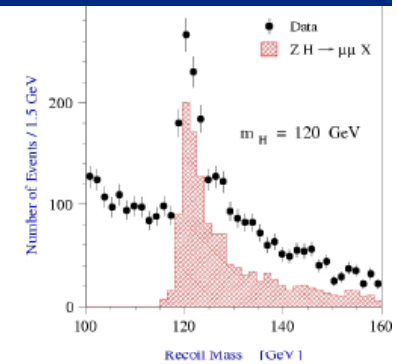

1. TPC Performance goals

- How was the subdetector optimized? (e.g., using resolution, costing?)
- Resolution: previous slide.
- Costing: The TPC cost is nearly independent of the size for the different ILD models. Previous TPC estimates at ~ 25 M€ can only become reliable after the design decisions. For earlier ILD-detector estimates at ~ 500 M€, cost drivers are the magnet and the calorimeters, so the TPC cost is not an issue for the optimization.

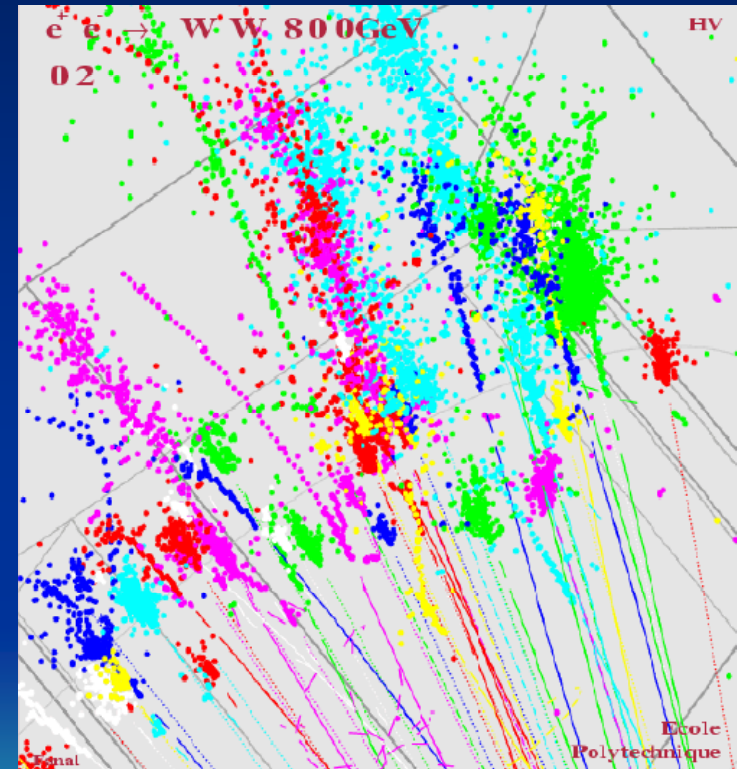

2. LCTPC sensitivity to backgrounds

See talk#3 in opening session today by Dr. Adrian Vogel. Status at LCWS07:

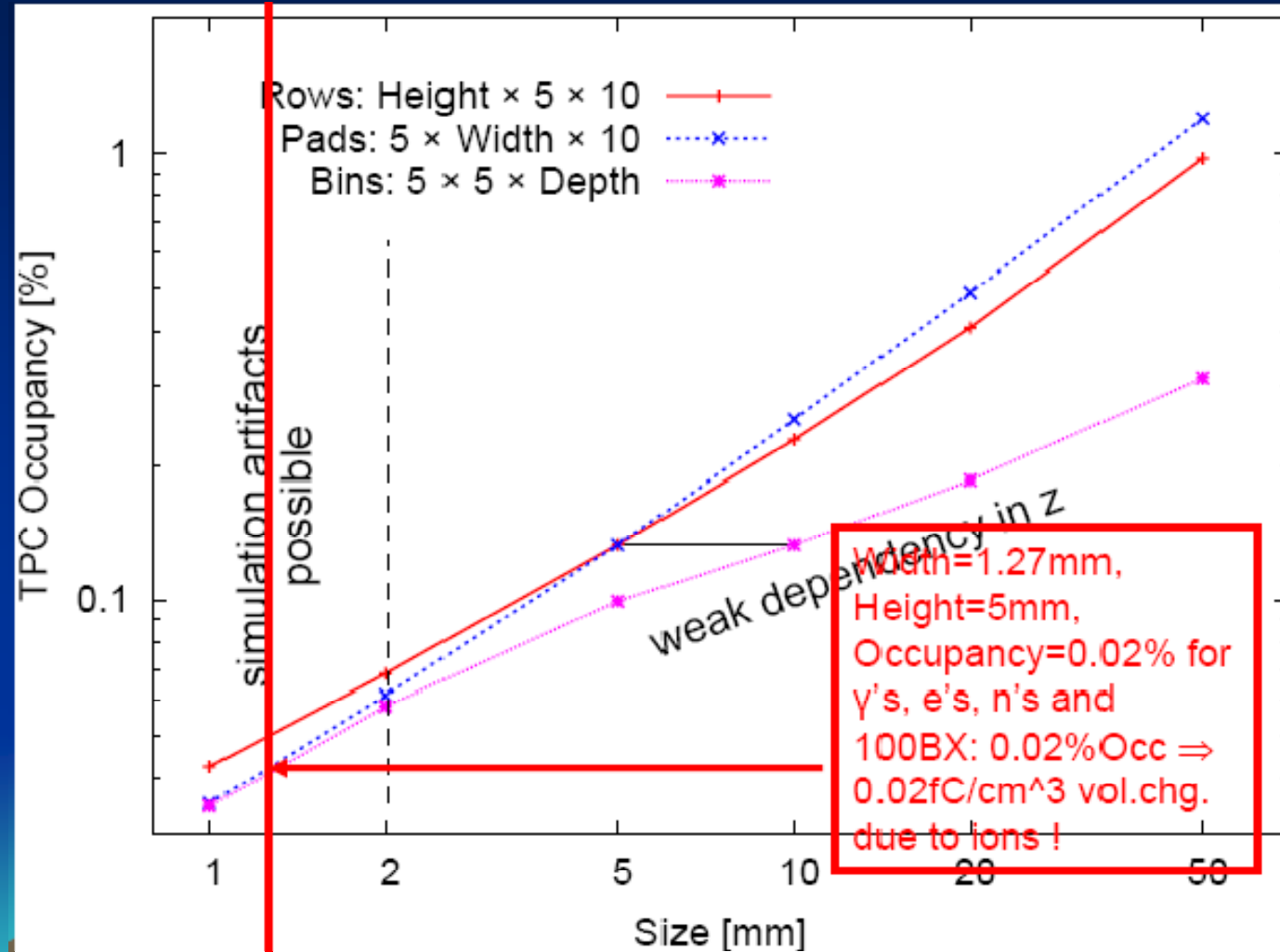

3. LCTPC calibration and alignment schemes

TPC issues:

- **Space charge due to ion "backflow"**
 - **In TPC volume due to positive ions:** see previous slide.
 - **At gas-amplification plane:** eliminate ion sheets w/ gating plane .
- **B-field:** no requirement on homogeneity, only on accuracy of field map. **See LC Note that Werner Wiedenmann and I finally finished:**

LC-DET-2008-002
at <http://www-flc.desy.de/lenotes>
ILC-NOTE-2008-048
at <http://ilcdoc.linearcollider.org/>

The Linear Collider TPC: Revised Magnetic-field Requirements¹

R. Settles²
Max-Planck-Institut für Physik, Föhringer Ring 6, D-80805 Munich, Germany

W. Wiedenmann³
c/o Physics Department, University of Wisconsin at Madison, CERN PH
Divison, CH-1211 Geneva, Switzerland

August 2008

Aleph field map
was good enough
but can be
improved on to
increase B-map
accuracy for the
LCTPC.

3. Calibration and alignment schemes (cont'd)

Calibration tools for all tracking subdetectors:

- Z-peak running, 10/pb beginning of year, 1/pb during (after push-pull e.g.). Internal alignment of each tracking subdetector, then between detectors. (See http://wisconsin.cern.ch/~wiedenma/TPC/Distortions/Cern_LC.pdf for examples of calibrating the Aleph TPC.)
- Physics data at \sqrt{s} also powerful (e.g. $e+e\rightarrow\mu+\mu^-$, radiative-returns to the Z)
- B-field map (see LC Note, preceding slide)
- Hall/NMR probes on magnet and field cage
- Laser calibration system
- TPC: time-stamping using silicon layers

4. LCTPC engineering model for LOI and simulation

- Size, weight, support, dead areas
- Size to be decided at this optimization meeting.
 $\varnothing_{\text{outer}} \sim 3.6\text{m}$, $\varnothing_{\text{innerILD2}} \sim 0.61\text{m}$, $\varnothing_{\text{innerILD1}} \sim 0.75\text{m}$
 $L_{\text{outer}} \sim 4.7\text{m}$, tracking volume $\sim 40 \text{ m}^3$
- Weight $\sim 4 \text{ t}$
- Support from Ecal, not from coil
as in Aleph...

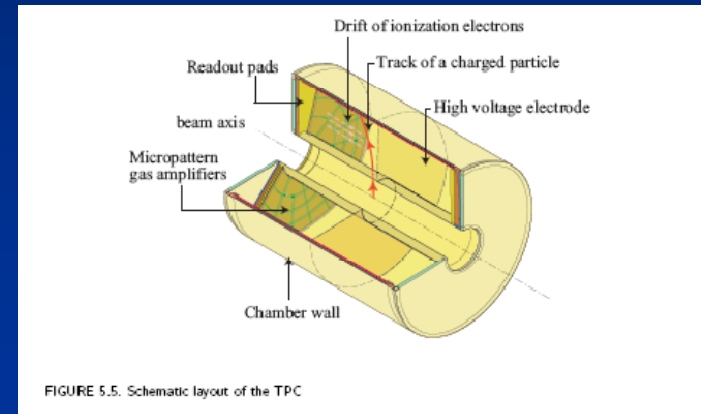
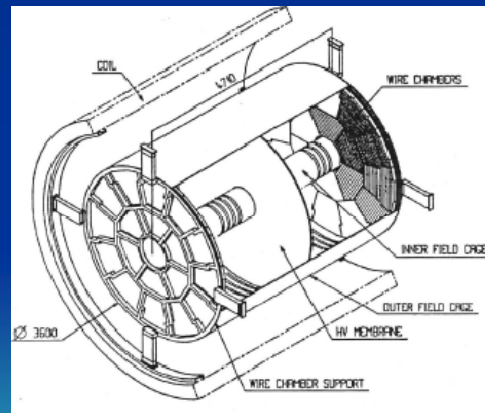

...MDI designing LCTPC support

4. LCTPC engineering model for LOI

- Size, weight, support, dead areas (cont'd)

- Dead areas:

- 10 cm in z at each endcap for "standard" electronics/cables (may be increased later)

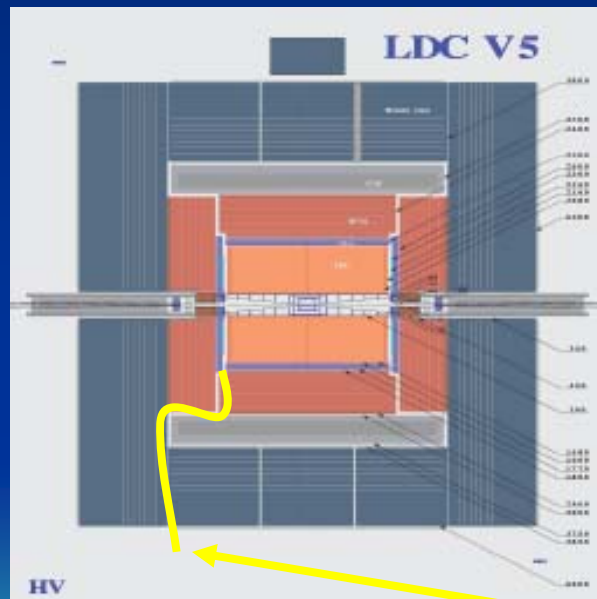

- Space needed for cables here
~10³ cables/side thru 5cm rings ~ 1 m²/side

2) Endplate thickness:

Proposal 2) on Endplate thickness:

=>X_(tpcendplate)/X_0 = 0.15

New Mokka list (** mark changes wrt old list):

dz (mm)	material	% X ₀
0.003	copper	0.02 gating
0.03	kapton	0.01
0.003	copper	0.02
1.964	TPC_gas	0.002
0.003	copper	0.02 mpgd
0.03	kapton	0.01
0.003	copper	0.02
1.964	TPC_gas	0.002
0.003	copper	0.02 mpgd
0.03	kapton	0.01
0.003	copper	0.02
3.964	TPC_gas	0.004
0.05	copper	0.35 pads
2	g10	1.03
0.5	silicon_2.33g/cm	0.53 ROelectr
2	epoxy,etc	1.932
1	kapton	0.35
**2	aluminium	2.24 cooling
1	kapton	0.35
**3	carbonfibre	1.59 stiffness
80.45	Air(0.85)+G10(0.15)	0.02 air+
		+6.22 g10 space:ROboards
summa (new model)		
100mm		14.77 %X ₀

4. LCTPC engineering model for LOI and simulation

- Endplate, electronics, power
- This is about “standard” electronics (CMOS pixel-electronics require a separate study).
- Endplate material-estimate on preceeding slide.
- “Advanced endplate” meetings ongoing to understand the electronic density that will allow building a coolable, stiff, thin endplate.
- The present exercise assumes $\sim 10^6$ channels per endcap.
- With 0.5mW/channel with power pulsing, estimated by a EUDET development of a generalize TPC RO chip based on a further development of the Alice Pasa/Altro \Rightarrow 0.5kW/endcap
- Cooling (liquid or gas) still has to be studied. (Aleph had 1.5kW/endcap cooled with a combination of liquid and gas.)

4. LCTPC engineering model for LOI and simulation

- Fieldcage, chamber gas
- Based on experience (Aleph, Star, Alice) and recent fieldcage for the LP:



we estimate $\sim 3-4\% X_0$ total for the inner and outer fieldcages.

- Gas properties have been rather well understood by our many small-prototype R&D tests. The choice for the LCTPC will be a BIG issue which would require a long discussion for which there is no time here. This has no effect on the simulation. For the engineering, the boundary condition is that we must use a non-flammable gas.

5. Push-pull ability

- At start, guess need 1/pb Z-peak calibration after each push-pull.
- This can probably be relaxed as experience is gained.
- Preliminary hardware discussion at IRENG07, SLAC Sept. 07:

Services Detector ↔ Trailer

TPC :

- 500 W per end plate
- HV/service/data cables: $\sim 10^3$ per side
- Gas/cooling supply
- Alignment laser
- 50-200kW racks in the counting house (trailer)

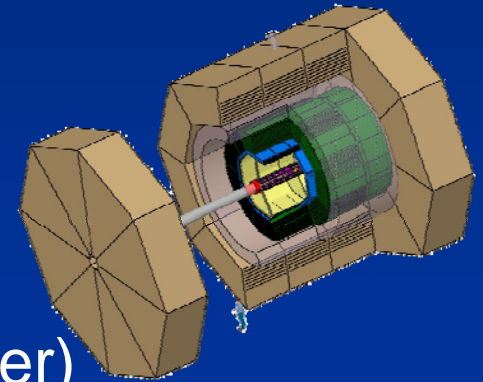

6. \sqrt{s} coverage

- Present optimization studies should confirm a good ILD performance up to 1 TeV.
- The highest possible momentum of a single particle is 0.5 TeV/c which will be measured to $dp/p \sim 1.5\%$ by combined tracking and $\sim 5\%$ by the TPC alone.
- The peak of the momentum distribution of all produced particles (zero to a few 10s of GeV) remains unchanged as \sqrt{s} increases while the tail to high momenta grows. Therefore the vast majority of the particles, the ILD tracking performance will be more than adequate as the c.m.s. energy goes up to and beyond 1 TeV.
- Since the multi-jet numbers grows with logarithmically with \sqrt{s} , the average jet energy increases slowly. For, say, 10-jet production at 1 TeV, the jets will have ~ 0.1 TeV on average, and our PFA resolution is still very good at 0.1 TeV jet energy. \therefore PFA should also be good up to 1 TeV. Of course real life is more complicated, so simulations are needed at 1 TeV.

7. Final comment

- Present optimization studies are showing minor differences in the physics performance of GLD' and LDC', therefore why not simply choose one or the other?
- Also this means that the hardware baseline we choose for the LOI doesn't have to agree exactly with the ones generated for the simulation of LDC' or GLD'.