

Plug compatibility

ALCPG09/GDE cavity integration session

H. Hayano

(1) Specifications table for plug-compatibility

(2) Definitions of boundary

(1) Specification Profile Tables

The purpose of table:

- to understand specification of function, specification of physical dimensions.
- to understand what is fixed, what is not fixed, for item by item.
- to facilitate 'Plug compatibility' concept.

Tables visualize the specifications for;
Cavity
Tuner
Coupler

We had the discussion

- at Cavity Kick-off meeting in DESY (Sep. 2007),
- at ML-SCRF meeting in DESY (Jan. 2008),
- at GDE meeting in Sendai (Mar. 2008),
- at ML-SCRF meeting in FNAL (Apr. 2008)
- at GDE meeting in Chicago (Nov.2008)
- at TILC09 GDE meeting in Tsukuba (Apr. 2009)

No progress afterward -> go to next step

PM already developed "plug-compatibility memo" last year. ->need to complete.

Current tables are followings;

cavity	specification item	specification	unit and comments	further comments
RF properties	Frequency	1.30	GHz	
	Number of cells	9.00	cells	
	Gradient	31.50	MV/m	operational
		35.00	MV/m	Vertical test
	Q0	0.80	10¹⁰	at 35
		1.00	10¹⁰	at 31.5
	HOM damping		Q	decide later
			R/Q	decide later
Short range wake			decide later	
Operating temperature	2.00	K		
Physical properties	Length	1247	mm	TESLA-short length
	Aperture		mm	must be compatible with beam dynamics
	Alignment accuray	300.00	um	rms
	Material	Niobium		
	Wall thickness	2.80	mm	
	Stiffness			decide later
	Flange/Seal system		Material	decide later
	Maximum overpressure allowed		2bar	
	Lorentz force detuning over Flat-top at 35 MV/m	1.00	kHz	maximum
	Outer diameter He vessel	230.00	mm(inner diameter)	Mag shield outside, decide later for precise number
		230.00	mm(inner diameter)	KEK Mag shield inside, decide later for precise number
	Magnetic shielding		inside/outside	decide later

* yellow boxes indicate 'not fixed'

tuner	specification item	specification	unit and comments	further comments
Slow tuner	Tuning range	>600	kHz	
	Hysteresis in Slow tuning	<10	µm	
	Motor requirement	step-motor use, Power-off Holding, magnetic shielding		
	Motor specification	ex) 5 phase, xxA/phase, ...	match to driver unit, match to connector pin assignment,...	decide later
	Motor location	inside 4K? / outside 300K? / inside 300K accessible from outside?	need availability discussion, MTBF	decide later
	Magnetic shielding	<20	mG at Cavity surface, average on equator	
	Heat Load by motor	<50	mW at 2K	
	Physical envelope	do not conflict with GRP, 2-phase line, vessel support, alignment references, Invar rod, flange connection,...		cable connection, Mag shield
	Survive Frequency Change in Lifetime of machine	~20 Mio. steps	could be total number of steps in 20 years,	

* yellow boxes indicate 'not fixed'

Fast tuner	Tuning range	>1	kHz over flat-top at 2K	
	Lorentz detuning residuals	<50	Hz at 31.5MV/m flat-top	(LD and microphnics? or LD only?) :decide later
	Actuator specification	ex) low voltage piezo 0-1000V, ...	match to driver unit, match to connector pin asignment, ...	decide later
	Actuator location	insdie 4K?/inside 4K accessible/inside 100K? accesible / inside 300K accessible from outside?		decide later
	Magnetic shielding	<20	mG at Cavity surface average	
	Heat Load in operation	<50	mW	
	Physical envelope	do not conflict with GRP, 2-phase line, vessel support, alignment references, Invar rod, flange connection,...		
	Survive Frequency Change in Lifetime of machine	>10 ¹⁰	number of pulses over 20 years, (2x10⁹:operational number)	

* yellow boxes indicate 'not fixed'

Coupler	condition	specification	unit and comments	further comments
Power requirements	Operation	>400	kW for 1600 us	
	Processing	>1200	kW upto 400 us	need after vac break, cool-down
		>600	kW larger than 400 us	need after vac break, cool-down
	Processing with reflection mode	>600	kW for 1600us	in Test stand
Processing time	warm	<50	hours	after installation, definition of power/pulse_width target are the same as 'Power Requirement' above.
	cold	<30	hours	after installation, definition of power/pulse_width target are the same as 'Power Requirement' above.
Heat loads /coupler	2K static	< 0.063	W	
	5K static	< 0.171	W	depend on tunability
	40 K static	< 1.79	W	
	2K dynamic	< 0.018	W	
	5K dynamic	< 0.152	W	
	40K dynamic	< 6.93	W	
Cavity vacuum integrity	# of windows	2		
	bias capability	yes		
RF Properties	Qext		tunable	
	Tuning range	1-10	10 ⁶ if tunable	
Physical envelope	Position		compatible to TTF-III	decide later
	Flange		compatible to TTF-III	decide later (to cavity, to cryostat)
	waveguide		compatible to TTF-III	decide later
	support		compatible to TTF-III	decide later
Instrumentation	vacuum level	>= 1		
	spark detection		0at window	
	electron current detection	>= 1	at coax	
	temperature	>= 1	at window	

* yellow boxes indicate 'not fixed'

Plug compatible conditions at Cavity package (proposal)

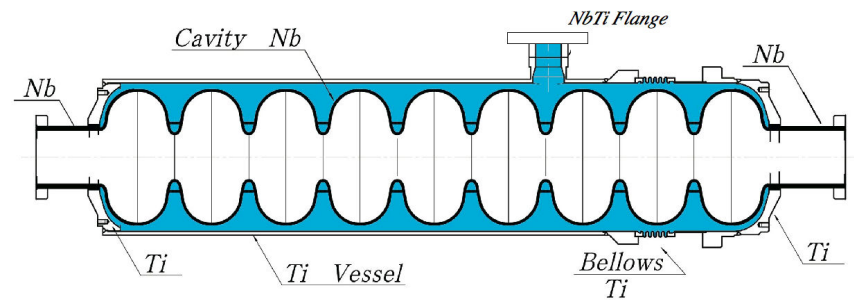
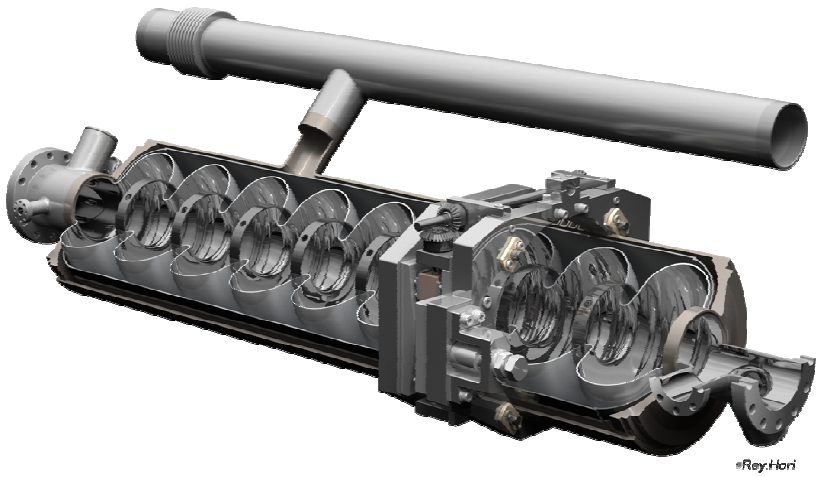

Item	Can be flexible	Plug-compatible
Cavity shape	TESLA /LL /RE	
Length		Required
Beam pipe dia		Required
Flange		Required
Tuner	blade/slide-jack	
Coupler flange		Required
He-in-line joint		Required

Cavity boundary

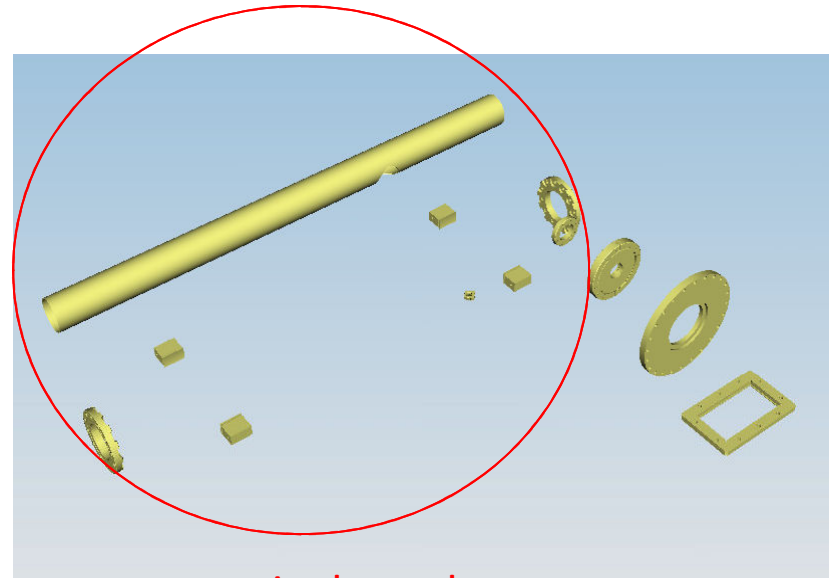
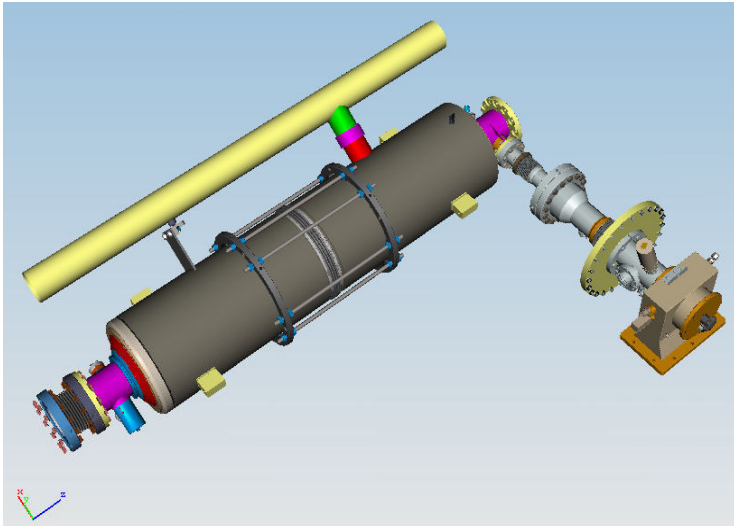

cavity boundary

- (1) beam pipe port flange
- (2) coupler port flange
- (3) 4 support tabs
- (4) He pipes

Input coupler boundary

BCD: TTF3 coupler

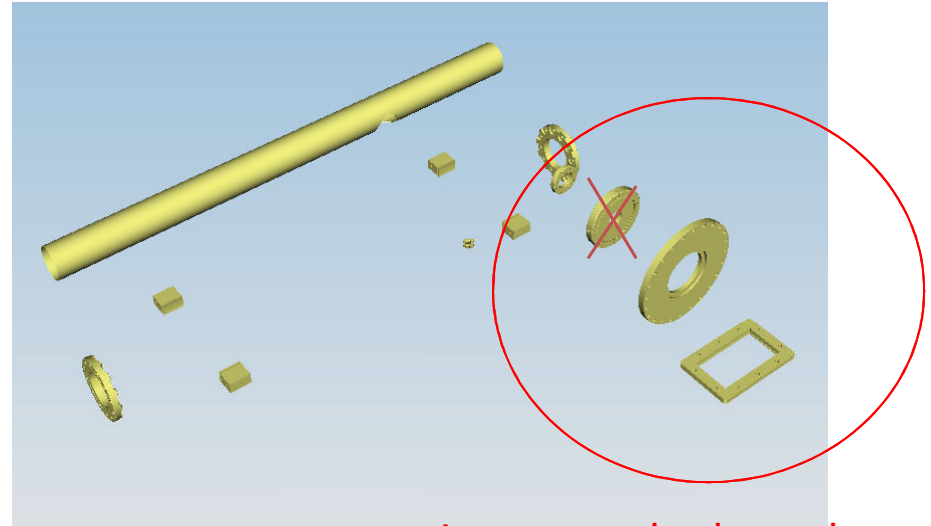
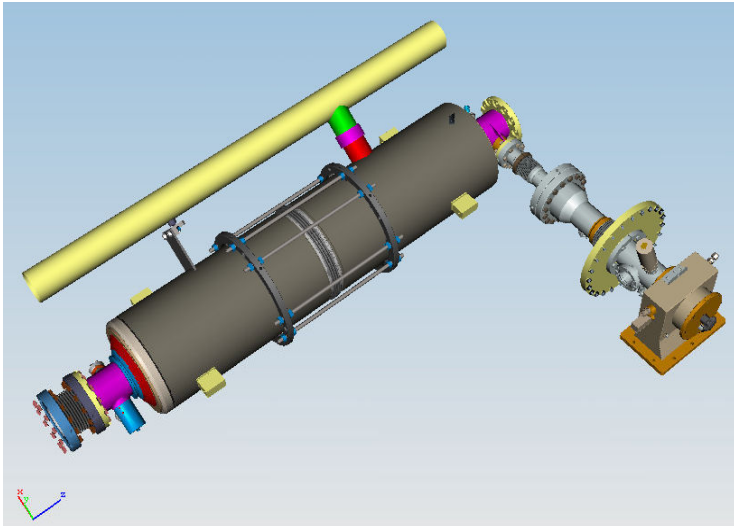

input coupler boundary

- (1) cavity port flange
- (2) cryostat vessel flange
- (3) waveguide flange

Next Plan for plug-compatibility

- **Complete document anyway**
plug-compatibility level,
component specification,
boundary definition,
guide-line
drawings, etc.
- **circulate document**