

# Cavity Resonance Control

LLRF Lecture Part4

S. Simrock, Z. Geng

DESY, Hamburg, Germany

A horizontal dotted line in a light yellow-green color is located at the bottom of the slide, mirroring the one at the top.

- Motor tuner (slow), used to
  - Large range frequency tuning, such as by-pass ( $\Delta\omega > 10$  times of bandwidth) the cavity or set the pre-detuning
  - Can not be tuned frequently because the motor lifetime
- Piezo tuner (fast), used to
  - Fine tuning of the cavity
  - Lorenz force detuning or microphonics compensation

# Motor Tuner

The **Motor tuner** is used to tune the cavity resonance frequency by deforming the whole cavity along the axis. It uses a stepper motor and is considered as a slow control (compared with the piezo tuner).

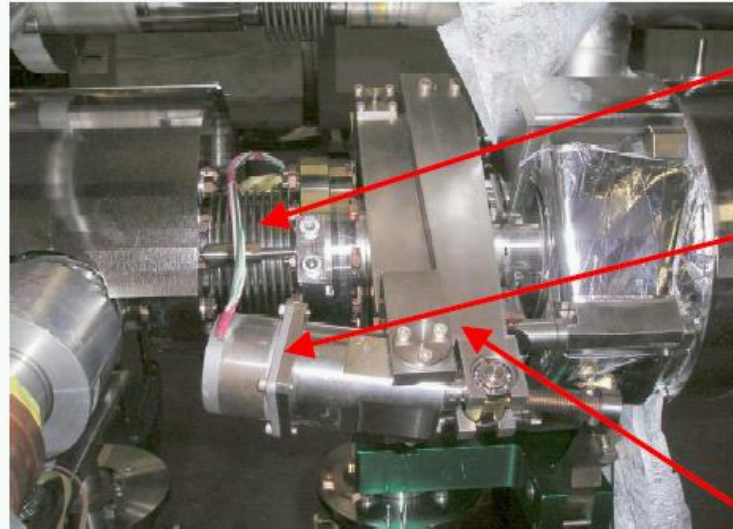

bellow connection  
between nearest cavities

stepper motor

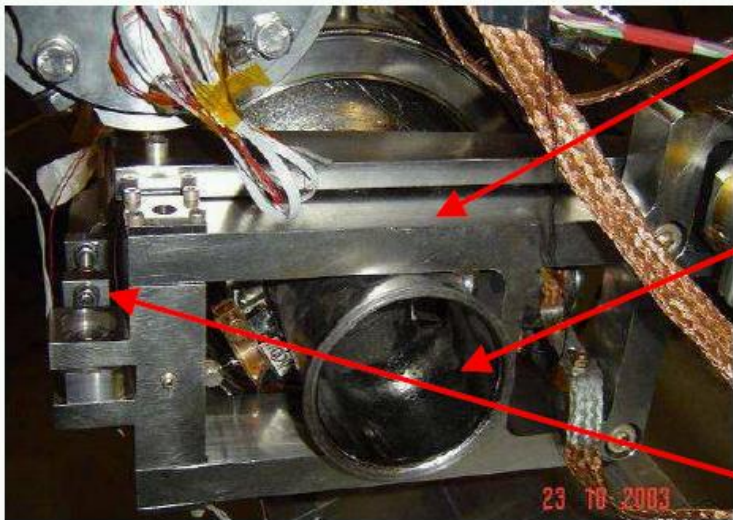

double lever mechanism

cavity flange

piezostack fixture

# Piezo Tuner

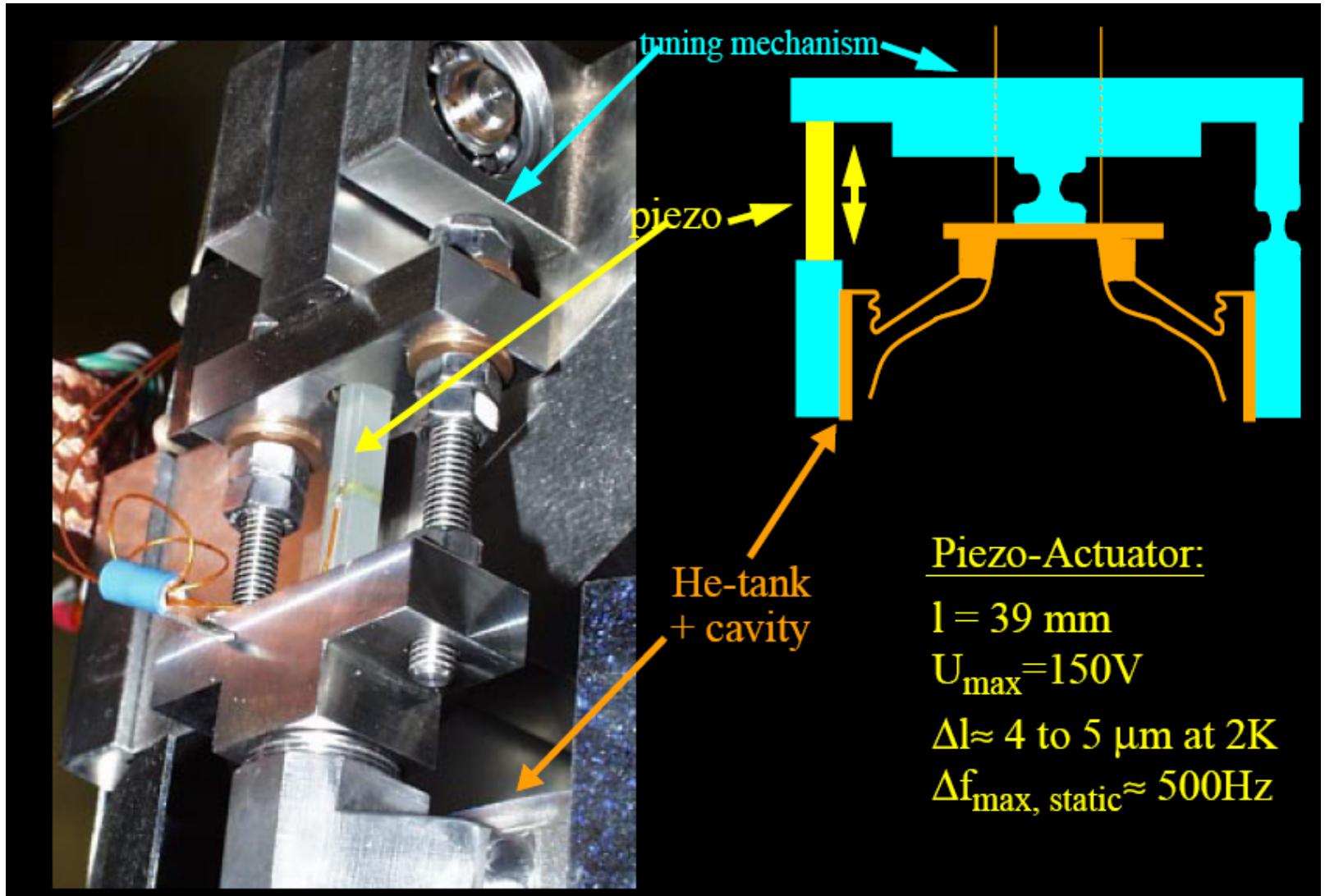

- Lorenz force detuning control
  - Feed forward control is suitable
    - Coupling of Lorenz force and piezo actuator to cavity detuning must be similar
    - Slow parameter changes can be corrected with adaptive feed forward
- Microphonics control
  - Feedback control
    - Transfer function from piezo actuator to detuning must allow controller design which allows stability of closed loop
    - Transfer function must be stable for timescale of adaptation of controller
  - Adaptive feed forward control
    - Noise cancellation with adaptive filters

# Recall the Lorenz Force Detuning Model

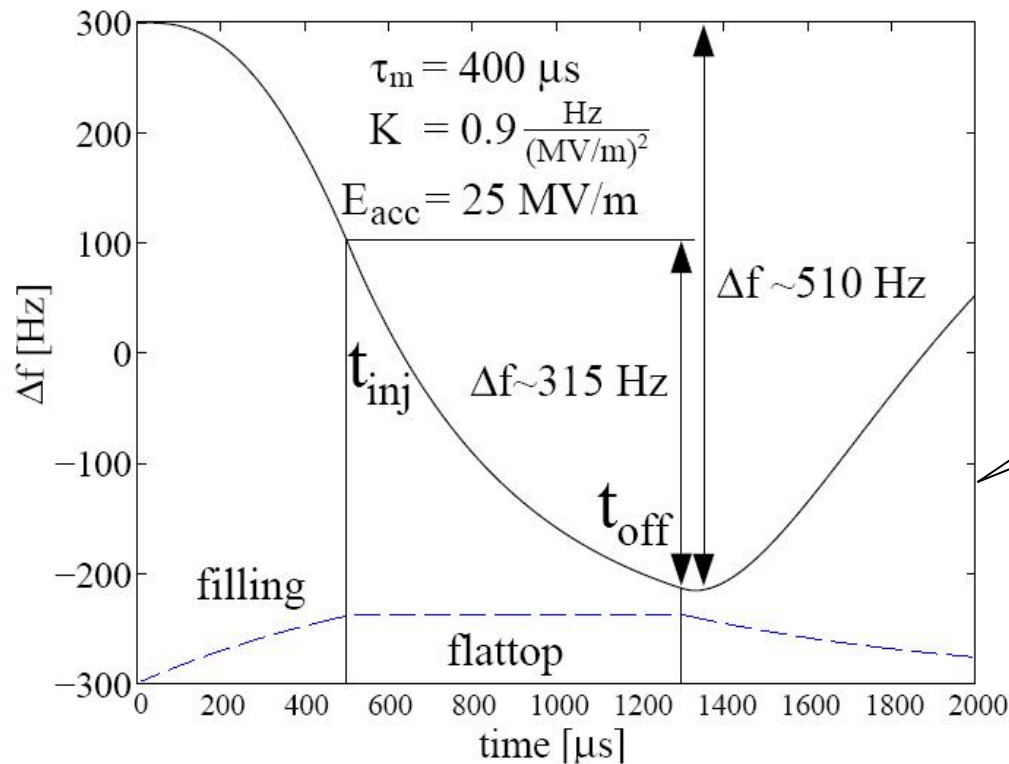

Repetitive from pulse to pulse with same gradient.



# Transfer Function Lorentz Force - Detuning

Transfer function Lorentz Force --> Detuning, SNS cavity

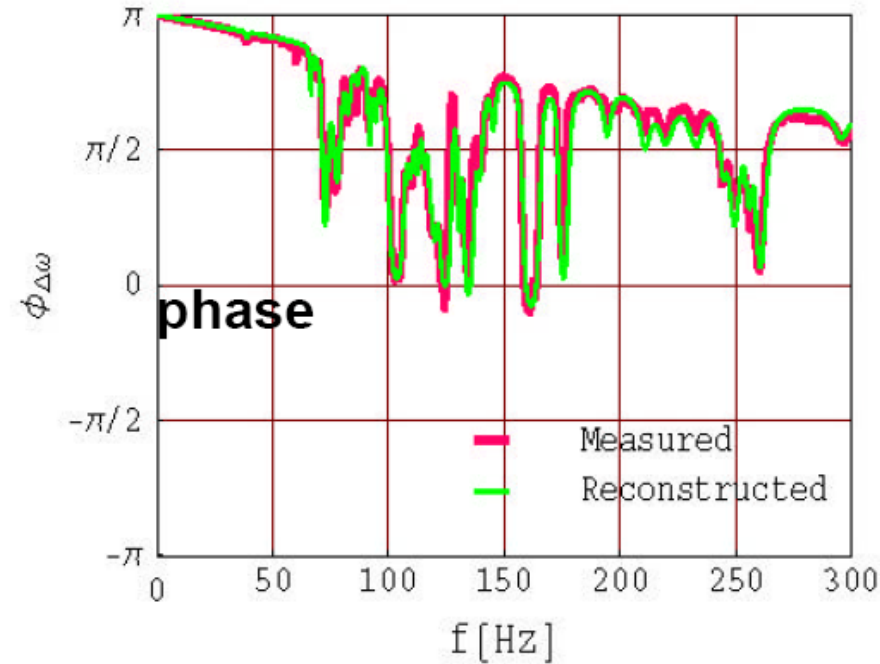
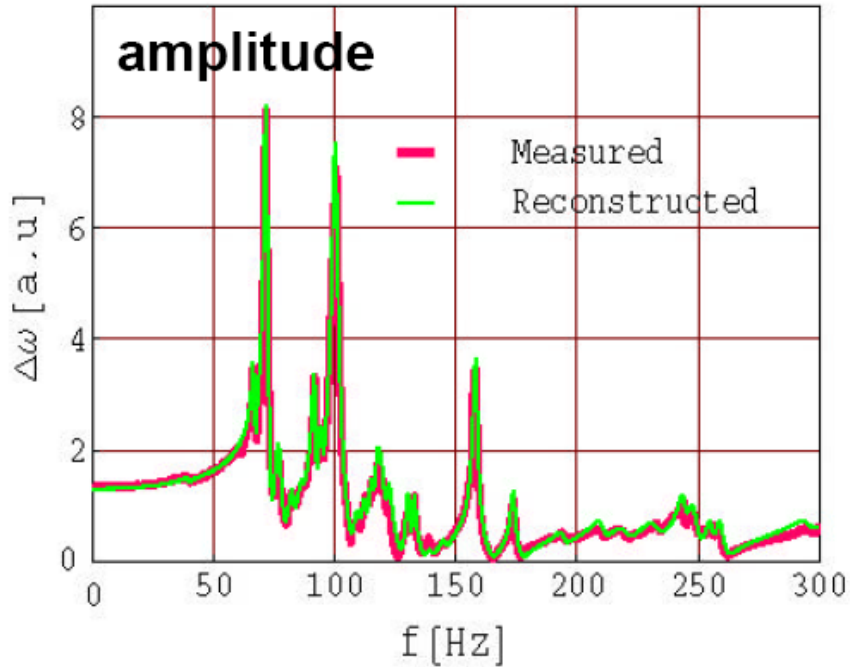

courtesy: J. Delayen, JLAB, M. Doleans, ORNL



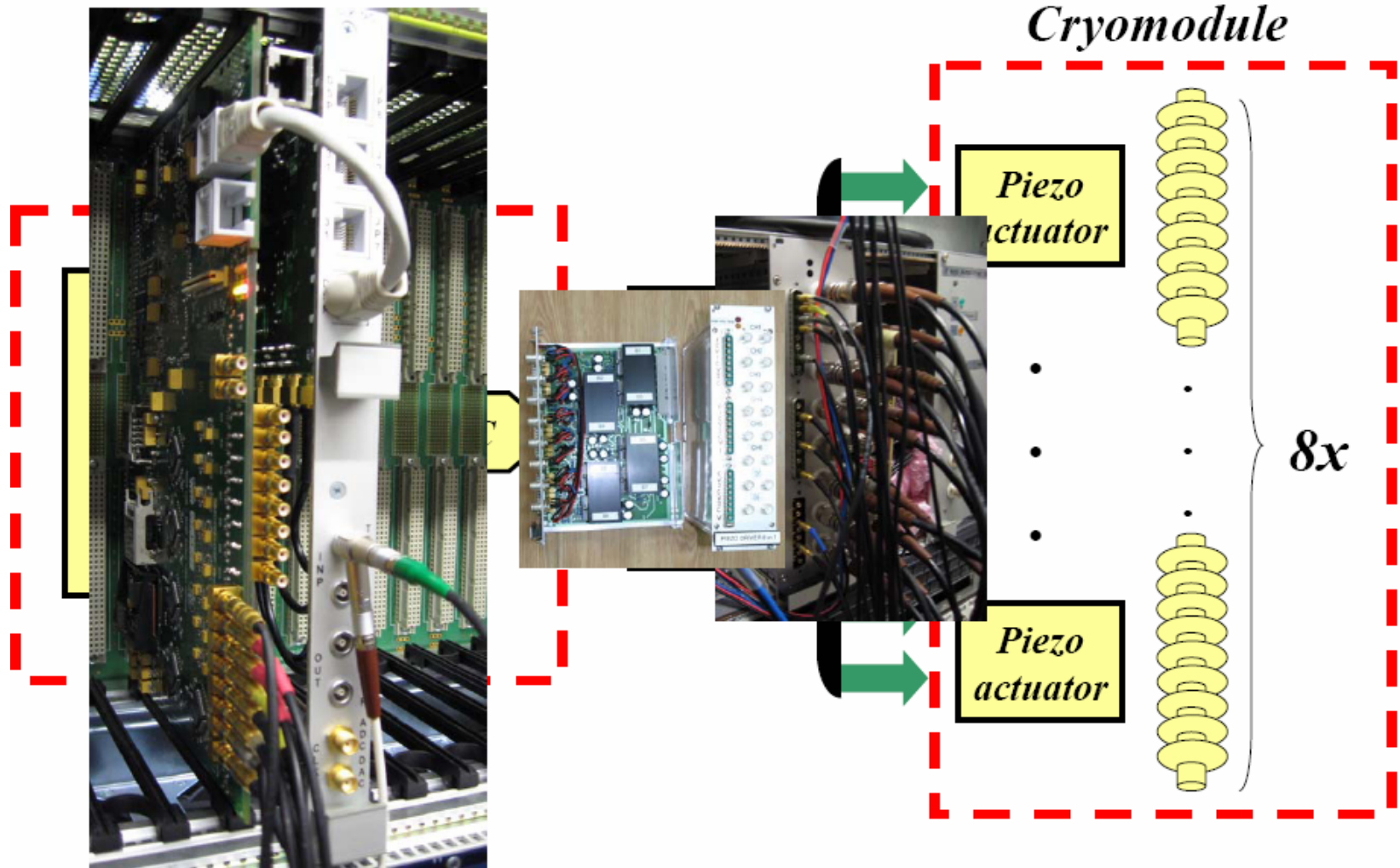





# Active Compensation of Lorentz Force Detuning with Feed Forward Control

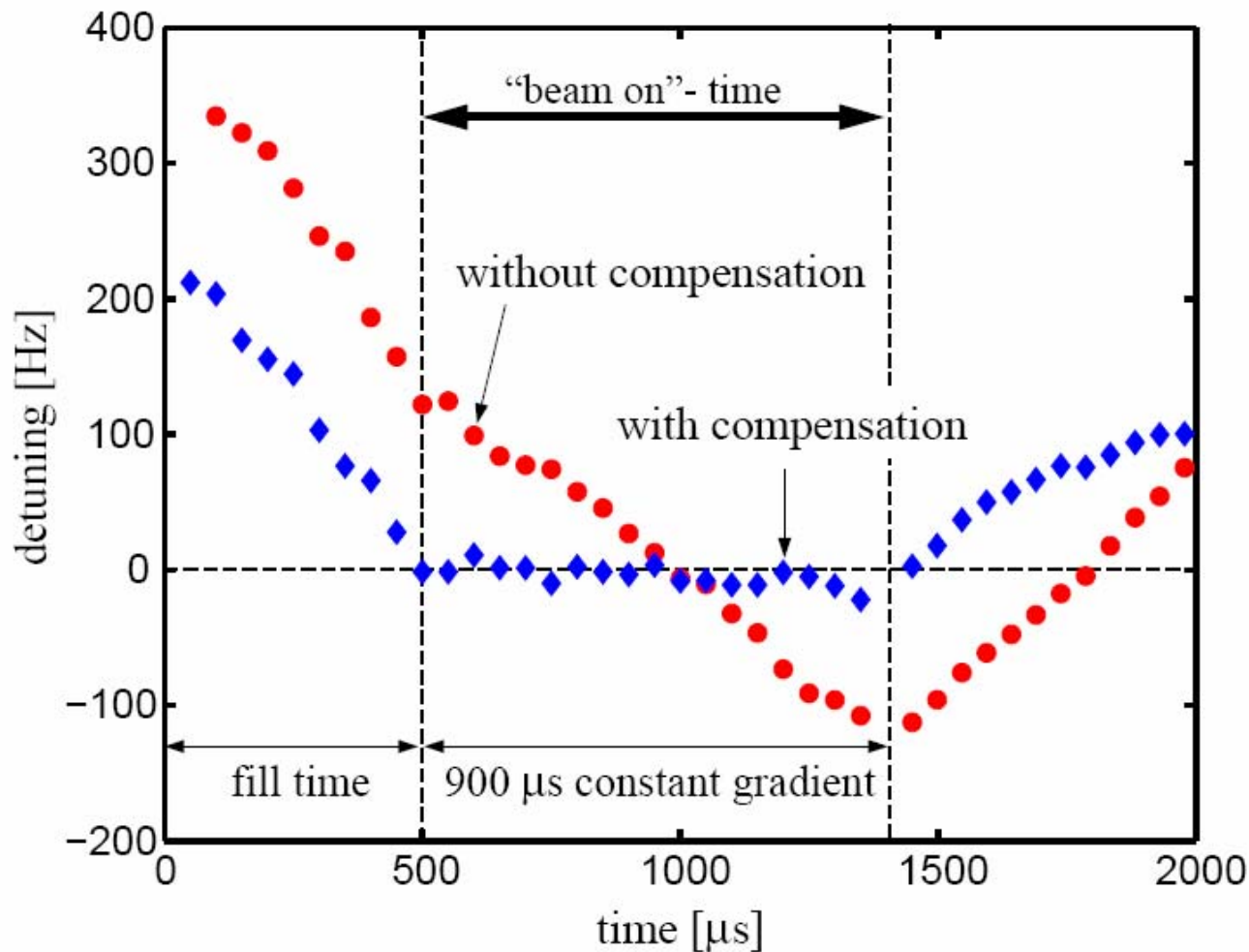

**9-cell cavity  
operated at  
23.5 MV/m**

**Lorentz force  
compensated  
with fast  
piezoelectric  
tuner**



# More Results at ACC6 of FLASH

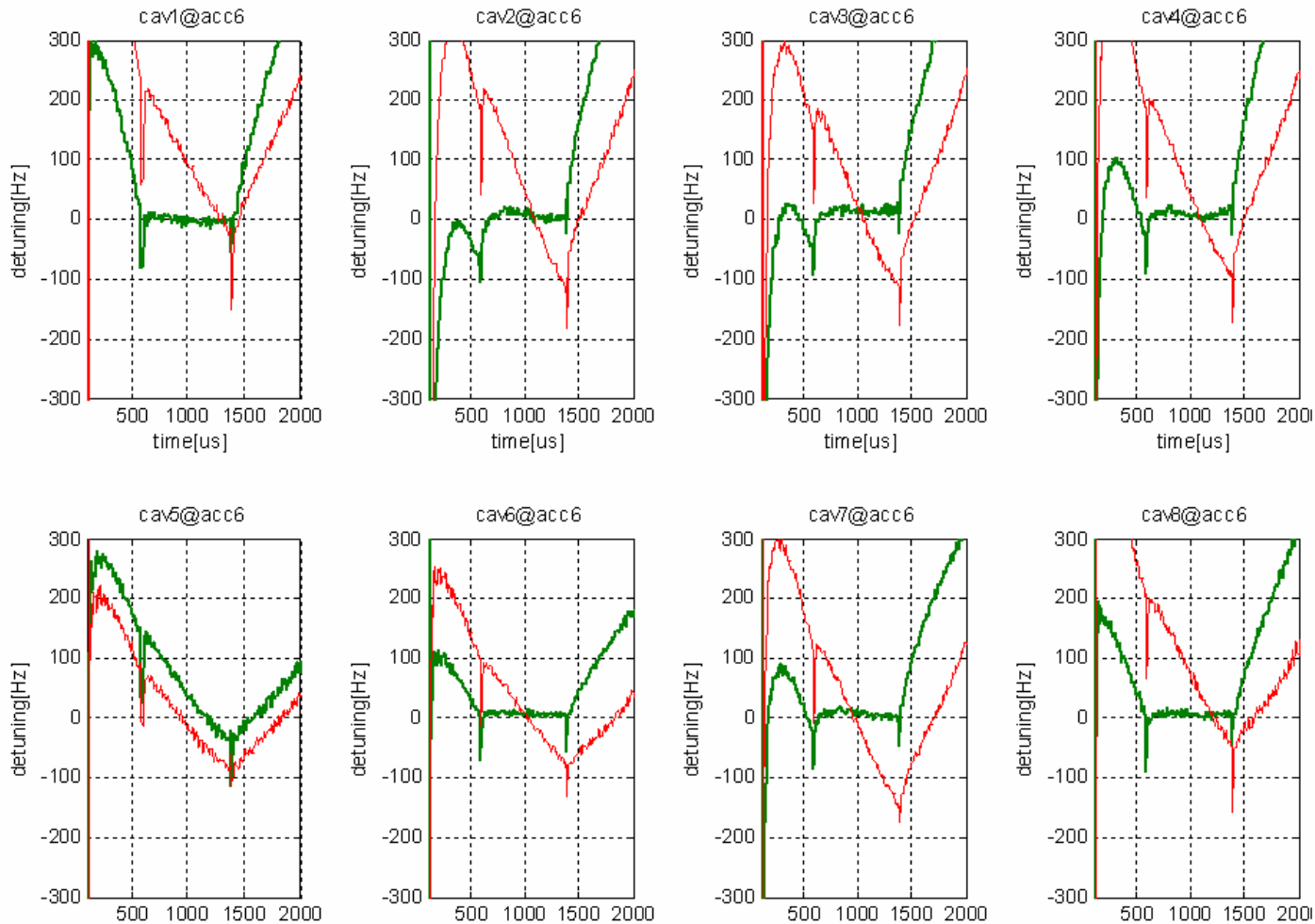

**Problem with tuner assembling**

# Concept for Controlling Microphonics with Feedback

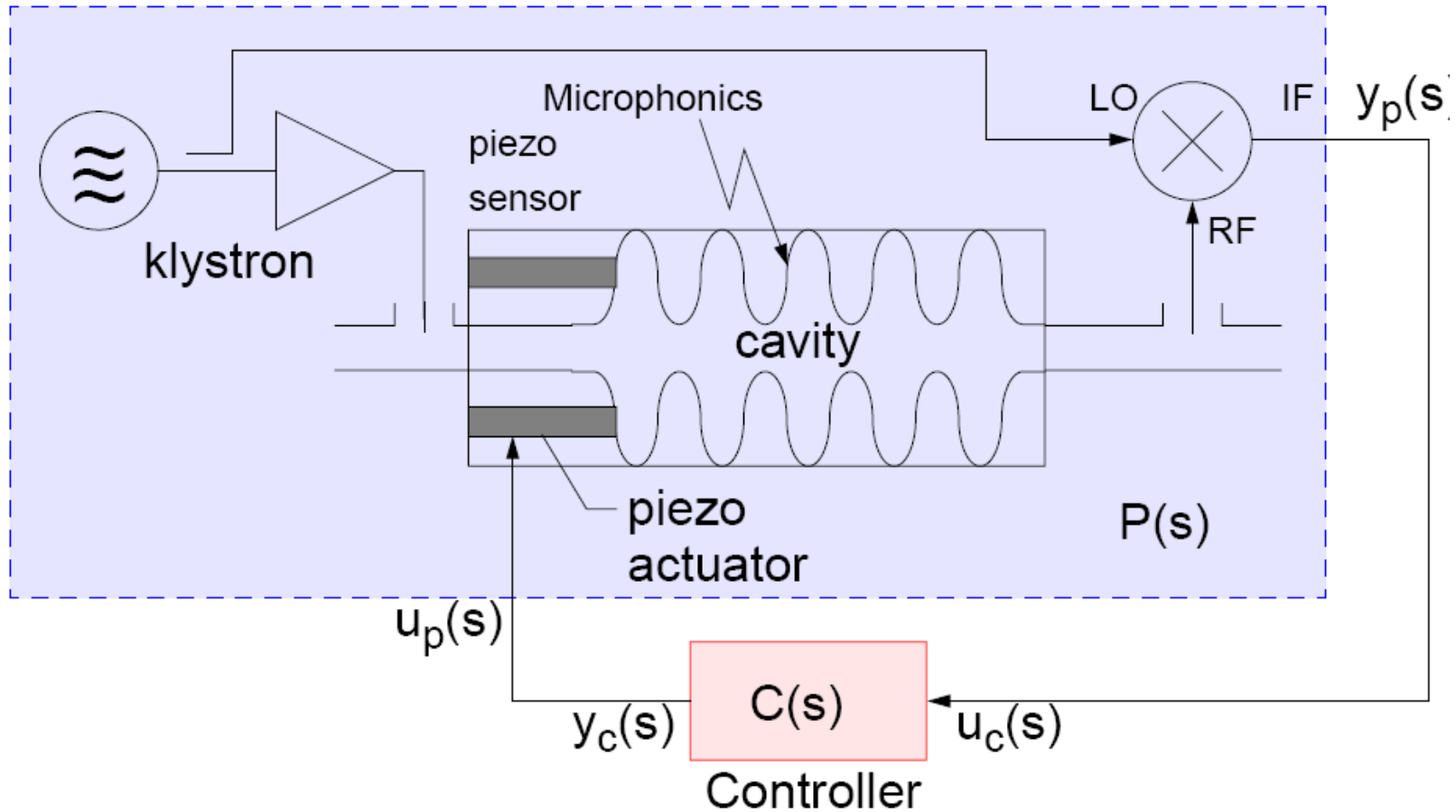

# Microphonics Control of a Quarter Wave Cavity

- Feedback is stable up to several hundred Hz, because the vibrations from the microphonics have a low frequency, while the resonance peaks in the piezo tuner transfer function locate at higher frequency

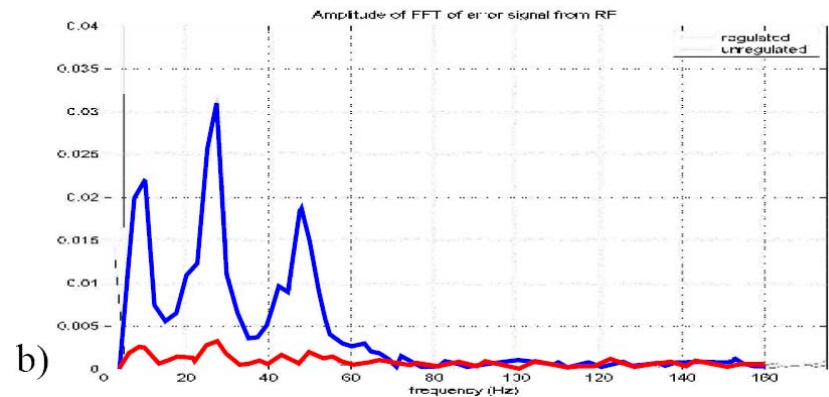
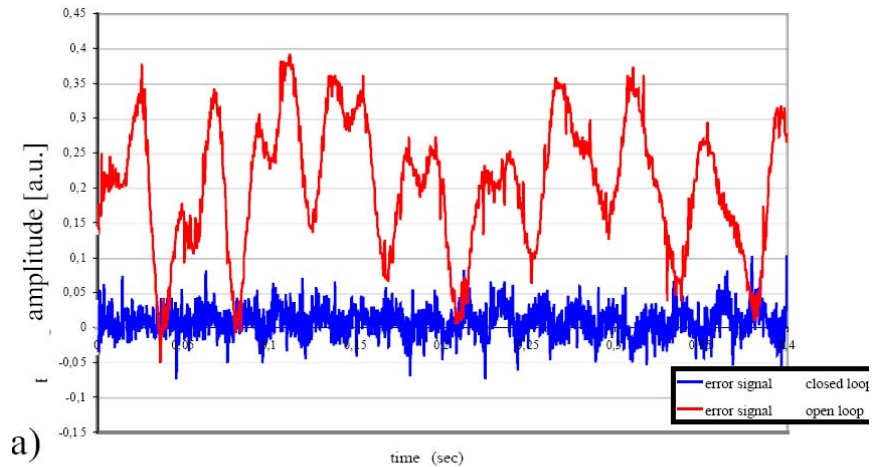

Active suppression of microphonic noise with feedback applied to fast piezo tuner. a) Time domain measurement. b) Frequency domain measurement

## Transfer function Piezo Tuner --> Detuning, SNS cavity

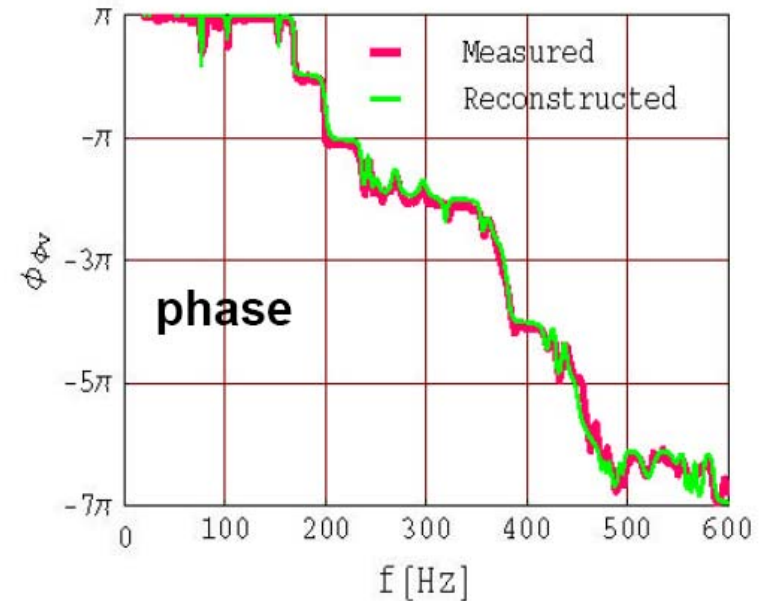
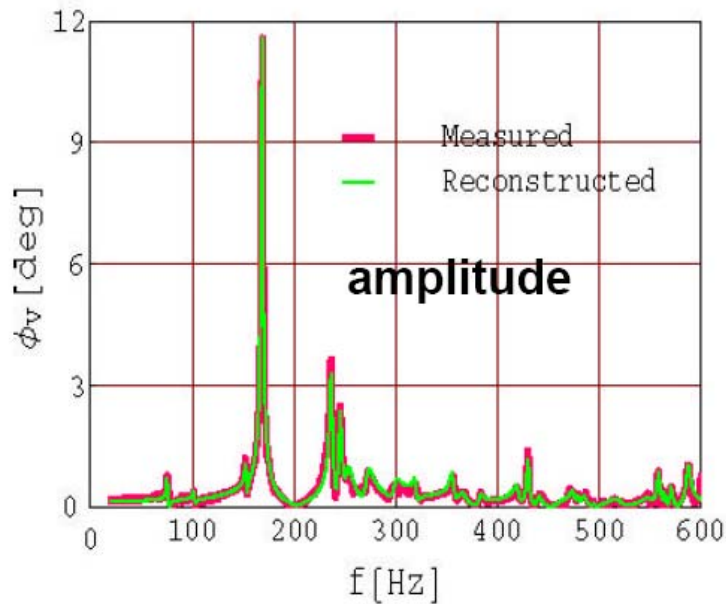

courtesy: J. Delayen, JLAB, M. Doleans, ORNL



- For multi-cell cavities like SNS cavity and TESLA cavity, feedback system for microphonics control is unstable because the many resonance peaks at low frequency which dramatically decrease the gain margin!

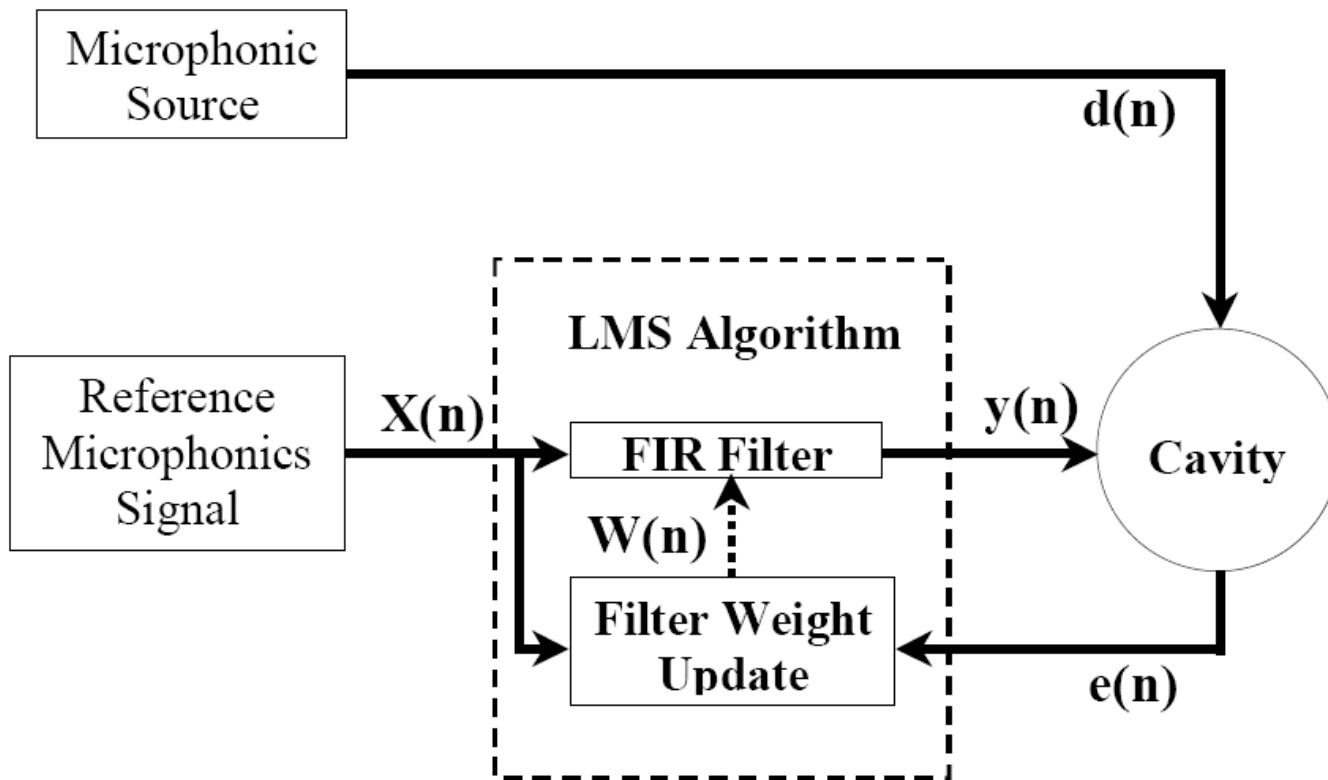

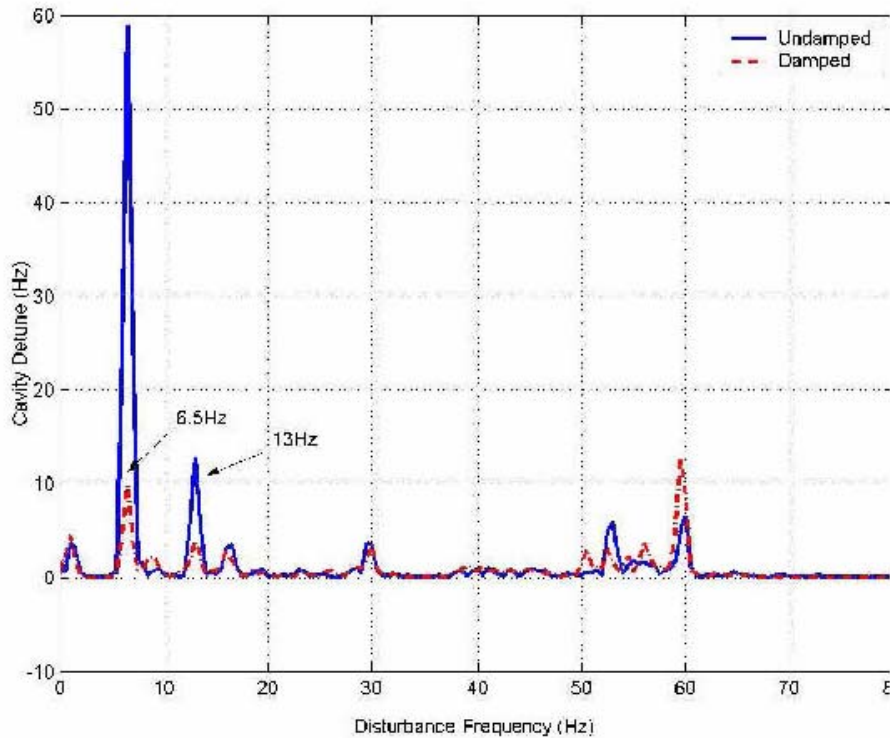

Active damping of helium oscillations at 2K.

**T. Grimm**

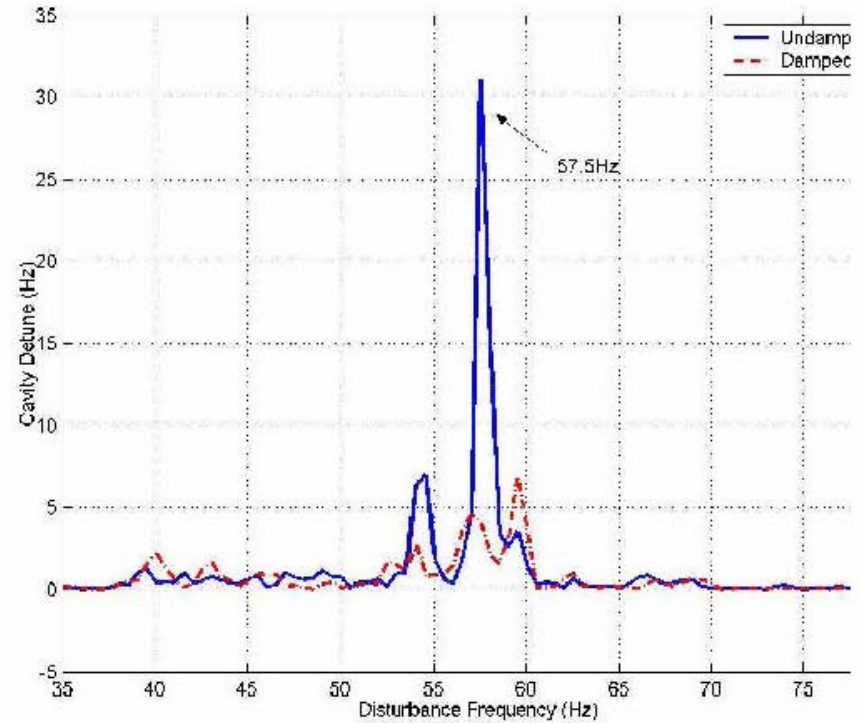

Active damping of external vibration at 2K.



# Piezo Control of Microphonics with Adaptive Feed Forward in Fermilab

FNAL, 3-cell 3.9 GHz

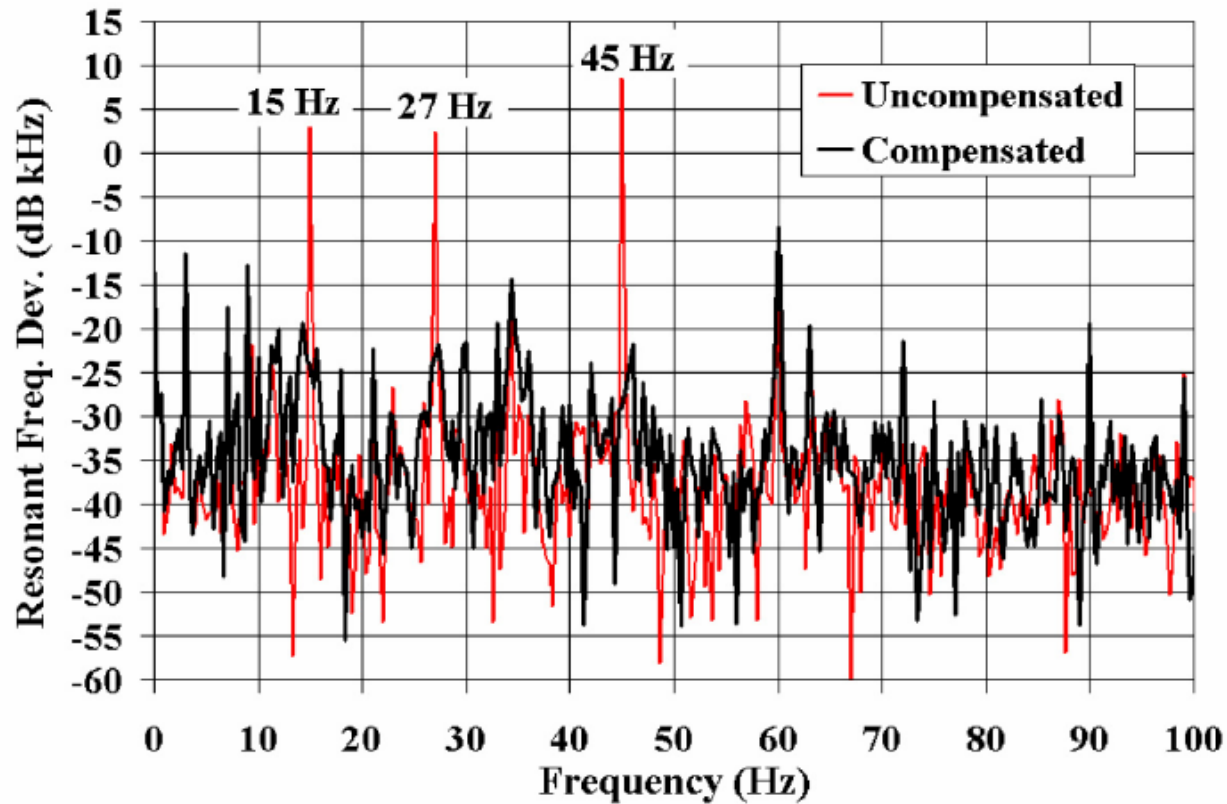



In this part, we have learnt:

- Motor tuner and piezo tuner can be used to control the cavity resonance frequency
- Lorenz force detuning can be controlled with (adaptive) feed forward control
- Feedback can be used to control the microphonics for some special cavities, but does not work well for multi-cell cavities like the SNS or TESLA cavity
- Adaptive noise cancellation can be used to control the microphonics

- [1] P. Sekalski, S. Simrock, et.al. Lorenz Force Detuning Compensation System for Accelerating Field Gradient Up to 35 MV/m for Superconducting XFEL and TESLA Nine-Cell Cavities. CARE-Conf-04-001-SRF
- [2] S. Simrock, G. Petrosyan, et.al. First Demonstration of Microphonic Control of A Superconducting Cavity with A Fast Piezoelectric Tuner. PAC2003
- [3] R. Carcagno, L. Bellantoni, et.al. Microphonics Detuning Compensation in 3.9 GHz Superconducting RF Cavities. SRF2003