



High Power RF

S. Simrock, S. Choroba
DESY, Hamburg, Germany



Overview

- Introduction High Power RF System
- Klystron
- Modulator
- RF Waveguide Distribution



Introduction High Power RF System

- Task:
Conversion of AC Line Power to Pulsed RF Power and distribution of the Pulsed RF Power to the cavities of the Linear Collider
- Structure:
Several RF Station consisting of certain components make up the RF System of a linear collider (total RF pulse power:~1-10GW)
The number of station depends on the maximum power which can be handled reliably by one station (and of course on availability of components, costs etc)
- Pulse Power per Station: ~100kW to ~1-10MW (ILC) to ~100MW (norm. cond. acc.)
- Pulse Width: (~1 μ s for norm. cond. acc. to) ~1ms (ILC)
- Repetition Rate: ~1Hz to ~10Hz (ILC) ~100Hz(norm. cond. acc.)
- Average power per Station: ~100kW (ILC)



RF Station Components (1)

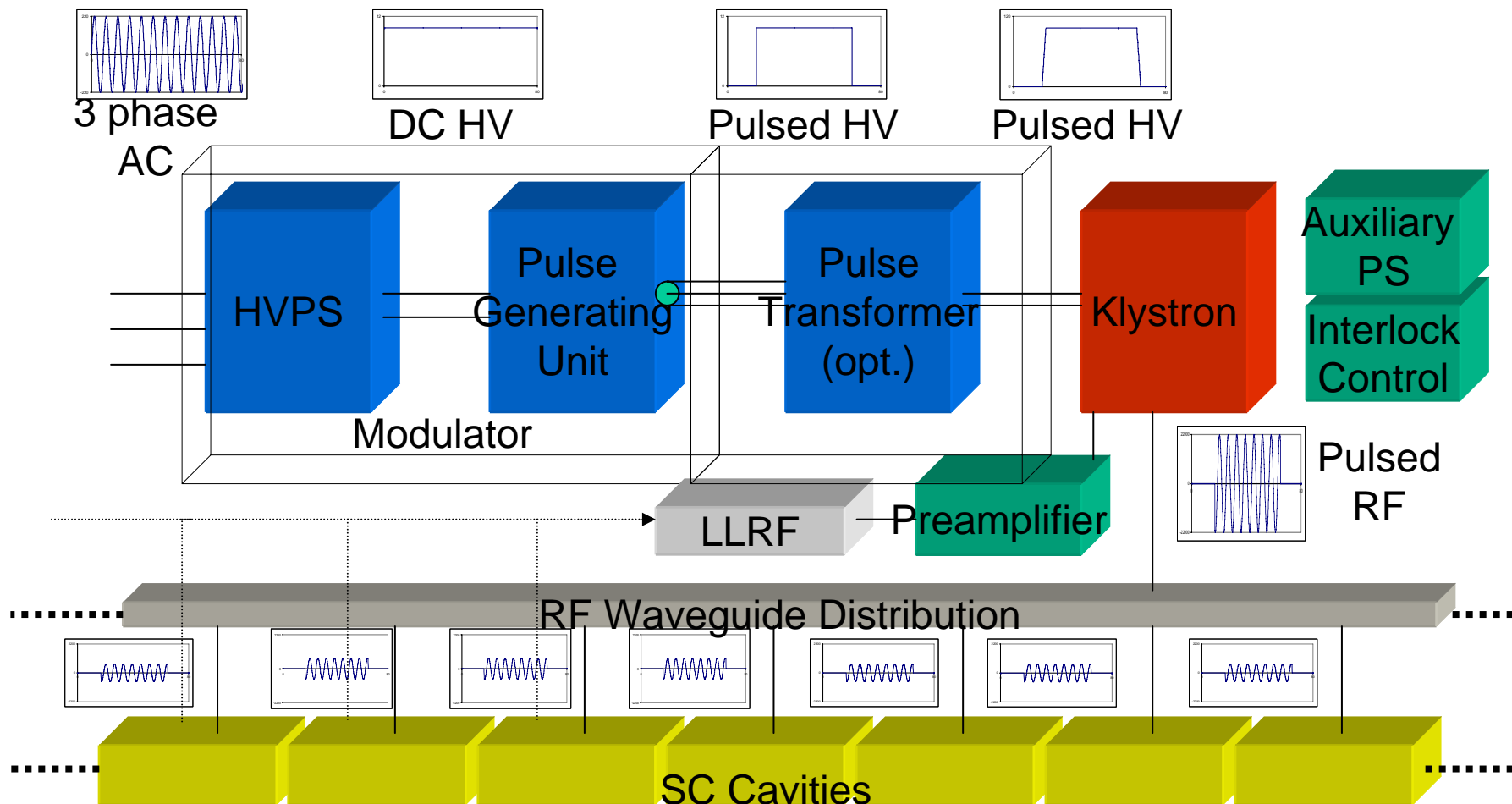



RF Station Components (2)

- Modulator:
 - HVPS: Conversion of AC line voltage ($\sim 400\text{V AC}$) to DC HV ($\sim 1\text{-}10\text{kV}$ (100kV))
 - Pulse Generating Unit: Conversion of DC HV ($\sim 1\text{-}10\text{kV}$ (100kV)) to Pulsed HV ($\sim 1\text{-}10\text{kV}$ (100kV))
 - Pulse Transformer: Transformation of Pulsed HV (typ. $\sim 10\text{kV}$) to higher Pulsed HV ($\sim 100\text{kV}$)
- Klystron:
 - Conversion of Pulsed HV ($\sim 100\text{kV}$) to pulsed RF ($\sim 10\text{MW}$)
- RF Waveguide Distribution:
 - Distribution of RF power ($\sim 10\text{MW}$) to the cavities ($\sim 100\text{kW}$)
- Other
- Auxiliary PS: Certain voltages for the klystron ion pumps or the klystron solenoid
- Interlock and Controls: Protection and Control
- LLRF: Control of phase, shape and amplitude (other lecture this school)
- Preamplifier: Amplification of $\sim 1\text{mW}$ RF to $\sim 100\text{W}$ RF



TESLA 500 RF Requirements

TDR 2001 (ILC Baseline is similar)

Number of sc cavities:	21024 total
Frequency:	1.3GHz (L-Band)
Power per cavity:	231kW
Gradient at 500GeV:	23.4MV/m
Power per 36 cavities (3 cryo modules):	8.3MW
Power per RF station:	9.7MW (including 6% losses in waveguides and circulators and a regulation reserve of 10%)
Number of RF stations:	572
Macro beam pulse duration:	950ms
RF pulse duration:	1.37ms
Repetition rate:	5Hz
Average RF power per station:	66.5kW

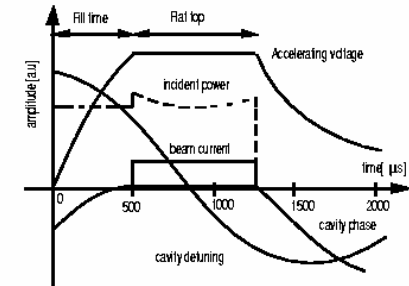

For TESLA 800 the number of stations must be doubled. The gradient is 35MV/m.



RF System Components

developed for Tesla and installed at TTF

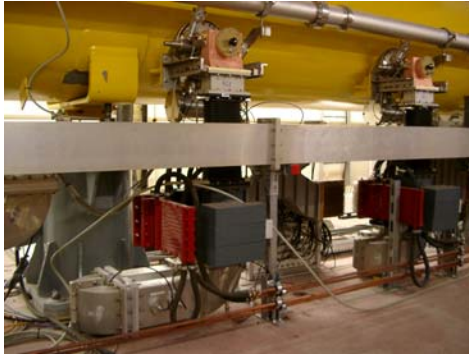

RF Waveguide Distribution



Modulator



Pulse Transformer