

Construction of a Digital Hadron Calorimeter with Resistive Plate Chambers

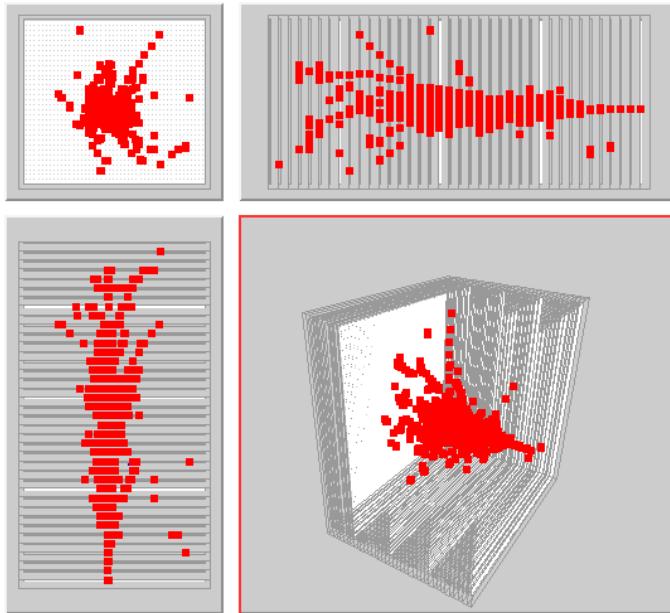

José Repond
Argonne National Laboratory

International Linear Collider Workshop 2010
Institute of High Energy Physics
Beijing, People's Republic of China
March 26 – 31, 2010

RPC DHCAL Collaboration



Argonne

Carol Adams

Mike Anthony

Tim Cundiff

Eddie Davis

Pat De Lurgio

Gary Drake

Kurt Francis

Robert Furst

Vic Guarino

Bill Haberichter

Andrew Kreps

Zeljko Matijas

José Repond

Jim Schlereth

Frank Skrzecz

(Jacob Smith)

(Daniel Trojand)

Dave Underwood

Ken Wood

Lei Xia

Allen Zhao

Boston University

John Butler

Eric Hazen

Shouxiang Wu

Fermilab

Alan Baumbaugh

Lou Dal Monte

Jim Hoff

Scott Holm

Ray Yarema

IHEP Beijing

Qingmin Zhang

University of Iowa

Burak Bilki

Edwin Norbeck

David Northacker

Yasar Onel

McGill University

François Corriveau

Daniel Trojand

UTA

Jacob Smith

Jaehoon Yu



RED = Electronics Contributions
GREEN = Mechanical Contributions
BLUE = Students
BLACK = Physicist

Particle Flow Algorithms

The idea...

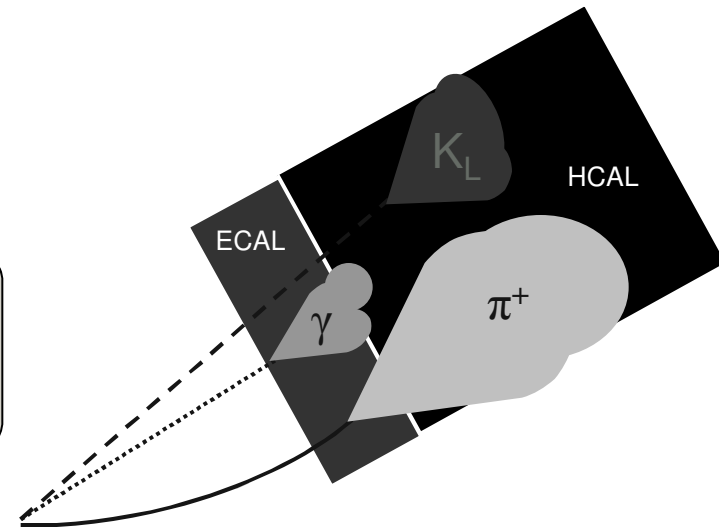
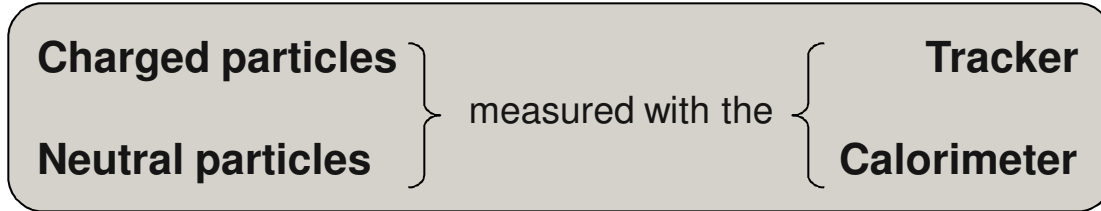

Particles in jets	Fraction of energy	Measured with	Resolution [σ^2]
Charged	65 %	Tracker	Negligible
Photons	25 %	ECAL with $15\%/\sqrt{E}$	$0.07^2 E_{\text{jet}}$
Neutral Hadrons	10 %	ECAL + HCAL with $50\%/\sqrt{E}$	$0.16^2 E_{\text{jet}}$
Confusion		Required for $30\%/\sqrt{E}$	$\leq 0.24^2 E_{\text{jet}}$

} 18%/√E

Requirements for detector system

- Need excellent tracker and high B – field
 - Large R_1 of calorimeter
 - Calorimeter inside coil
 - Calorimeter as dense as possible (short X_0 , λ_1)
 - Calorimeter with **extremely fine segmentation**
- } **thin active medium**
- } **RPC**
- ↳ Counting # of hits sufficient → 'digital readout'

1 m³ – Digital Hadron Calorimeter Physics Prototype

Description

Readout of 1 x 1 cm² pads with one threshold (1-bit) → **Digital Calorimeter**

40 layers each ~ 1 x 1 m²

Each layer with 3 RPCs, each 32 x 96 cm²

~400,000 readout channels

Layers to be inserted into the existing CALICE Analog (scintillator) HCAL structure

Purpose

Validate DHCAL concept

Gain experience running large RPC systems

Measure hadronic showers in great detail

Validate hadronic shower models

Status

Started construction in 2008 - 09



RPC Construction

RPC design

- 2 – glass RPCs
- 1 – glass RPCs (developed at Argonne)
- Gas gap size 1.1mm
- Total RPC thickness < 3.4mm
- Dead area ~5% (frame, fishing lines)

Chambers needed

~114 + spares

Material

- Glass in hand for 300 chambers
- Kilometers worth of PVC frame extruded

Assembly steps

- Spraying of glass plates with resistive paint
- Cutting of frame pieces
- Gluing frame
- Gluing glass plates onto frame
- Mounting of HV connection, etc.

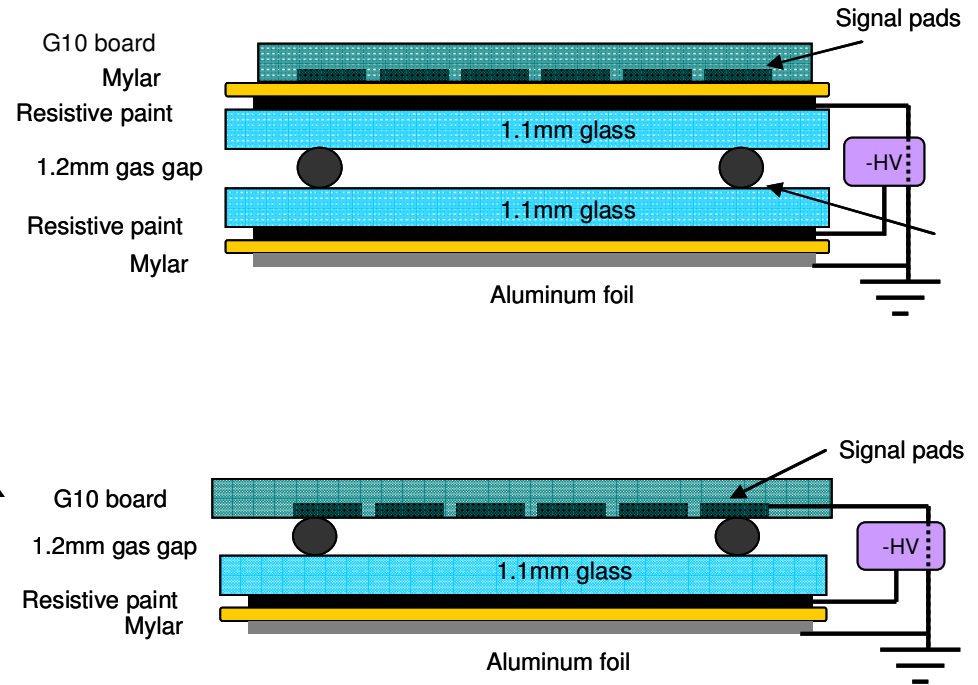

Spraying of the glass sheets

Challenge

Produce a uniform layer with $R_{\square} = 1 - 5 \text{ M}\Omega$

value affects pad multiplicity

value only critical for thin plate, thick plate can be lower/higher

Measurements with 20 x 20 cm² chambers

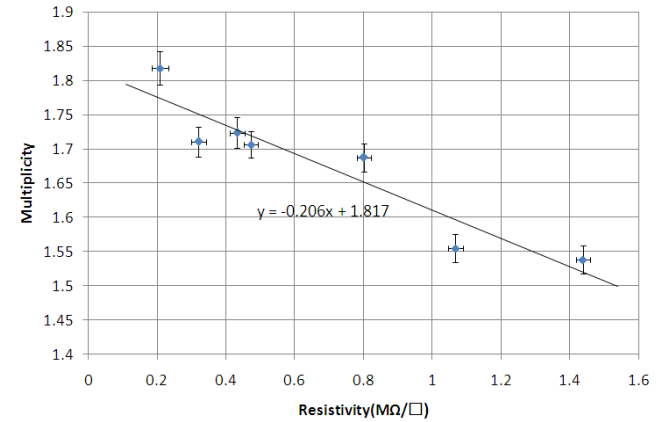

New paint (artist paint) identified

Reasonably cheap

Non toxic

2 component mixture (BLACK and GREEN)

Needs to be sprayed

Production

Has been a struggle

Poor uniformity in a single plate

Mean value not well controlled from plate to plate

Low yield: ~ 60% pass quality cut

Slow – barely match RPC assembly speed

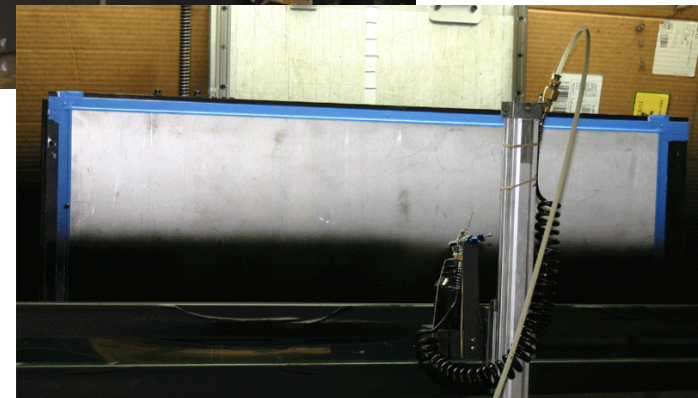

Improving paint spraying

Exhaustive studies of spraying conditions

- Environmental Temperature, humidity
- Airbrush pressure, flow rate, nozzle cleanliness
- Paint ratio and quality
- Horizontal and vertical slide speed
- Air movement in booth

Improvement 1:

- Replaced pneumatic slide with stepper motor
- significant improvement in uniformity

Improvement 2:

- Replaced airbrush with spray gun
- significant improvement in uniformity
- much faster (2 minutes)
- more consistent

We have achieved our goal of spraying 6 plates/day

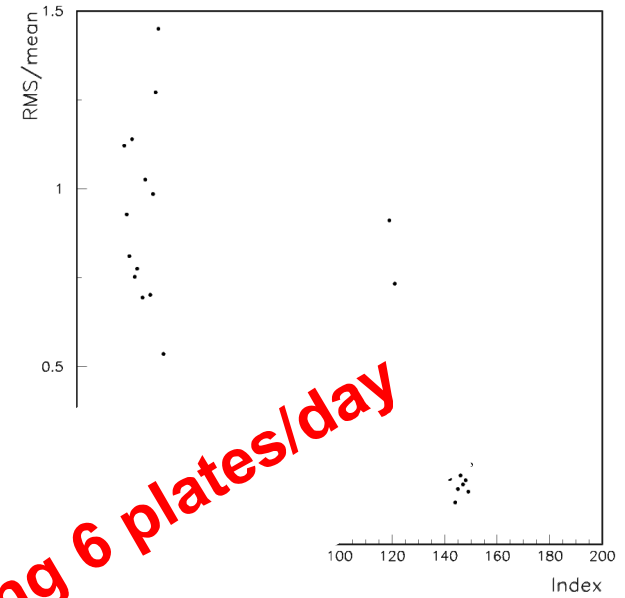

Resist

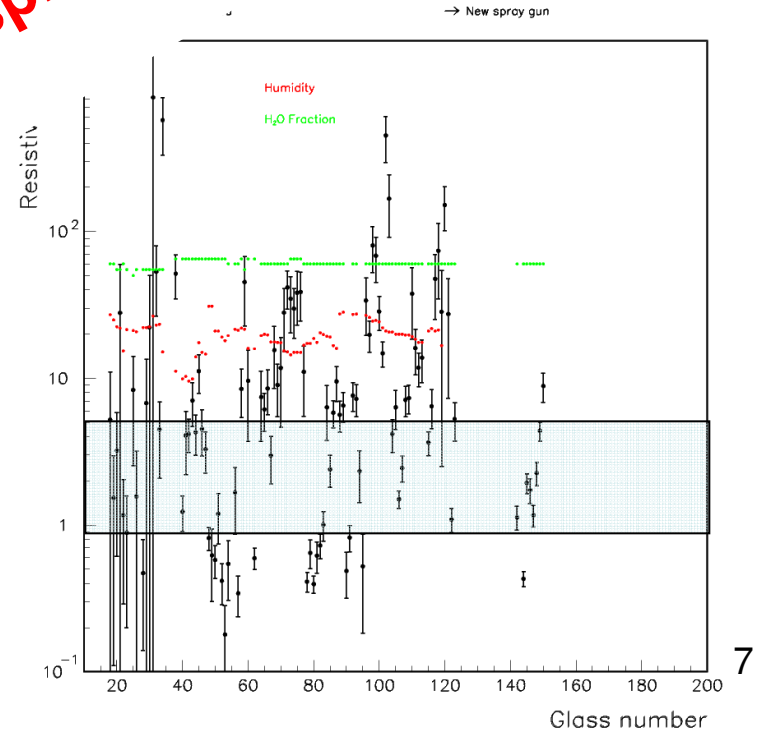
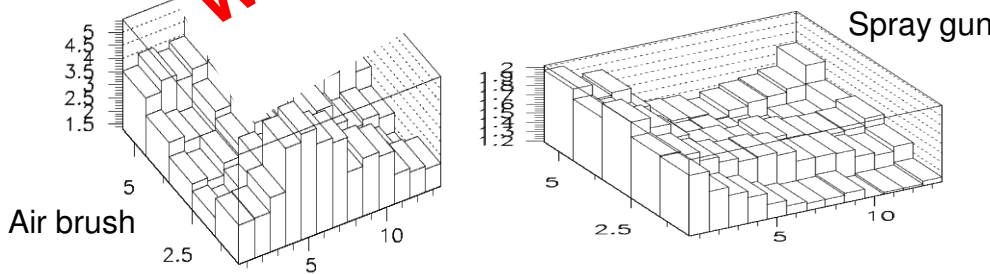

RPC Assembly

Cutting frames

Dedicated (adjustable) cutting fixture
Cut length to .2mm precision
Drill holes

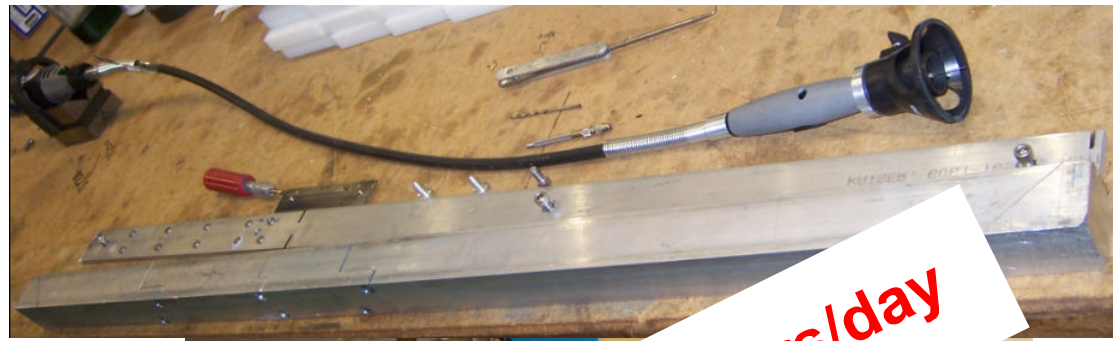

Assembly

Dedicated gluing fixture
Frame/gap glued to ~0.1mm precision
Very time consuming process:
~1 RPC/day/tech, 3 RPC producer



Production

50+ final RPC
Full spec
Completion

We have achieved our goal of producing 3 chambers/day

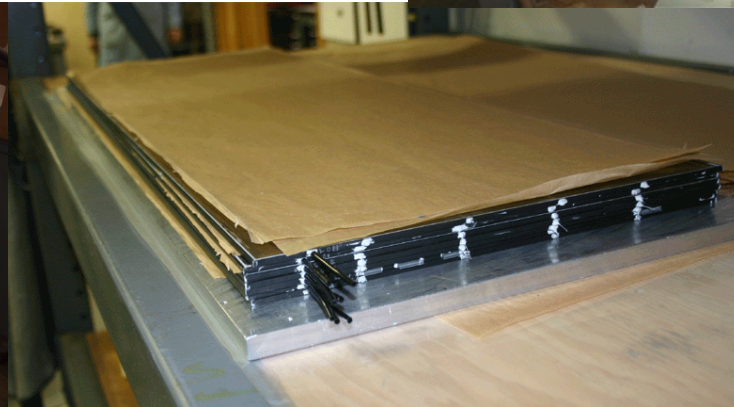
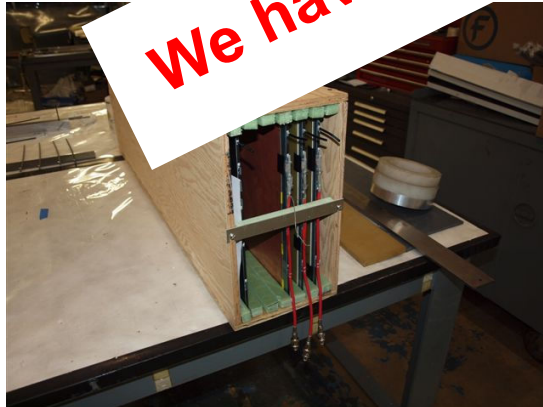

Quality assurance

1 mil = 25 μm

RPC 001

Pressure tests

Test with 0.3 inch of water pressure
Pass if pressure drop < 0.02 inch in 30 seconds
Chambers not passing 1st test are repaired
All repaired chambers passed 2nd test so far

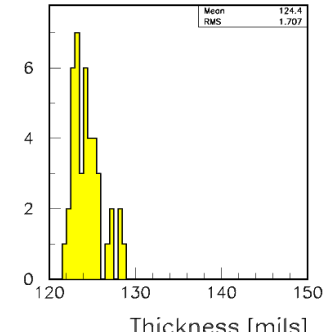
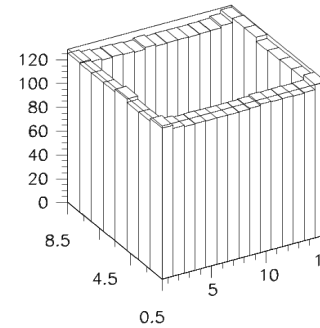

Gap size measurement

Thickness of all chambers measured along the edges
(since glass is very uniform \rightarrow measure of gap size)
Gap sizes at edges within 0.1 mm
(central region uniform due to fishing lines)
Corners typically thicker (up to 0.3 – 0.4 mm)
(only affects very small region)

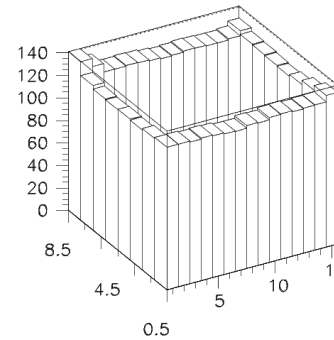

RPC 012

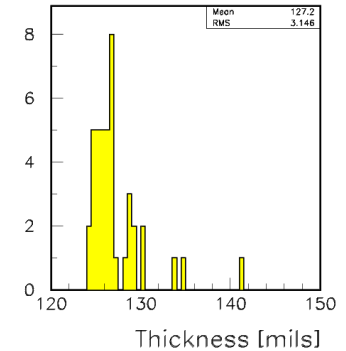

HV tests

Tests up to 7.2 kV before placing readout board on top
(operating voltage is 6.3 kV)

Only 4 rejects so far

2 with two thick sheets of glass
1 with tubing (around fishing lines) wrong
1 with gas inlet/outlet in wrong place, glass cracked

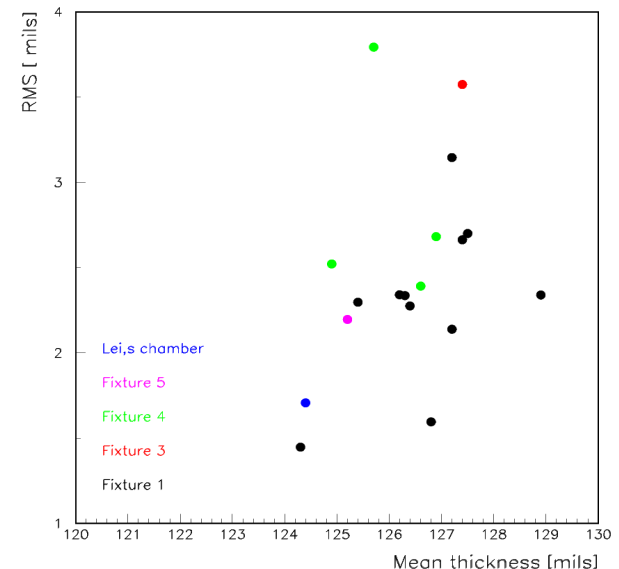

Cosmic ray events with single tracks

Run 675:0 Event 219

Time: 363755
Hits: 9 Energy: xxx mips

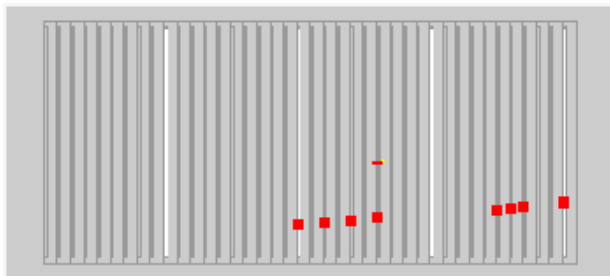
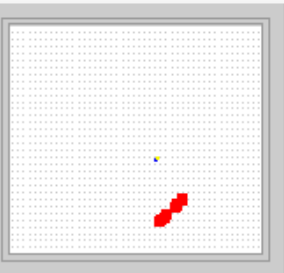

Run 675:0 Event 221

Time: 9998423
Hits: 10 Energy: xxx mips

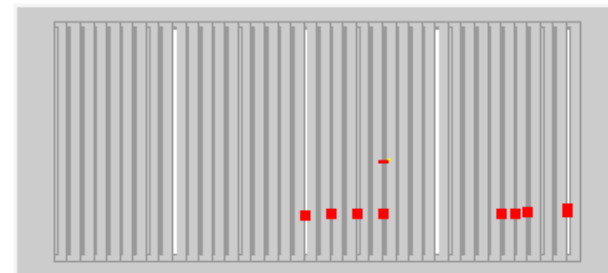
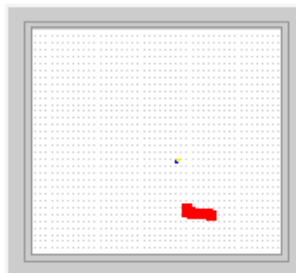

Production chambers with large readout board

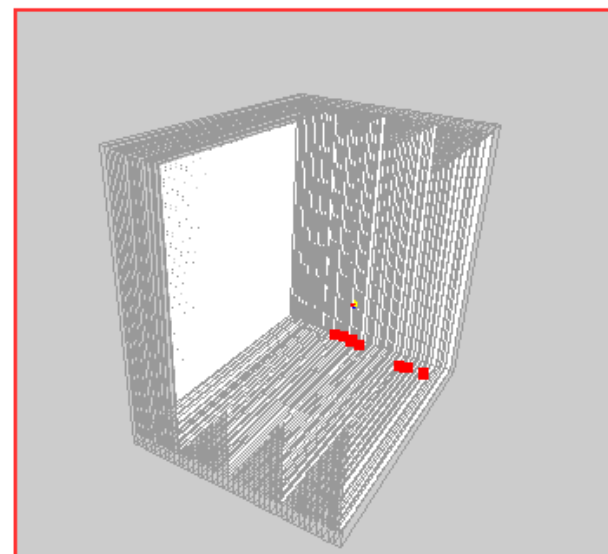
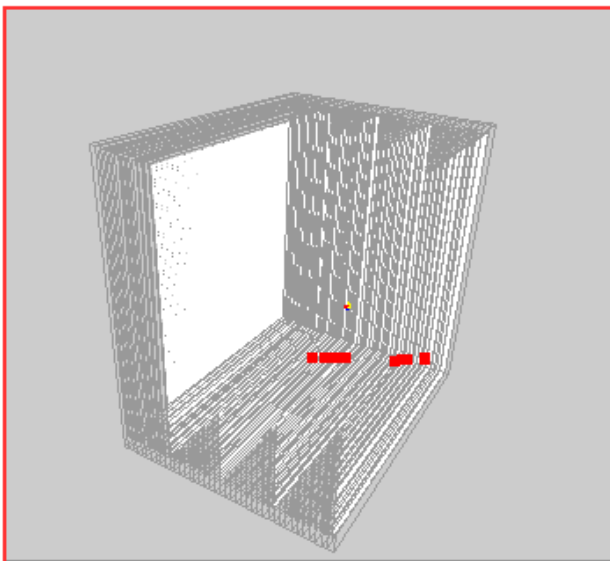

Cosmic ray data analysis in progress

Cosmic ray test stand

Current issue

- Uses scintillator trigger, which only map out 10 x 10 cm²
- Low trigger rate (~10/min)
- Takes for ever to map out entire chamber

Planned changes

- Remove VST chambers and trigger counters
- Expand to ~10 large RPCs
- Run in self-trigger (triggerless) mode

Challenges

- Need new event builder (rely entirely on timing information of hit packages)
- Find cosmic rays within large volume of RPC noise hits
- Worked with VST, should be feasible
- Data size ~ 10 GB/day (need timely data processing)

Cassette test stand

- Completed cassettes to be inserted into hanging file structure for additional tests
- Expect to run in self-triggered mode

Cassettes

Purpose

Protect RPCs, cool front-end ASICs, compress RPCs/FE boards

Design

1 x 2mm copper sheet + cooling tube on top
1 x 2mm stainless steel sheet

Will fit into CALICE Analog HCAL structure
Uses nylon strings to compress the two sheets

Prototypes

First one built with all final dimensions
Tested out with 3 RPCs and 6 FE boards
Assembled again with 3 RPCs and 6 mock-up boards
Inserted into the CALICE Analog HCAL absorber structure

Assembly

Not expected to be labor-intensive



Cassette design: press two plates together

Compression needed

To ensure good thermal contact with ASICs
To ensure good contact between RPCs and pad boards
(minimizes pad multiplicity)

Solution

Use tensioned string between plates
Several candidate strings tensioned to 4 - 5 pounds
No significant drop over 30 days

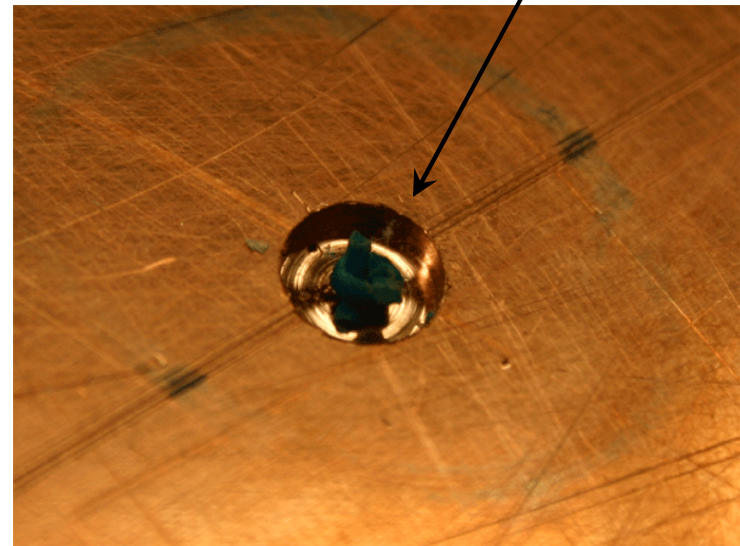
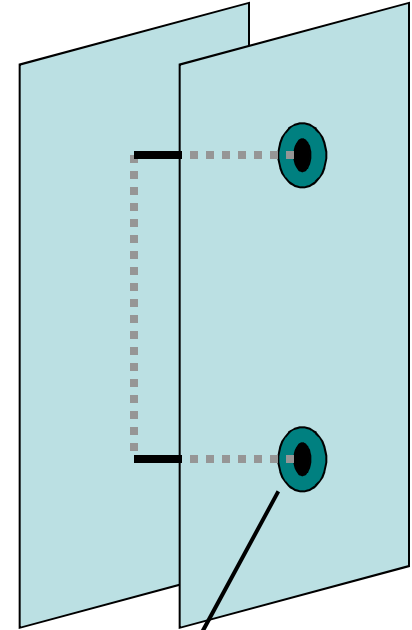
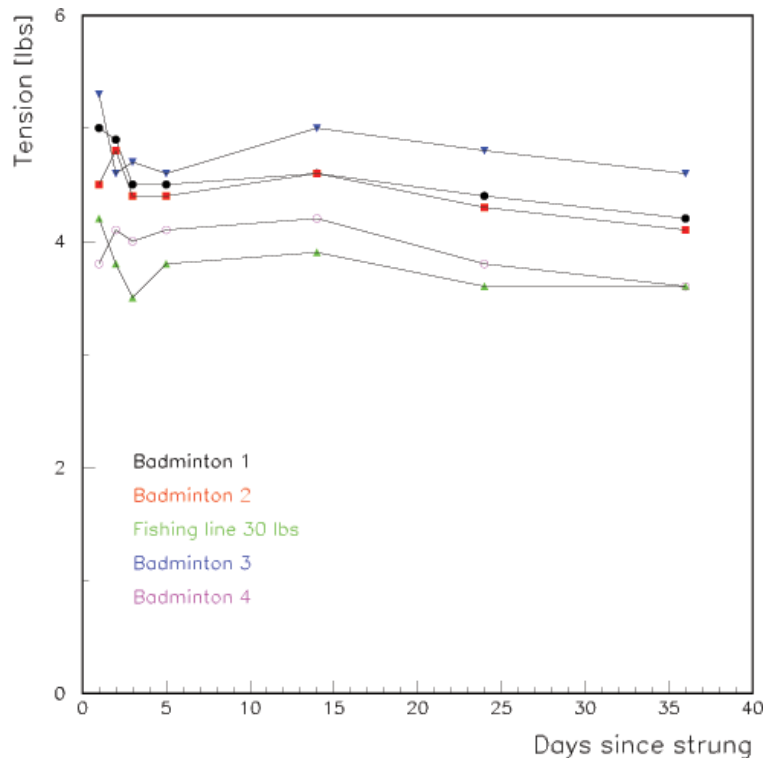

Peripherals

Gas

Mixing rack – done

Distributing rack – almost done

Recently decided not to expand old rack

Parts for a new rack (partially) arrived

New rack assembly in progress



Low Voltage

7 Wiener power supplies in hand

1st distribution box built and in use

Torture tests at full load (8 FE boards) successful

High Voltage

Units in hand

Computer control programs commissioned



Readout system overview

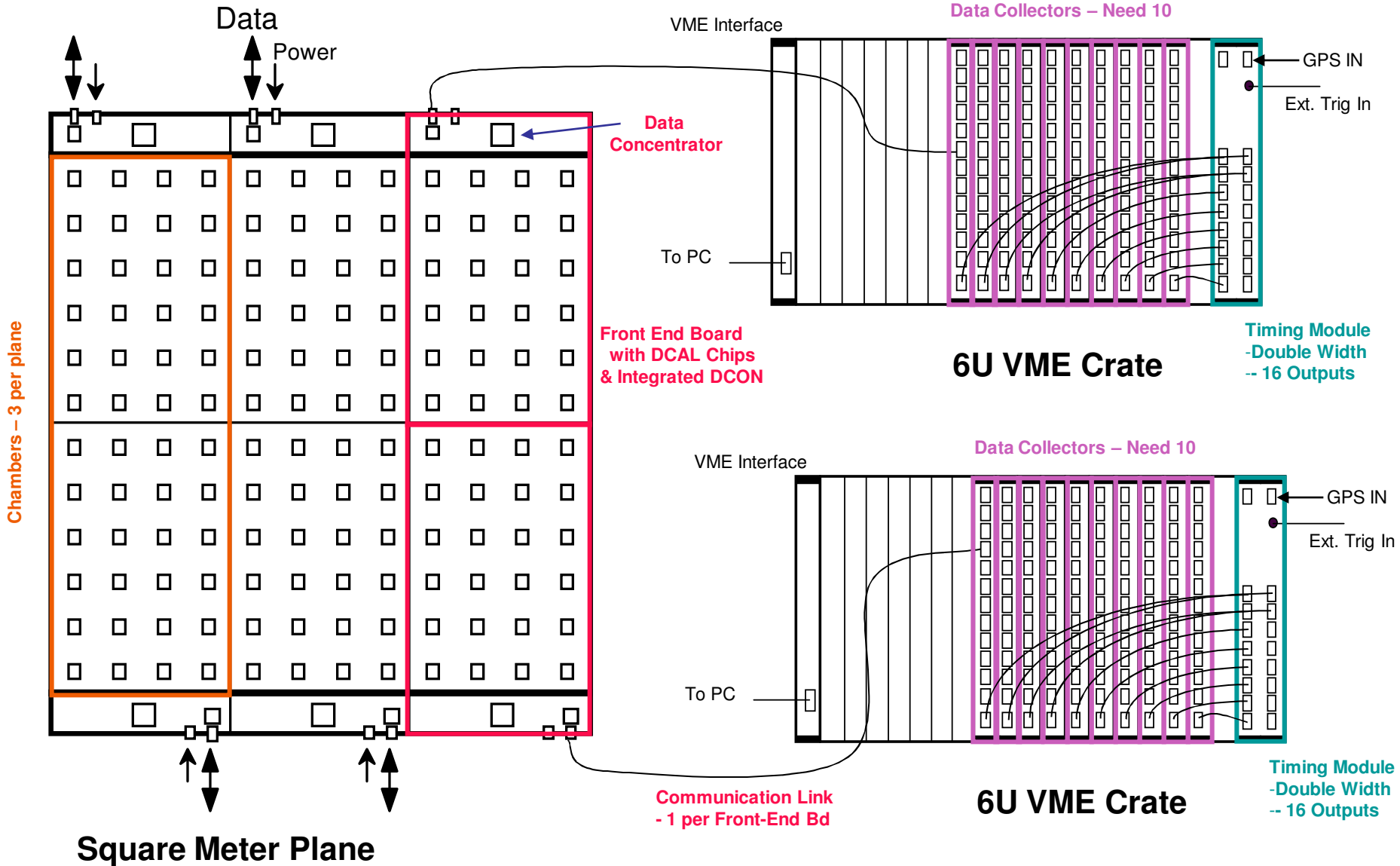

Square meter plane with Readout boards



The DCAL Chip

Developed by

FNAL and Argonne

Input

64 channels

High gain (GEMs, micromegas...) with minimum threshold ~ 5 fC

Low gain (RPCs) with minimum threshold ~ 30 fC

Threshold

Set by 8 – bit DAC (up to ~ 600 fC)

Common to 64 channels

Readout

Triggerless (noise measurements)

Triggered (cosmic, test beam)

Versions

DCAL I: initial round (analog circuitry not optimized)

DCAL II: some minor problems (used in vertical slice test)

DCAL III: no identified problems (final production)

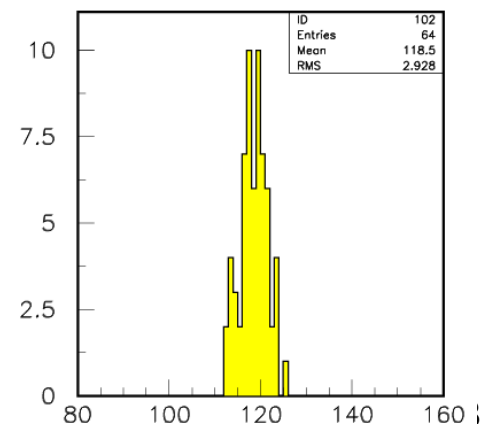
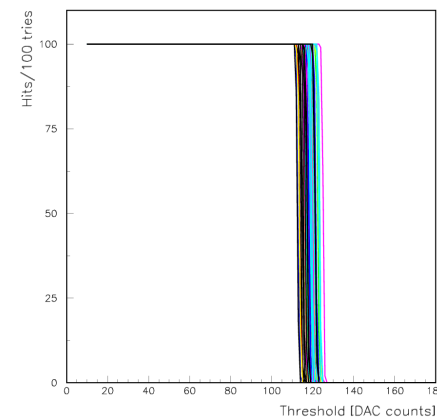
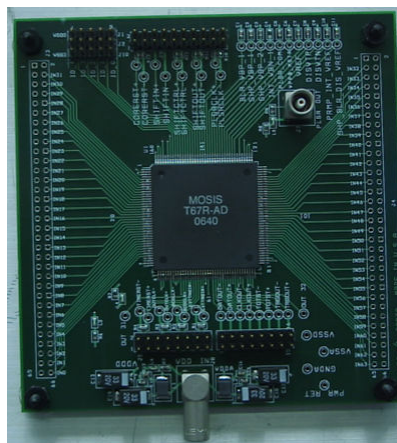
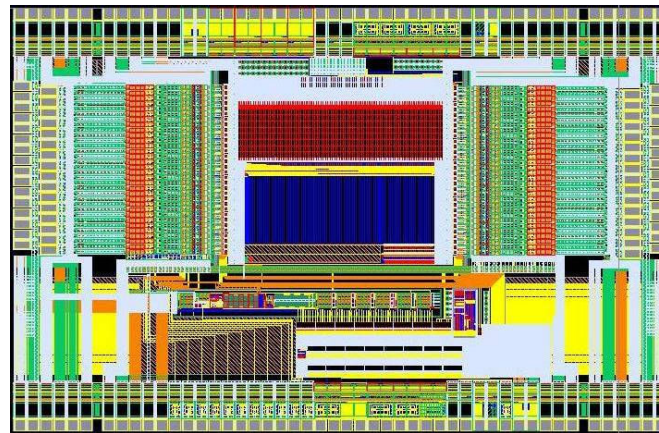

Status of DCAL Production

Chip fabrication

11 wafers, 10,300 chips fabricated and packaged

Chip testing

Extensive tests on a small number of chips at Argonne
Robotic test of all chips at Fermilab

→ 8644 good parts = 84% yield
(need 5472 for cubic meter)

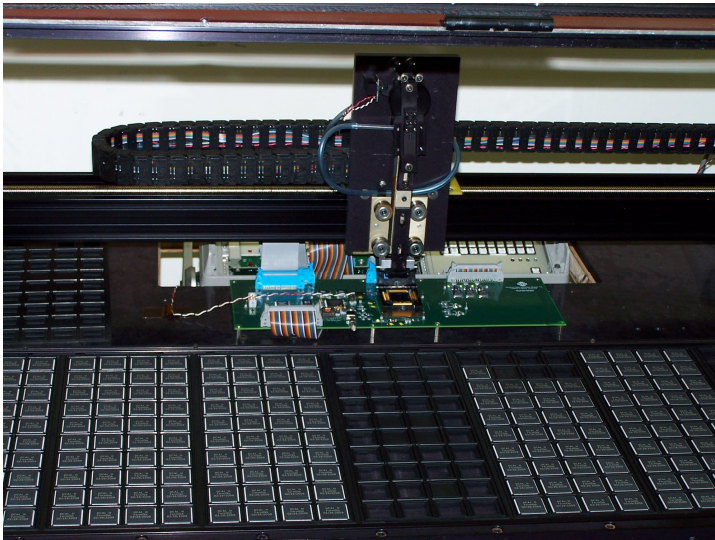

Robotic Chip Tester



Chip Storage (~1/2 total)

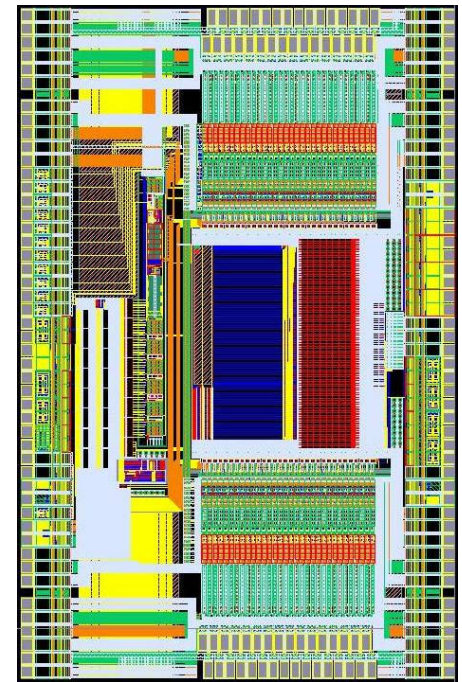

DCAL3 Layout



⇒ **Complete**

Readout Board

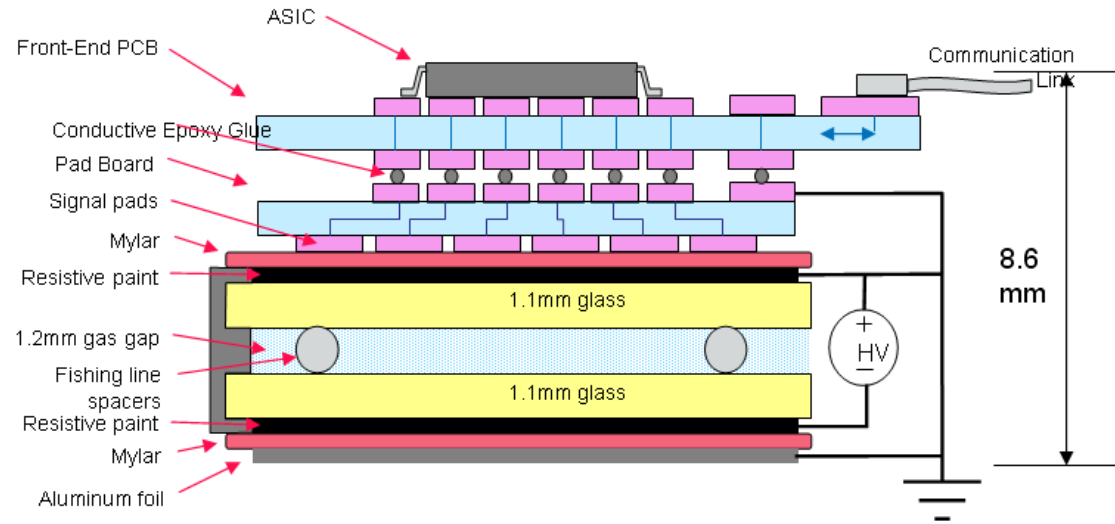
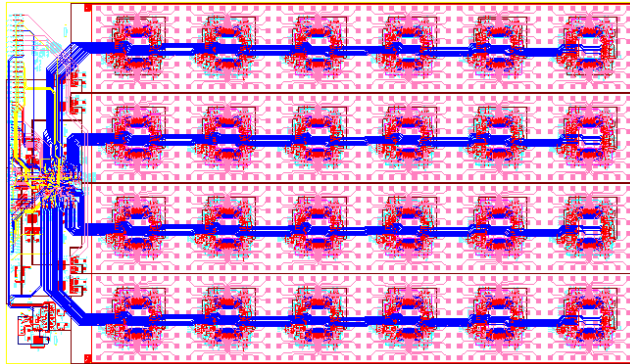

Pad- and Front-end board + Data concentrator = Readout board

Built Pad- and Front-end boards separately
This avoids blind and buried vias (cost and feasibility)
Boards connected with conductive epoxy

Status

- 9 boards built and checked in 4 versions
- 8 boards glued and tested with RPCs
- Torture tests: operation 100% error free
- Data concentrator firmware finalized
- 300 Boards being fabricated (expected back soon)

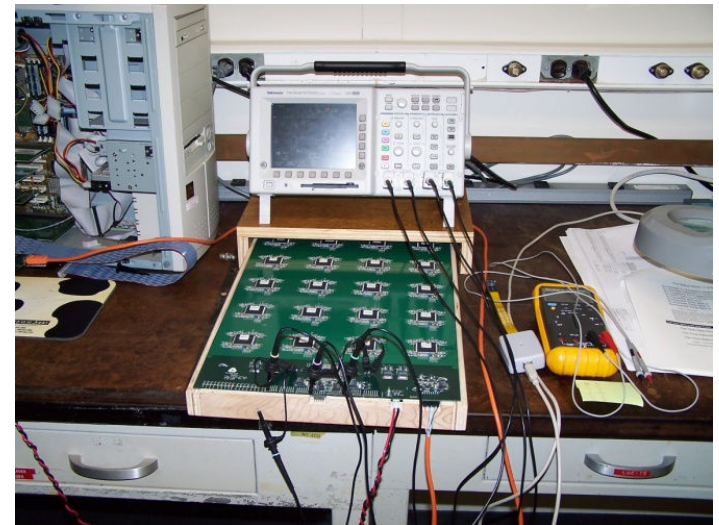

Gluing fixture for Pad- and FE-boards

Challenge: 1536 glue dots in less than 3 hours

Fixture

Designed, built and commissioned

Practice

Glued 8 full size boards successfully

Production

~55 minutes needed/board
can glue up to 6 boards/day

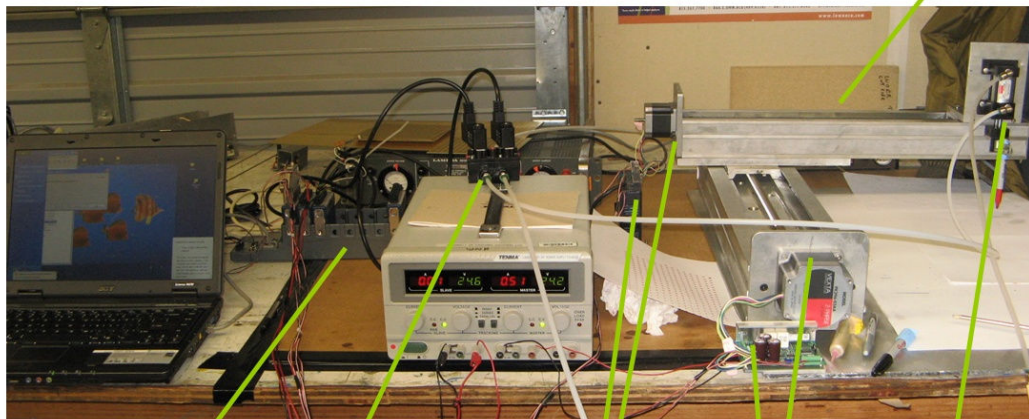
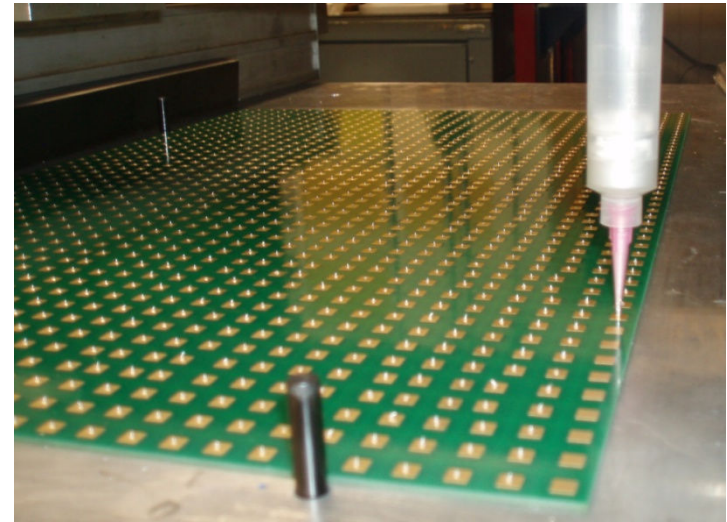

Glue Dispenser

Controller

Solenoid valve

x axis motor and driver

y axis motor and driver

z slider

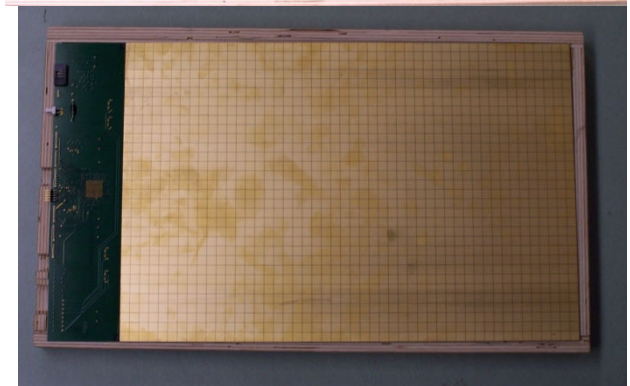
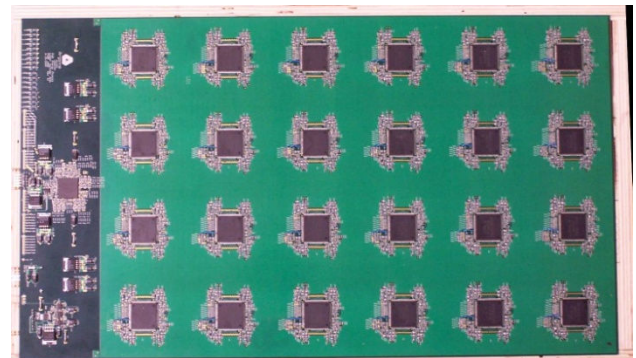

Measurement of electronic noise floor

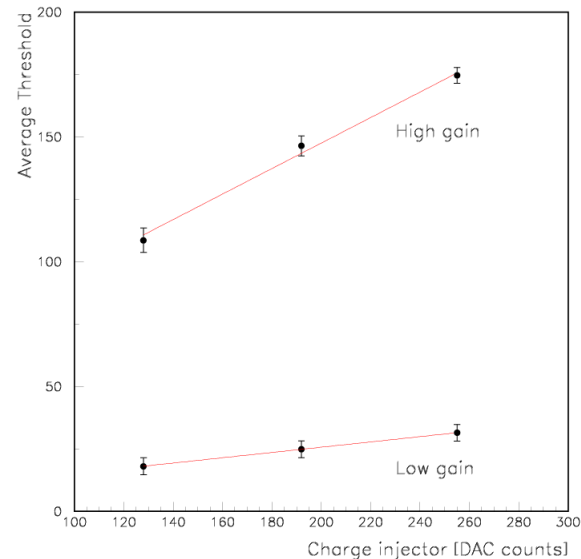
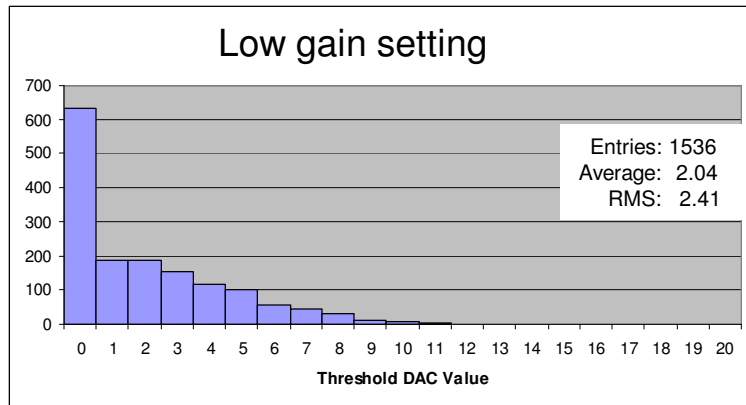
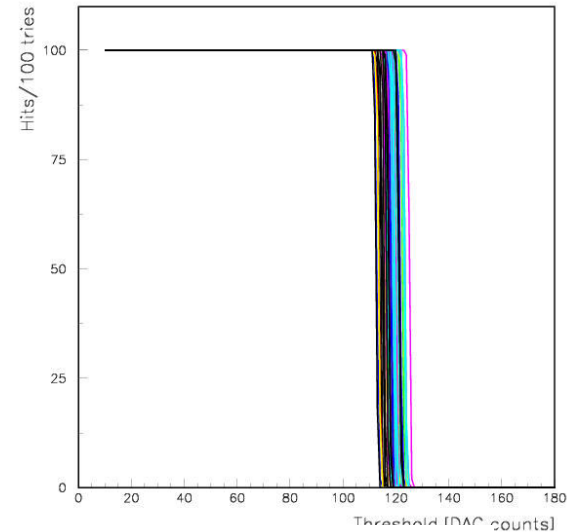
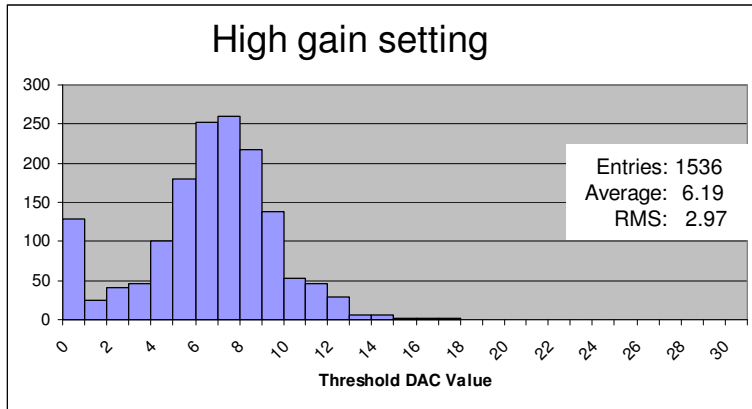

High Gain:
~0.3 fC / THR_DAC_CNT
→ 75 fC Range

↑
Factor of 6.4
↓

Low Gain:
~1.9 fC / THR_DAC_CNT
→ 480 fC Range
→ Operate ~ 190 fC for RPC

Measurements of Noise Floor

Single channel measurements,
Ext. Trig., No Pad Bd, No Chamber, No HV
Entire Front End Board, 1536 Channels

Back-end readout

Data Collector (DCOL)

30 produced (20 needed for cubic meter)
Testing 75% done
Firmware finalized

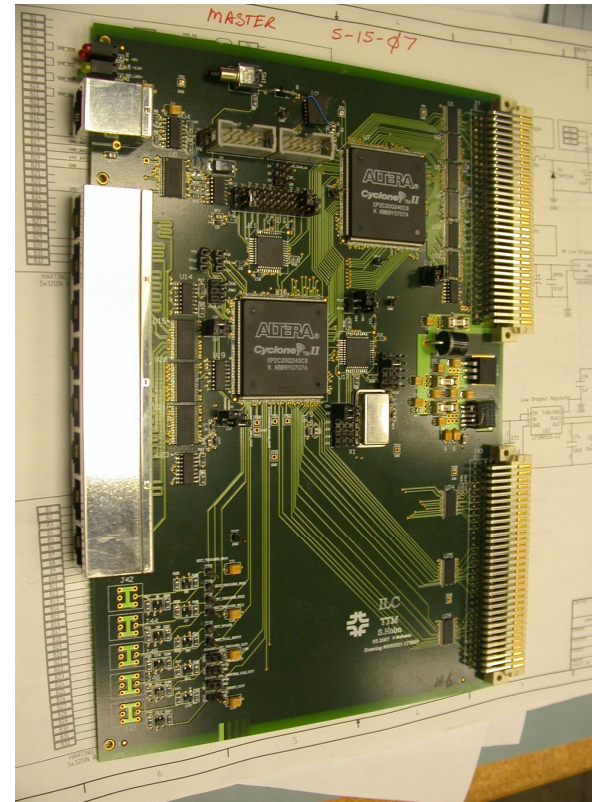
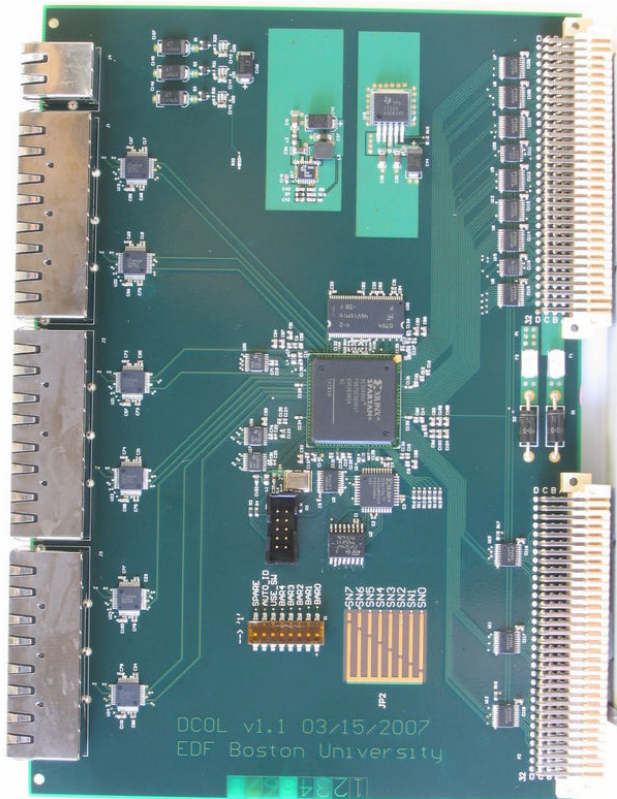

Timing and Trigger Module (TTM)

Redesign

1 Master and Slaves (in different crates)
Added outputs 8 → 16
Design finalized

10 being fabricated (3 needed for cubic meter)

Software

Online software

Based on CALICE system
Development 99% complete
Ready to integrate with CALICE Silicon – W ECAL and TCMT

Event builder

Somewhat tricky: sort data for matching timestamps
Java version operational in Cosmic Ray test stand
New C++ version being developed
Implementation of analysis of trigger-less Cosmic Ray data

Event display of simulated 60 GeV π^+

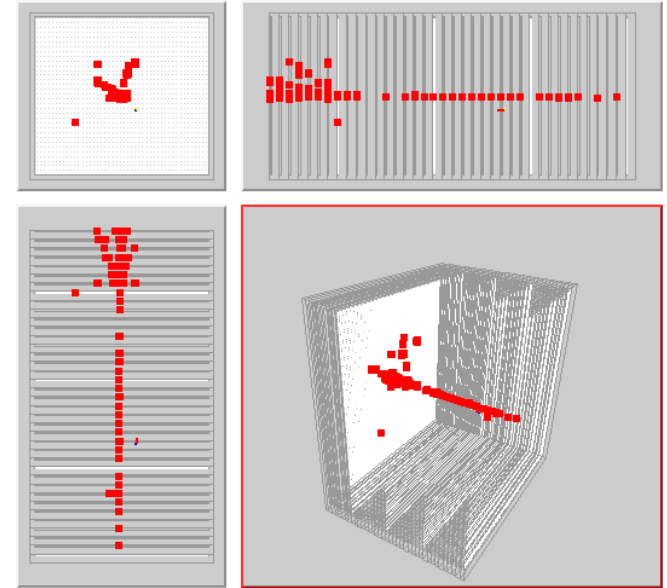

Event display

Ready

MC simulation

Simulation of cubic meter in GEANT4
Now implementation into MOKKA
Will keep standalone RPC simulation

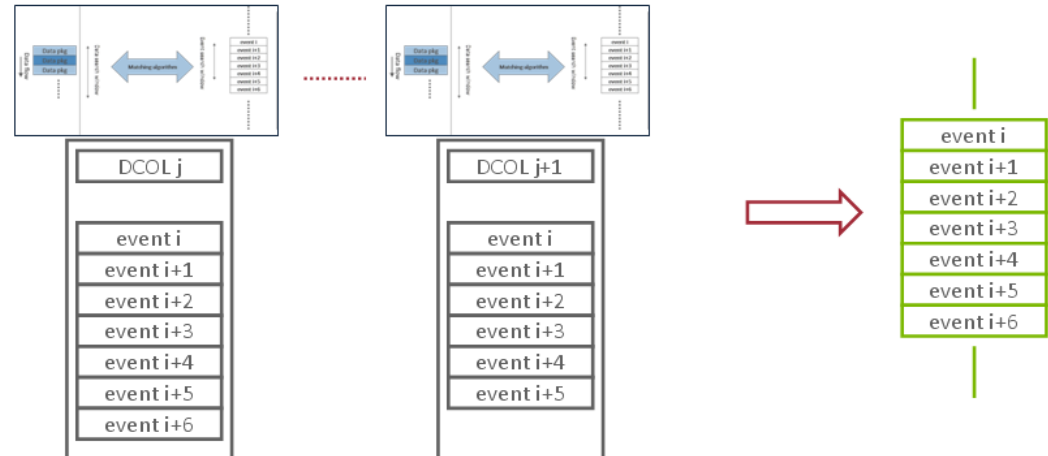

Physics prototype plans

Task	Dates	Comments
Construction	Complete by June 30 th	Should not slip much more...
Cosmic ray testing of cubic meter	April through August	
Installation into Mtest	in September	
1 st data taking period	October	DHCAL standalone (with TCMT)
2 nd data taking period	December	Combined with ECAL
3 rd data taking period	Early in 2011	DHCAL standalone or combined
Disassembly and shipping of stage	March 2011	Hard deadline

← Officially on Mtest schedule

← Maybe not so hard