

GEM-based Digital Hadron Calorimetry for SiD

Andy White

For the GEM-DHCAL Group

U. Texas at Arlington, (and SLAC)

GEM/DHCAL active layer concept

GEM-BASED DHCAL CONCEPT

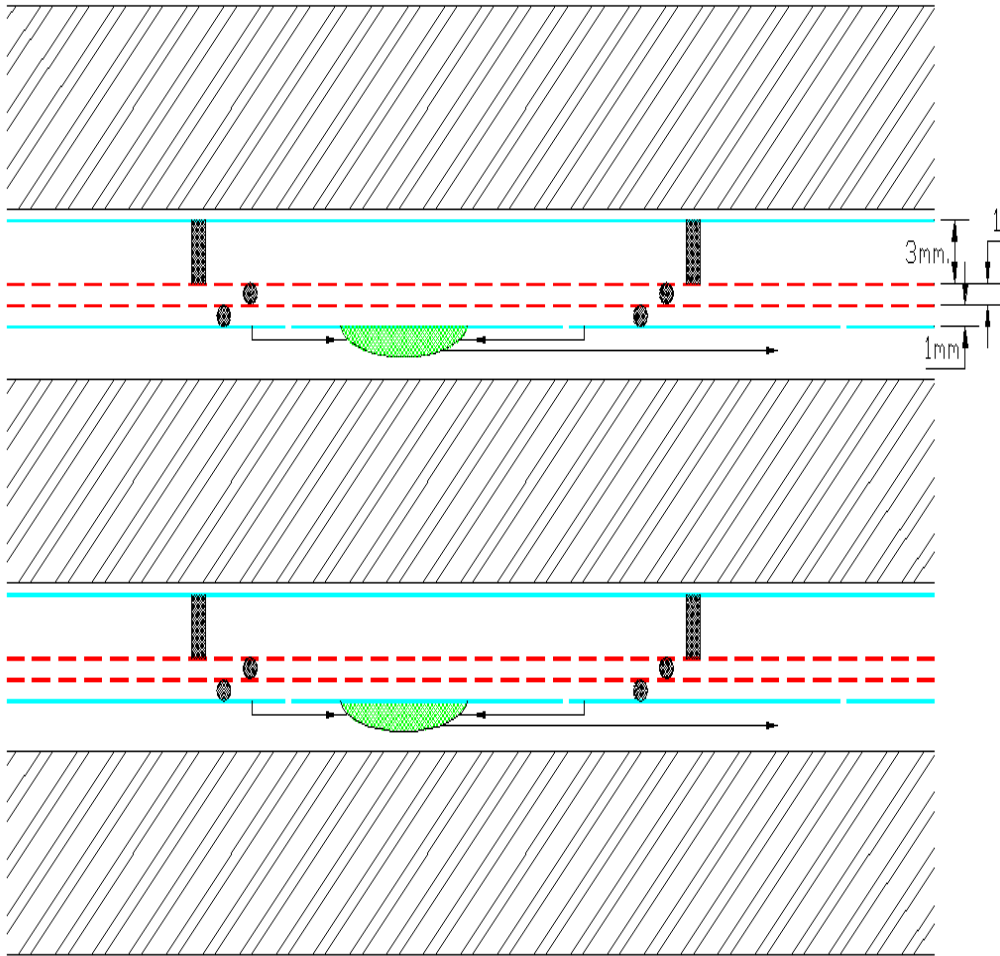

NOT TO SCALE

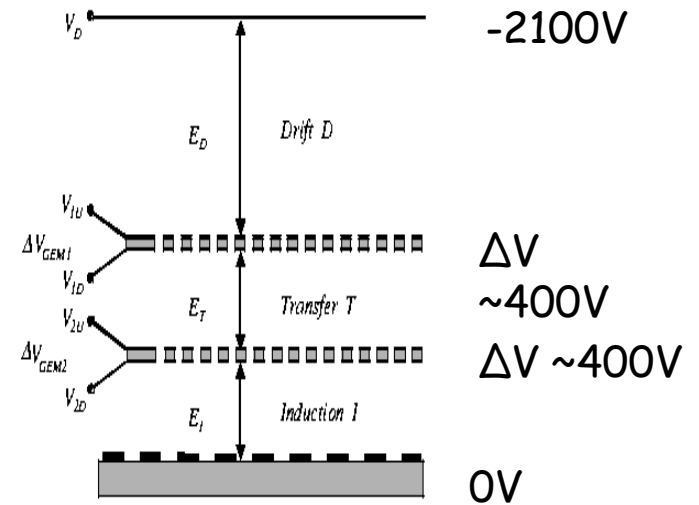
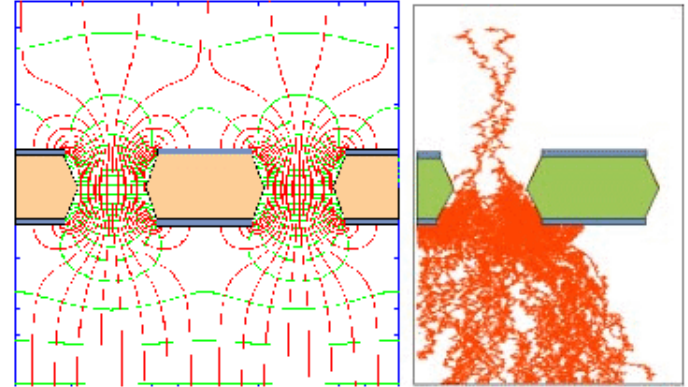

Fig. 1: Schematics of a double-GEM detector.

GEM DHCAL Developments

- GEM detector with an optimal gas flow spacer design constructed and integrated with SLAC KPiX V7 (64-channel) readout.
- Two dimensional readout of 30cm x 30cm chamber using KPiX successful.
 - Benchmark Fe^{55} from single channel analog electronics
- Three additional 30cm x 30cm chambers constructed.
 - One at ANL for DCAL chip readout testing (for 40-layer stack)
 - Two at UTA for continued chamber characterization
- Completed the design of 30cm x 100cm GEM foil.
 - Construction of first five 30cm x 100cm foils has begun at CERN GDD workshop, Feb. 2010
- Mechanical design considerations for large chamber construction in progress.

30cm x 30cm GEM with 8x8 pads

Chamber

➤ GEM Foils(3M)

- 310x310 mm²
- Active area : 280x280 mm²

➤ Active gas room

- 350x350x6 mm³ → For 3/1/1 gaps(d/t/i)

➤ 64 readout channels(1x1 cm²)

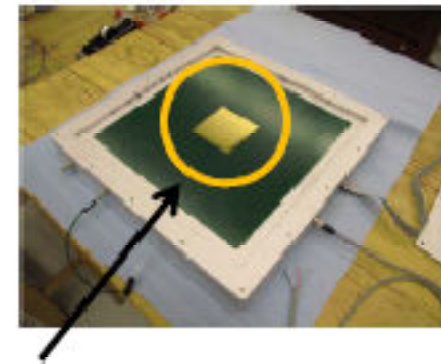
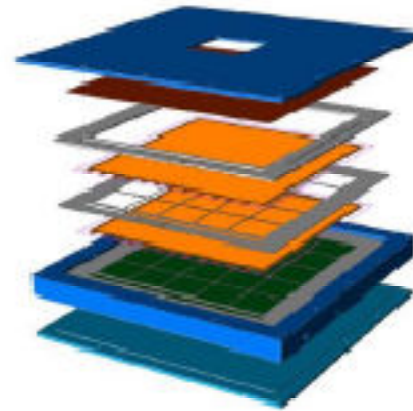

64-readout pads

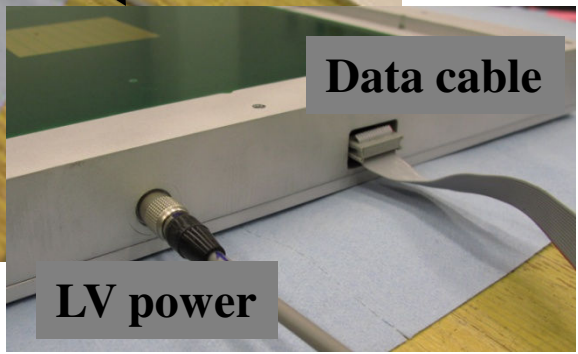
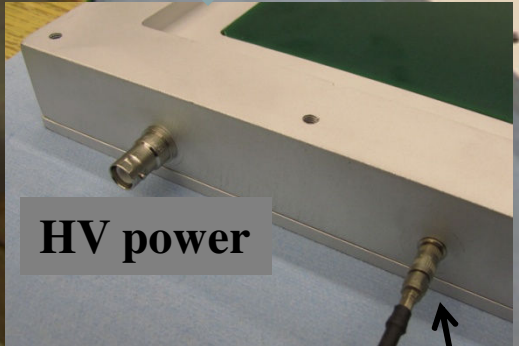
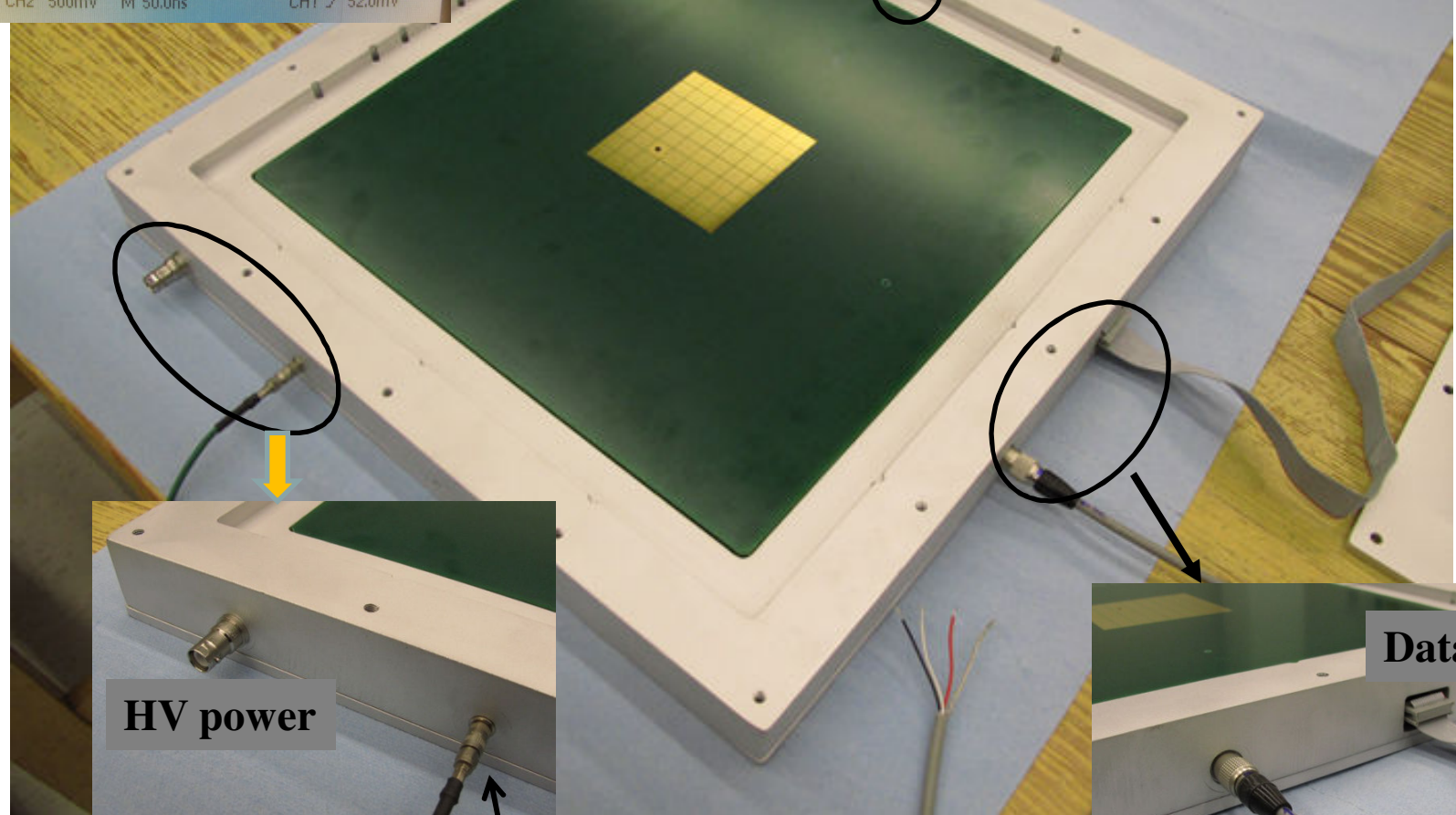
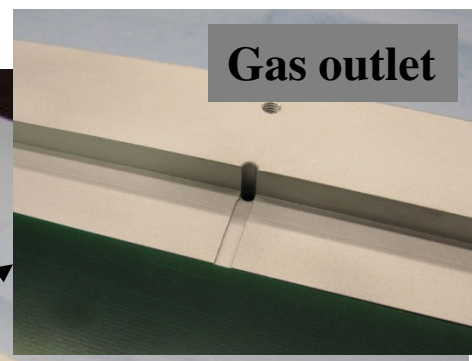
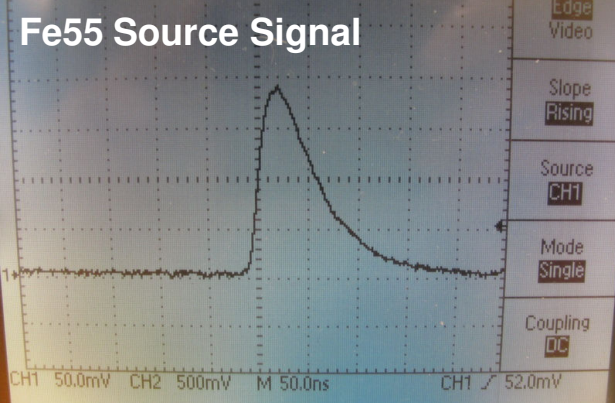

30cm x 30cm GEM with 8x8 pads

Typical Fe55 spectrum from an Ar-based gas detector

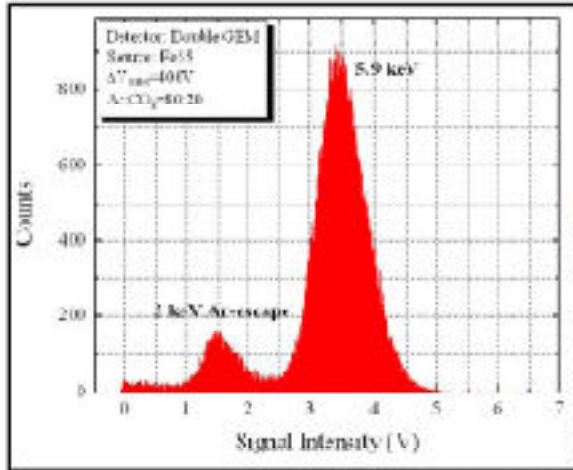

bleValue_c39_b0

Readout:
A225+A206(AmpTek)

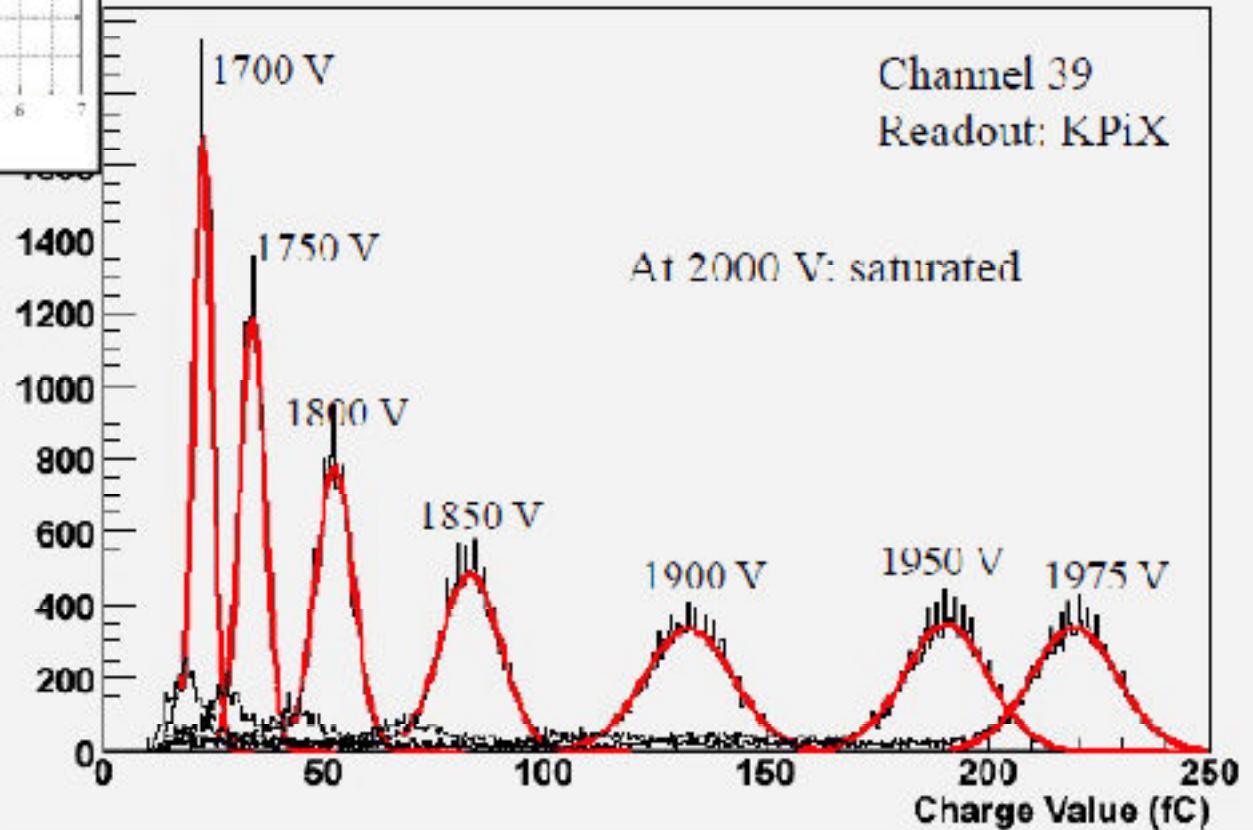

30cm x 30cm GEM with 8x8 pads

Chamber gain increases nonlinearly with high voltage

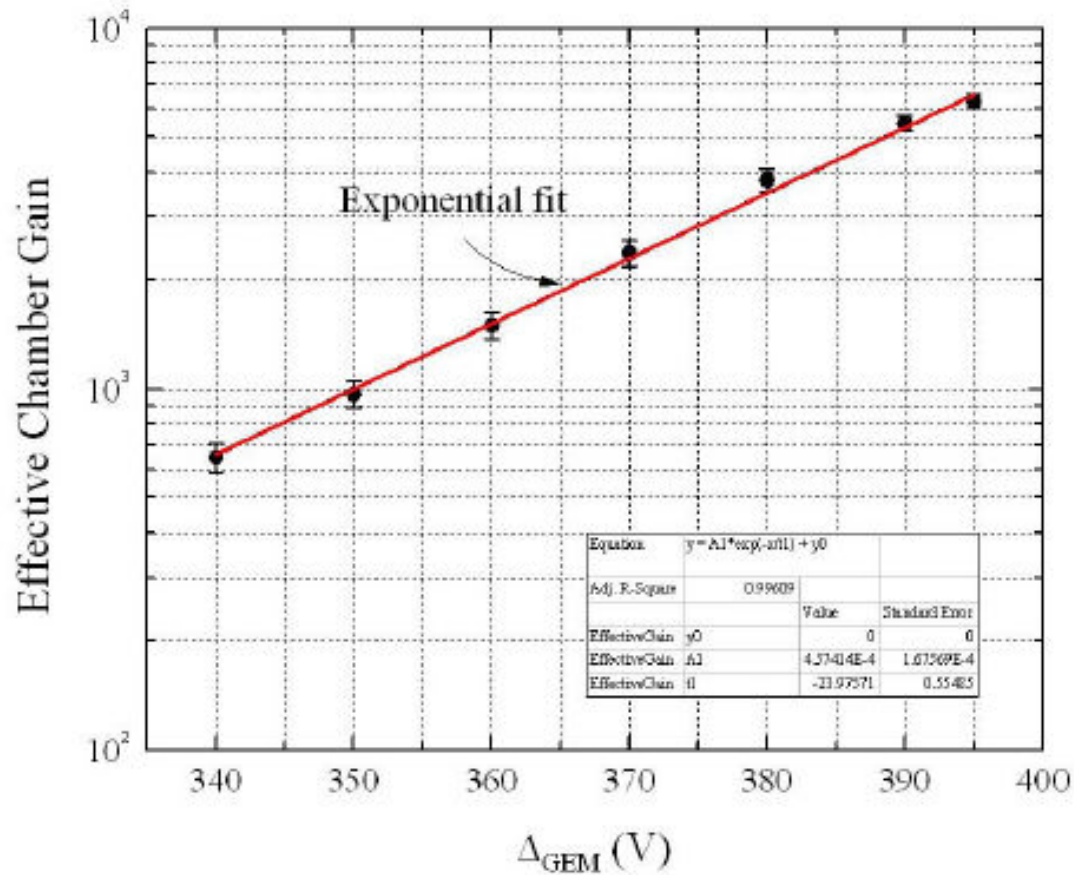

30cm x 30cm GEM with 8x8 pads

HV = 1950V ($\Delta V_{\text{GEM}} = 390$ V)

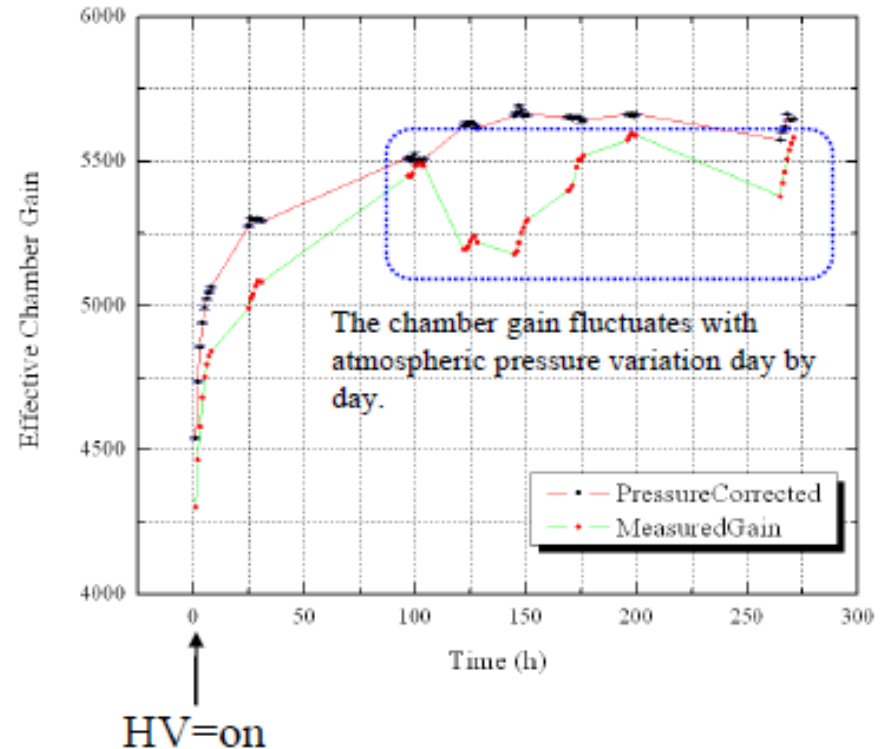
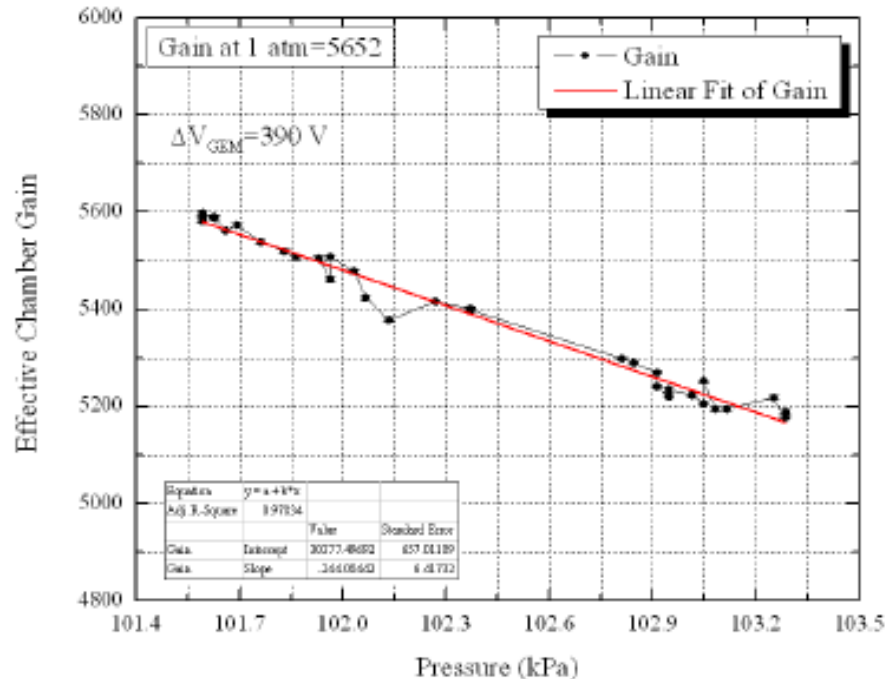

We use an open gas system (gas flows at atmospheric pressure).

Thus, pressure inside chamber is affected by the atmospheric pressure directly.

This pressure change affects the chamber gain.

The chamber gains were recalculated to the values at 1 atm.

Map for Fe^{55} GEM+KPiX7

Source (Fe^{55}) was put on the detector window
Each histogram corresponds to each anode pad on
the readout board.

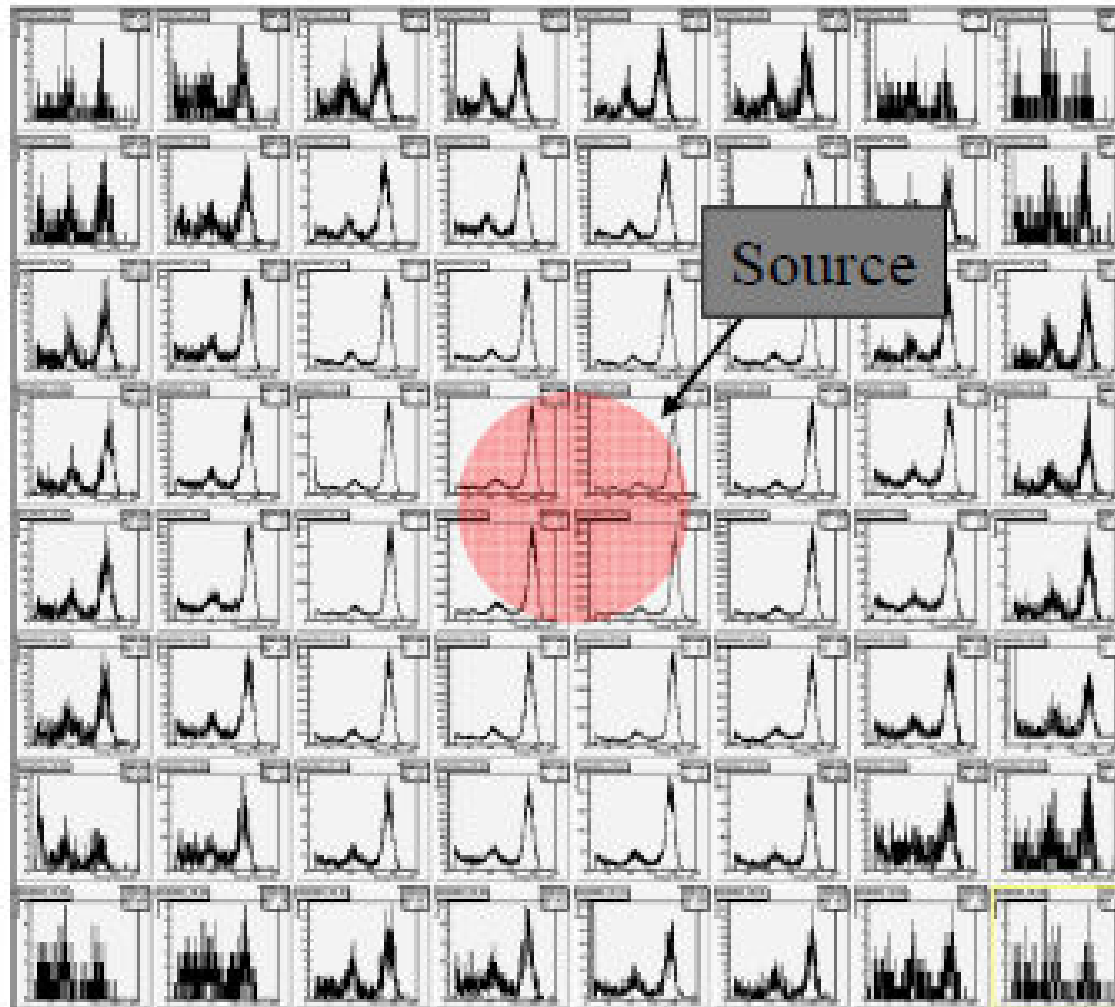

30cm x 30cm GEM with 8x8 pads: ^{106}Ru

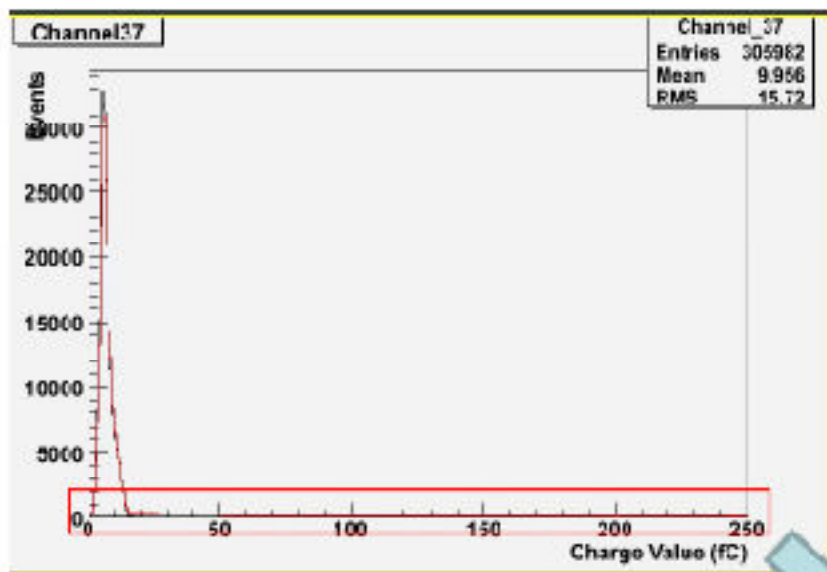

Ru106, 1960V, ST=2.4V=2 fC
Background, 1960V, ST=2.4V=2 fC

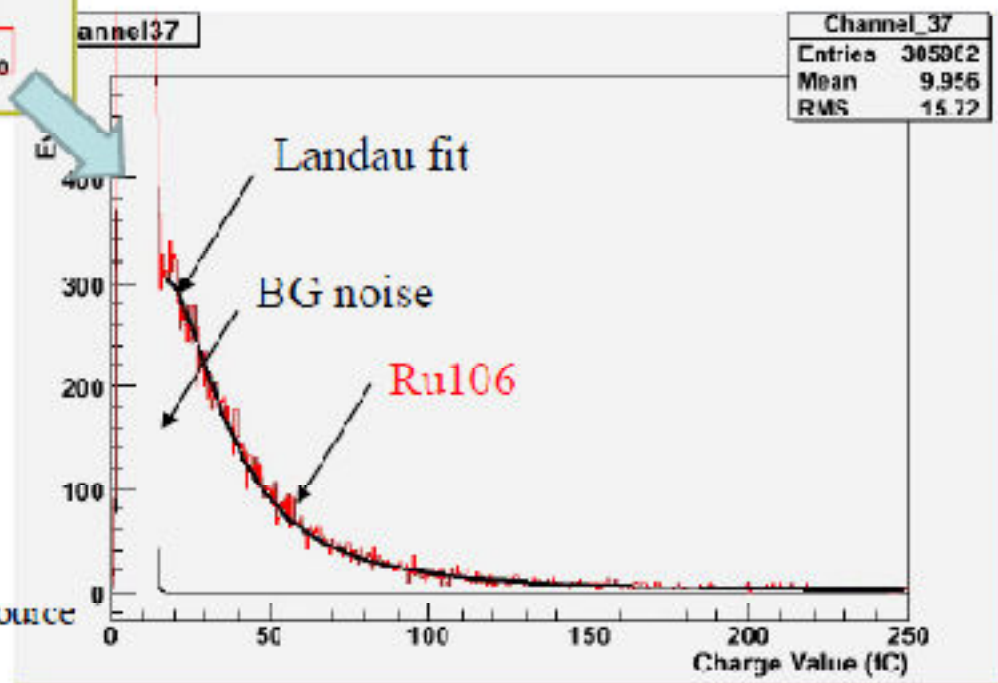
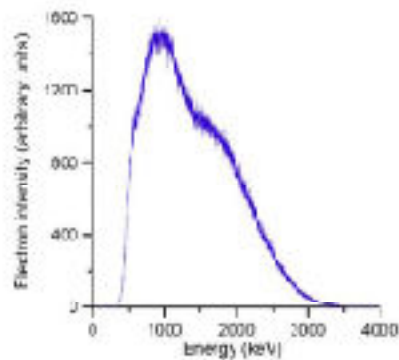

Energy spectrum of Beta emission from a Ru106 source

30cm x 30cm GEM with 8x8 pads: Bkgd

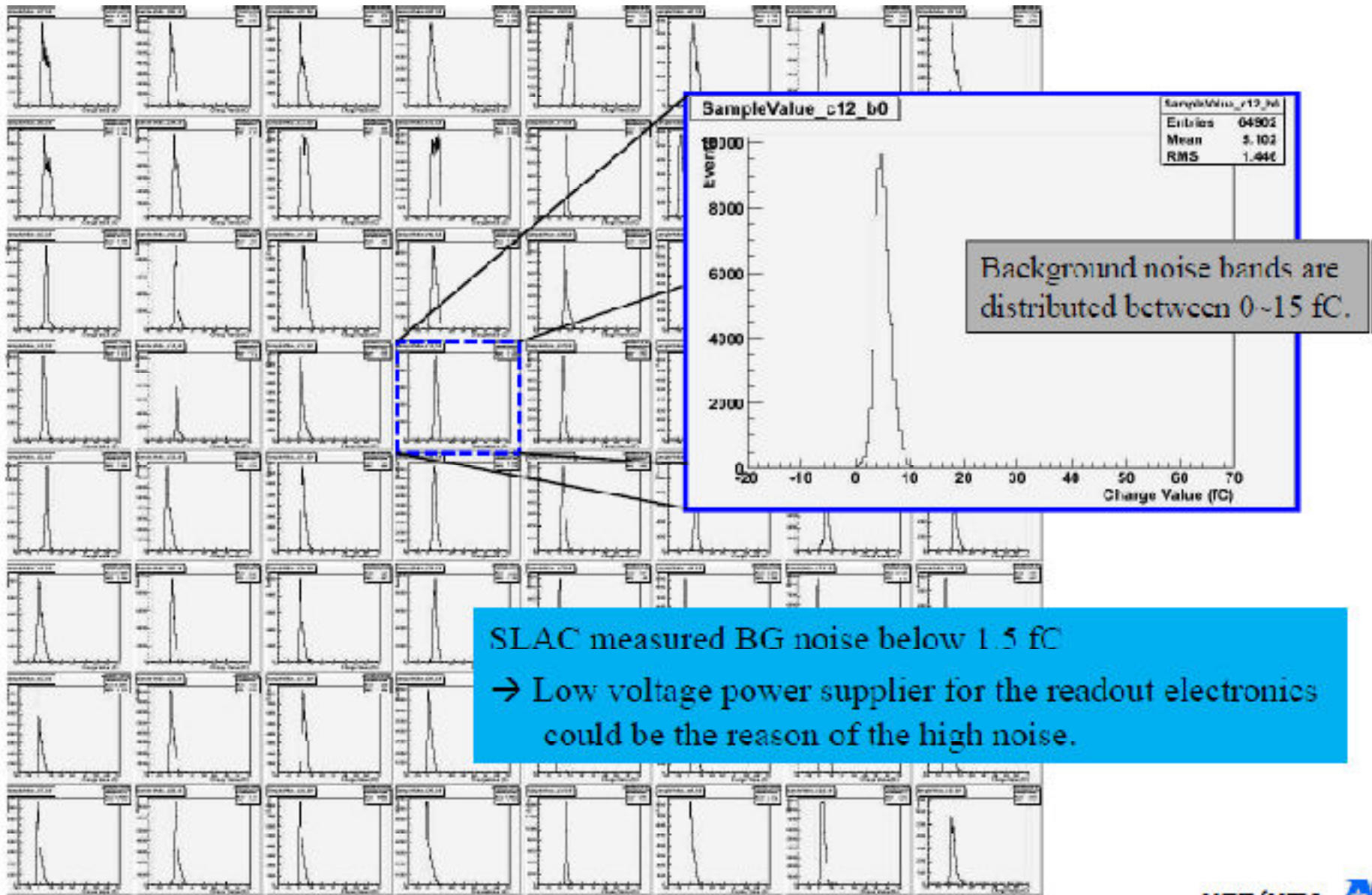

30cm x 30cm GEM with 8x8 pads: ^{106}Ru

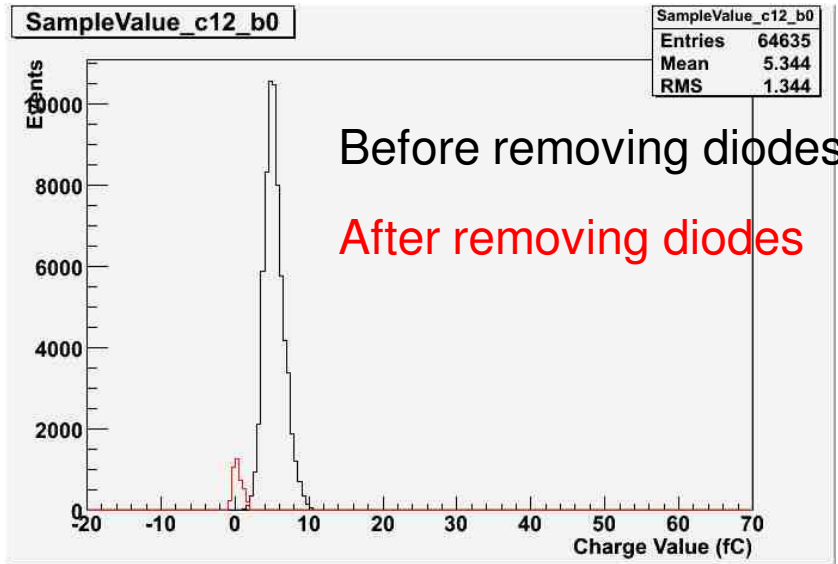

Not all e^- are Min-I in chamber (+ range of angles) \rightarrow use cosmics/beam for next tests

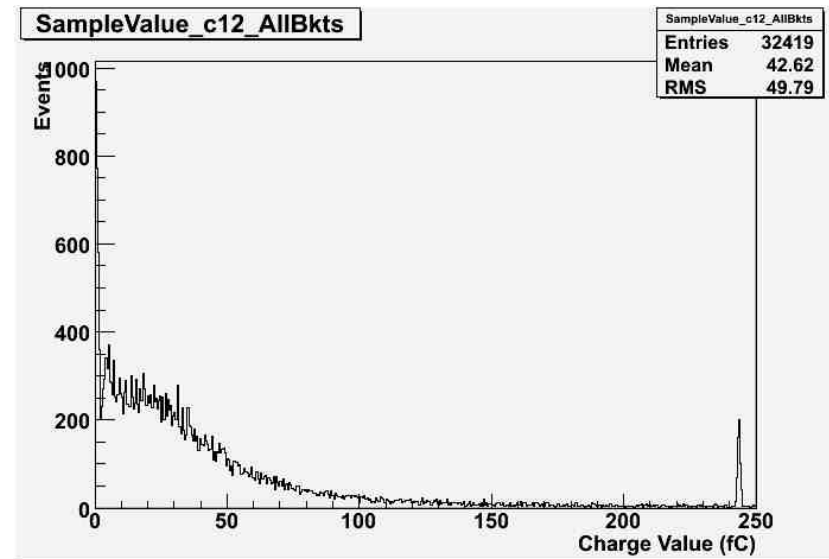

30cm x 30cm GEM with 8x8 pads: ^{106}Ru

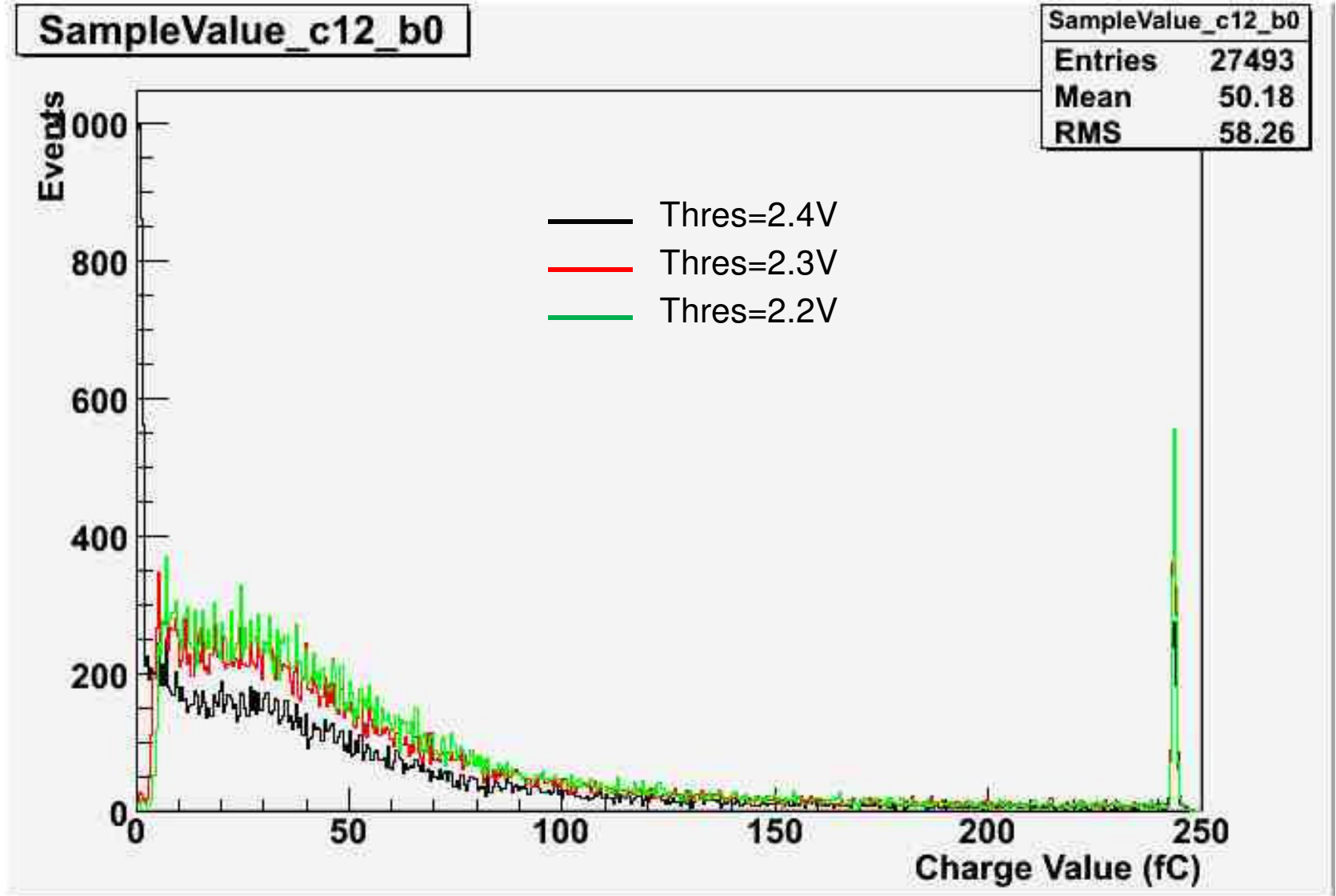

GEM DHCAL Plans

- Through mid 2010
 - Complete 30cm x 30cm chamber characterization using radioactive source, cosmic ray and particle beams
 - Need to understand electronic noise affecting MIPs
 - Start producing 33cm x 100cm GEM foils
 - Begin construction of 33cm x 100cm GEM unit chambers and characterize them using source, cosmic ray and particle beams
- Mid 2010 - Late 2011
 - Complete construction of fifteen 33cm x 100cm chambers and construct five 100cm x 100cm GEM DHCAL planes
 - Beam test GEM DHCAL planes in the CALICE beam test stack together with RPC
 - If available construct TGEM chambers (initial test of a 10 x 10 cm² TGEM board with KPix-7 readout set for May at the Weizmann Institute)

30cmx100cm GEM Foil Design

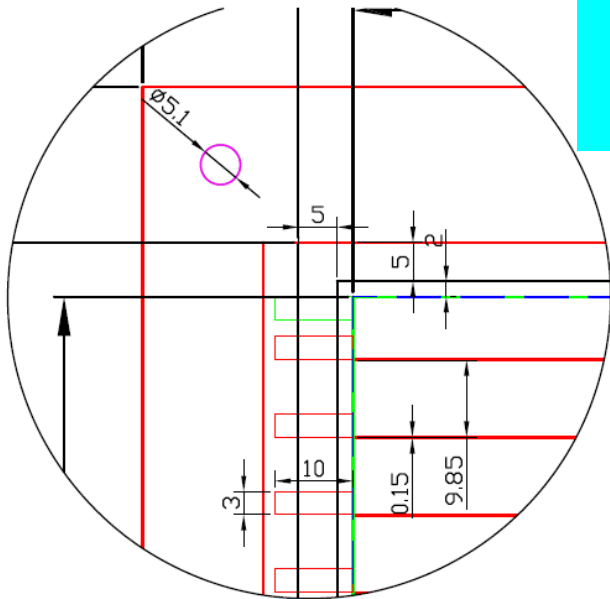

Active area $468 \times 306 \times 2$ mm²

Number of HV sectors = $32 \times 2 = 64$

HV sector dimension = 9.9×479.95 mm²



33cmx100cm DHCAL Unit Chamber Construction

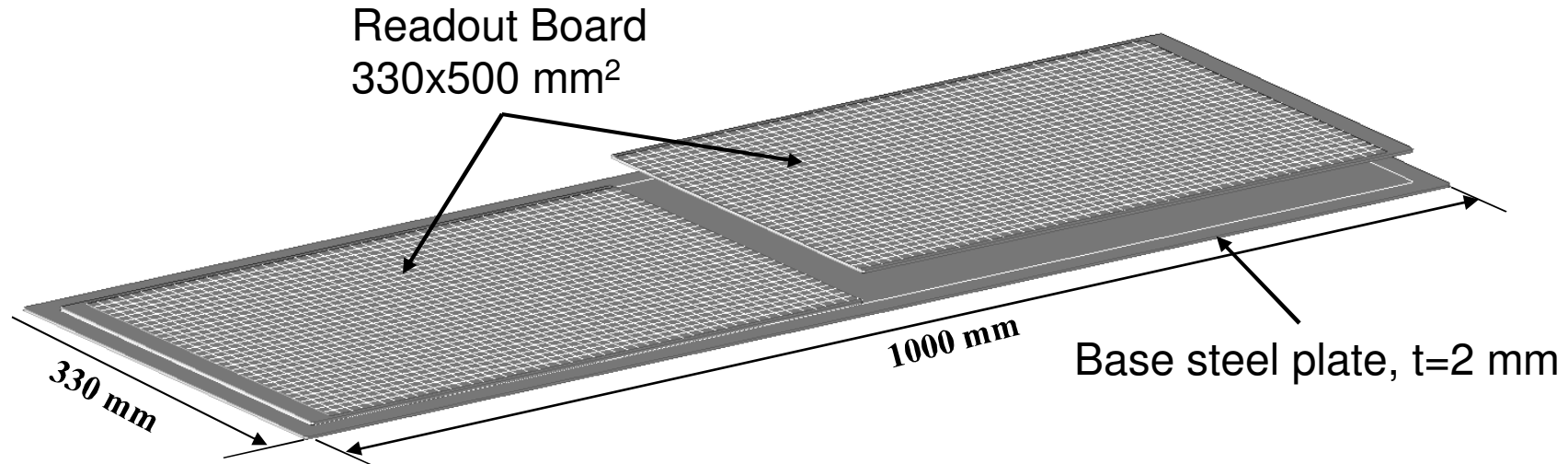

2mm steel strong-back + thin cathode layer

3mm

1cm thick support
from G10 spacers

1mm

1mm

1mm pad board

2mm FE board

GEM DHCAL Report

1mm assist strong back

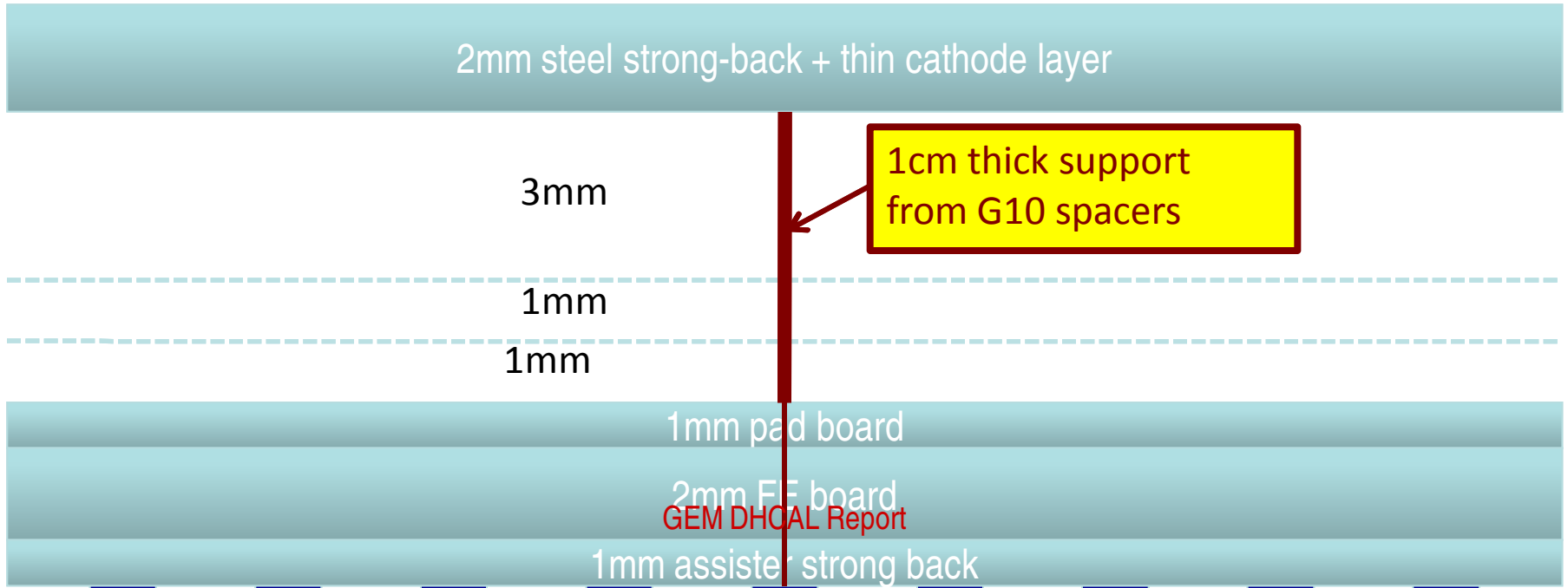

UTA's 100cm x 100cm Digital Hadron Calorimeter Plane

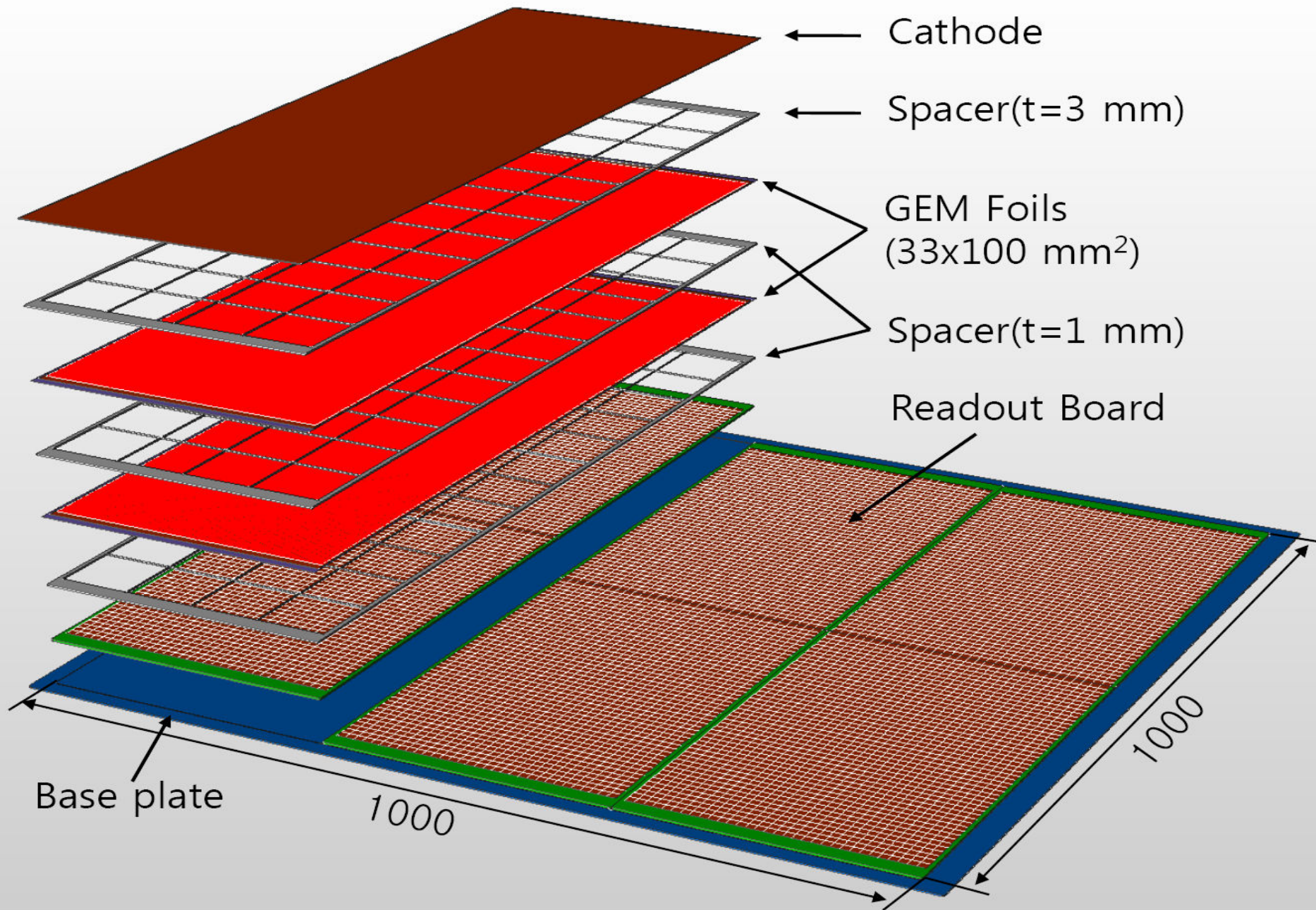

UTA's 100cm x 100cm Digital Hadron Calorimeter Plane

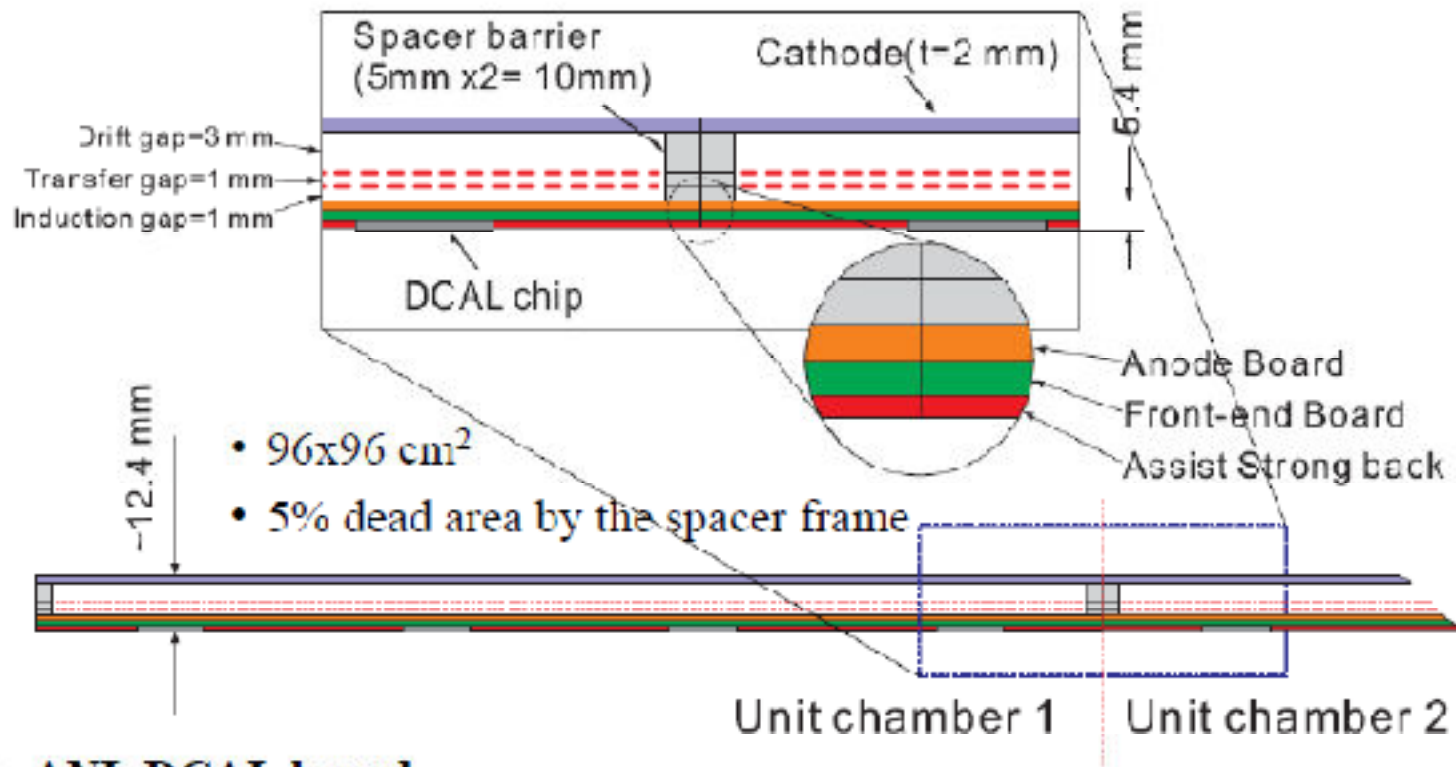

➤ ANL DCAL board

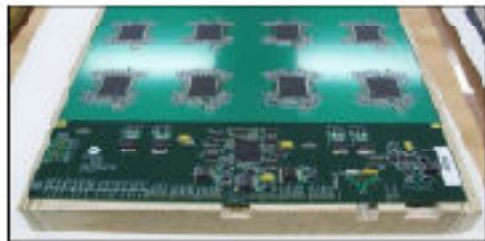

Pad board: 320x480x1.5 mm³

Front-end board: 320x555x1.5 mm³

GEM DHCAL Beam Test Plans

- Phase I → Completion of 30cm x 30cm characterization
 - Mid 2010: using one to two planes of 30cm x 30cm double GEM chamber with 64 channel KPiX7
- Phase II → 33cm x 100cm unit chamber characterization
 - Mid 2010 - mid 2011 at MTBF: Using available KPiX chips and DCAL chips
- Phase III → 100cm x 100cm plane GEM DHCAL performances in the CALICE stack
 - Early 2011 - Late 2011 at Fermilab's MTBF or CERN
 - Five 100cm x 100cm planes inserted into existing CALICE calorimeter stack and run with either Si/W or Sci/W ECALs, and RPC planes in the remaining HCAL