



International Linear Collider Workshop 2010

Friendship Hotel, Beijing, China, 26-30 March 2010

# ILC Superconducting Final Doublet and the ATF2 Superconducting Magnet Upgrade (Update)

Brett Parker\*

BNL-SMD

\*For BNL Superconducting Magnet Division and the  
ATF2 Superconducting Magnet Upgrade Collaboration



# ILC R&D Prototype and ATF2 Comparison

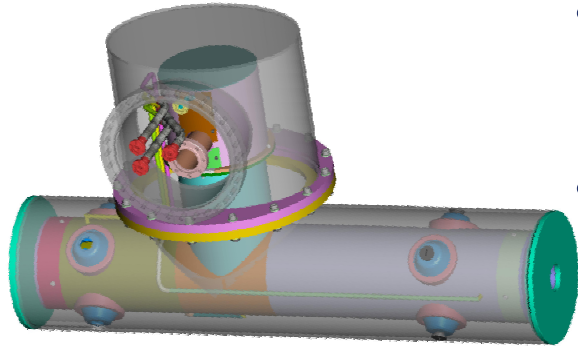

ATF2 Upgrade Magnet  
(concept test with beam)

- Both are compatible with 1.9K testing via an ILC-style Service Cryostat (SC) at BNL.
- ATF2 magnet should be 4.2K tested at BNL with SC and the ATF2 Cryogenic Box before being shipped to KEK.
- The ATF2 magnet can be tested with beam; there is no way to beam test R&D prototype.

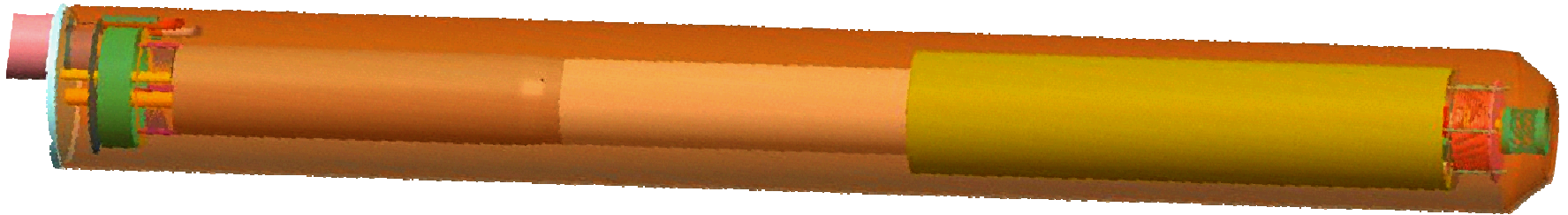

ILC QD0 Full-Length R&D Prototype Magnet Program  
(a full-scale, instrumented, 1.9K ILC SC, systems test)

# ATF2 SUPERCONDUCTING UPGRADE STATUS UPDATE



# ATF2 Upgrade Production/Design Status

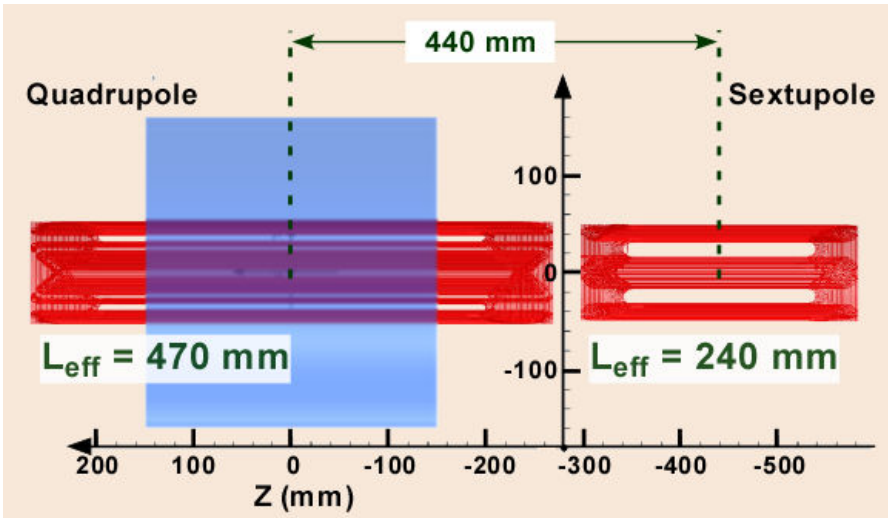

- Main coil winding now complete.
- Measured harmonics are small.
- A first pass cryogenic interface made at '09 face-to-face meeting.
- Magnetic shielding calculations (homework) done; results indicate we can make both Hor./Vert. laser penetrations (through the quad's magnetic shield) at the center of each magnet coil without spoiling their good harmonics and still ensuring sufficiently low B-field at the external geophone locations.

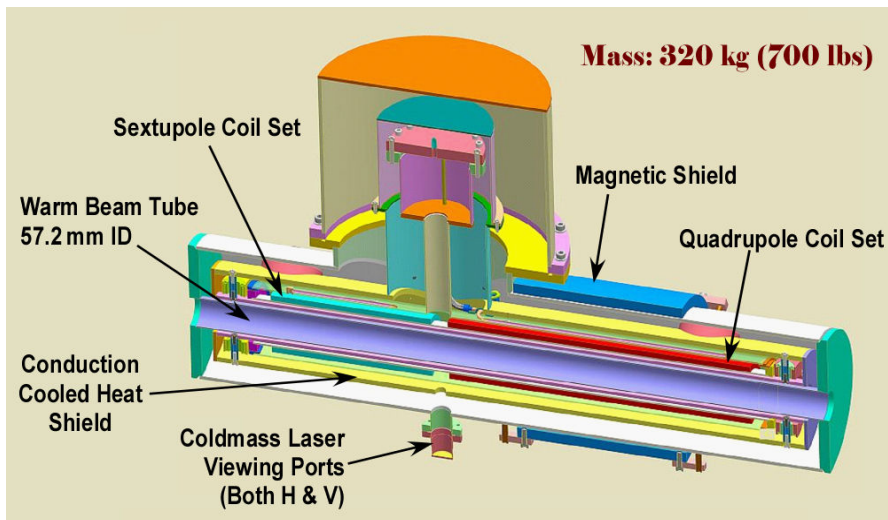



# ATF2 Coil Winding Overview

- Winding of the main quadrupole (six layers) and sextupole (four layers) coils now complete.
- Production measurement results for field harmonics are consistent with our understanding of the requirements for future ATF2 “pushed  $\beta^*$  optics” studies.
- In order to keep to a “2012 delivery schedule,” we do need to start winding corrector layers soon (have resource conflict with QD0 long-coil winding).
- Under the most aggressive delivery schedule, we would want to vertically cold test later this year (also resources).

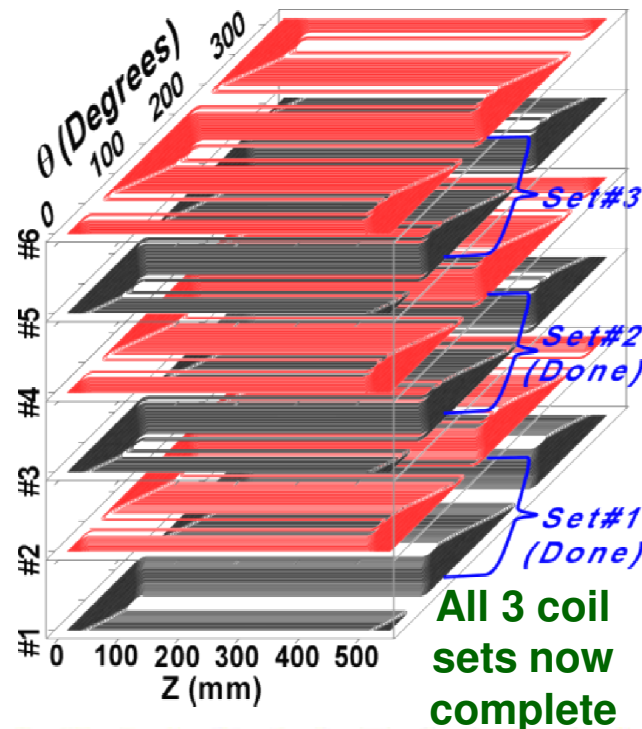
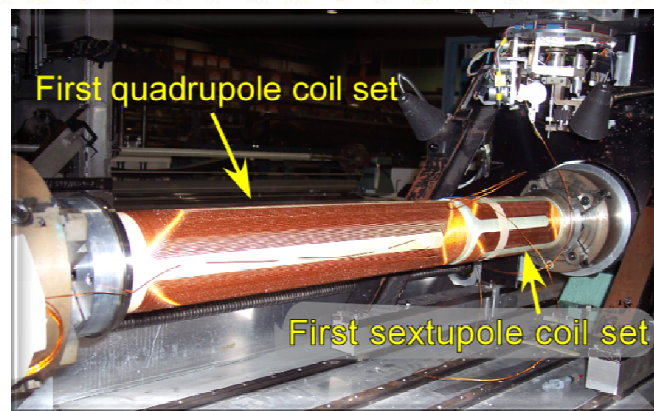



# Summary of Integral Field Quality in ATF2 Magnet

Normal	Quadrupole	Sextupole	Skew	Quadrupole	Sextupole
I.T.F.	26.959	194.00	I.T.F.	26.959	194.00
Fld. Ang. (mr)	-12.5	14.8	Fld. Ang. (mr)	-12.5	14.8
Leff(m)	--	--	Leff(m)	--	--
b1	--	-0.3	a1	--	-8.6
b2	10000.0	--	a2	--	--
b3	1.2	10000.0	a3	-1.2	--
b4	-1.3	0.6	a4	-2.2	-2.0
b5	0.4	-0.8	a5	-0.3	-1.5
b6	0.7	0.1	a6	0.1	-4.2
b7	0.0	0.2	a7	0.2	-0.4
b8	-0.1	0.4	a8	0.1	0.2
b9	0.0	0.4	a9	0.1	0.3
b10	0.0	0.1	a10	-0.2	0.2
b11	0.0	0.5	a11	0.0	0.1
b12	0.0	0.1	a12	0.0	-0.2
b13	0.0	0.0	a13	0.0	-0.1
b14	0.0	-0.1	a14	0.0	0.0
b15	0.0	-0.5	a15	0.0	0.0

Harmonics are in "Units" of  $10^{-4}$  of the main field at 25 mm as seen from the lead ends of respective magnets (yielding opposite sign of field angle in the two magnets). I.T.F for Quadrupole is in T/kA; ITF for Sextupole is in T/m/kA (Integral of B" in sextupole is two times the value reported for the I.T.F).

## ATF2 Coils

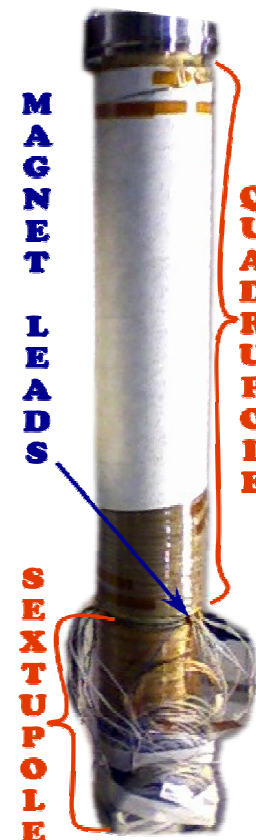



# Laser View Port & Geophone Status

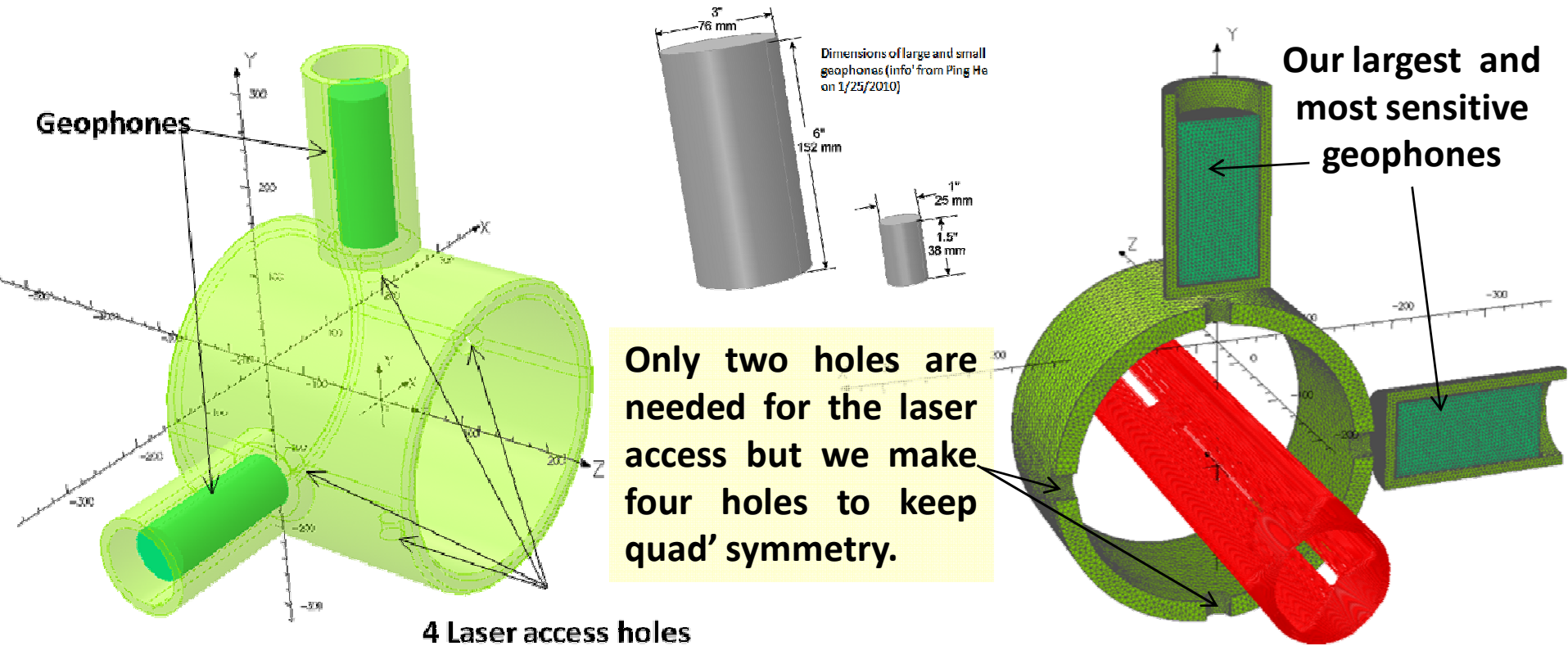

- At  $R_{ref} = 25\text{mm}$ , the harmonics change by less than 0.1 unit.
- External field is low enough, even for our largest geophone.
- Passive shielding still works even with 25 mm ID holes!



# Cryogenics Interface Update

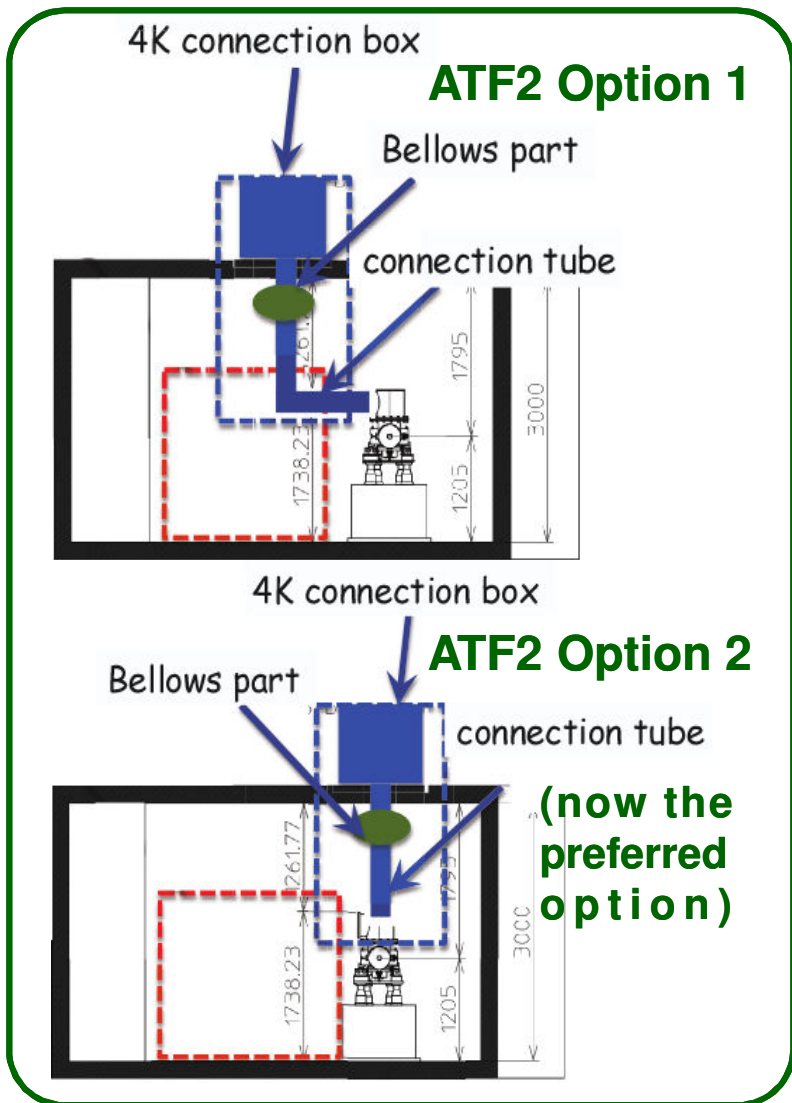

**ATF2 SC FD**  
**face-to-face**  
**meeting at**  
**BNL**

Tuesday 24 November 2009  
from 08:00 to 18:00  
US/Eastern  
at BNL, USA ( 902A Conference Room 63 )  
support: [parker@bnl.gov](mailto:parker@bnl.gov)

Material:

## Our last meeting at BNL

Tuesday 24 November 2009

[top](#)

### 08:00->09:00 Setup and Welcome

Description:

- 1) Time for preparation before start of meeting
- 2) Welcome and Introductions

### 09:00->12:00 Morning Session

09:00	ATF2 Superconducting Upgrade Introduction & Overview (30)	Brett Parker
	( Slides )	
	1) Review work that has already been done. 2) Discuss work needed for the next ATF2 TB review 3) Discuss plan for today's meeting	
09:30	Status of the KEK Cryogenic Design (30)	Nobuhiro Kimura and Takayuki Tomaru
	( Slides )	
10:00	Review and Discussion of the BNL Mechanical Design (1:00) ( Slides )	Andy Marone and Henry Hocker
	Short presentation plus viewing of CAD model	
11:00	Discussion of Laser Access Ports (30)	Brett Parker (David Urner and Paul Coe via webex)
11:30	Discussion of Supports/Stabilization Structure (30) ( Slides )	Brett Parker (Andrea Jeremie and Benoit Bolzon via webex)

Face-to-face meeting at BNL was very productive; do we need to schedule a new meeting? At KEK?





# A Superconducting Magnet Upgrade of the ATF2 Final Focus: Collaboration List

Michael Anerella, John Escallier, Ping He, Animesh Jain, Andrew Marone, Brett Parker, Peter Wanderer, and Kuo-Chen Wu (BNL), Rogelio Tomas Garcia, Claude Hauviller, Eduardo Marin Lacoma and Frank Zimmermann (CERN), Nobuhiro Kimura, Kiyoshi Kubo, Tatsuya Kume, Shigeru Kuroda, Toshiyuki Okugi, Junji Urakawa, Toshiaki Tauchi, Nobuhiro Terunuma, Takayuki Tomaru, Kiyosumi Tsuchiya and Akira Yamamoto (KEK), Philip Bambade (LAL), Andrea Jeremie and Benoit Bolzon (LAPP), Paul Coe and David Urner (Oxford University), Andrei Seryi, Cherrill Spencer, and Glen White (SLAC)

Co-Spokesmen: Brett Parker (BNL), Andrei Seryi (SLAC) and Toshiaki Tauchi (KEK)



# ATF2 Upgrade Current Status

- Recently the ATF2 Superconducting Magnet Upgrade Collaboration has grown considerably\* and significant progress has been made (esp. during the 2009 face-to-face meeting).

\*Please contact me if you want to join the collaboration (or possibly just the mailing list).

- Never-the-less BNL's ATF2 effort is paused (waiting to wind corrector layers) so that we can concentrate more fully on the QD0 R&D Prototype.
- The Service Cryostat design and production work supports both ATF2 and the R&D prototype.
- We do look for feedback re. Japanese funding projections for upgrade cryogenic infrastructure.

# ILC QD0 R&D PROTOTYPE (LONG COIL) STATUS UPDATE

# ILC QD0 R&D Prototype

## Long Coil Winding Challenges

- We did not adequately control the coil support tube position (even with orthogonal machine-controlled rolling supports). Our first R&D coils had substantial harmonic errors.
- We have therefore decided to go back to using a few fixed, rigid supports and have made modifications (shown here) to the ATF2

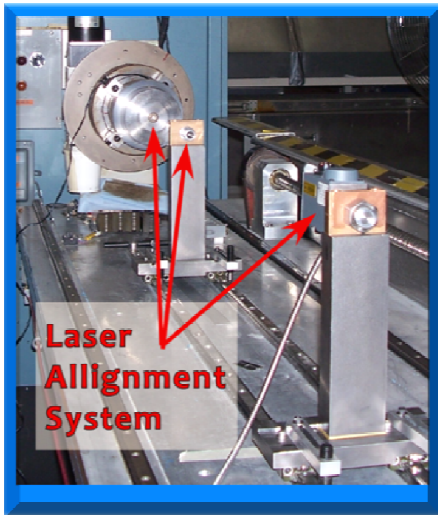

short coil winding machine.

- We extended the machine & carefully positioned fixed supports between the coils.
- The 2.2 m long QD0 R&D coil will be wound in two sections on a common tube.

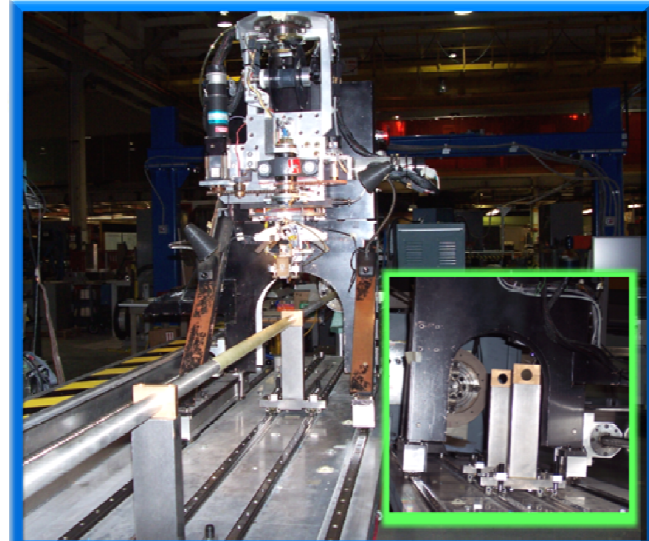



# Service Cryostat & Other ILC Activities at BNL

## Service Cryostat Under Construction at BNL

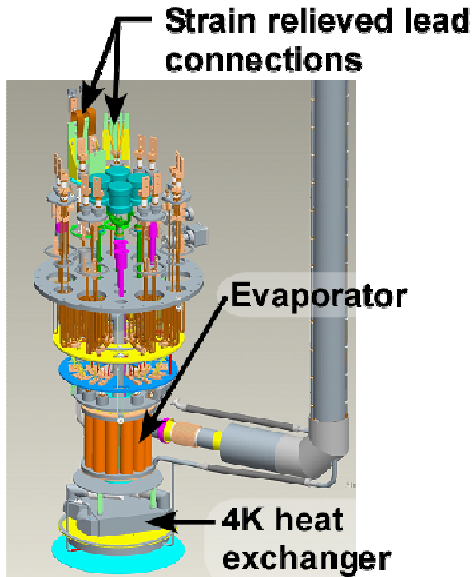

**Develop option that allows for ILC-like 1.9K tests at BNL and 4.2K operation at ATF2 (KEK) with cryo-coolers.**

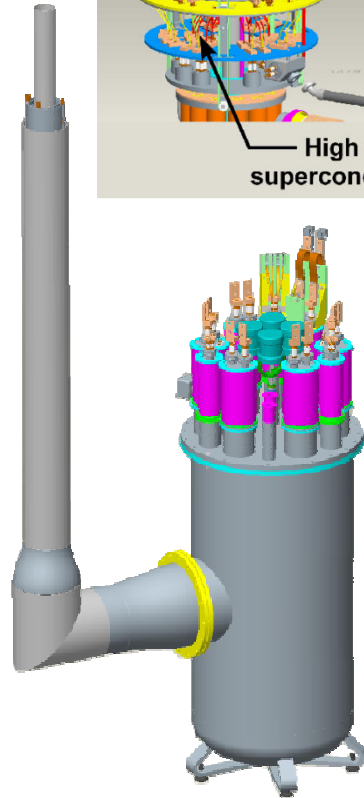
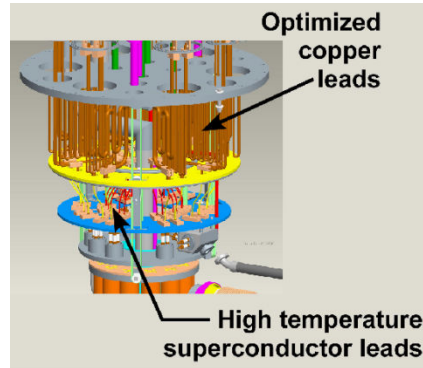

- SC design features for ATF2 mode nearly finished.
- Detailed drawings for SC and QD0 now underway.
- SC and QD0 long lead time items are identified (initiate critical orders).
- For MDI, look to restart work on QF1 cryostat and the cryogenic transfer lines.
- Demonstrate ILC-like FF magnet system production and operation.
- Common ILC/CLIC work.

# BACKUP SLIDE



# Summary of Integral Field Quality in ATF2 Magnet

- Because field harmonics change rapidly with reference radius, we recalculated the measurements for  $R_{ref} = 10$  mm (for easy comparison to the present ATF2 magnets).
- The poorest quad harmonics (b3,a3), are now only **49. parts per million**.
- The areas highlighted in blue are all **smaller than 200 parts per billion**.

	Quadrupole	Sextupole
I.T.F.	26.959	194.00
Fld. Ang. (mr)	-12.5	14.8
Leff(m)	--	--
b1	--	-1.6
b2	10000.0	--
b3	0.49	10000.0
b4	-0.20	0.3
b5	0.025	-0.133
b6	0.018	0.006
b7	0.000	0.005
b8	0.000	0.004
b9	0.000	0.002
b10	0.000	0.000
b11	0.000	0.000
b12	0.000	0.000
b13	0.000	0.000
b14	0.000	0.000
b15	0.000	0.000
a1	--	-53.8
a2	--	--
a3	-0.49	--
a4	-0.35	-0.79
a5	-0.016	-0.238
a6	0.001	-0.270
a7	0.002	-0.010
a8	0.001	0.002
a9	0.000	0.001
a10	0.000	0.000
a11	0.000	0.000
a12	0.000	0.000
a13	0.000	0.000
a14	0.000	0.000
a15	0.000	0.000

## Summary of Integral Field Quality in ATF2 Magnet (QH0LC5)

Harmonics are in "Units" of  $10^{-4}$  of the main field at 10 mm radius

Harmonics reported are as seen from the lead ends of respective magnets

(This also accounts for the opposite sign of field angle in the two magnets)

I.T.F for Quadrupole is in T/kA; ITF for Sextupole is in T/m/kA

(Integral of B" in sextupole is two times the value reported for the I.T.F)