

NML - RF Unit Test Facility at Fermilab

Bob Kephart

March, 2010

(Acknowledgements: Jerry Leibfritz and Elvin Harms)

NML Project Overview



- **Overall Goals**
 - **Build an RF Unit Test Facility at the New Muon Lab (NML)**
 - ILC RF Unit = 3 cryomodules
 - 10-MW RF system
 - Beam with ILC parameters (3.2 nC/bunch @3 MHz, Up to 3000 bunches @ 5Hz, 300- μ m rms bunch length)
 - **Build Test facilities for Project-X cryomodules**
- **Phase-1 (FY07 – FY10)**
 - **Prepare facility for testing first cryomodule (CM1) without beam**
 - Infrastructure, RF power, cryogenics (Tevatron satellite refrigerators #1 & #2)
 - Install first cryomodule (CM1) and Capture Cavity-2 (CC2), cooldown, and RF test

NML Project Overview



- **Phase-2 (FY10 - FY11)**
 - **Prepare for first beam**
 - Civil construction to expand facility (capability for 2 RF units)
 - Move parts from FNPL photo-injector to NML
 - Install new gun, injector, test beamlines, beam dump
 - Install/test second cryomodule (CM2)

- **Phase-3 (FY11 – FY14)**
 - **Complete RF Unit**
 - Upgrade RF system to 10 MW, install third cryomodule (CM3)
 - Commission new Cryogenic Plant
 - Operate full RF Unit with beam
 - Begin installation of 2nd RF Unit

Phase-1 Layout of NML

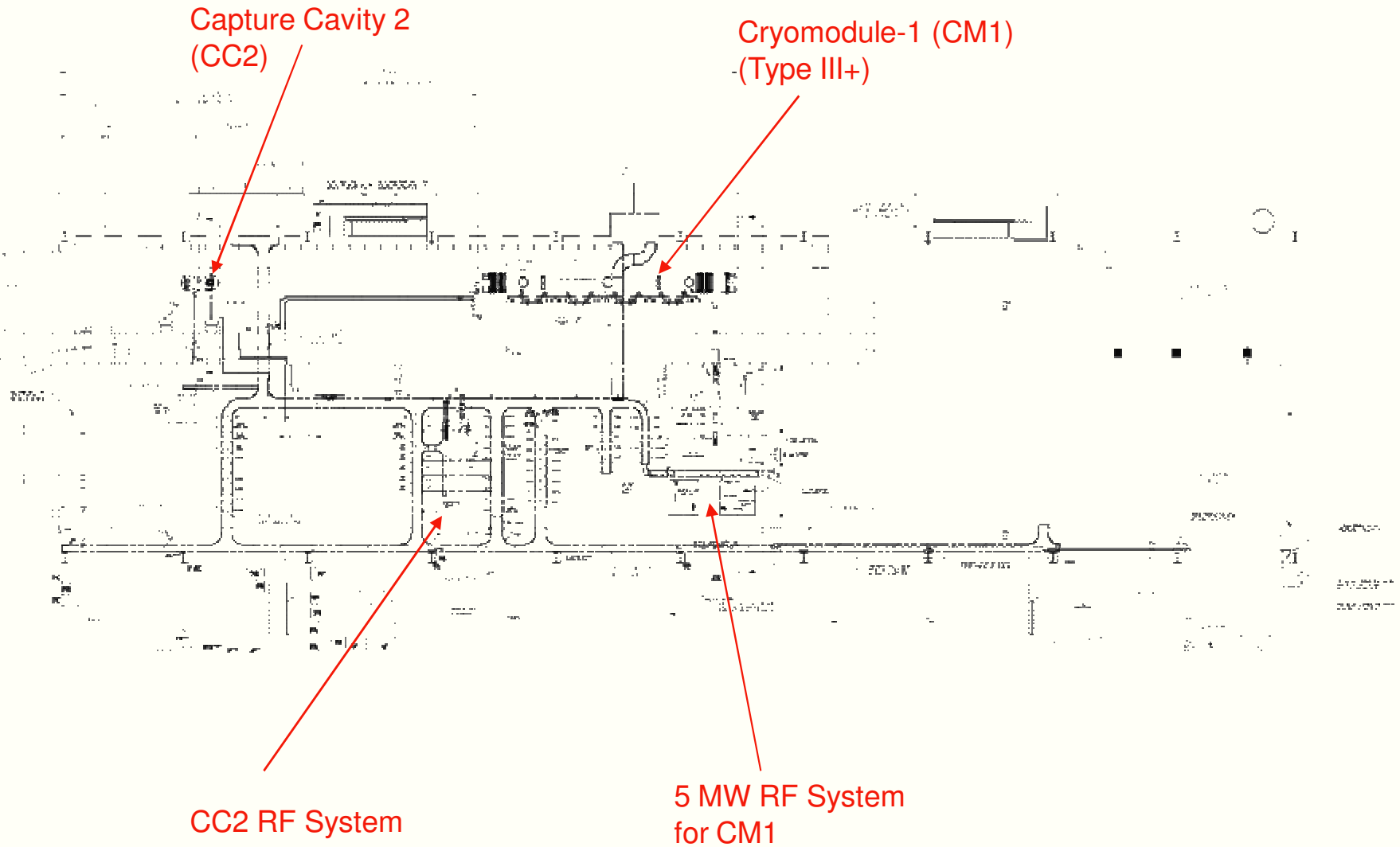

Phase 2/3 Layout of NML Building

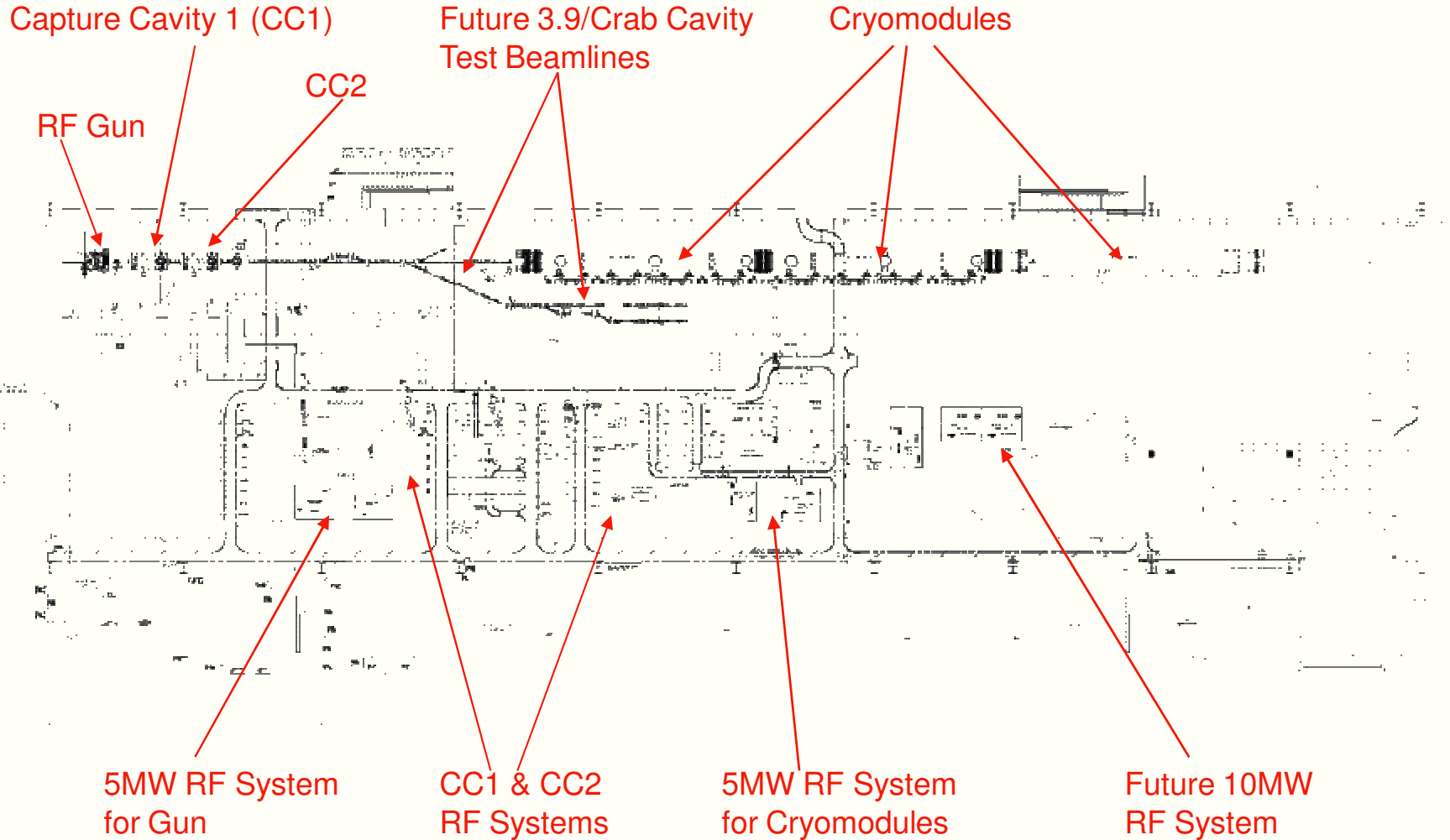

Expansion of NML Facility



Fermilab

New Cryoplant & CM Test Facility

(300 W Cryogenic Plant, Cryomodule Test Stands, 10 MW RF Test Area)

Funded by ARRA

New Underground Tunnel Expansion

(Space for 6 Cryomodules (2 RF Units), AARD Test Beam Lines)

Existing NML Building

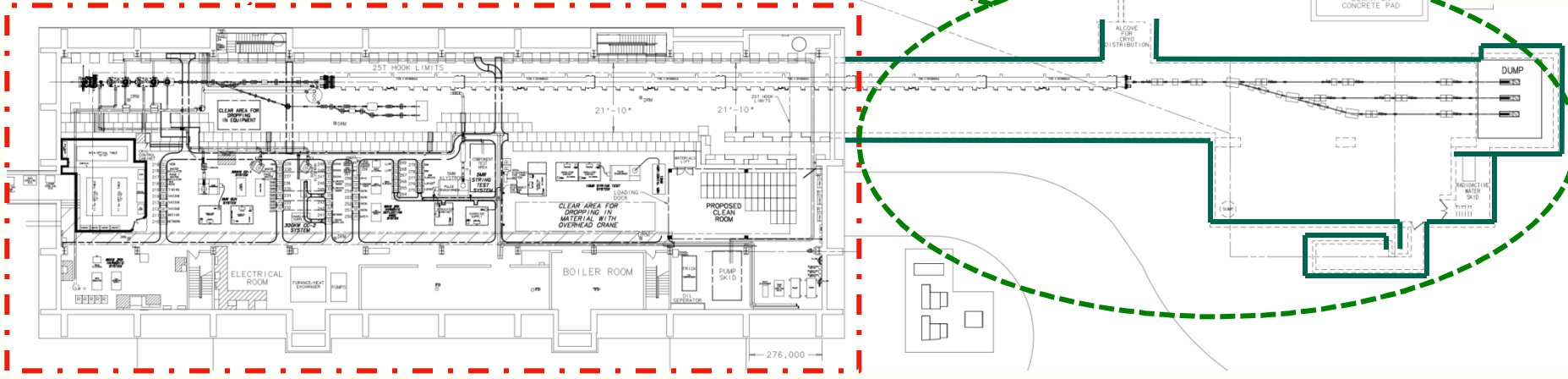
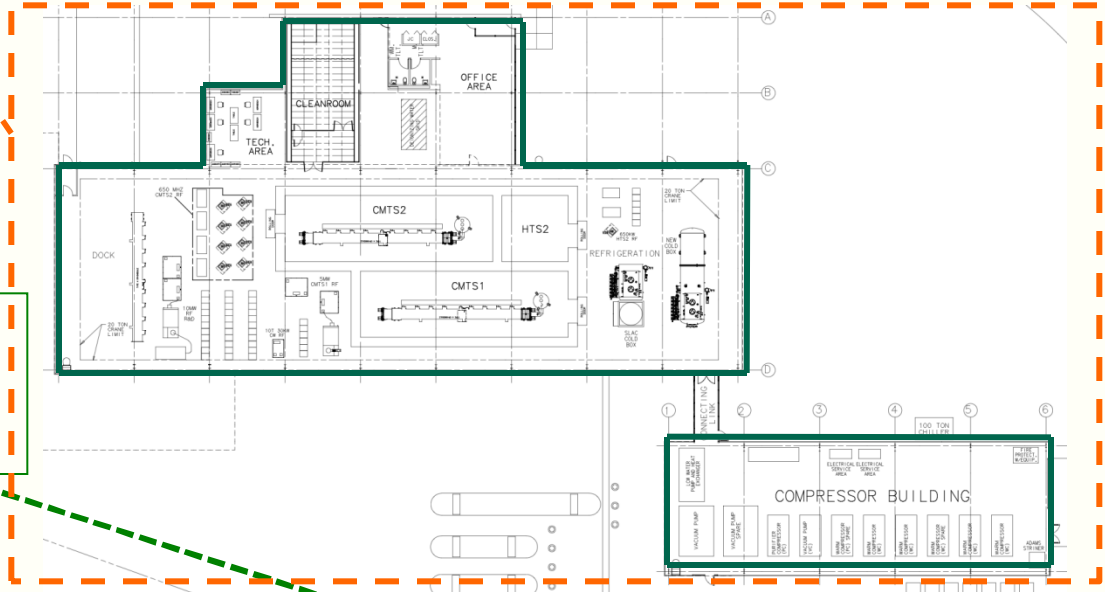

March, 2010

LCWS10

Future NML Complex



NML Expansion



Fermilab

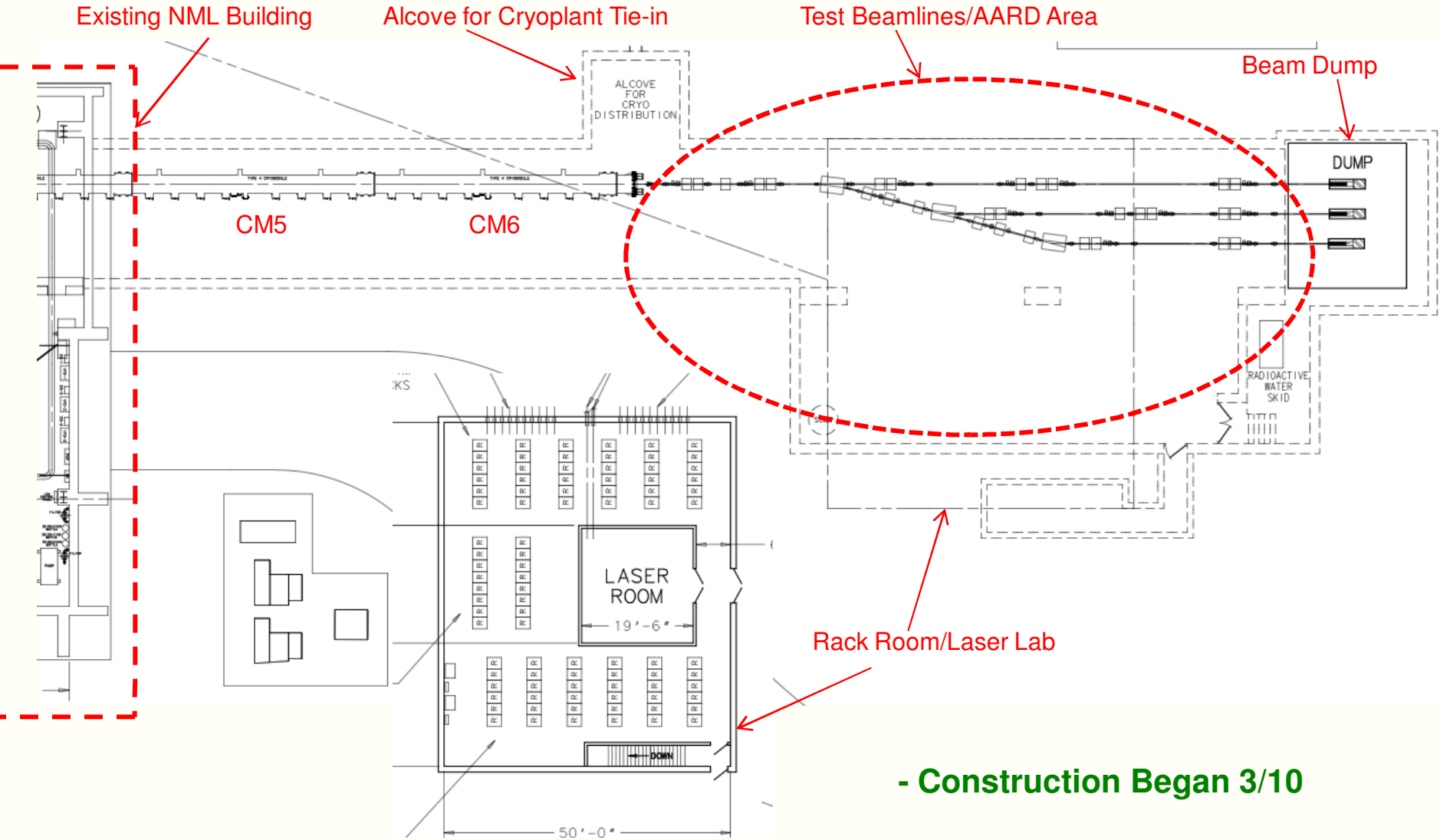

- Construction Began 3/10

NML Technical Progress



March, 2010

LCWS 10

NML Infrastructure (FY07-08)



- **Completed Removal of Chicago Cyclotron Magnet**
- **Prepared Building Infrastructure**
 - AC power, network cabling, piping, cable tray, air ducts
 - Cleaned out building, epoxy coated floor, alignment network
 - Cave for Phase-1 (~3/4 of full cave), electrical racks
 - Reused existing equipment (tray, racks, piping, shield blocks, gas storage tanks, cryo heat exchangers & refrigerator components)



NML During Removal of Chicago Cyclotron Magnet (CCM) (September, 2006)



NML Facility after CCM Removal and Floor Painting (February, 2007)

Recent Picture of NML Facility



March, 2010

LCWS10

View From North



March, 2010

LCWS 10

NML Expansion Construction



Loading Dock Demolition



Erection of Laser Deck



Cryo Pipe Installation

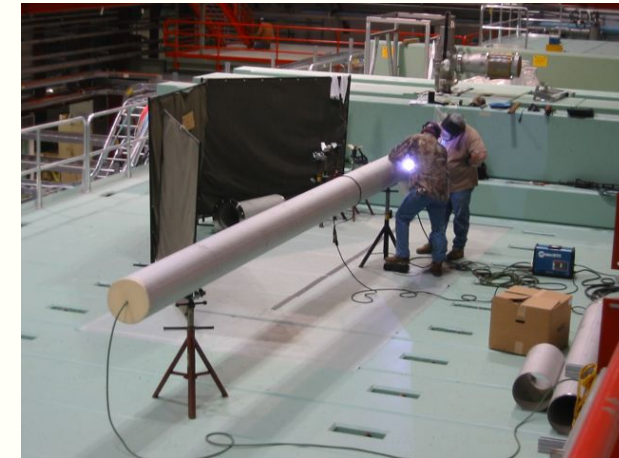

NML Cryogenic System



- **NML Cryogenic System Plan**
 - Start with two 625 W (4K) Tevatron satellite Refrigerators and large vacuum pump (~ 100 W at 1.8 K)
 - Move 1500 W (4 K) BABAR refrigerator from SLAC
 - Add new 300 W (1.8 K) refrigerator
- **Status**
 - Installed Refrigerator room & helium storage tanks
 - Tevatron Satellite Refrigerator #1 operational - 8/07
 - Tevatron Satellite Refrigerator #2 installed – 7/09
 - Distribution system
 - **Feedbox, Feed Cap & End Cap installed**
 - Vacuum pump and Frick compressor
 - Capture Cavity-2 (CC2) Cooled to 2K – 10/09
 - Cryomodule-1 (CM1) Cool down to 2K – Spring, 2010

NML Cryogenic System

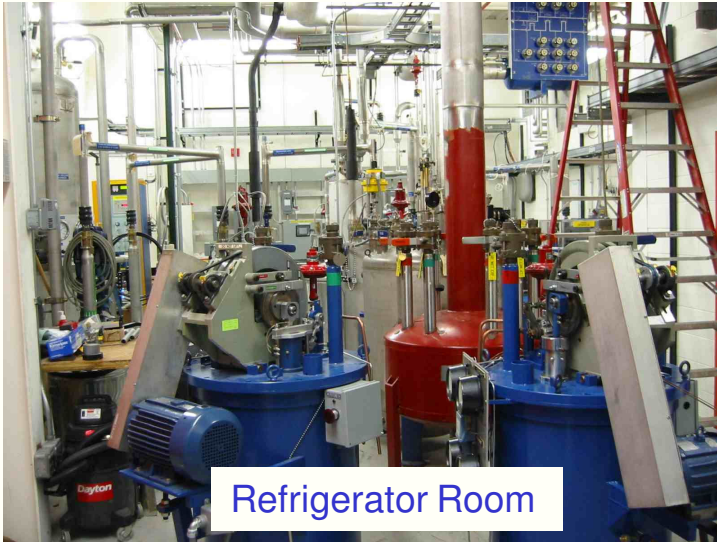

Refrigerator Room



Feedbox/Feedcap



Satellite Refrigerators



Cryo Vacuum Pump

NML RF Systems

- **RF System**
 - **5 MW for CM1**
 - Commissioning underway
 - **300 KW for CC2**
 - Fully Operational
 - **Distribution**
 - CM1 distribution from SLAC (in-house)



CM1 moving to NML



March, 2010

LCWS10

NML Accelerator

- **Injector**
 - Detailed Lattice designed
 - New gun system being installed
 - Collaboration with DESY, KEK & INFN
 - CC2 (single 9-cell cavity) operational - 10/09
- **Accelerator**
 - CM1 installed, aligned, and under vacuum
- **Test Beamline**
 - Beamline layout complete
 - Beam Absorber analysis complete



CC2 Operation At NML



- **Moved from MDB to NML – 2/09**
- **Installation complete (vacuum, cryo., alignment) – 6/09**
- **First warm RF powering – 6/09**
- **Coupler conditioning complete – 7/09**
- **CC2 operated at 2 Kelvin – 10/09**
- **24 MV/m gradient (limited by Coupler PM Tube trips) – 2/10**
 - **Similar to performance in MDB**
- **Current Plans**
 - **Operate at 4.5 K until construction allows resumption of 2K ops**
 - **Studies of Low Level RF system and tuner, microphonics and Lorentz Force Detuning Compensation**
 - **Resume 2K operation after construction, prior to CM1 cooldown**

CC2 Operations at NML



- **Regulated operation**
 - LLRF feedback and feedforward enabled
 - 1.3 ms pulse width
 - 5 Hz
 - 20 MV/m
 - Limitation is Coupler

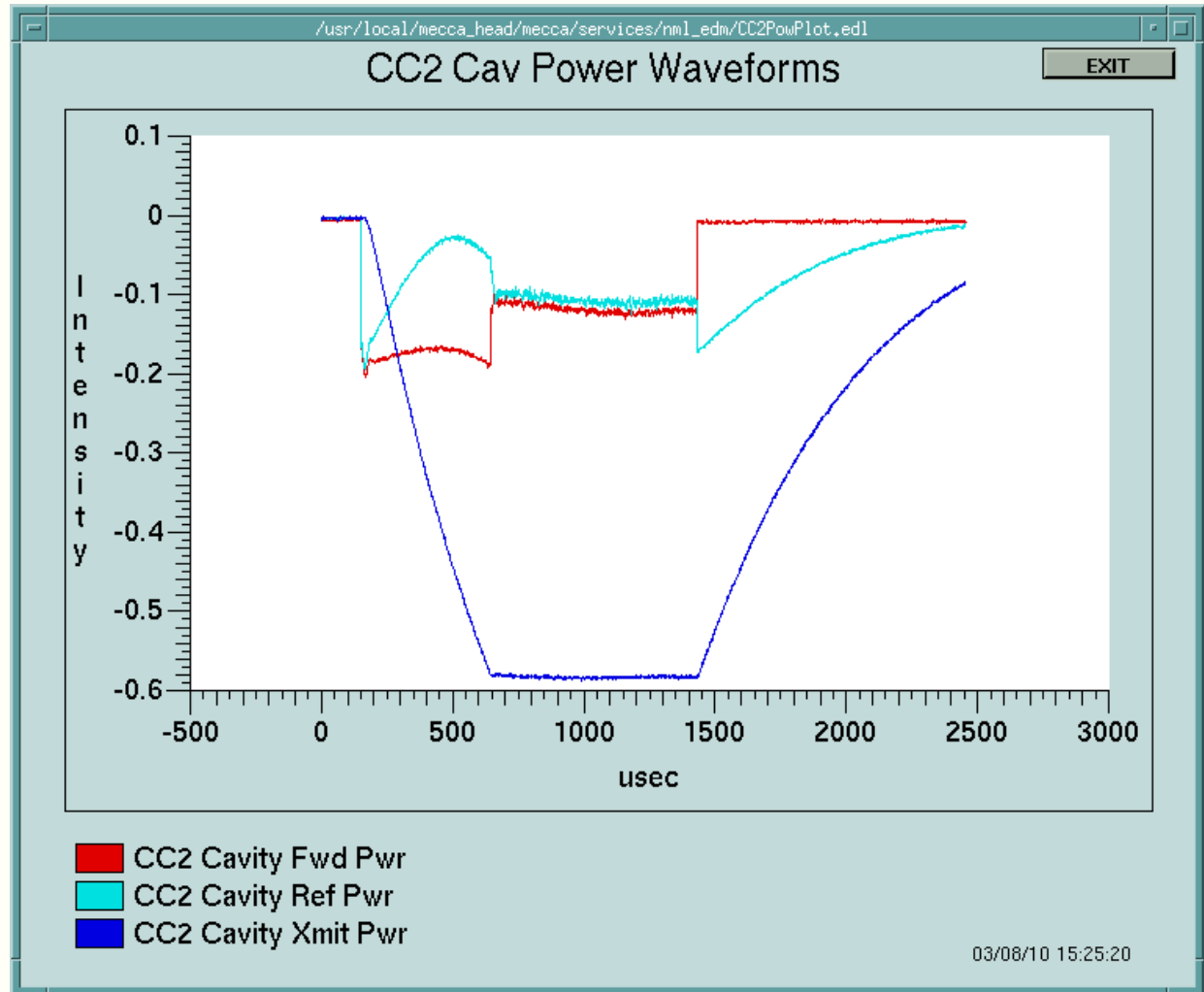

CC2 Performance at NML



- Peak gradient - 24 MV/m
- Limited by Coupler activity
- $Q_L = 2.92 \times 10^6$
- Similar performance as at MDB previously

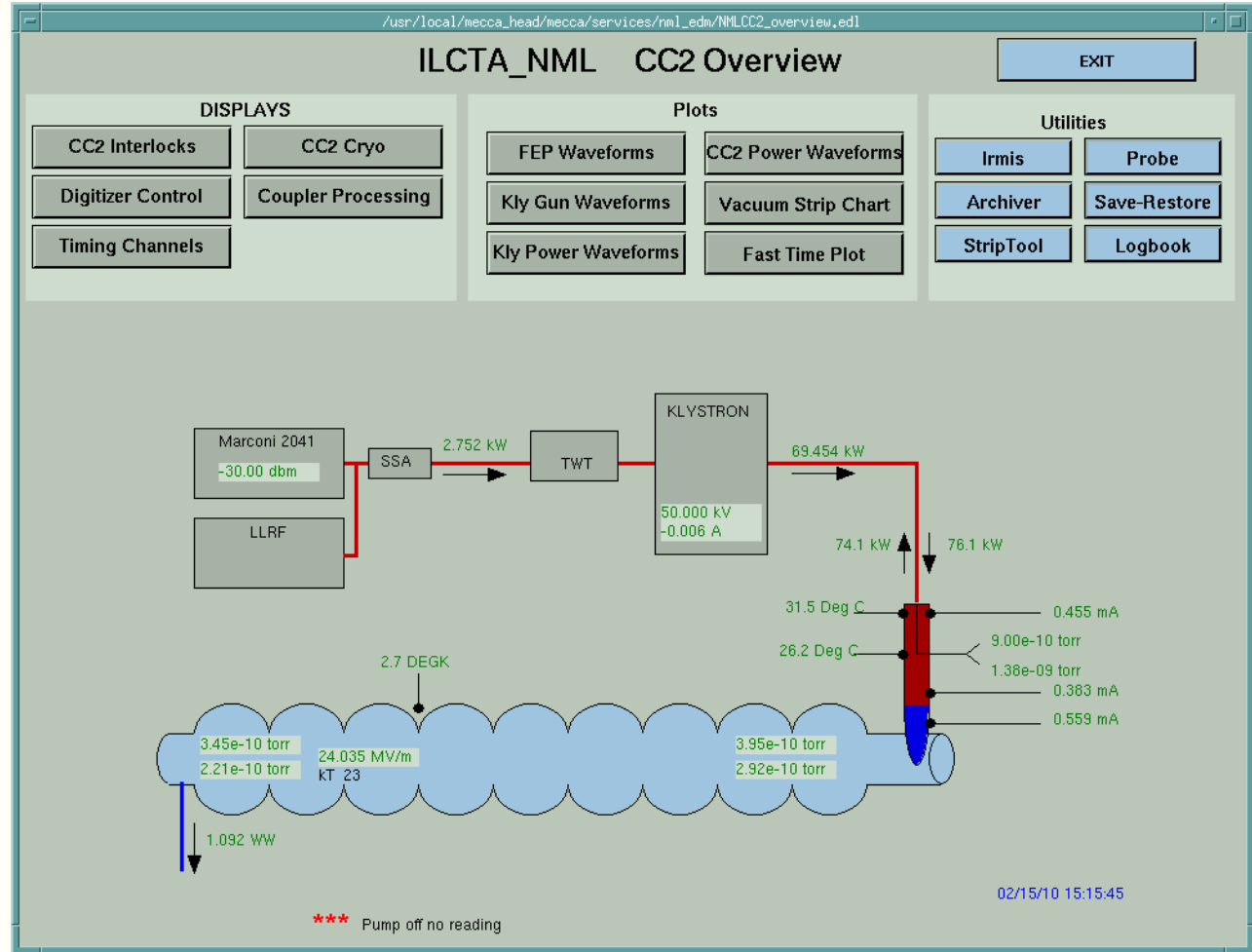

CC2 Performance at NML



- Onset of field emission ~ 16 MV/m
- Similar threshold for dark current
- Largest amplitude at Coupler end

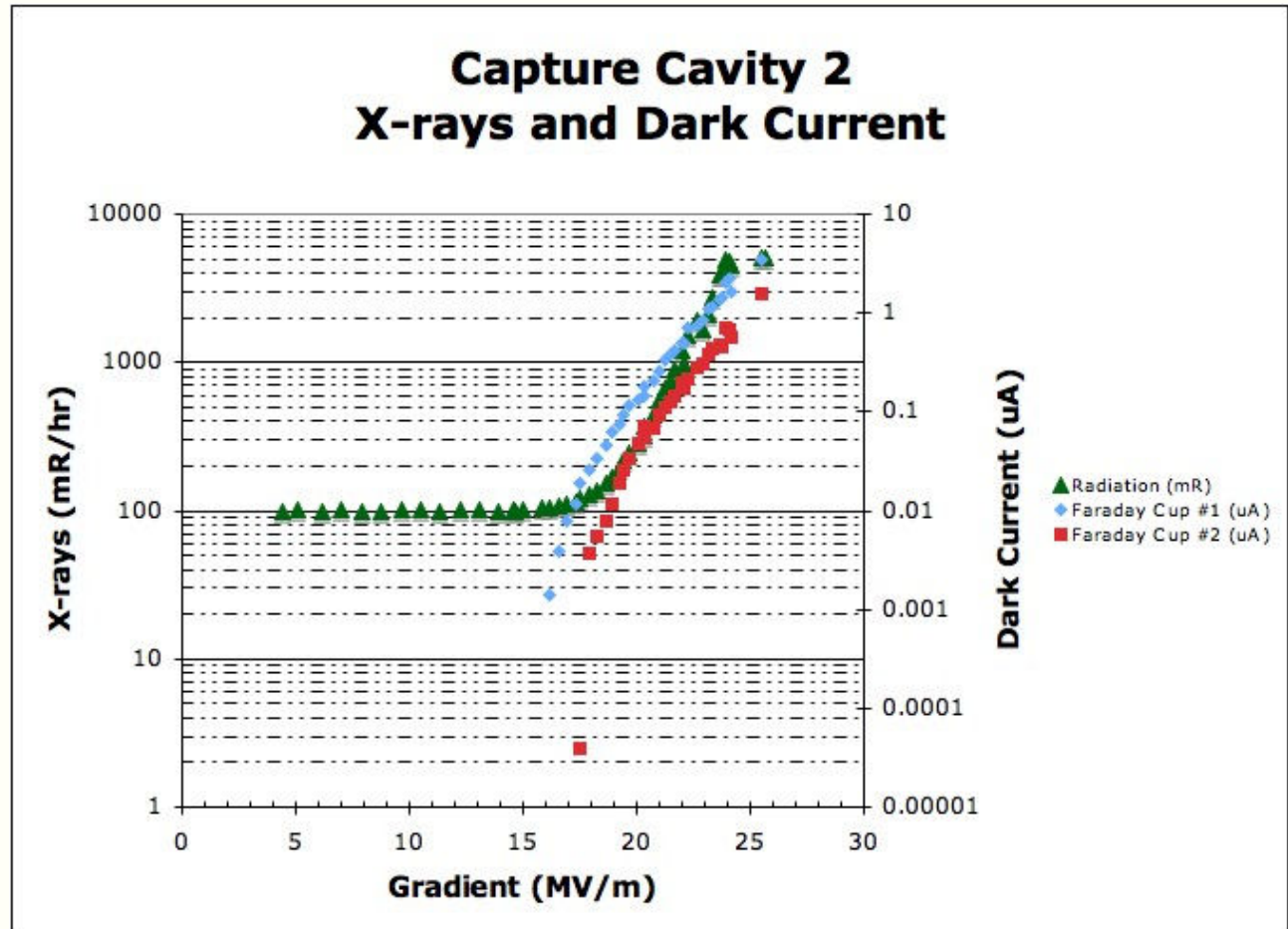

CM1 Test Plan



- Virtually identical to DESY run plan for XFEL modules (*courtesy of Dennis Kostin*) and Fermilab experience at HTS and CC2
- **TEST PROCEDURE:**
 - 1. RF Cable Calibration
 - 2. Technical Interlock / Sensor checkout
 - 3. RF source / Waveguides / LLRF
 - 4. Warm Input RF Coupler Conditioning
 - 5. Cooldown to 2K
 - 6. Cavity Spectra measurements
 - 7. Cavity Tuners Test and Tuning
 - 8. Coupler Q_{load} measurement
 - 9. Set Cavities On Resonance
 - 10. Cold Input RF Coupler and Cavity Conditioning
 - 11. Module Performance Measurement
 - 12. Single Cavity Measurements
 - 13. Cryo system performance test (if needed).
- Expect 2-3 weeks to complete run plan

CM1 Test Plan



- Our first goal is to understand the performance of cavities in CM1 compared to HTS tests at DESY
 - We want to verify our assembly techniques in CAF
- Note that the dressed cavities provided by DESY for CM1 are NOT 35 MV/M cavities
 - We do not expect to meet the S1 goal of 31.5 MV/M
 - Average of Chechia tests is 23.5 MV/M
 - Anything close to this number will be a great success

	Z89	AC75	AC 73	Z106	Z107	z91	z91	S33
Eacc max [MV/m]	23.5	22.5	30.6	33.5	36.5	31.1	28.5	26.6
Fe onset [MV/m]	> 23,5	>22,5	25.83	21	30.6	25.6	20	19.28
Eacc @ 1Exp-2 mGy/min	> 23,5	>22,5	28.6	27	32.4	29.7	24.41	23,48

- It would be useful to understand what other tests might be useful for ILC with CM1

NML Auxiliary Systems



- **Vacuum System**
 - Low-particulate vacuum cart built and tested
 - Leak detectors, RGA's, pumps, gauges, controls
 - (4) portable cleanrooms built (capable of achieving Class-10)
 - CM1 cavity string, and coupler systems under vacuum (10^{-9} Torr)
- **Water Cooling System**
 - System design complete
 - New pumps and heat exchanger installed
 - Temporary skid (for Phase-1) operational
- **Safety Systems**
 - Radiation, ODH, Interlock, and Safety Assessment documentation being prepared

NML CM1 Vacuum Work

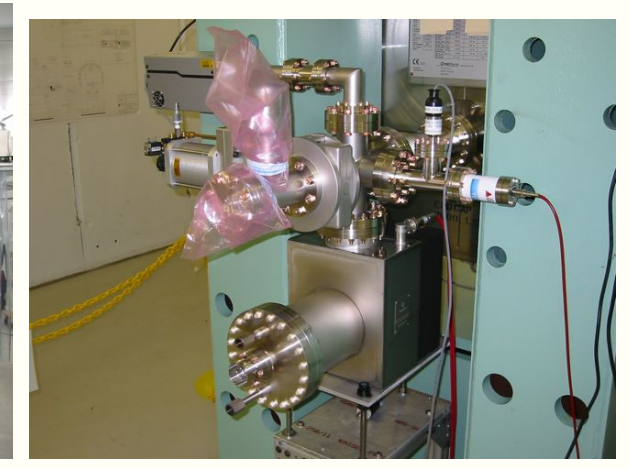

NML Auxiliary Systems

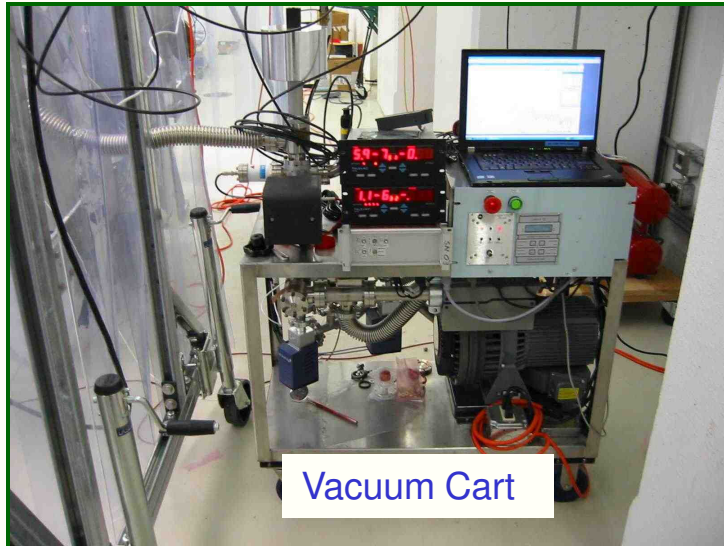

NML Controls/Instrumentation

- **Controls**
 - Control Room finished and operational
 - Wireless network installed throughout building
- **Instrumentation**
 - Wire Position Monitors for CM1 tested and installed in Endcaps
 - Faraday Cups assembled
 - RF protection/interlock system complete



Before



After

NML Schedule/Milestones



- **Phase-1 Cryogenic System Operational** (Aug. 2007)
- **Delivery of First Cryomodule to NML** (Aug. 2008)
- **Begin Civil Construction of NML Expansion** (March 2010)

- **First Cryomodule Ready for Cooldown** (Spring 2010)
- **Cold RF Testing of First Cryomodule** (Summer 2010)
- **Start Construction of CMTF Building** (Fall 2010)
- **Delivery of 2nd Cryomodule to NML (S1)** (2010)
- **Install Injector & Test Beam Lines** (2011)
- **First Beam** (2012)
- **New Cryoplant Installation/Operation** (2013-14)
- **RF unit test with beam** (2014)

Integrated SRF Plan (Cryomodules)

U.S. Fiscal Year	2008	FY09	FY10	FY11	FY12	FY13	FY14	FY15
1.3 GHz								
CM1 (Type III+)		Omnibus Delay	CM Ass'y	Install CM	CM Test			
CM2 (Type III+)		Omnibus Delay	Process & VTS/Dress/HTS	CM Ass'y	sw ap			
CM3 (Type IV)		Omnibus Delay	Design	Order Cav & CM Parts		2/3 CM		
CM4 (Type IV)						sw ap		
CM5 (Type IV)						sw ap		
CM6 (Type IV+) CW Design					Design CM 1.3 GHz CW			Install in CMTF
NML Extension Building		Design	Construction					
NML Beam					Move injector/install beam components	Beam Available to RF Unit test except during installation periods (contingent upon cryogenic load/capacity)		
CMTF Building			Design	Construction				
650 MHz								
Single Cell Design & Prototype								
Five Cell Design & Prototype								
CM650 1				Design	Order 650 Cav & CM Parts	Process & VTS/Dress/HTS	650 CM Ass'y	
325 MHz								
SSR0/SSR2 Design & Prototype				Design (RF & Mechanical) all varieties of Spoke Reonators	Prototype (as required)	Process & Test (as required)		
SSR1 Cavities in Fabrication (14)				Procurement (already in progress)	Process & VTS/Dress/HTS			
CM325 1				Design	Procure 325 CM Parts	325 CM Ass'y		

Design	Procure	Process & VTS Dress & HTS	Assemble	Install	Commission & Operate
--------	---------	---------------------------	----------	---------	----------------------

Conclusions



- **RF unit test facility at NML is a new large facility under construction at FNAL in support of ILC and Project X goals**
 - **Delayed by Omnibus bill more than a year**
 - **ILC/SRF funding has been restored**
 - **ARRA funds are a huge boost**
- **NML Cryogenic and RF Operations have begun**
 - **Tests of CCII and CM1 this year**
- **Several opportunities to meet ILC S1 goal over next couple of years**
- **Full test of ILC RF unit (S2 goal) by 2014**