

Plug compatibility Document

ILC10 cavity integration session

H. Hayano

Memo on “Plug Compatibility”
was issued on 01/13/2009
by project managers.

http://ilc-edmsdirect.desy.de/ilc-edmsdirect/file.jsp?edmsid=*865055

This will be one of the basement
of TDR document,
so, it is important!

Marc ROSS
Nick WALKER
Akira YAMAMOTO

27.12.08

Foreword

In the following document, we (the Project Managers) would like attempt to describe our current and evolving philosophy behind plug compatibility. It is not intended as a consensus document; our intention here is to clarify as best we can our ideas, and where possible to address some of the questions that have been brought to our attention. The focus is on the conceptual aspects of plug compatibility (i.e. the rationale) rather than the technical specifications themselves (the engineering solution); the latter requires a document in its own right. The document cannot be (nor is it intended to be) a definitive document describing all aspects of plug compatibility: It should rather be treated as a proposal from the Project Managers for discussion by the global R&D community.

Introduction

When discussing plug compatibility, it is convenient to separate it into two aspects:

- the *rationale* behind adopting plug compatibility, its impact on the Technical Design Phase goals and deliverables, and its possible role in the various project phases beyond the TD phase – approval process, construction phase, operations;
- the *technical and engineering aspects of achieving a modular plug-compatible design*, via the identification of agreed-upon interfaces, specifications and requirements.

Since the concept of “plug compatible” design was first proposed for the SCRF cryomodule in 2007, the focus of attention has been on the *technical and engineering aspects*. Over the year, substantial progress has been made in defining the technical aspects of achieving modularity in sub-component design, by identifying and specifying well-defined engineering interfaces and specifications. For reference, and to show the progress we have made, we have included current status of the technical discussions as Appendix I. The remainder of this document will focus on the first bullet point, namely the *rationale*.

contents;

Forward

1. Introduction
2. Plug Compatibility in the R&D phase (2012)
3. Plug Compatibility during the construction phase
4. Plug Compatibility after project construction
5. Plug Compatibility after an extended R&D phase (post TDR, 2012)
6. Current R&D plan Milestones related to Plug Compatibility
7. Comments, Discussion and Identified issues



Appendix I: Plug Compatibility Interface Definitions for SCRF cryomodule

Appendix II: Mass production models

Plug-compatibility for the ILC-SCRF Cryomodule

Cavity

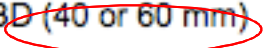
Cavity	Plug-compatibility Standard	Can be flexible - R&D remains	Alternate designs: need to be fitted to standard
Material		large/fine grain	
Shape		TESLA/LL/RE	
Main-body length	1,247.4 mm		
Interconnect length	78.6 mm		
Support bearing-lug spacing	750 mm (+/- 375)		
Beam pipe dia.	78 mm		(80 mm)
Beam pipe flange	NW 78		(conversion through interconnect -region acceptable)
Beam pipe seal	Diamond Hex Seal,		(Helicoflex)
Jacket/cone	NbTi - Ti		Nb/Sus-SUS
He-vessel OD	<= 240 mm		
Tuner type		Blade / slide-jack	

Tuner location	Middle between bearing lugs		
Tuner slow	Control/wiring spec.		
Tuner fast (piezo)	Control/wiring spec.		
Mag. shield		Inside / outside	
Coupler position	e-: downstream-end e+: upstream end		
Coupler Tunability	Tunable		
Diameter (cold)	TBD 		
(warm)	TBD 		
High pr. code	TBD 		
Design pressure	2 bar (delta-P)		
Material	Nb, SUS	NbTi, Ti,	

Cryomodule

Cryomodule	Plug-compatible	Flexible	Note
Vacuum Vessel			
Material	Carbon steel		
Inn. diameter	946.2 mm		
Slot length	12,680 mm		
Length (w/o bellow)	11,830 mm		
He jacket of cavity			
Material	nopefully SUS)	(currently, Ti/SUS)	
Outer diameter	<= 240 mm		
Cavity/coupler slot L.	1326 mm		
Cav. Vertical position	Mid-plane		
Cav. Support-lug pitch.	750 mm		
T-operation	2 K		
Inner-shield (5K)	Envelope to be fixed	To be simplified	
Outer-shield(40-60 K)	40 – 60 K		
Cryogen	GHe		
Heat load at 2 K	< 11.7 / < 11.2 W		
Magnet			
Field Gradient Int.	36 T		
Aperture	78 mm		
Effective length	600 mm		
T-operation	2 K		
Type of winding		Cos-theta or Block	

General Specification for the ILC-SCRF Cryomodule

The plug-compatible conditions described above are based on the following general specification discussed in RDR with minor updates in TD-phase R&D plan.

Component	Category	Item	Specification	Note
Cavity	RF properties	Frequency	1.3 GHz	
		No. Cells	9 cells	
		Gradient (VT)	35 MV/m	
		Gradient (Beam)	31.5 MV/m	
		Q0 at 31.5 MV/m	1.0 E10	
	Cryogenic prop.	Temperature	2.0 K	
	Mechanical prop.	Pressure	2 Bar	
		Length	1247 mm	Tesla-short
		Aperture	TBD	
		Alignment	0.3 mm	

		acc.		
	Tuner (slow)	Lorentz detuning	1.00 kHz	@ 35 MV/m
		Tuning range	> 600 kHz	
		Magnetic shield.	20 mgauss	@ equator
		Motor heat load	< 50 mW	@ 2 K
	Tuner (fast)	Lorentz detuning	< 50 Hz	@ 31.5 MV/m
		Tuning range	1 KHz	
		Magnetic shield.	< 20 mgauss	
		Piezo Heat load	< 50 MW	
	Coupler	Power (operation)	> 400 KW	160 μ s
		Power (process)	> 1,200 (> 400) kW	< 400 (> 400) μ s
		Heat load (2K)	< 0.063 / 0.018 W	Static/dynamic
		Tuning range	1-10 E6	
Cryomodule	Vacuum Vessel	Inner Diameter	946.2 mm	
		Slot Length	12,680 mm	
		Coupler port pitch	1326 mm	
	GHe return Pipe	Diameter	300 mm	
	LHe supply pipe	Diameter	xxx	
	Pre-cooling	Diameter	xxx	

	pipe			
	5 K shield	Yes/no	TBD	Default: yes
	Support			
	Cryogenic prop.	Heat Load	To be filled	

Open columns in the table are 'TBD'.
(can not be decided, now)

Any further comments on this table?

At ALCPG09 (Albuquerque Oct. 2009)

(1) Specifications table for plug-compatibility

(2) Definitions of boundary

(1) Specification Profile Tables

The purpose of table:

- to understand specification of function, specification of physical dimensions.
- to understand what is fixed, what is not fixed, for item by item.
- to facilitate 'Plug compatibility' concept.

Tables visualize the specifications for;
Cavity
Tuner
Coupler

We had the discussion

- at Cavity Kick-off meeting in DESY (Sep. 2007),
- at ML-SCRF meeting in DESY (Jan. 2008),
- at GDE meeting in Sendai (Mar. 2008),
- at ML-SCRF meeting in FNAL (Apr. 2008)
- at GDE meeting in Chicago (Nov.2008)
- at TILC09 GDE meeting in Tsukuba (Apr. 2009)

No progress afterward -> go to next step

PM already developed "plug-compatibility memo" last year. ->need to complete.

Current tables are followings;

cavity	specification item	specification	unit and comments	further comments
RF properties	Frequency	1.30	GHz	
	Number of cells	9.00	cells	
	Gradient	31.50	MV/m	operational
		35.00	MV/m	Vertical test
	Q0	0.80	10¹⁰	at 35
		1.00	10¹⁰	at 31.5
	HOM damping		Q	decide later
			R/Q	decide later
Short range wake			decide later	
Operating temperature	2.00	K		
Physical properties	Length	1247	mm	TESLA-short length
	Aperture		mm	must be compatible with beam dynamics
	Alignment accuray	300.00	um	rms
	Material	Niobium		
	Wall thickness	2.80	mm	
	Stiffness			decide later
	Flange/Seal system		Material	decide later
	Maximum overpressure allowed		2bar	
	Lorentz force detuning over Flat-top at 35 MV/m		1.00kHz	maximum
	Outer diameter He vessel	230.00	mm(inner diameter)	Mag shield outside, decide later for precise number
		230.00	mm(inner diameter)	KEK Mag shield inside, decide later for precise number
	Magnetic shielding		inside/outside	decide later

* yellow boxes indicate 'not fixed'

tuner	specification item	specification	unit and comments	further comments
Slow tuner	Tuning range	>600	kHz	
	Hysteresis in Slow tuning	<10	µm	
	Motor requirement	step-motor use, Power-off Holding, magnetic shielding		
	Motor specification	ex) 5 phase, xxA/phase, ...	match to driver unit, match to connector pin assignment,...	decide later
	Motor location	inside 4K? / outside 300K? / inside 300K accessible from outside?	need availability discussion, MTBF	decide later
	Magnetic shielding	<20	mG at Cavity surface, average on equator	
	Heat Load by motor	<50	mW at 2K	
	Physical envelope	do not conflict with GRP, 2-phase line, vessel support, alignment references, Invar rod, flange connection,...		cable connection, Mag shield
	Survive Frequency Change in Lifetime of machine	~20 Mio. steps	could be total number of steps in 20 years,	

* yellow boxes indicate 'not fixed'

Fast tuner	Tuning range	>1	kHz over flat-top at 2K	
	Lorentz detuning residuals	<50	Hz at 31.5MV/m flat-top	(LD and microphynics? or LD only?) :decide later
	Actuator specification	ex) low voltage piezo 0-1000V, ...	match to driver unit, match to connector pin asignment, ...	decide later
	Actuator location	insdie 4K?/inside 4K accessible/inside 100K? accesible / inside 300K accessible from outside?		decide later
	Magnetic shielding	<20	mG at Cavity surface average	
	Heat Load in operation	<50	mW	
	Physical envelope	do not conflict with GRP, 2-phase line, vessel support, alignment references, Invar rod, flange connection,...		
	Survive Frequency Change in Lifetime of machine	>10 ¹⁰	number of pulses over 20 years, (2x10⁹:operational number)	

* yellow boxes indicate 'not fixed'

Coupler	condition	specification	unit and comments	further comments
Power requirements	Operation	>400	kW for 1600 us	
	Processing	>1200	kW upto 400 us	need after vac break, cool-down
		>600	kW larger than 400 us	need after vac break, cool-down
Processing with reflection mode		>600	kW for 1600us	in Test stand
Processing time	warm		<50 hours	after installation, definition of power/pulse_width target are the same as 'Power Requirement' above.
	cold		<30 hours	after installation, definition of power/pulse_width target are the same as 'Power Requirement' above.
Heat loads /coupler	2K static	< 0.063	W	
	5K static	< 0.171	W	depend on tunability
	40 K static	< 1.79	W	
	2K dynamic	< 0.018	W	
	5K dynamic	< 0.152	W	
	40K dynamic	< 6.93	W	
Cavity vacuum integrity	# of windows	2		
	bias capability	yes		
RF Properties	Qext		tunable	
	Tuning range	1-10	10 ⁶ if tunable	
Physical envelope	Position		compatible to TTF-III	decide later
	Flange		compatible to TTF-III	decide later (to cavity, to cryostat)
	waveguide		compatible to TTF-III	decide later
	support		compatible to TTF-III	decide later
Instrumentation	vacuum level	>= 1		
	spark detection		0 at window	
	electron current detection	>= 1	at coax	
	temperature	>= 1	at window	

* yellow boxes indicate 'not fixed'

Plug compatible conditions at Cavity package (proposal)

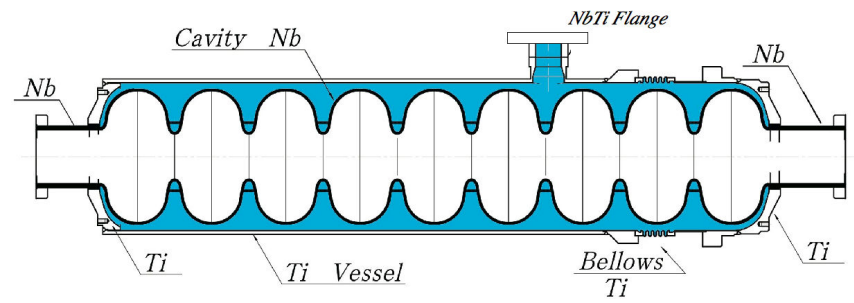
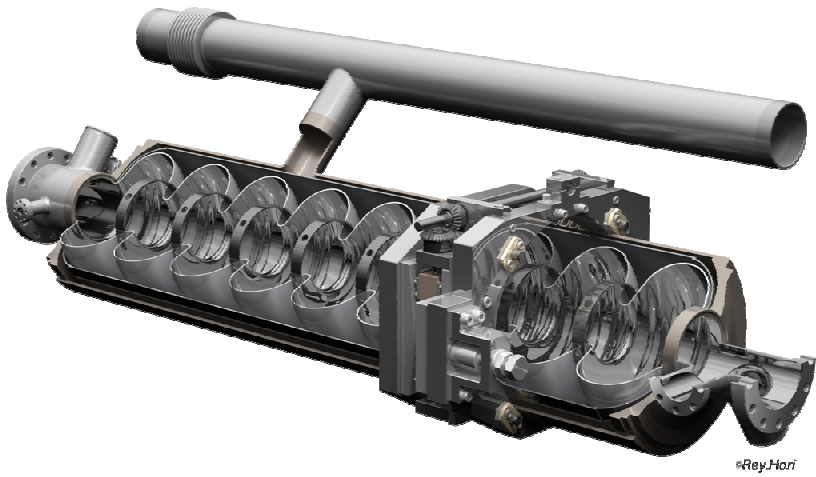

Item	Can be flexible	Plug-compatible
Cavity shape	TESLA /LL /RE	
Length		Required
Beam pipe dia		Required
Flange		Required
Tuner	blade/slide-jack	
Coupler flange		Required
He-in-line joint		Required

Cavity boundary

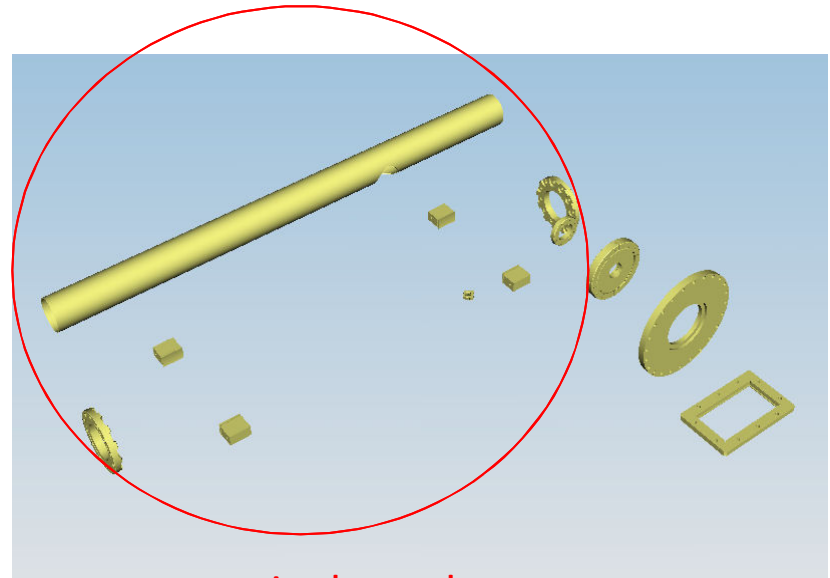
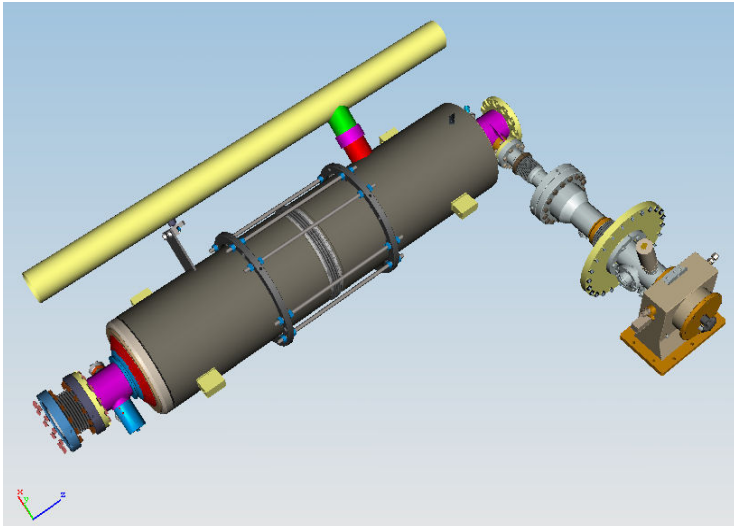

- (1) beam pipe port flange
- (2) coupler port flange
- (3) 4 support tabs
- (4) He pipes

Input coupler boundary

BCD: TTF3 coupler

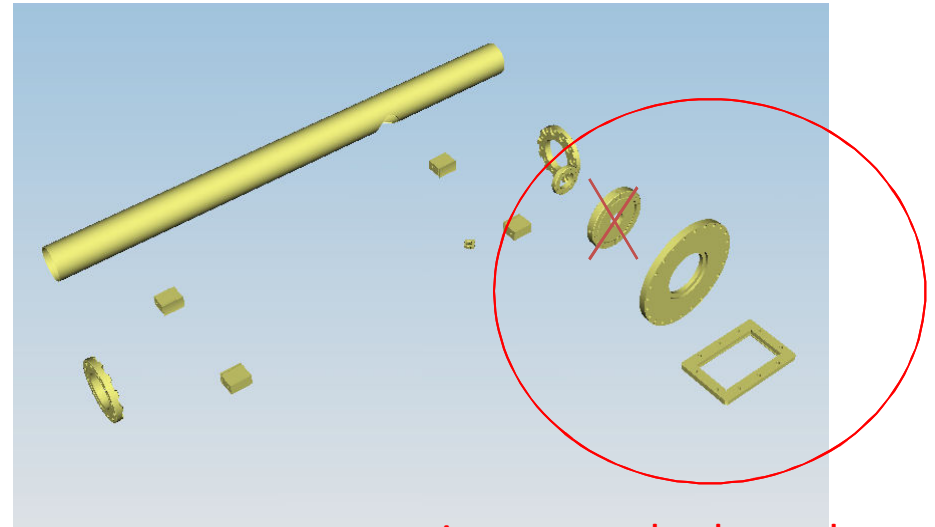
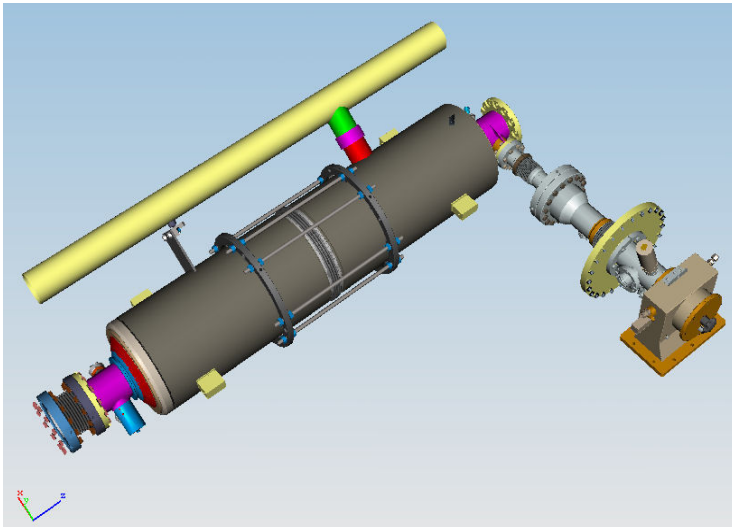

input coupler boundary

- (1) cavity port flange
- (2) cryostat vessel flange
- (3) waveguide flange

Next Plan for plug-compatibility

- **Complete document anyway**
plug-compatibility level,
component specification,
boundary definition,
guide-line
drawings, etc.
- **circulate document**