

Status of the optical cavity R&D at ATF

T.Takahashi
Hiroshima University
for collaborators

LCWS10
27-March-2010

Proposed telescopic, passive, resonant external cavity

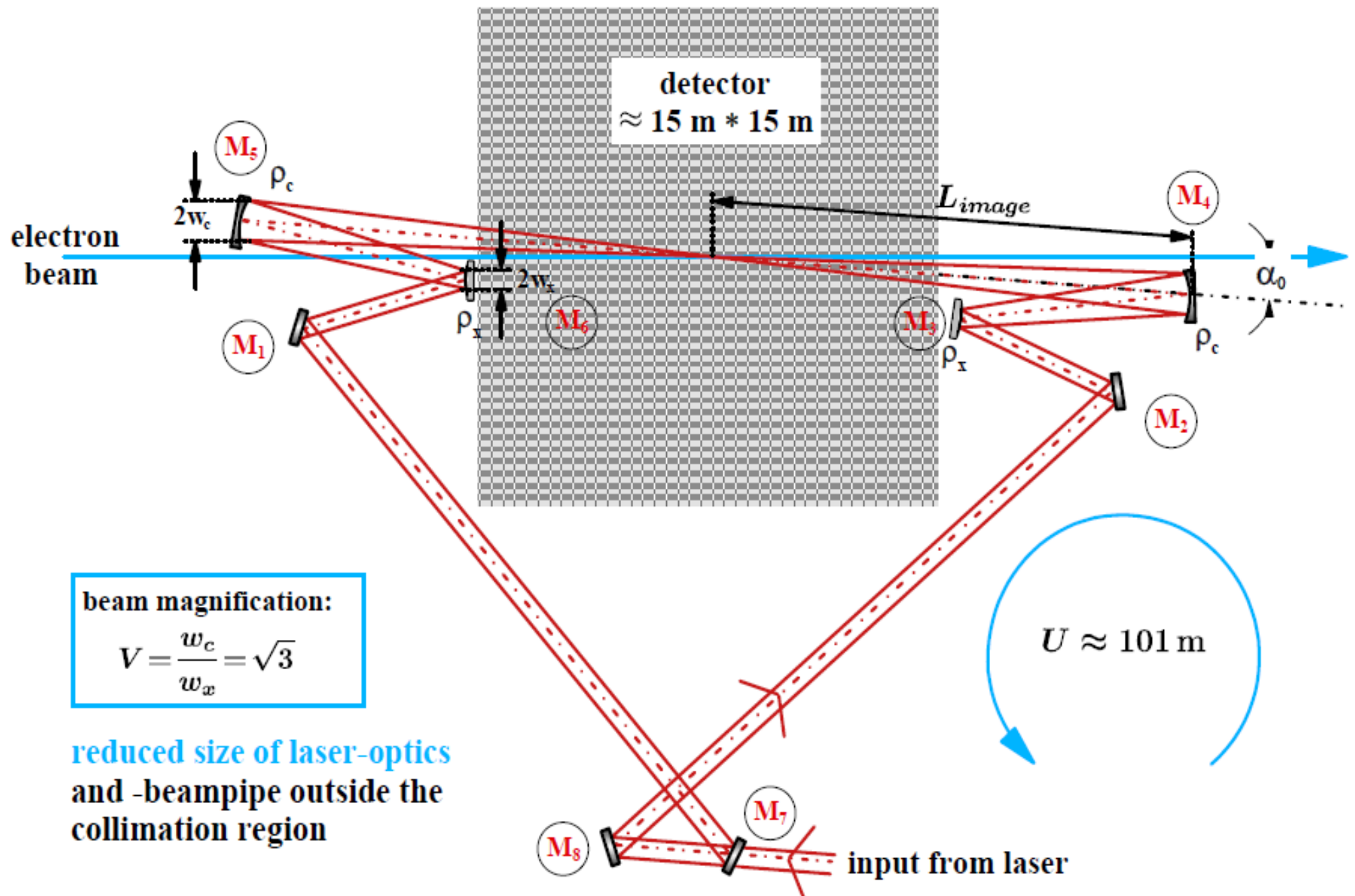

Proposed telescopic, passive, resonant external cavity

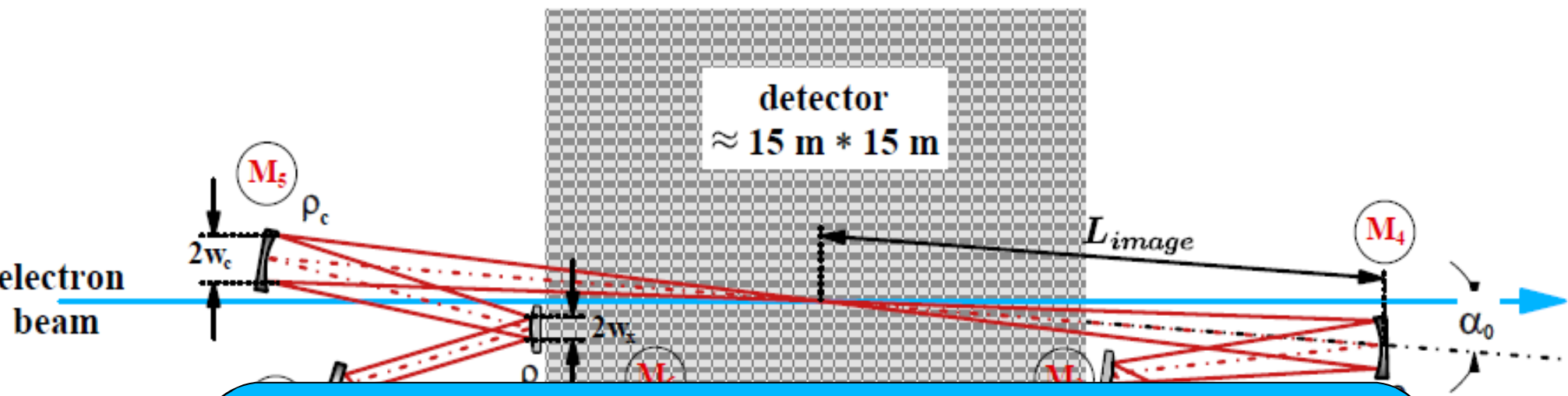

no dedicated R&D program for photon colliders
 but projects for laser-Compton scattering with
 optical cavity
 Polarized positron sources
 x-ray sources

beam m

$$V = \frac{w_c}{w_x} = \sqrt{3}$$

reduced size of laser-optics
and -beampipe outside the
collimation region

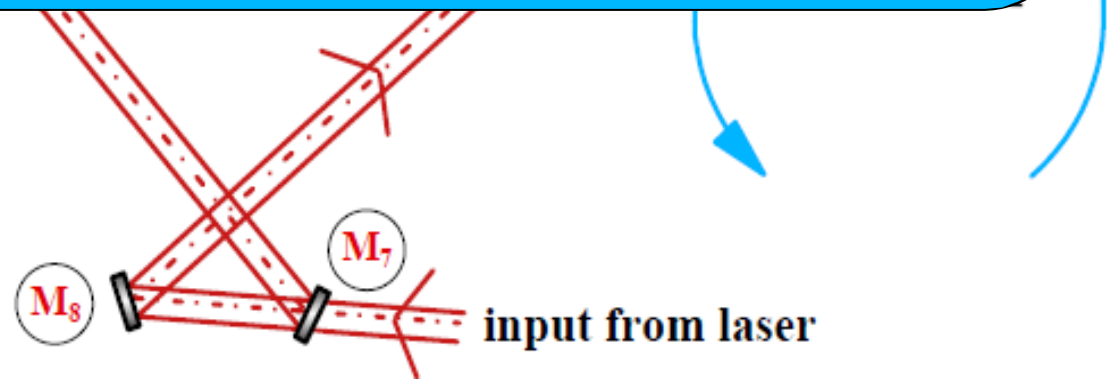

Two Prototype Cavities

2-mirror cavity (Hiroshima / Weseda /
Kyoto / IHEP / KEK)



moderate enhancement
moderate spot size
simple control

demonstration of γ ray gen.
accum. exp. w/ cavity and acc.

4-mirror cavity

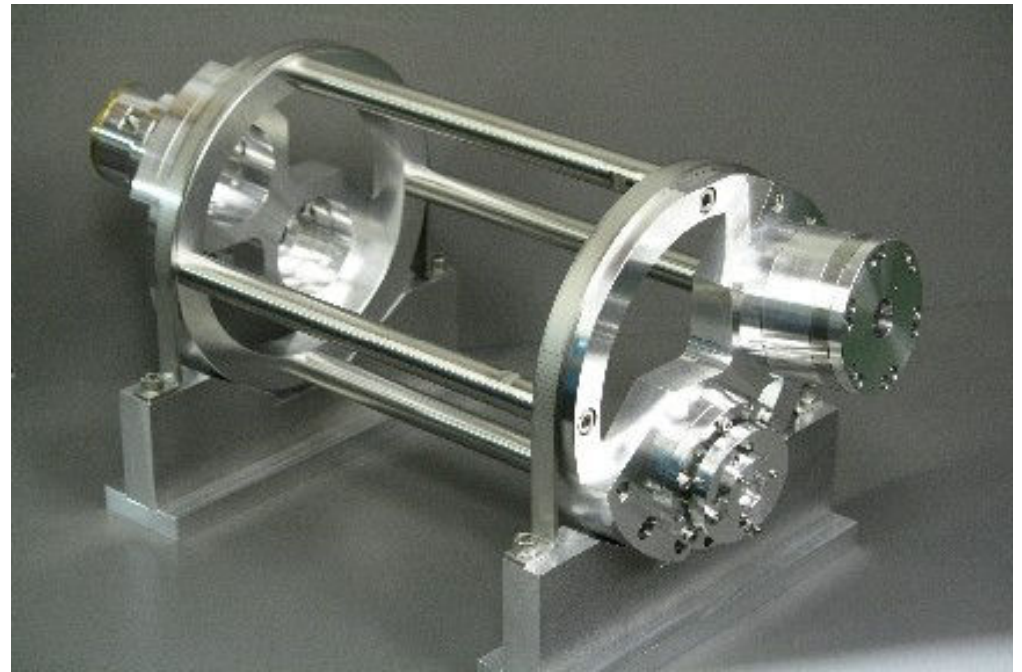

high enhancement
small spot size
complicated control

intense γ ray generation

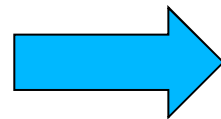

STATUS OF THE 2 MIRROR CAVITY

Experimental R/D in ATF

Hiroshima-Waseda-Kyoto-IHEP-KEK

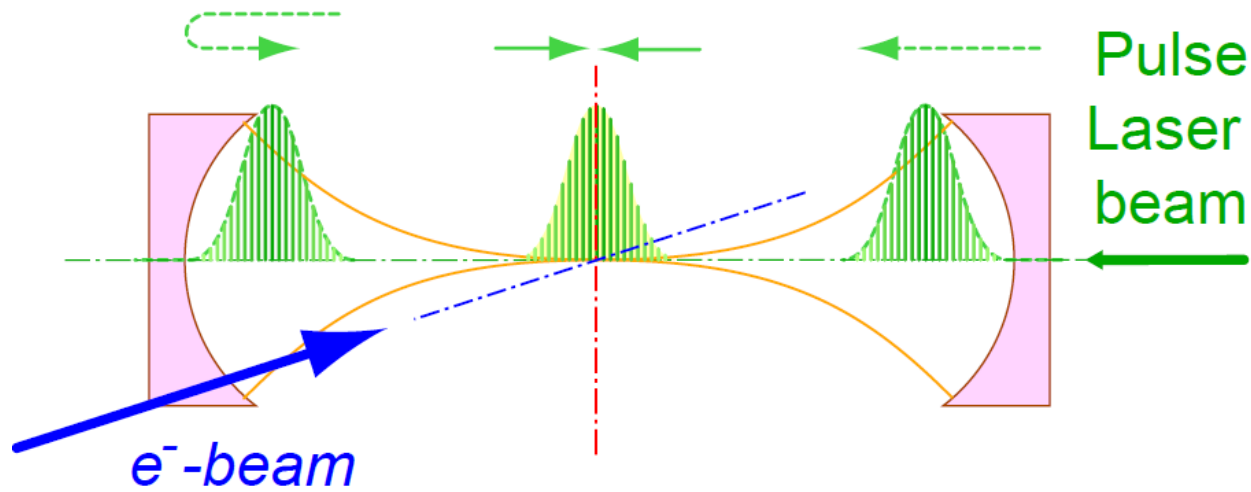

prototype
2-mirror cavity

$L_{cav} = 420 \text{ mm}$

Put it in
ATF ring

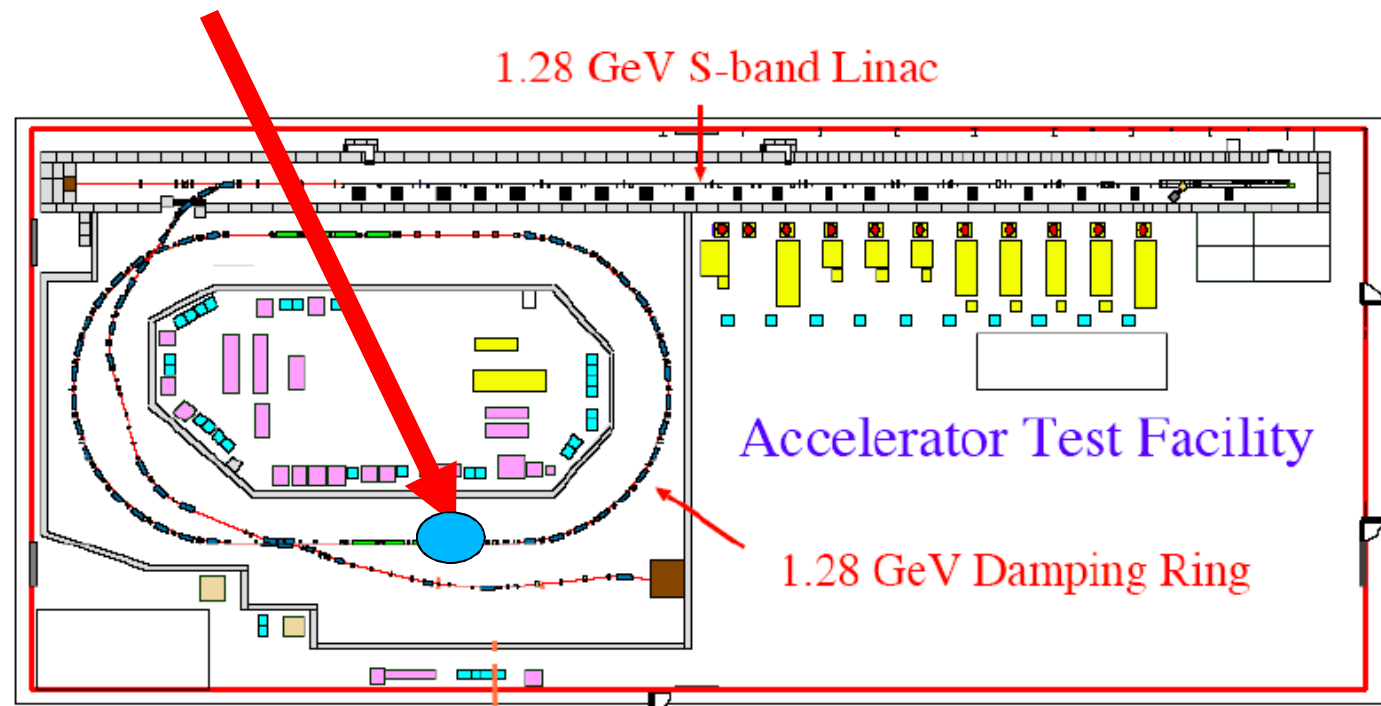

Result as of 2008 (Reported TILC09)

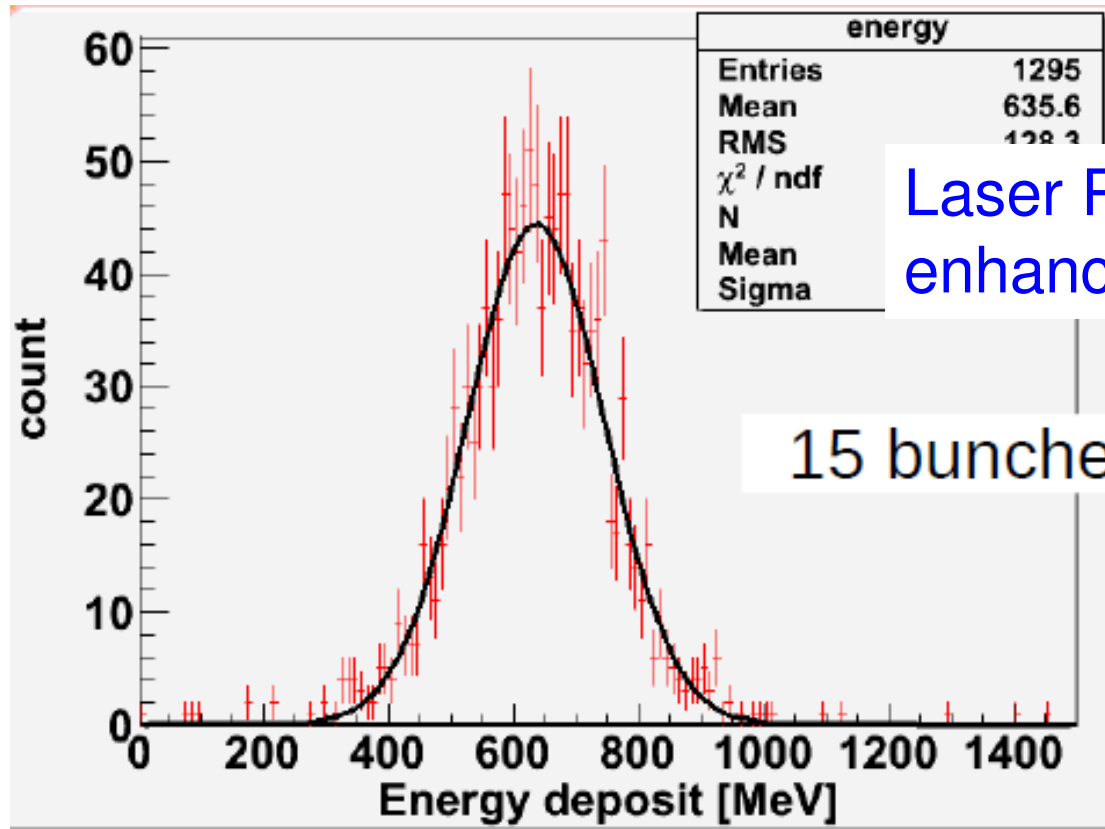

Laser Power ~500W
enhancement 250

15 bunches / train

27 gamma ray / crossing

Next step

more power enhancement

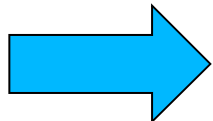

bunch by bunch observation

AFTER TILC09

slide at ALCPG09

- ▶ One of the Mirror was replaced with the higher reflectivity one

- 99.6% -> 99.9%

- power enhancement

- 250 -> ~750

(
99.6% 99.9%

- more precise controll required (~0.1nm)

- ▶ Status of the cavity w/ new mirror

- Finess ~2000 with feedback on before vacuum on

- now in preparation for beam

- hope to get 3 times more photons by the end of the year

W/ Larger enhancement cavity in 2009

After, extensive studies;

Power enhancement of the cavity \sim factor 3

Laser power 500W to 1.48kW

- ▶ 10.8γ /train at 1 bunch (2.2mA)
- ▶ 26.8γ /train 10 bunches (6.7mA)

The electron beam was not tuned enough in 2009

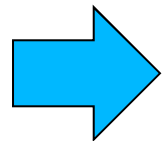
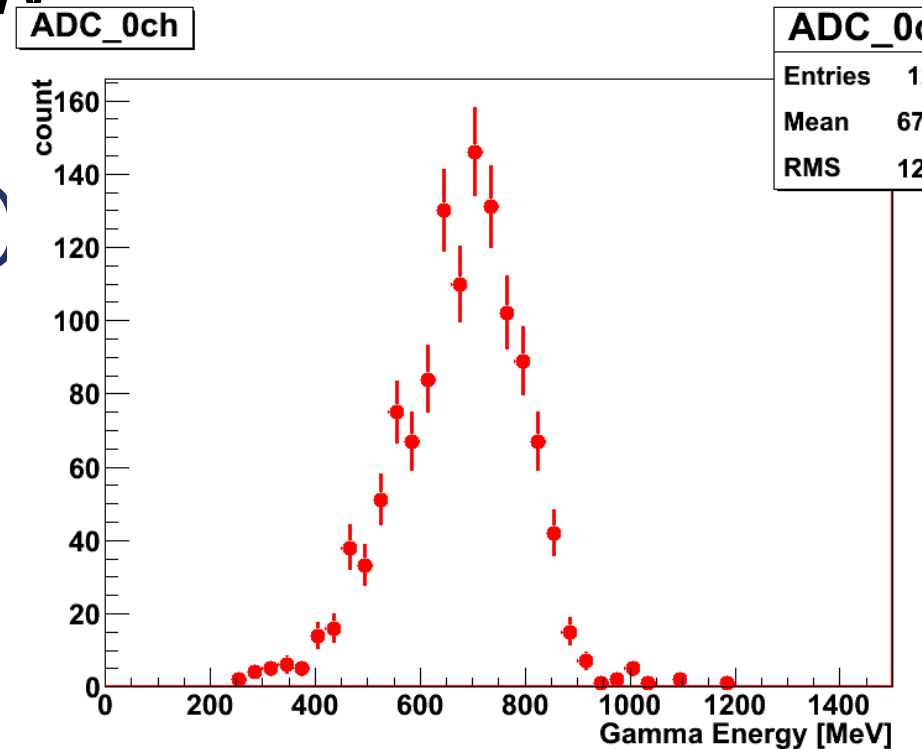

demonstration of 3 times more γ by beam tuning bunch by bunch observation soon

4 MIRROR CAVITY

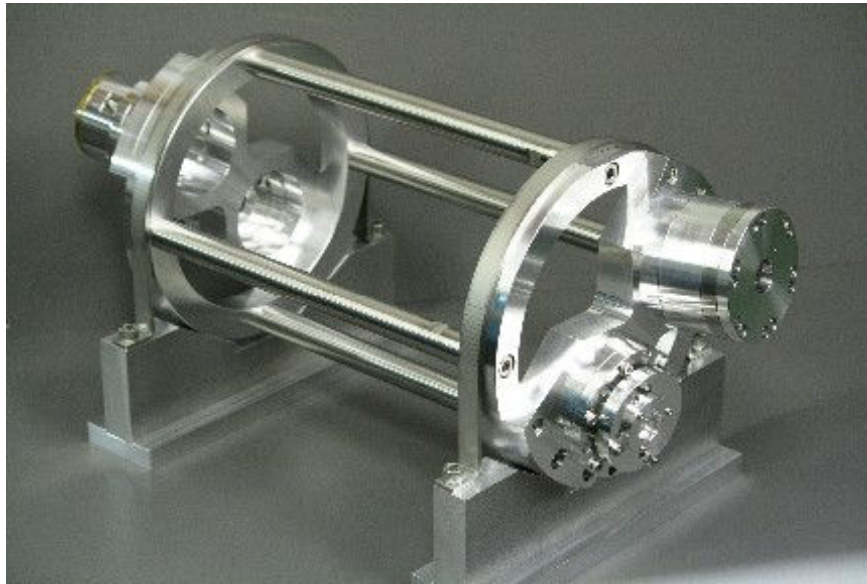

to get higher enhancement and smaller beam waist

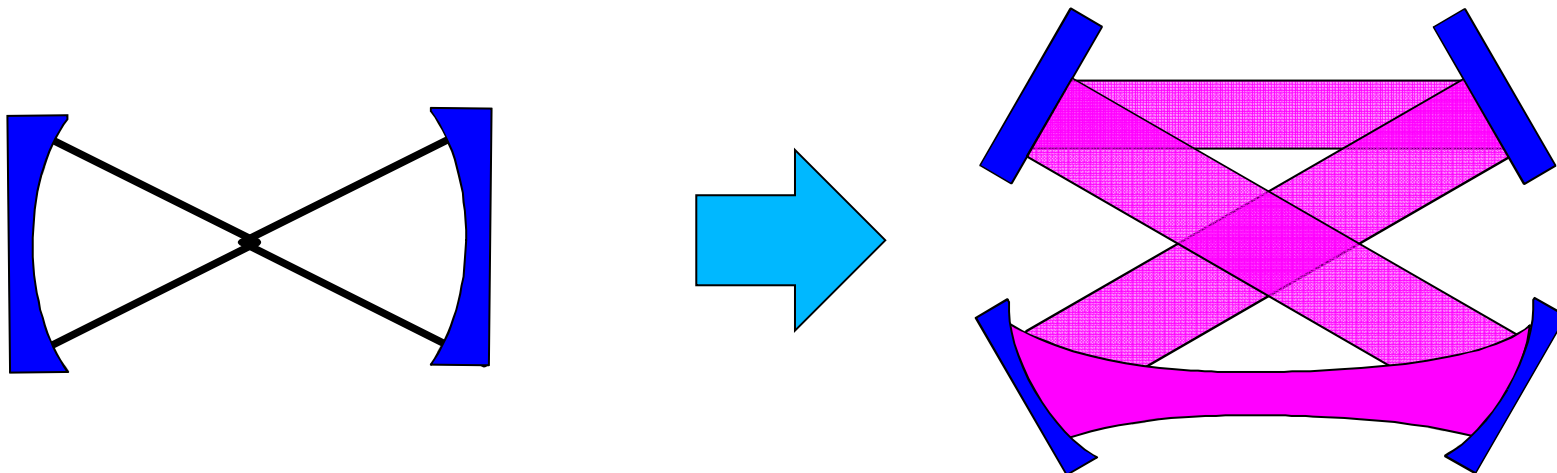

2D configuration

2D 4mirror cavity has astigmatism.

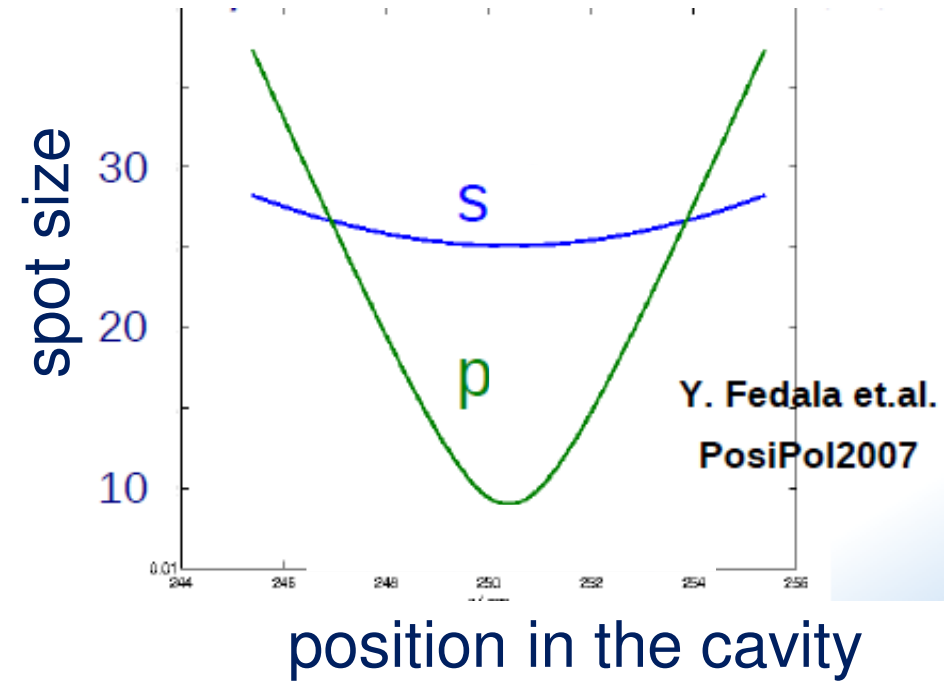

3D configuration

go to 3D config. to avoid astigmatism

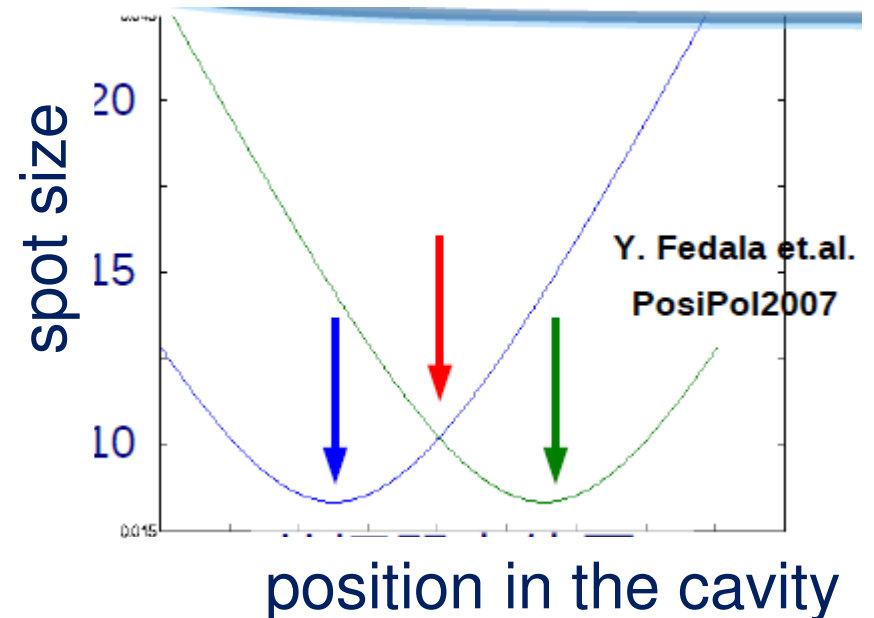
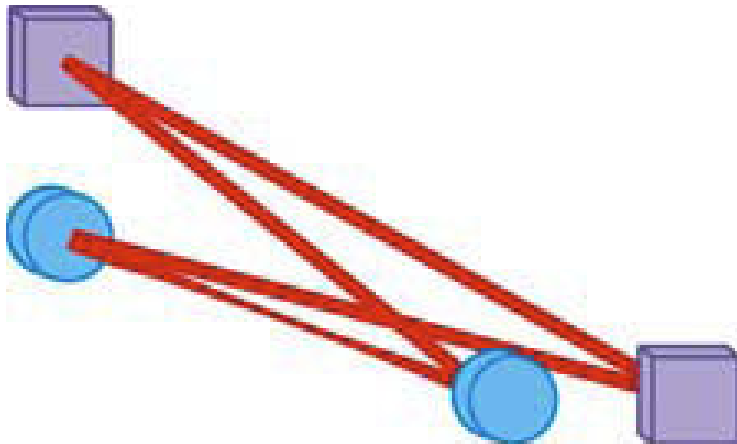

2D configuration

2D 4mirror cavity has astigmatism.

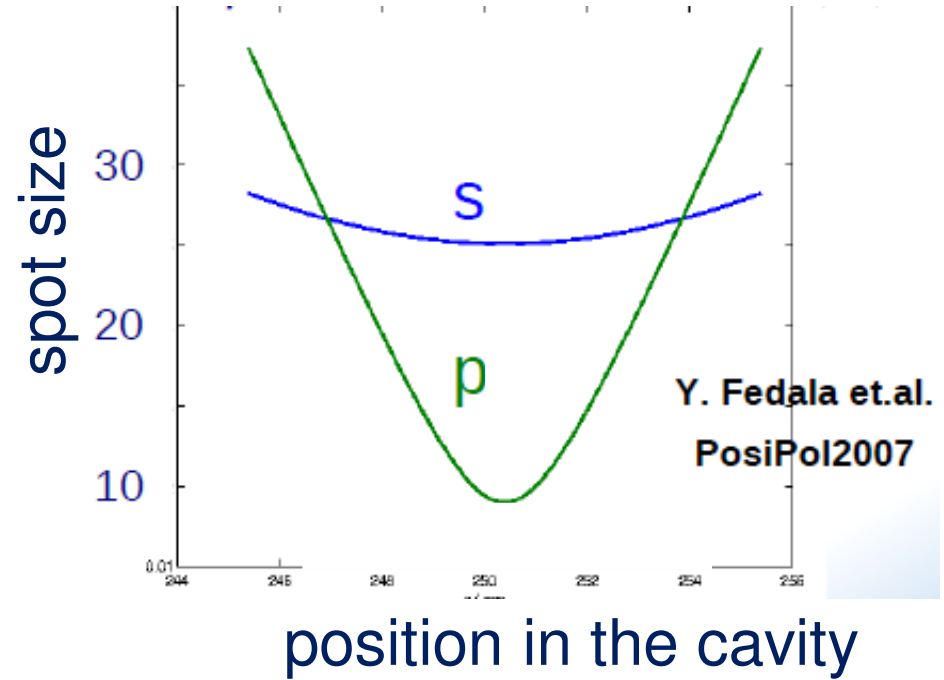

3D configuration

go to 3D config. to avoid astigmatism

However,,,,,
Life was not so simple,,,,,,

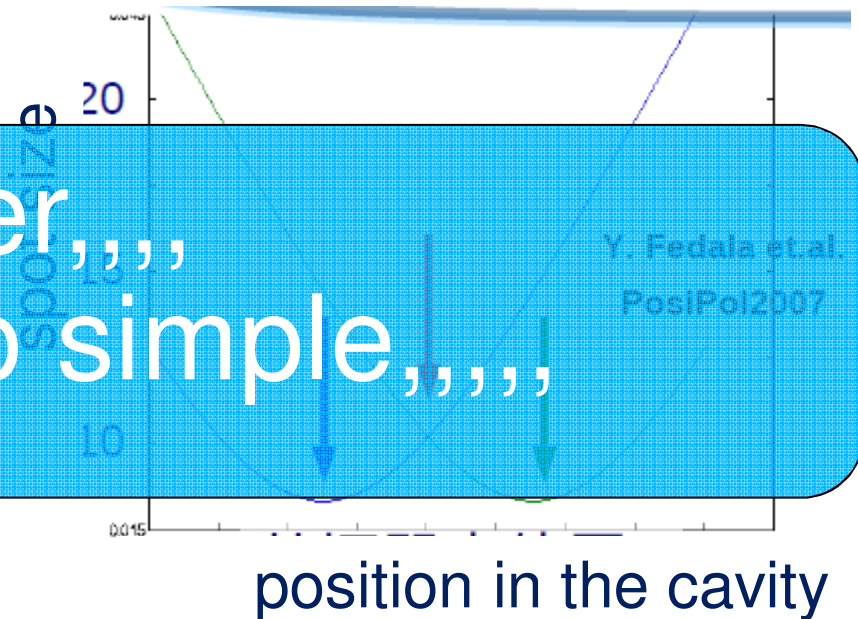

A prototype 3D4M cavity

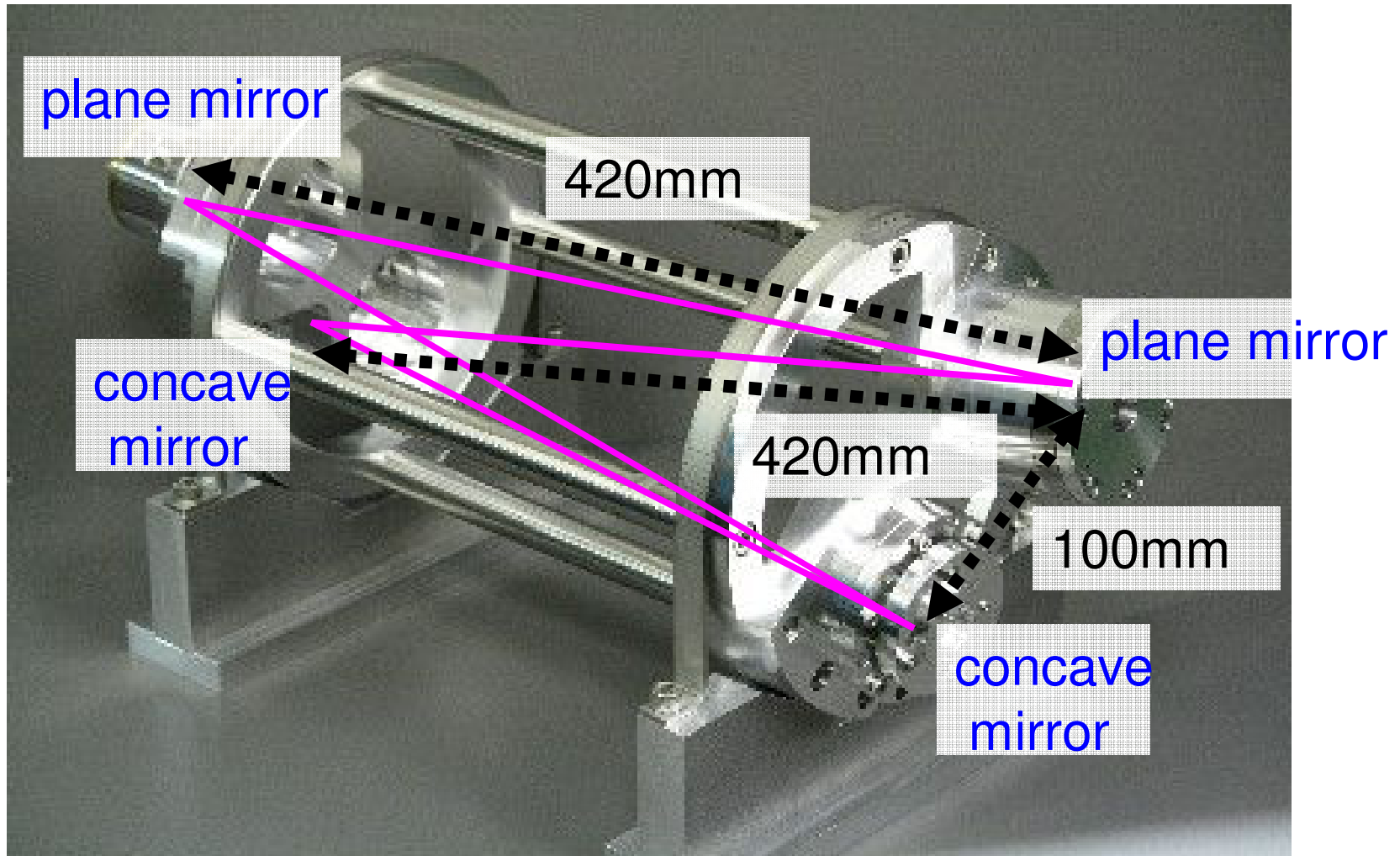

Property of 4M cavity

δ : keeping circumference constant while changing distance between mirrors

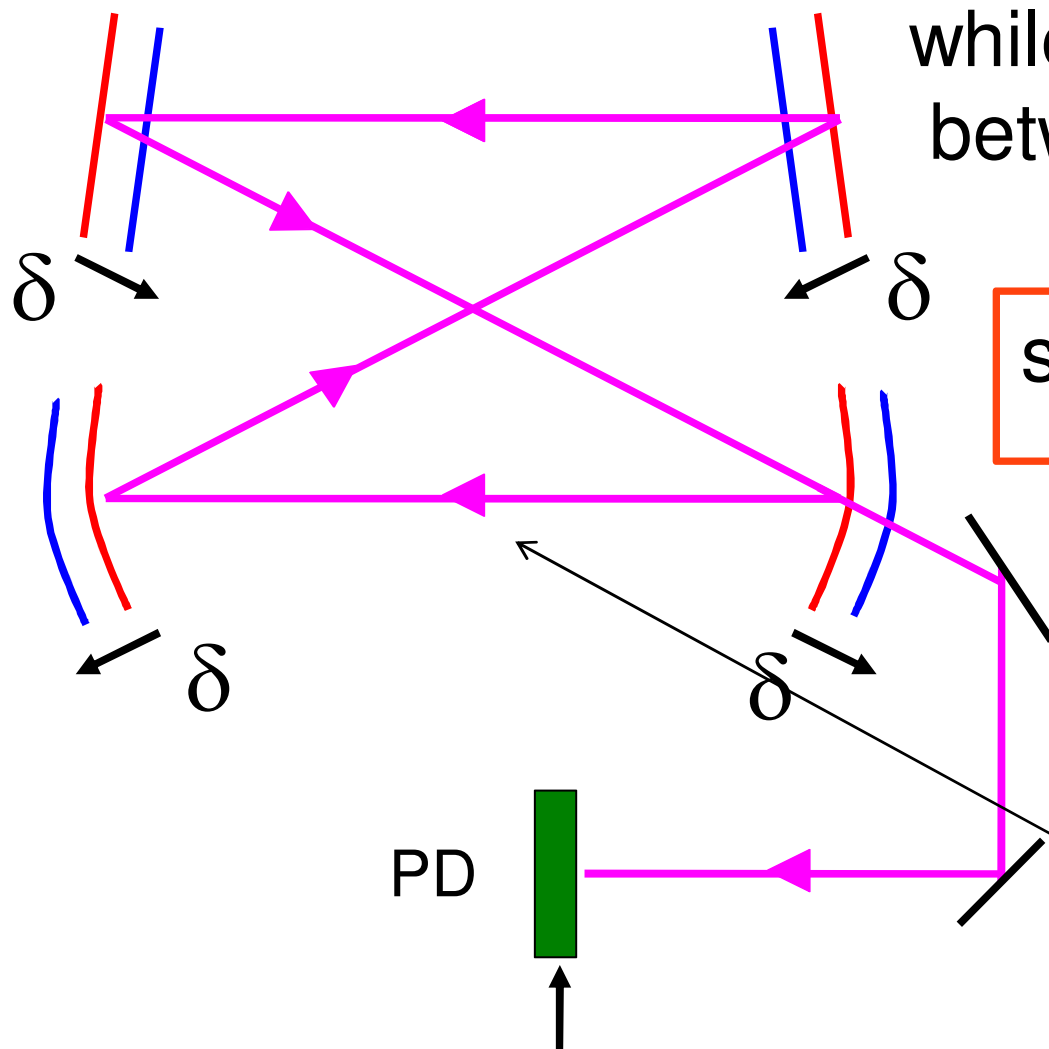

smaller δ : smaller beam waist

measure beam profile here-->estimate beam size in the cavity

Profile of transmitted light

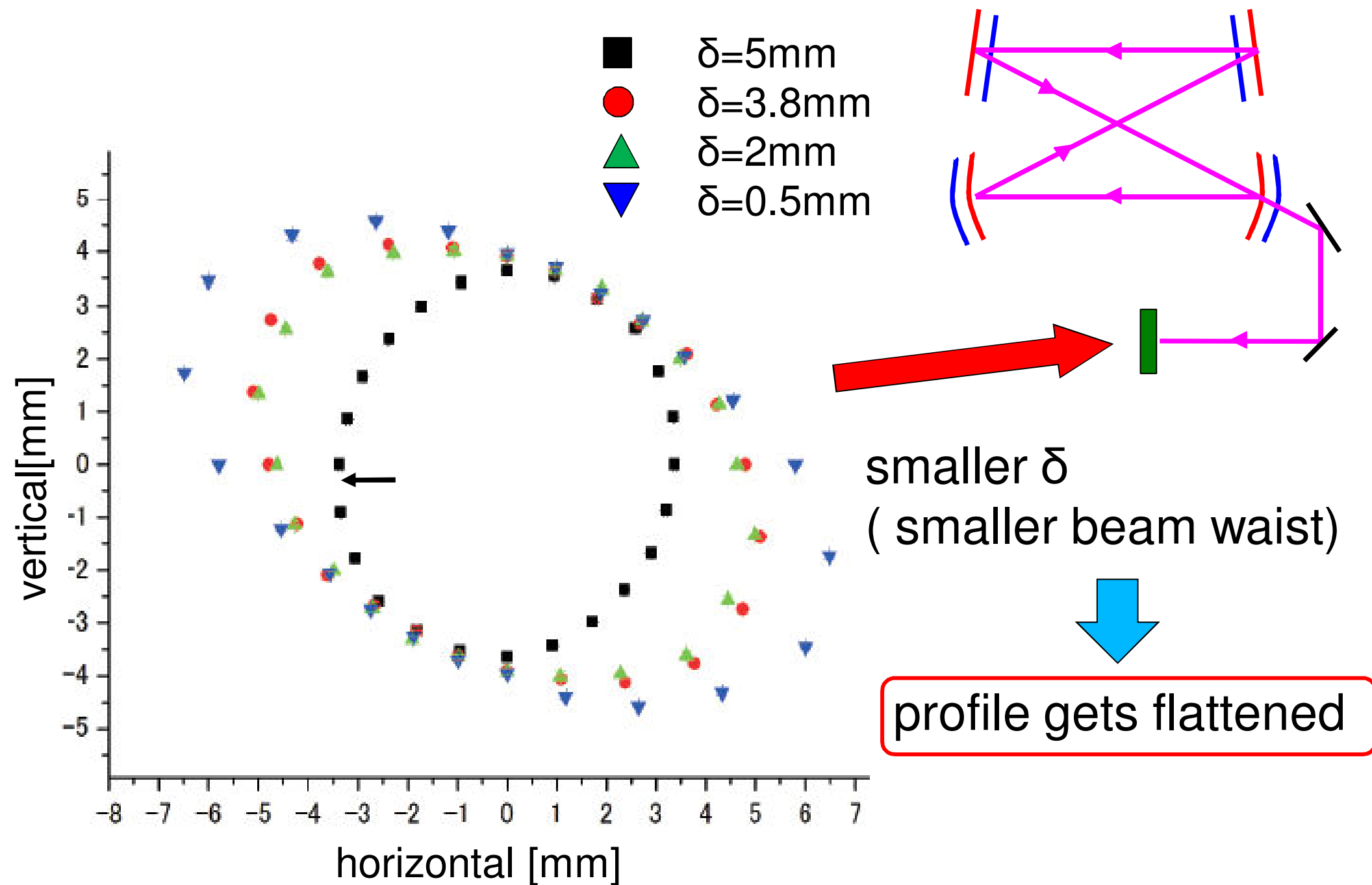
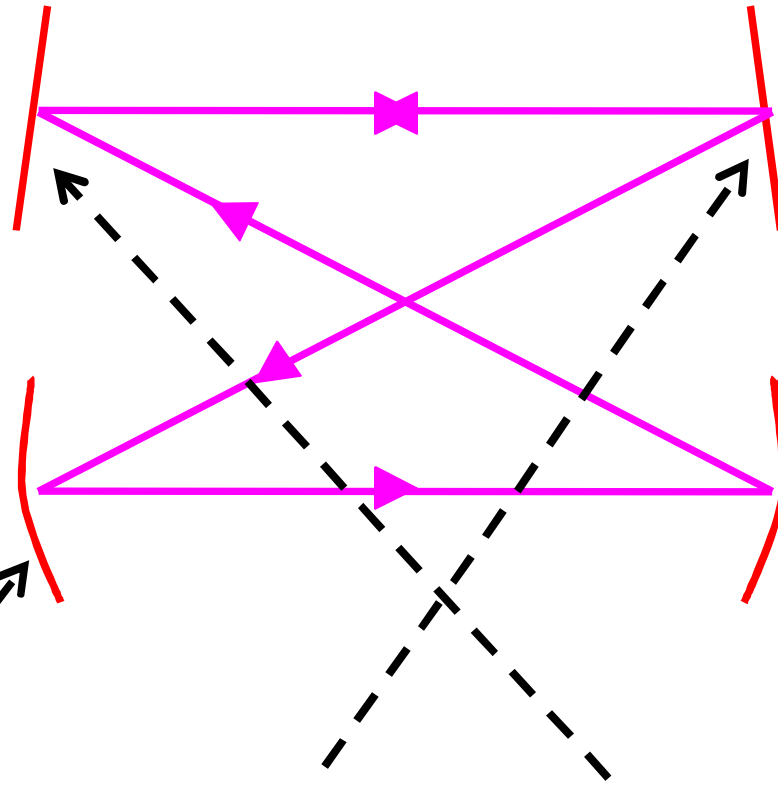

Image rotation during light propagation



$$M(z) = D(L/2) \cdot R(\theta) \cdot F(f_2, f_1) \cdot D(L) \cdot R(\theta) \cdot D(L) \cdot R(\theta) \cdot D(L) \cdot \underline{R(\theta)} \cdot F(f_1, f_2) \cdot D(L/2)$$

$$R[\theta] = \begin{pmatrix} \cos \theta & \sin \theta & 0 & 0 \\ -\sin \theta & \cos \theta & 0 & 0 \\ 0 & 0 & \cos \theta & \sin \theta \\ 0 & 0 & -\sin \theta & \cos \theta \end{pmatrix}$$

calculated profile around focal point

$\delta=0.2\text{mm}$,

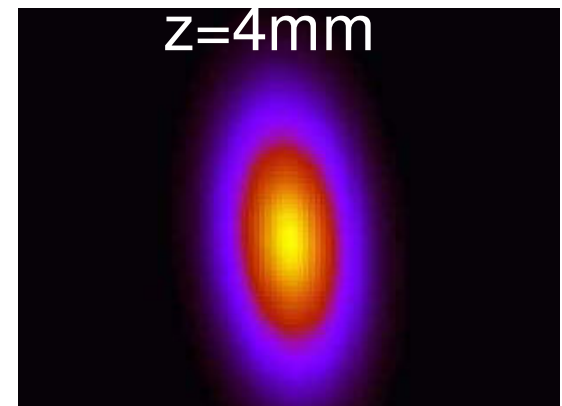
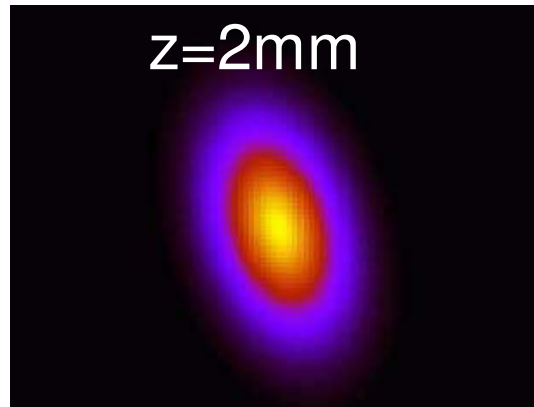
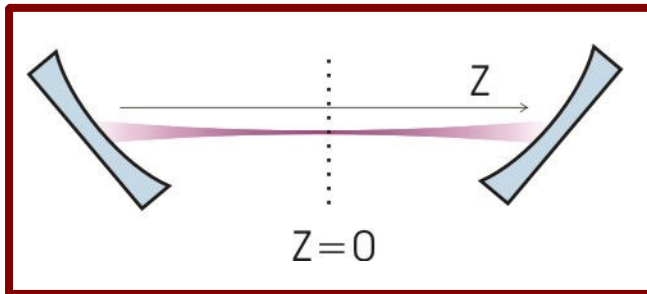
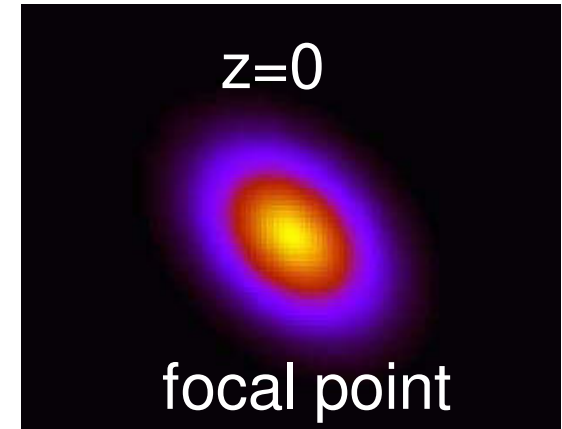
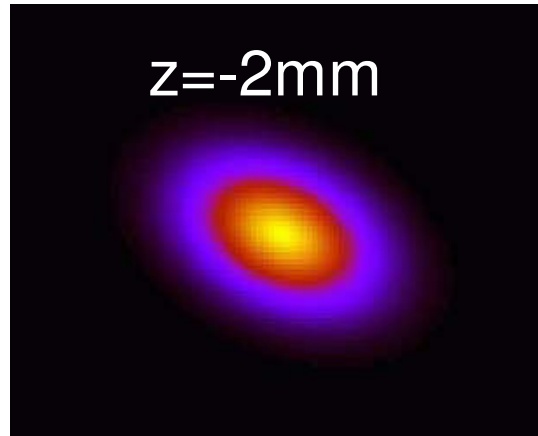
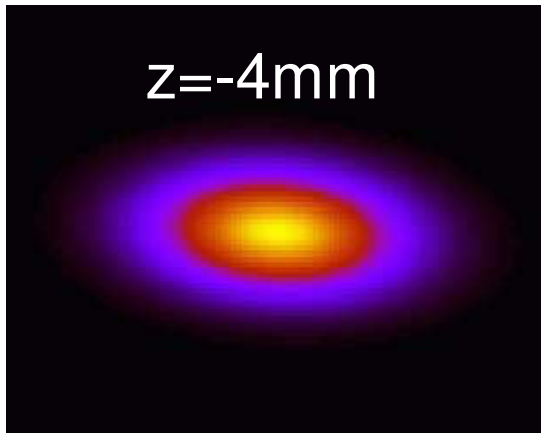

profile is rotating during its propagation!
angular momentum of light

spot size at the center of two focusing mirrors

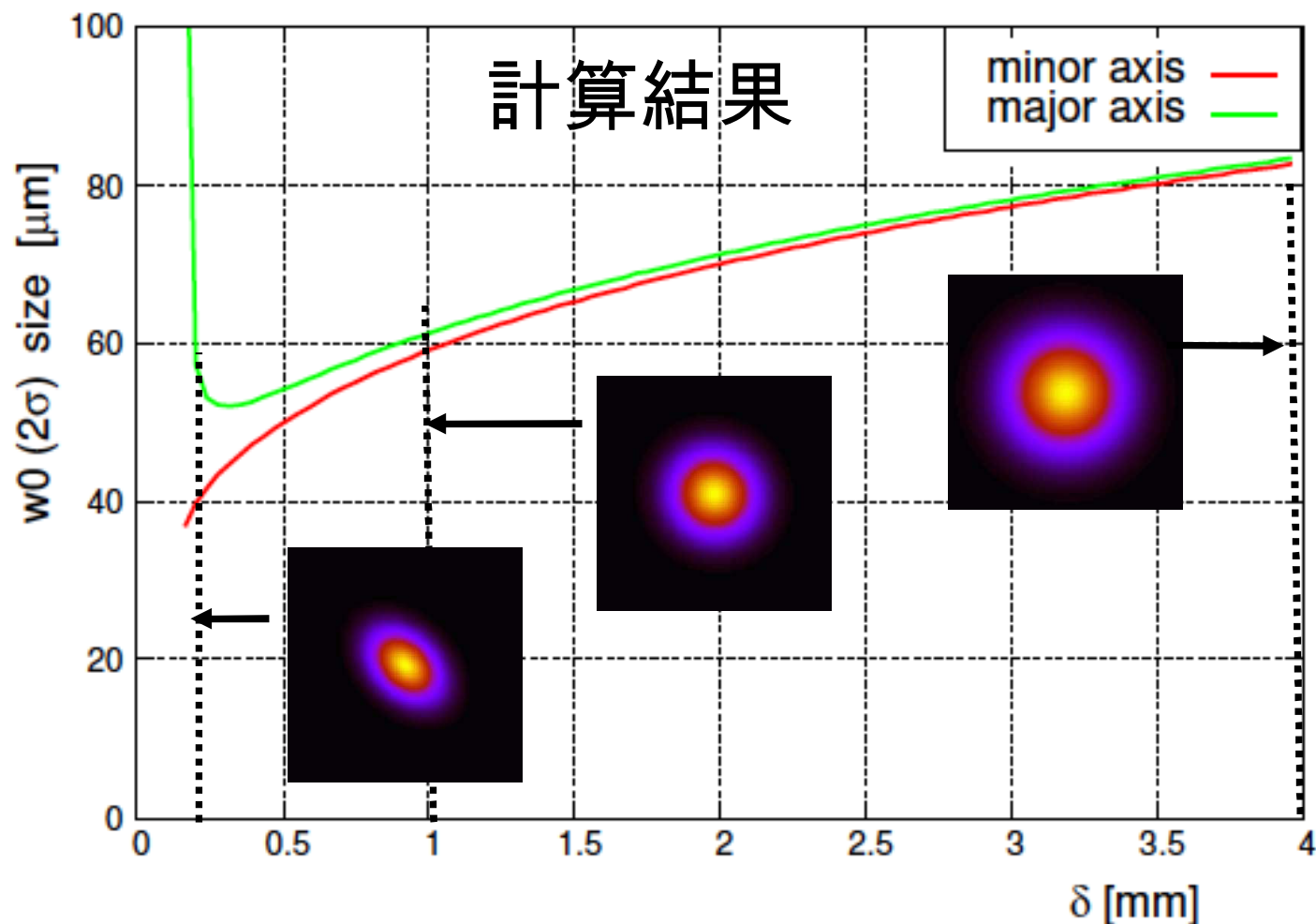

smallest with this prototype
 $2\sigma = (52\ \mu\text{m}, 43\ \mu\text{m})$

need optimization for small waist size

waist size depend L and d

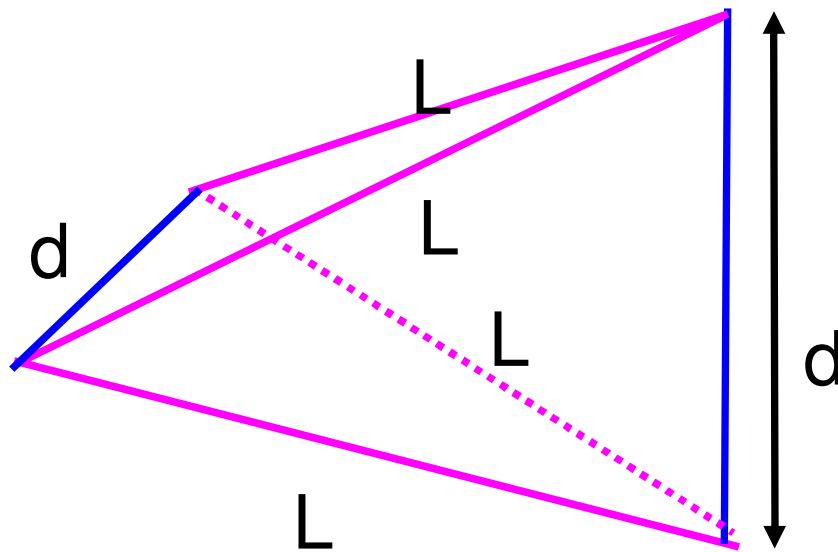

may be:
longer L
smaller d

current prototype
 $L = 420\text{mm}$
 $d = 100\text{mm}$
($52\mu\text{m}, 43\mu\text{m}$)

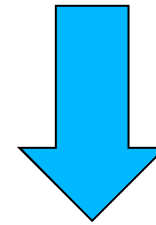

for $L = 420\text{mm}$
 $d = 70\text{mm}$:
($42\mu\text{m}, 39\mu\text{m}$)
 $d = 50\text{mm}$
($40\mu\text{m}, 39\mu\text{m}$)

Summary

- good experience and γ ray demonstration at the ATF with 2 mirror cavity

setp by step and steady improvement

- progress understanding of 4 mirror ring cavity through prototype construction and calculation

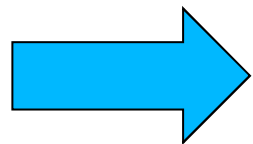

more complicated but interesting feature of 3D cavity

- In near future
 - bunch by bunch information more g ray with 2 M cavity
 - 4M cavity in the ATF ring



Experimental Apparatus

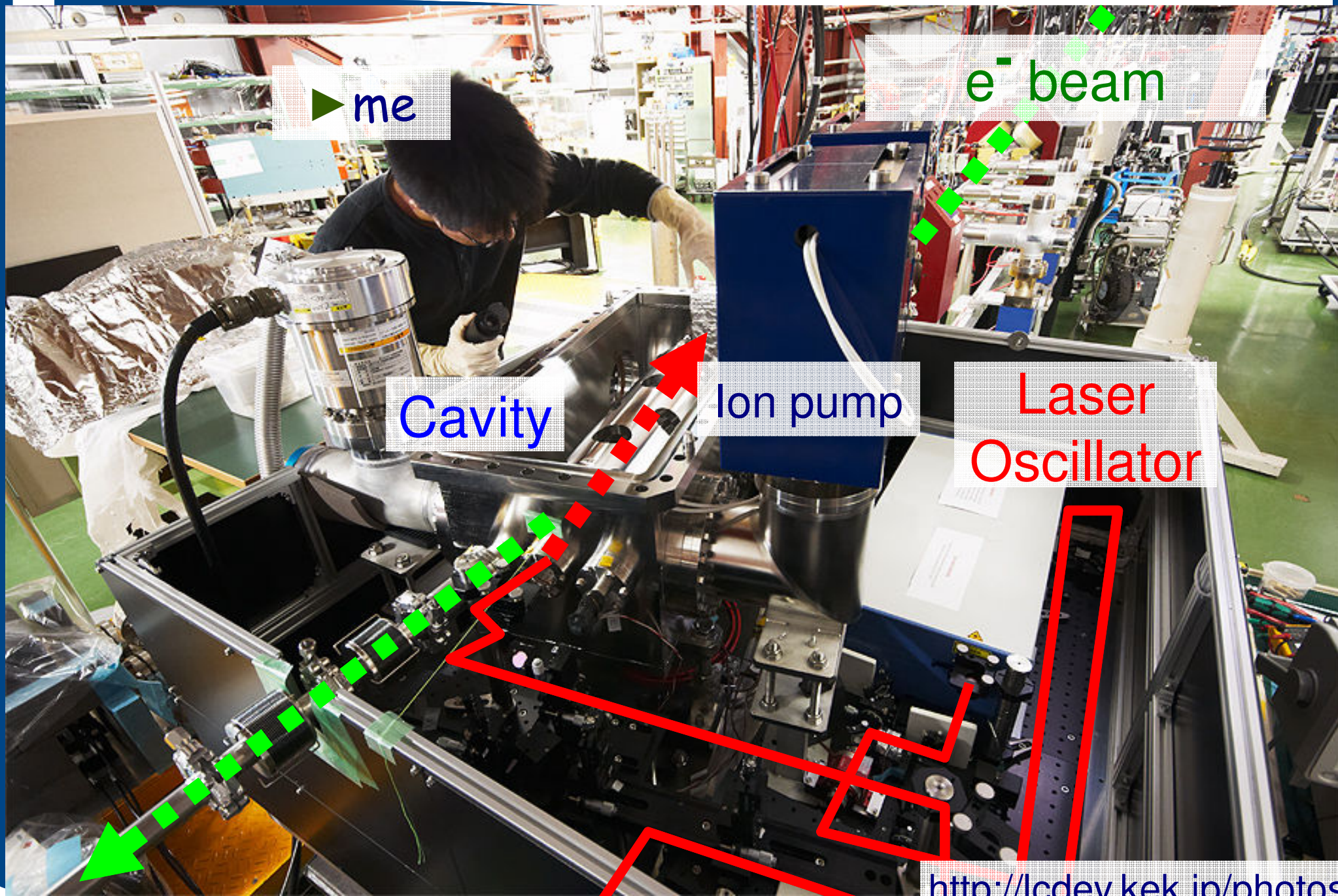

▶ me

e⁻ beam

Cavity

Ion pump

Laser
Oscillator

Optical Cavity for Laser-Compton

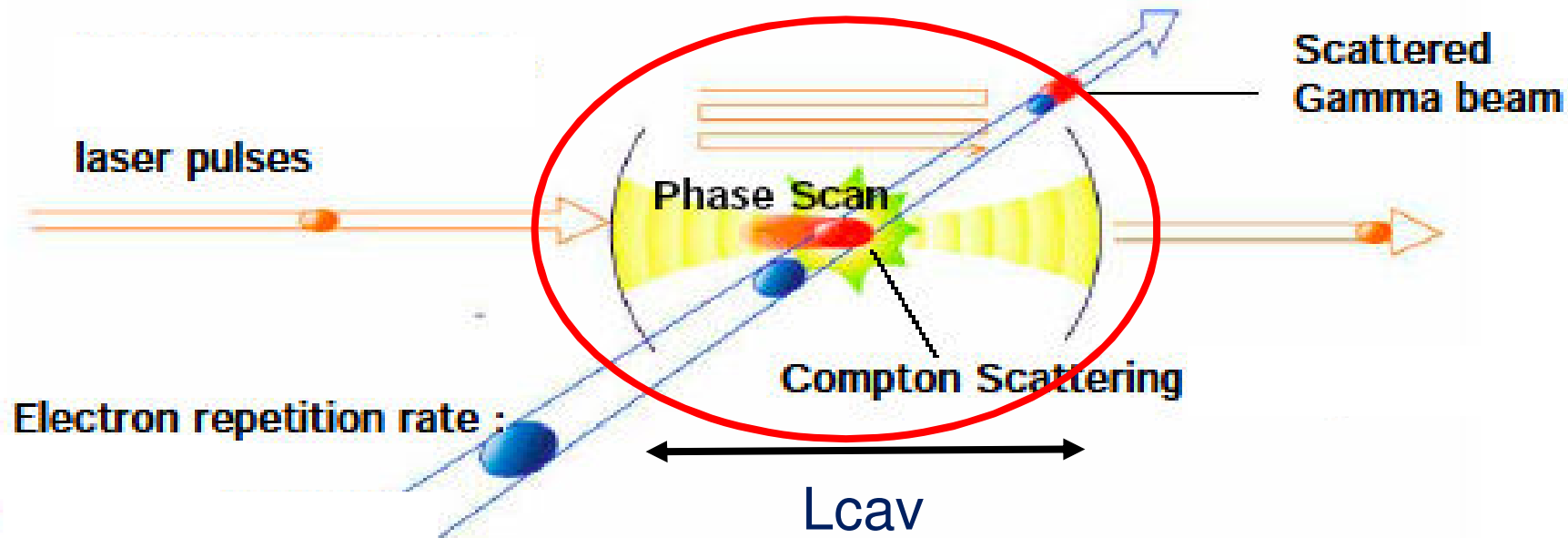

Higher laser power

$L_{cav} = n \lambda/2$, $\Delta L < nm$ laser for pulse stacking

->more enhancement the more precision

$\Delta T < ps$

Laser should be focused for high power density

Accommodate laser cavity in the accelerator

More enhancement More precise control

- ▶ (99.64%, 99.64%) to (99.64%, 99.94%)
- ▶ enhancement: 250 to 760

Width of resonant peak got down to **0.35nm** from 0.60nm

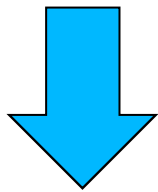

More precise (~faster)
control of cavity

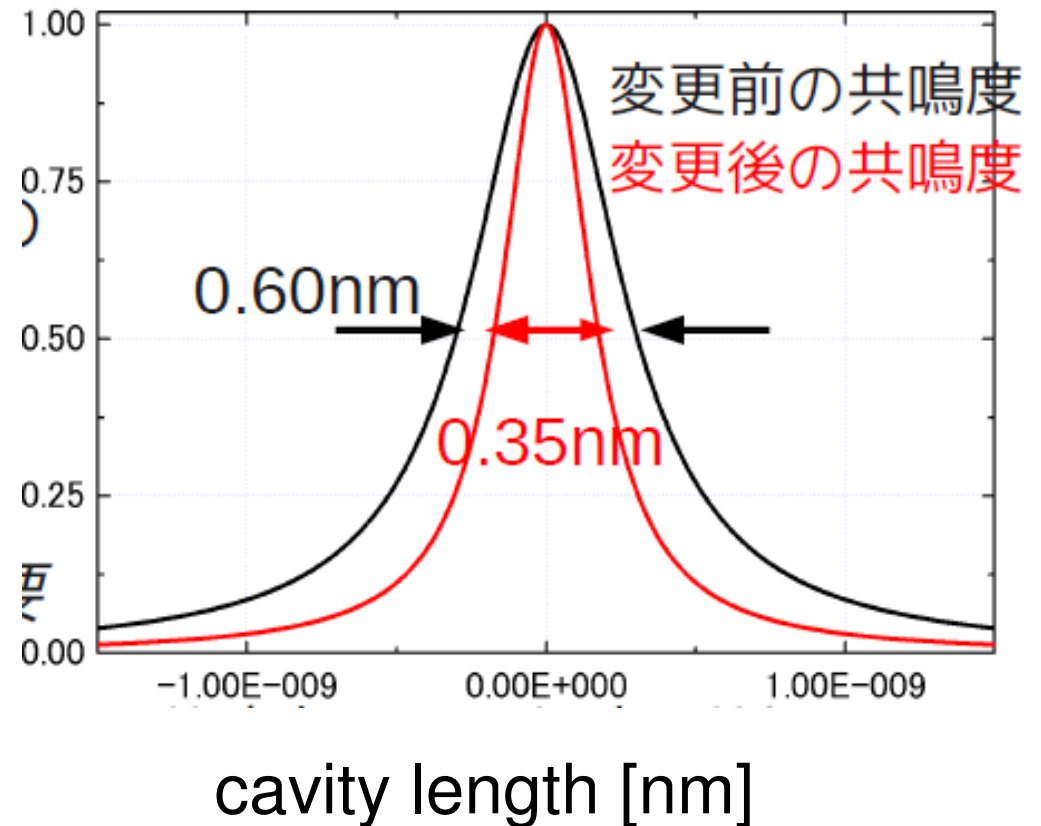

Feed back system in 2008

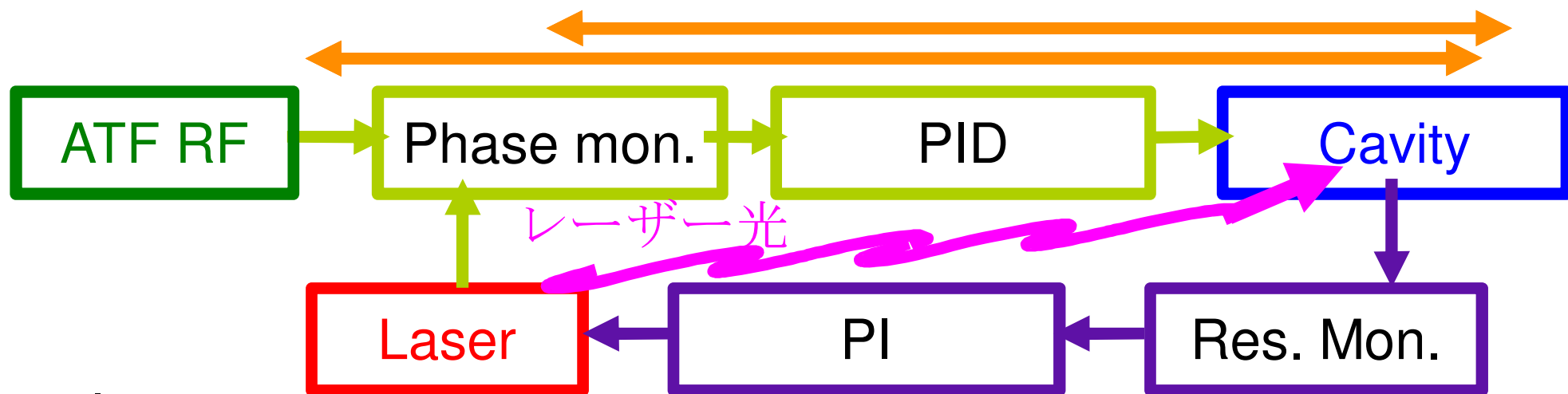

Keeping resonance at 250 enhancement with timing jitter ~ 2 ps

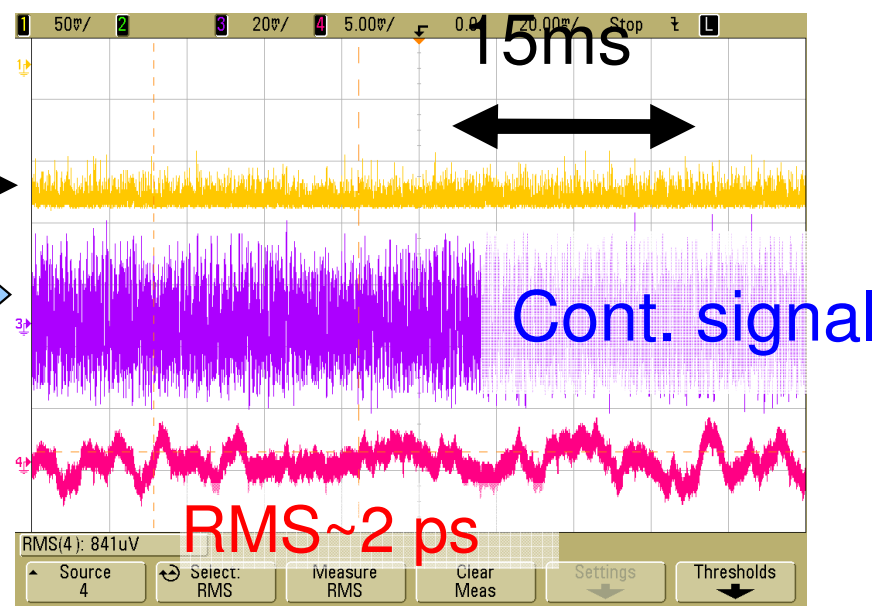
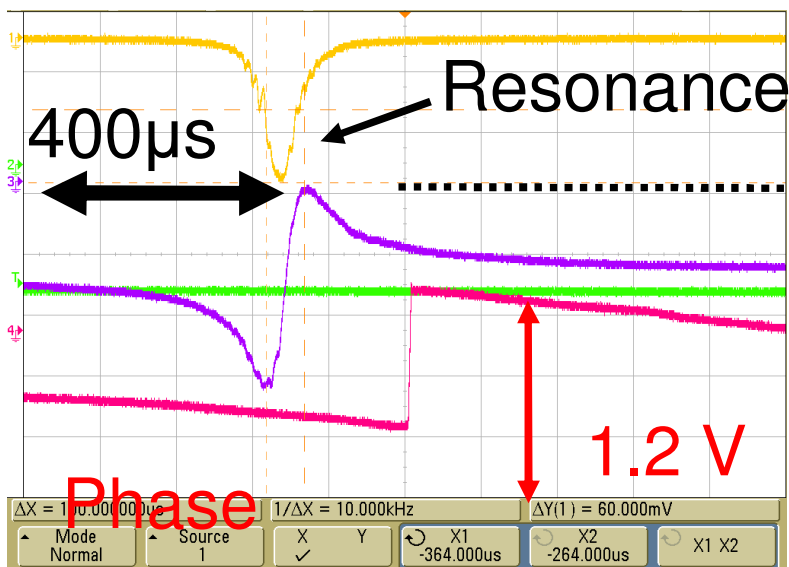

Initial performance with 760 enhancement

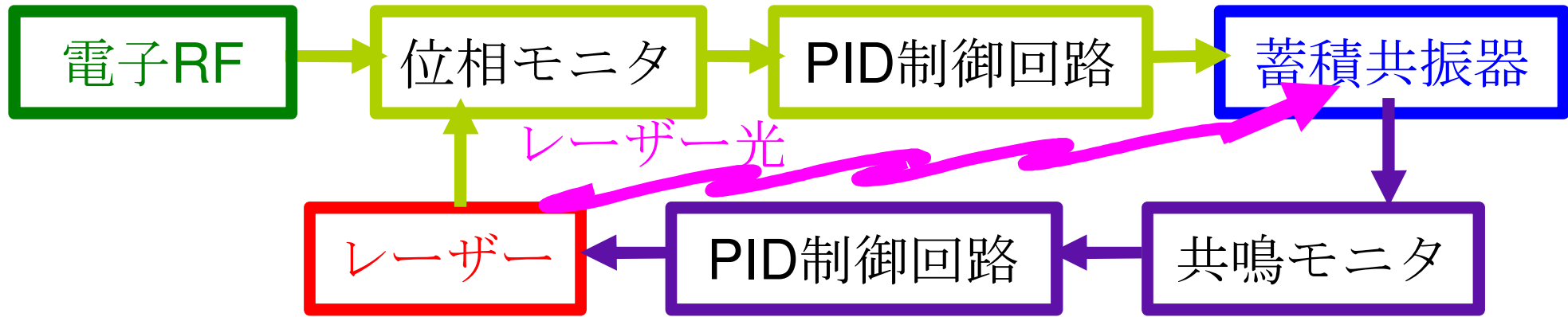

Faster feed back to laser to keep resonance



Larger fluctuation of laser timing



timing control could not follow

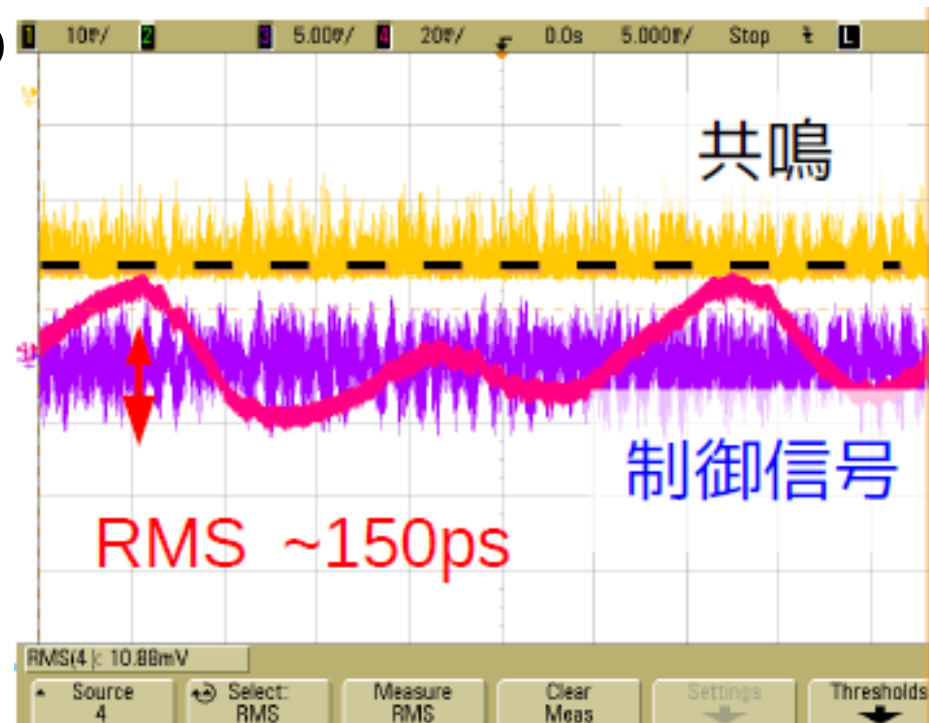

New feedback system

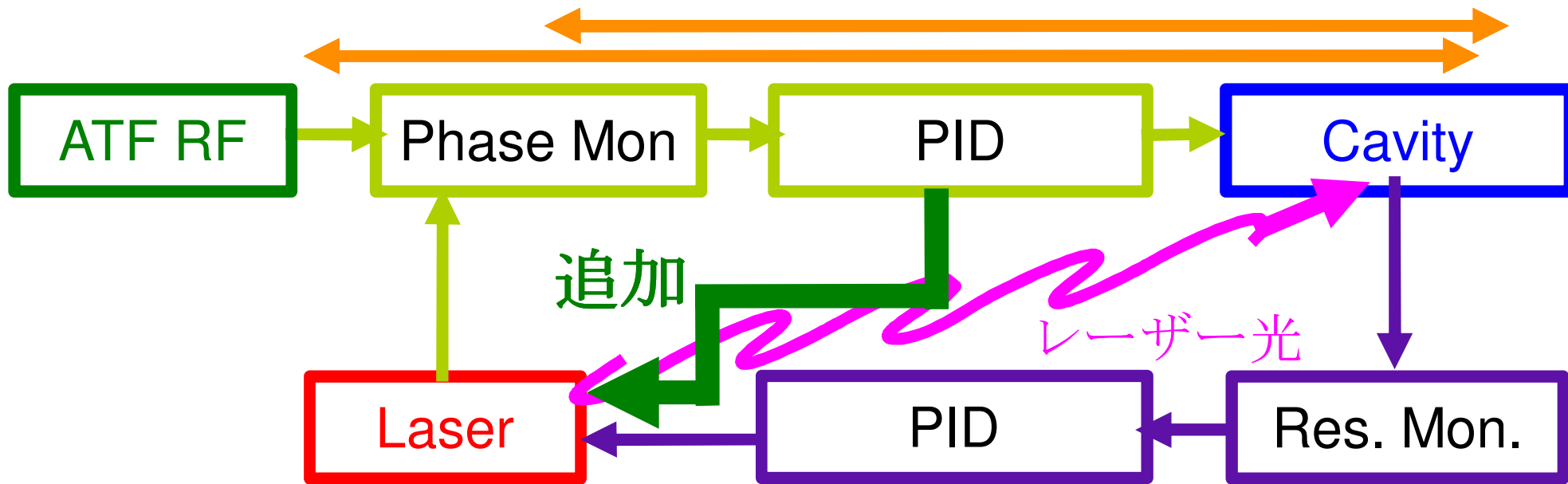

New feedback control
+ improve environment

Timing jitter is now < 2ps

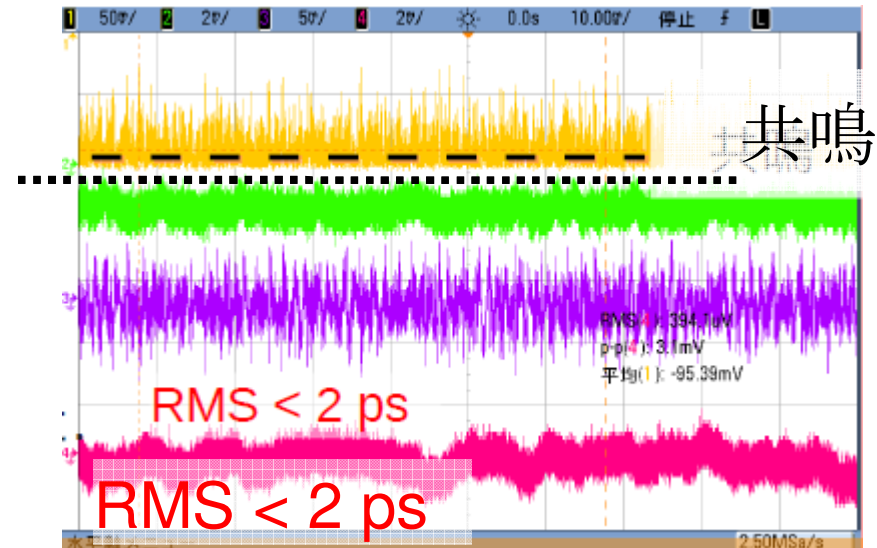

4 MIRROR CAVITY STATUS

March 2009

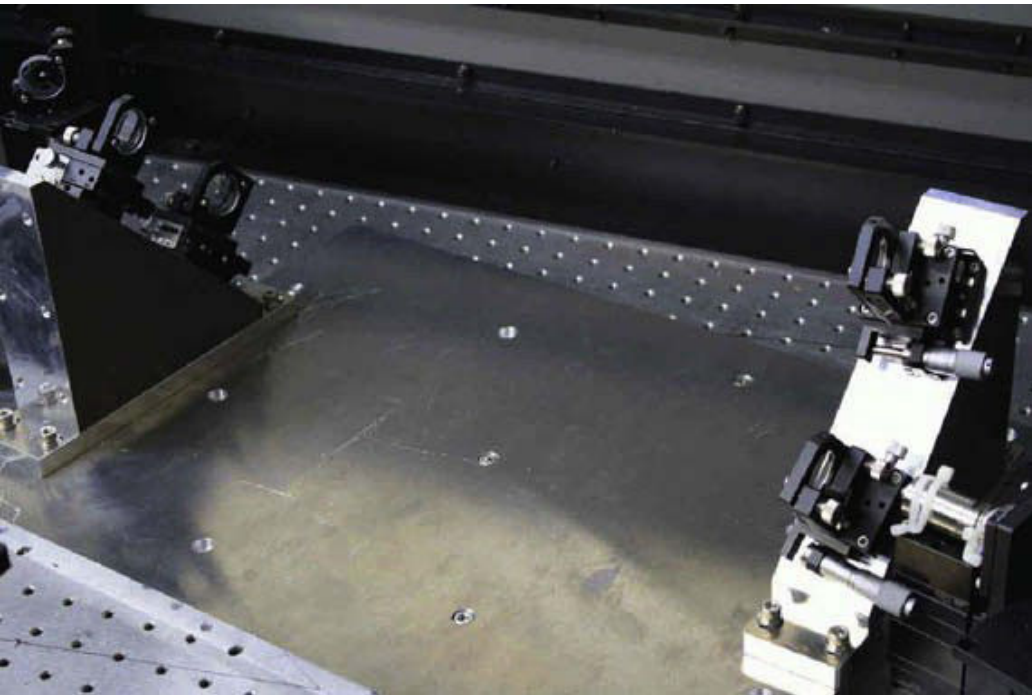

August 2009

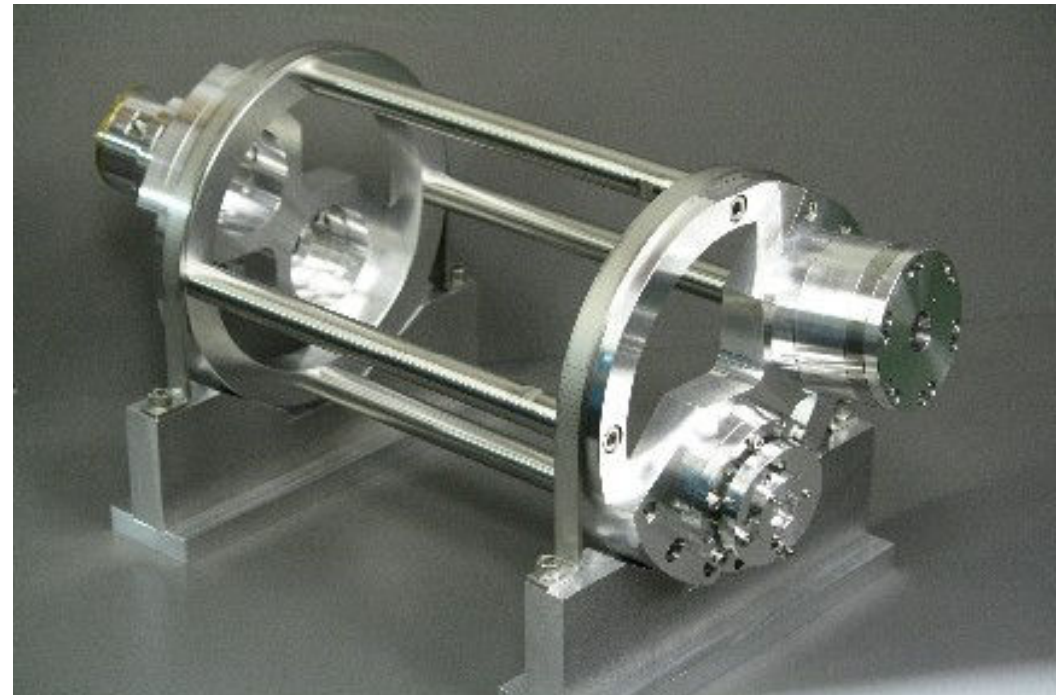

at ALCPG09

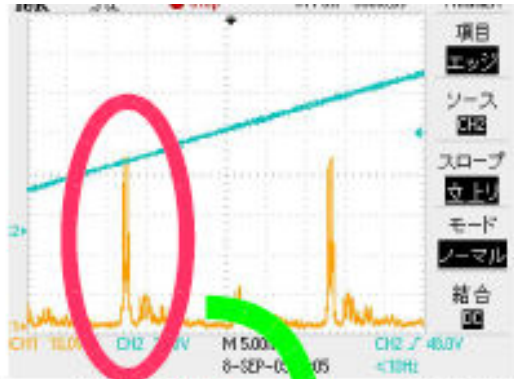

3D 4M cavity resonates with left and right circular polarizations separately

This is due to geometric phase since light travels twisted path

but situation was more complicated

