

EUDET assemblage

- **Thermal Slab assembly sequences**
- **EUDET project : Assemblage**

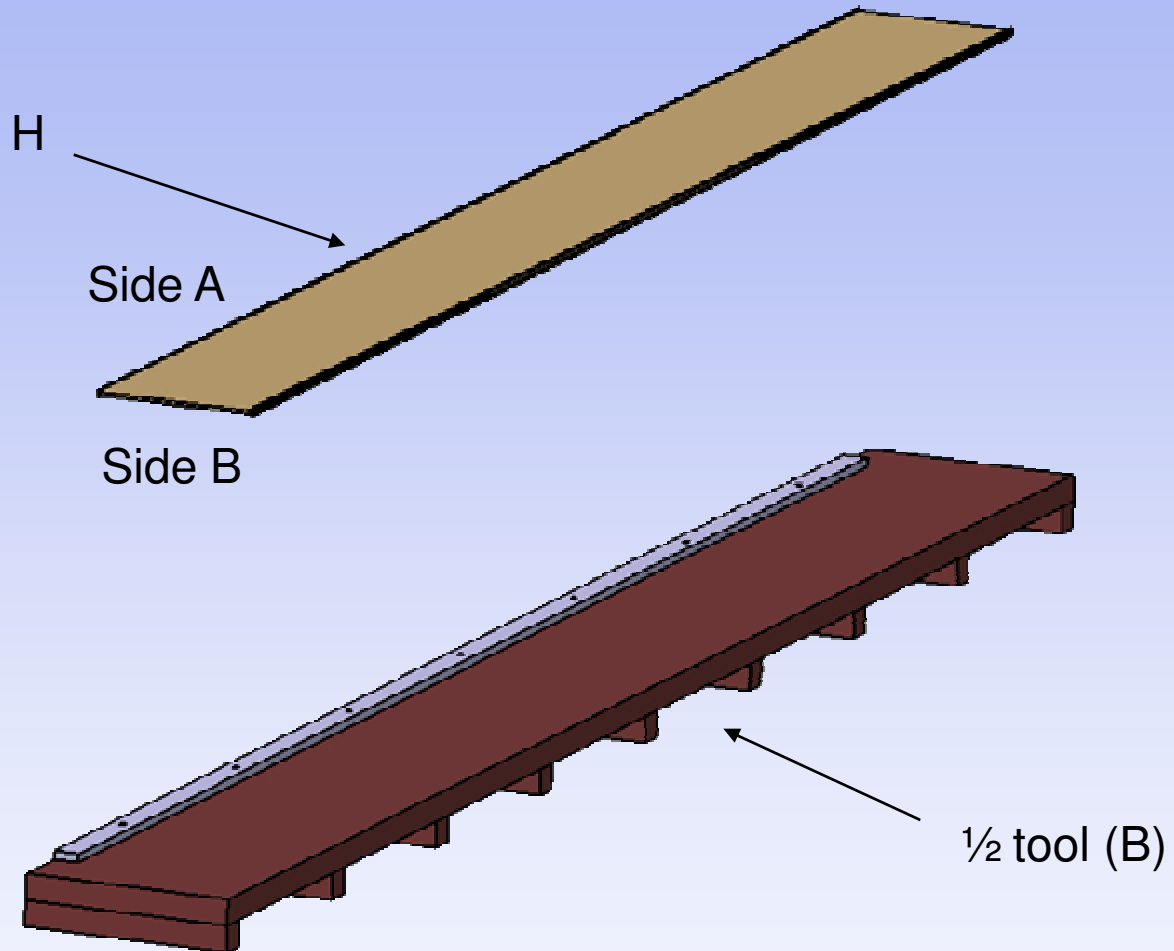

Thermal Slab assembly sequences



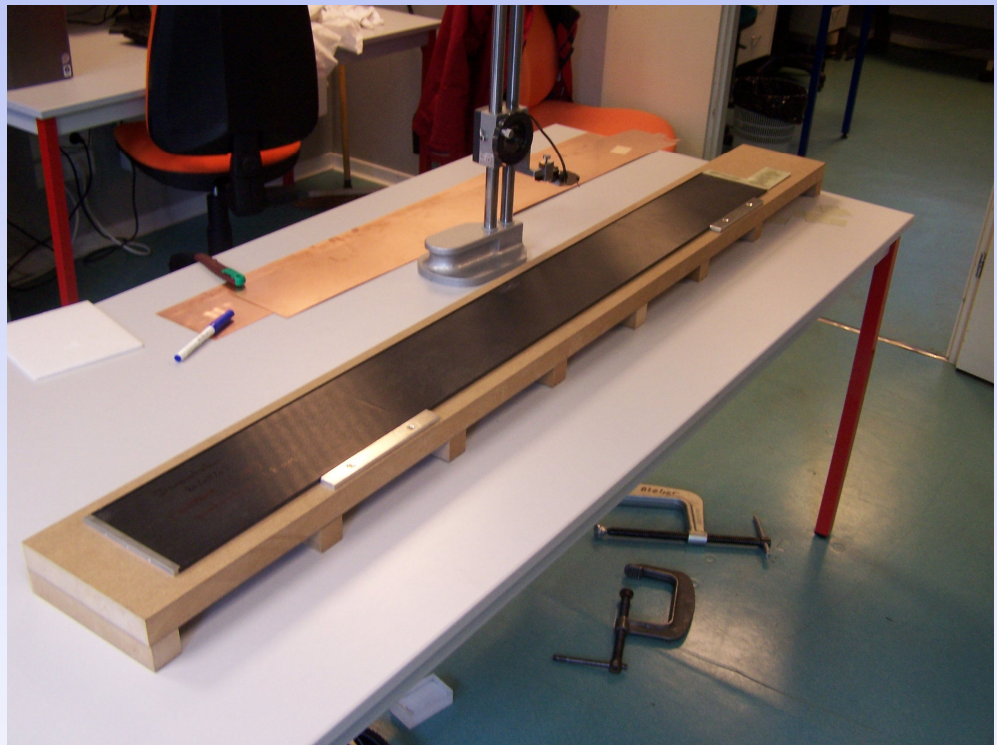
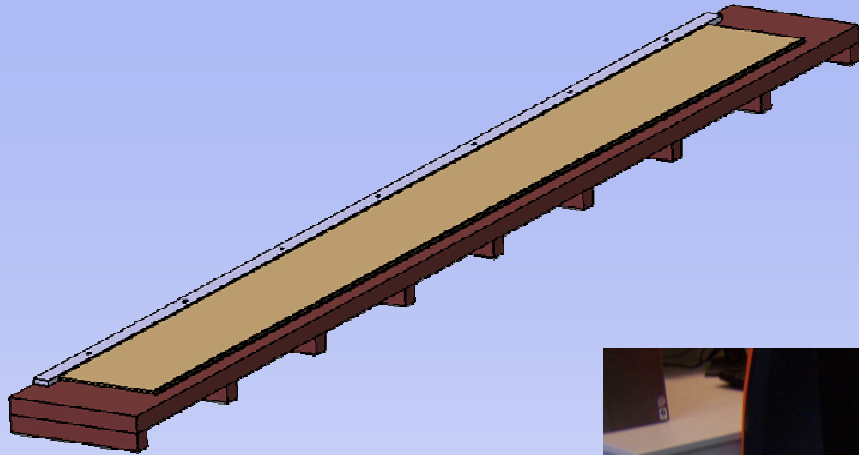

Filling up side A with
Epoxy wedge

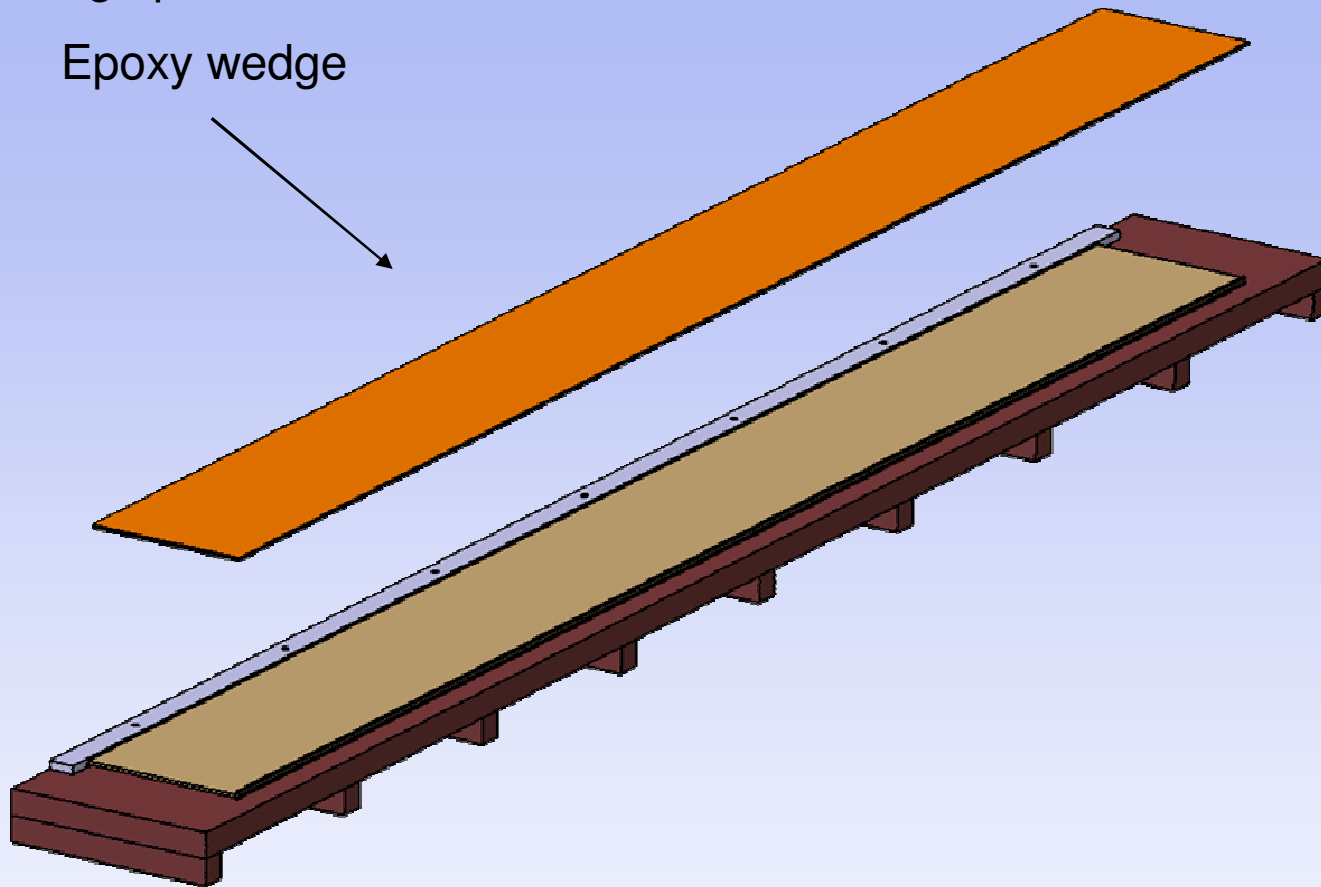

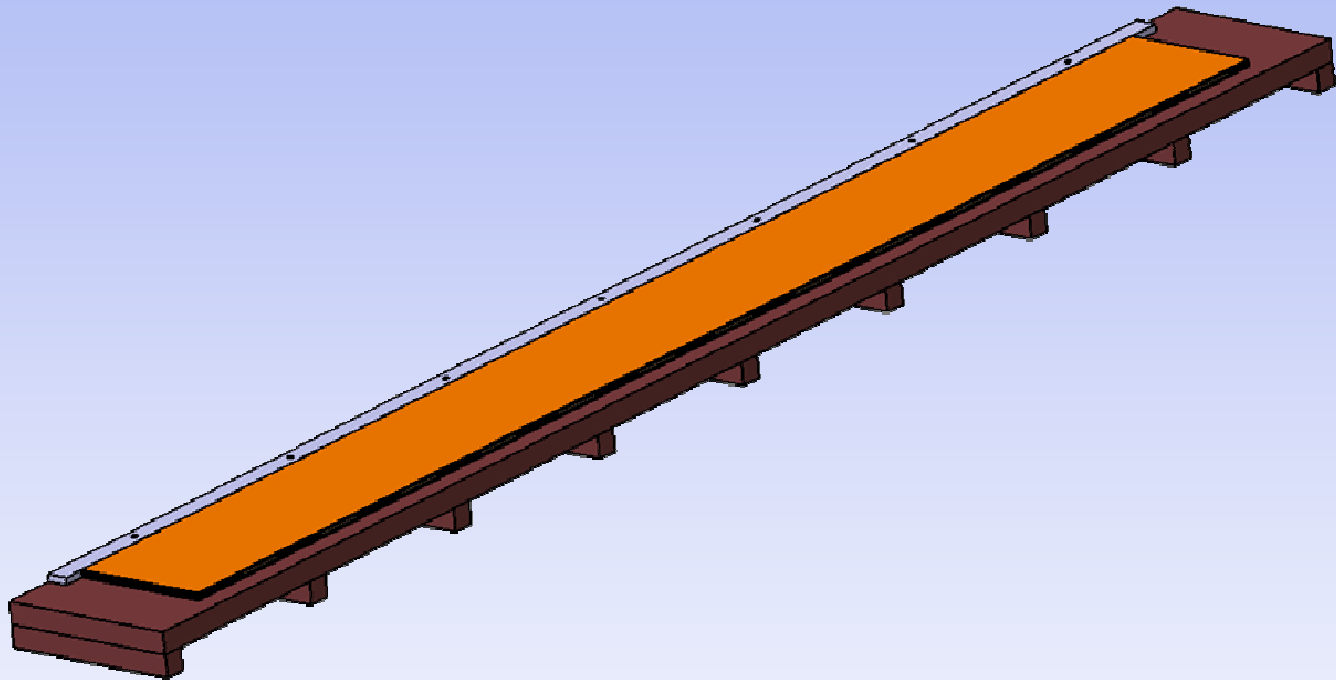

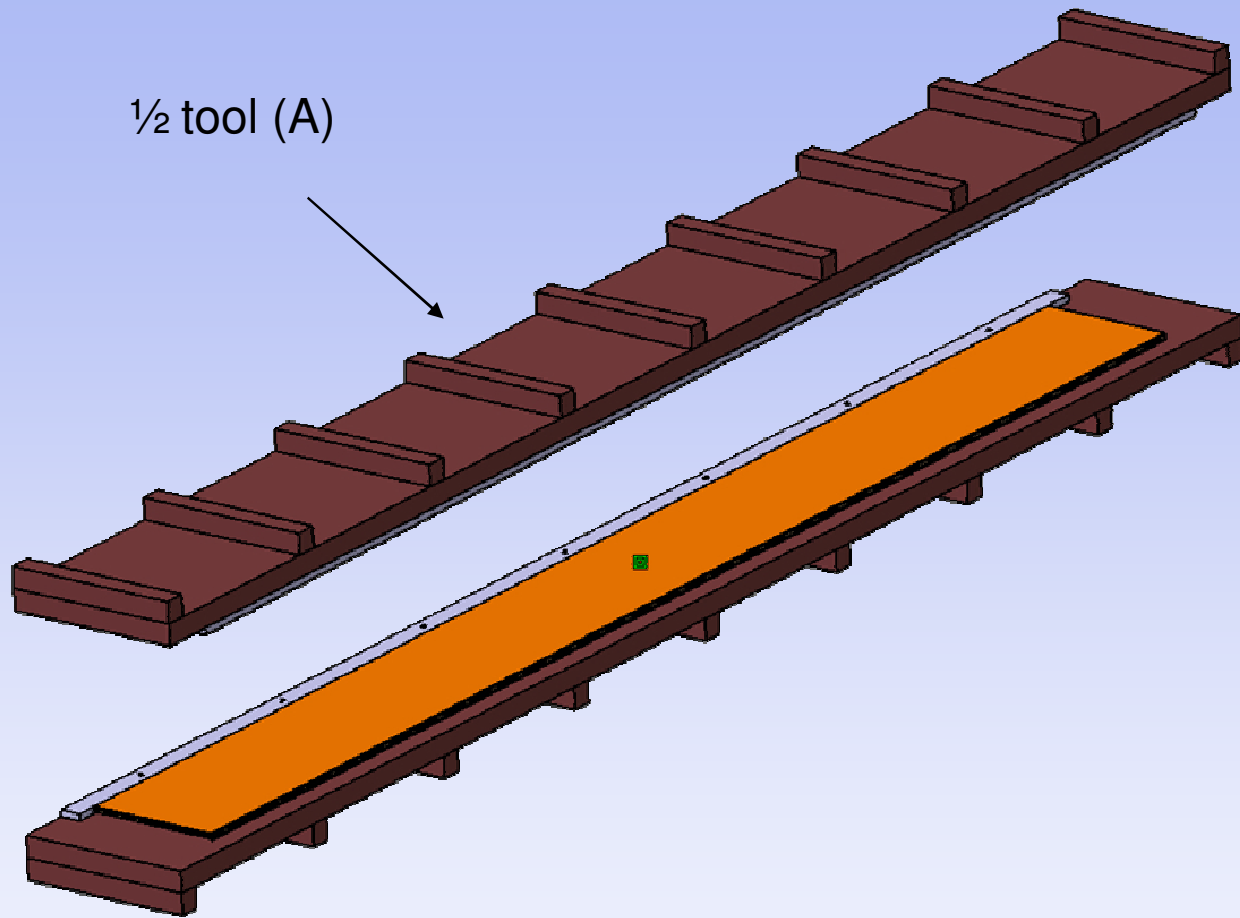

Hold with straps around the two $\frac{1}{2}$ tools

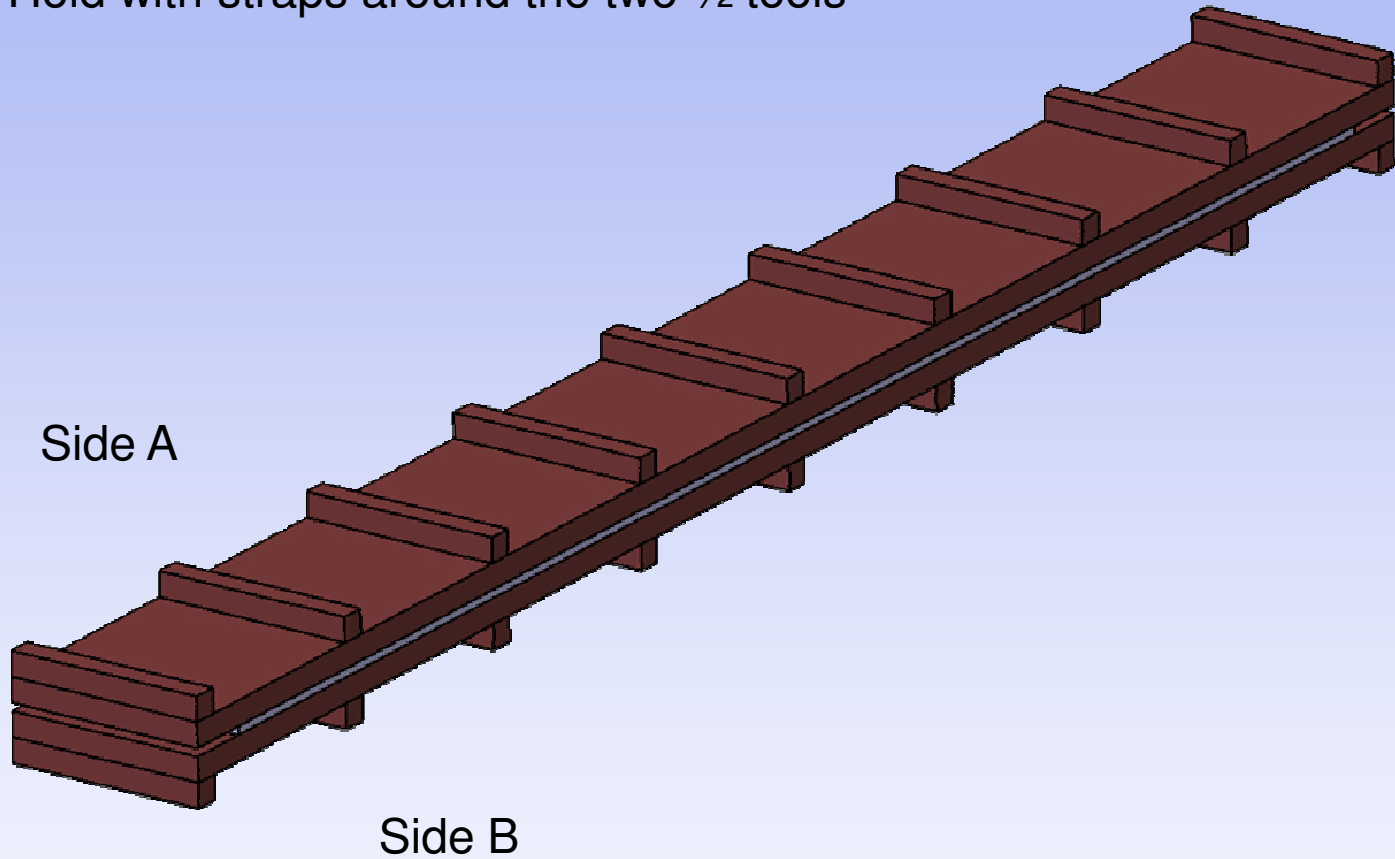

Resersal by hands

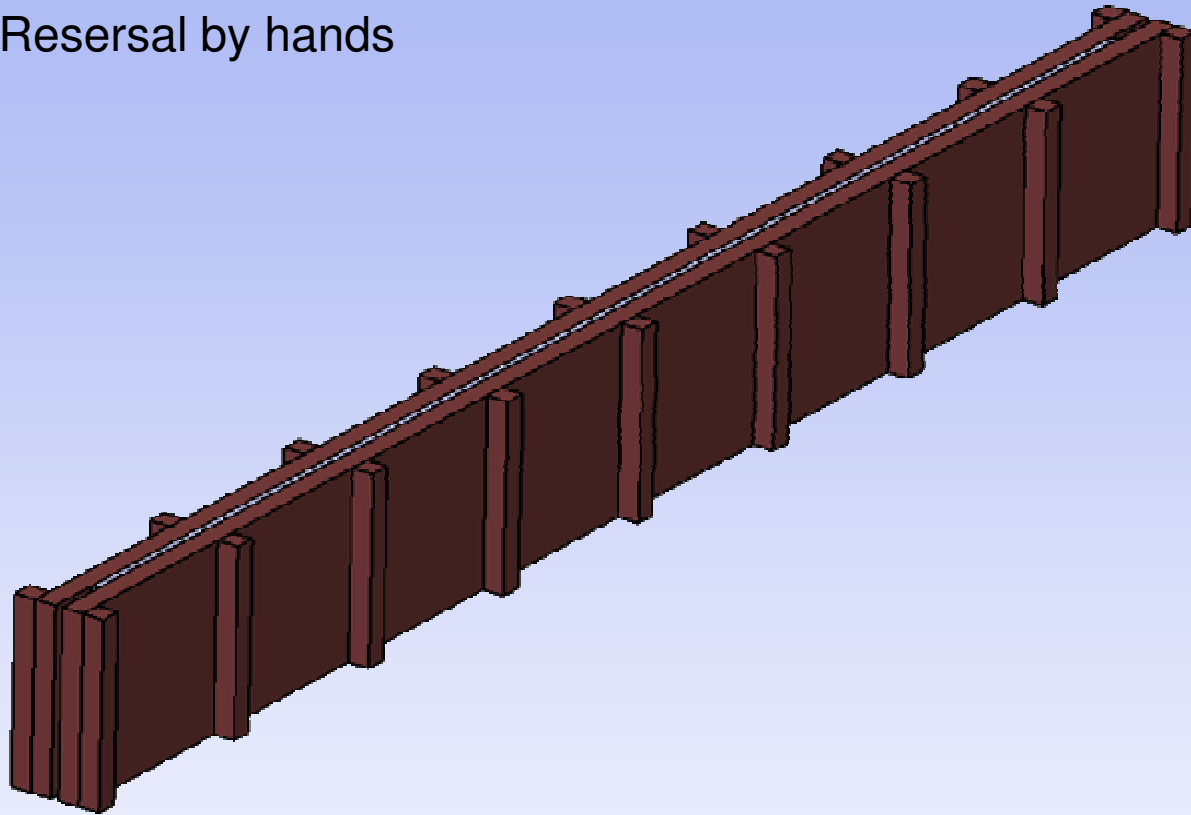

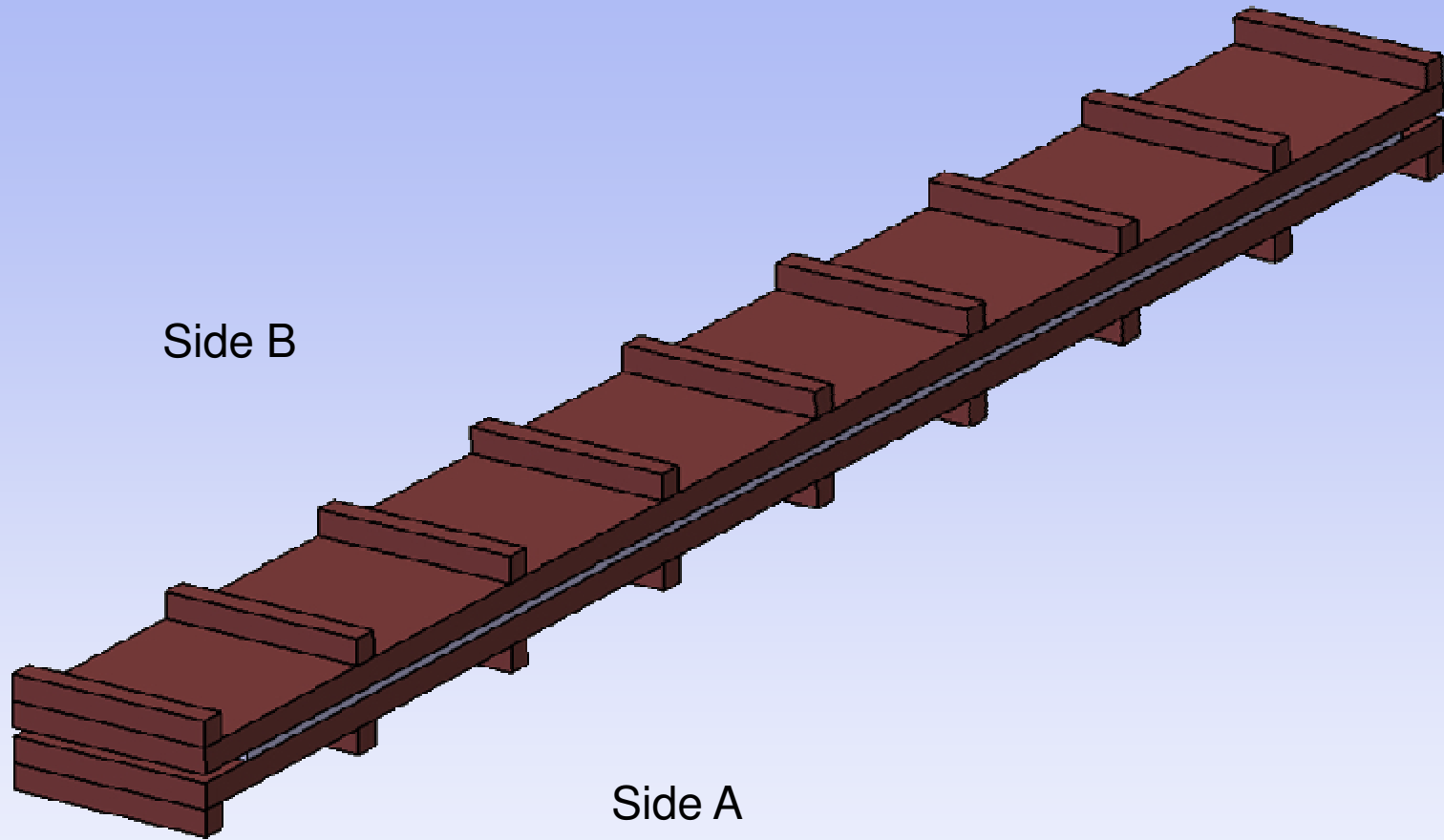

Opening side B

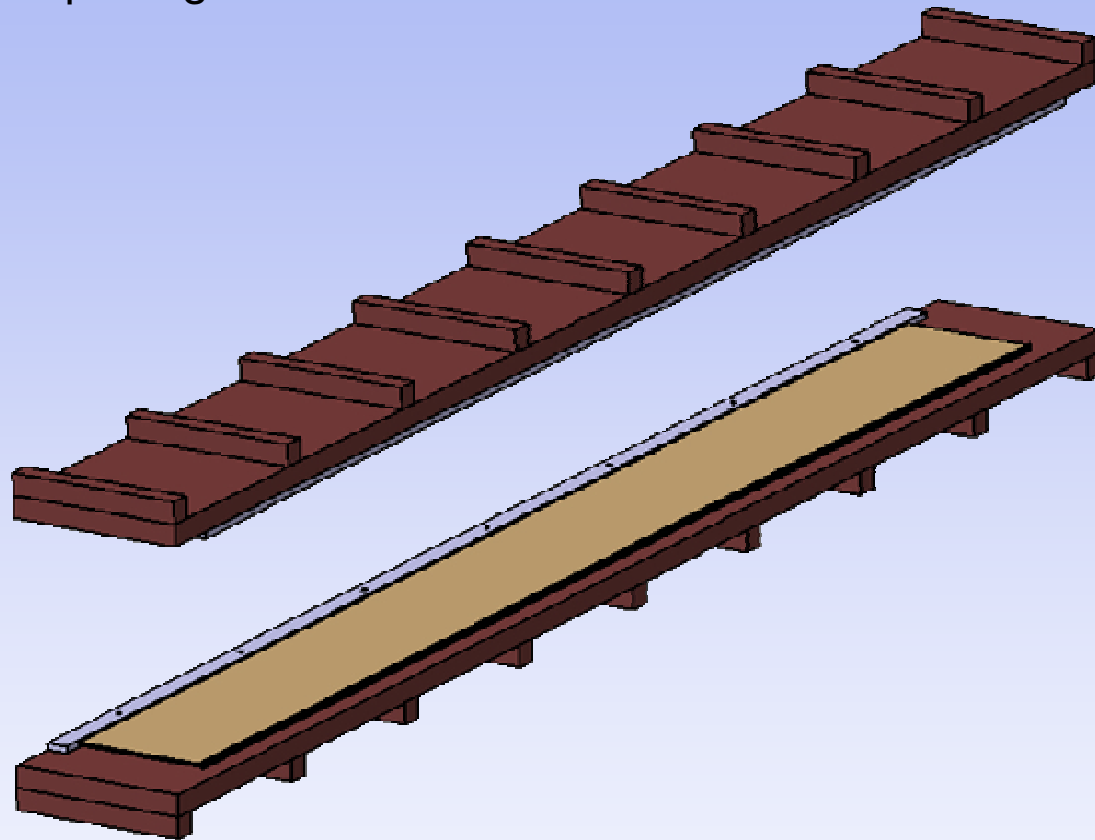

Filling up side B
With thermal ASU
and copper drain

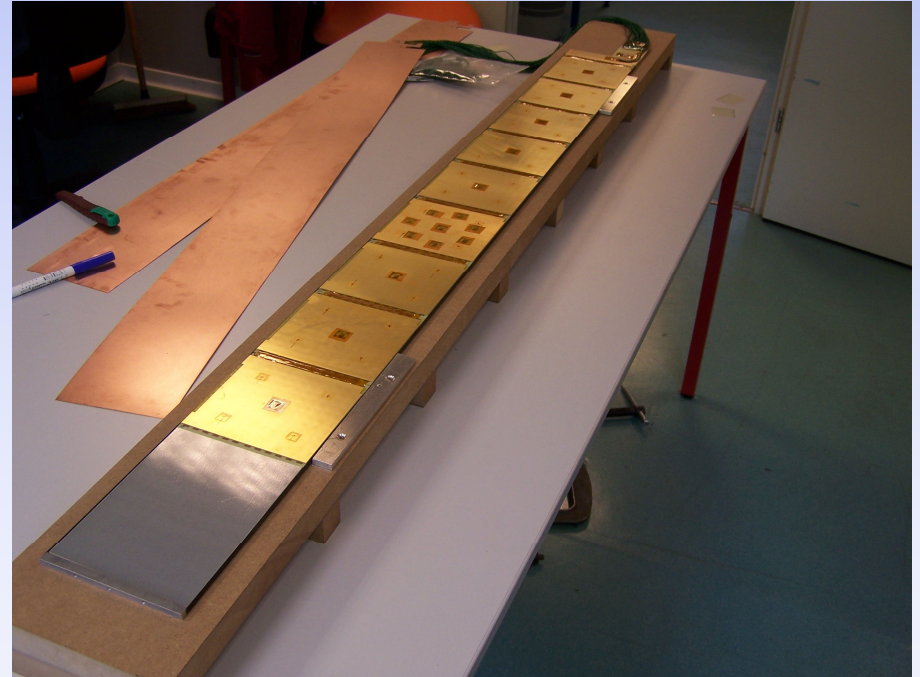
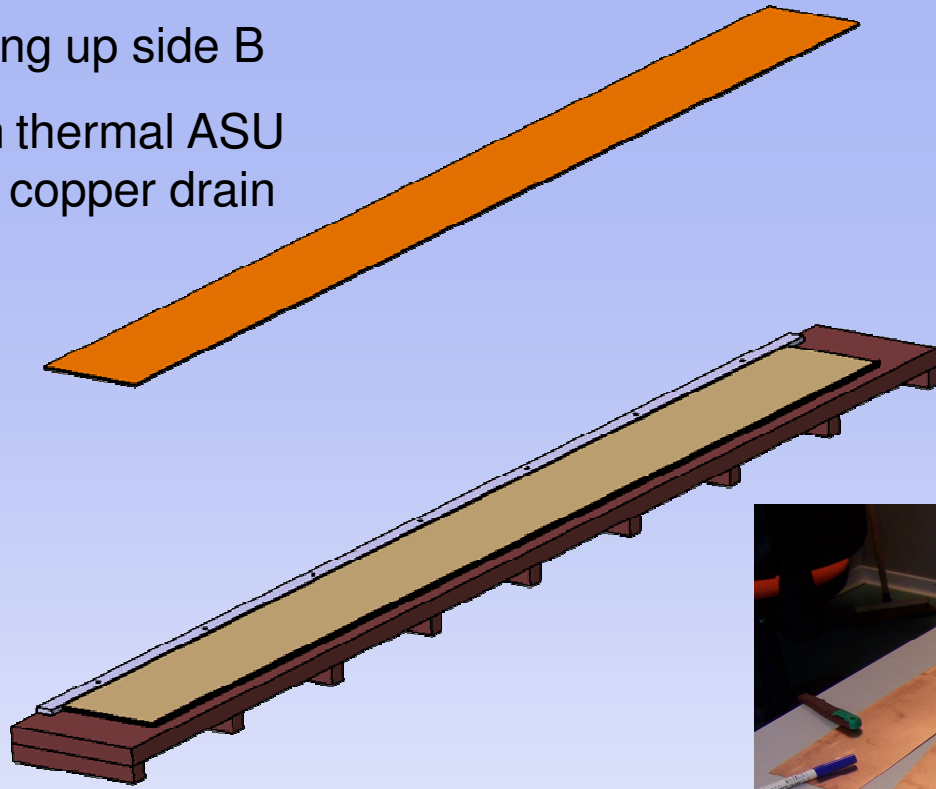

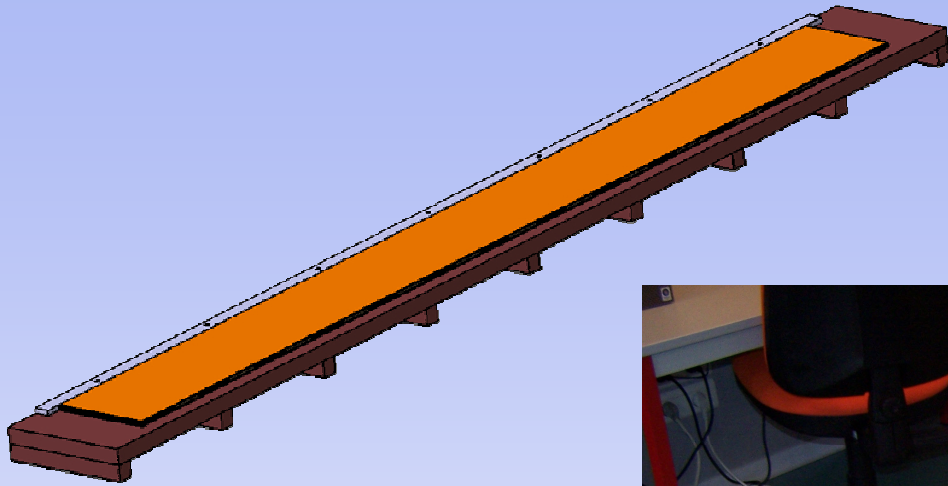

Janvier 15, 2010

LLR EUDET meeting

12

Slab slip on side to clamp the edge (I) with copper tape (specific modified tape driver).

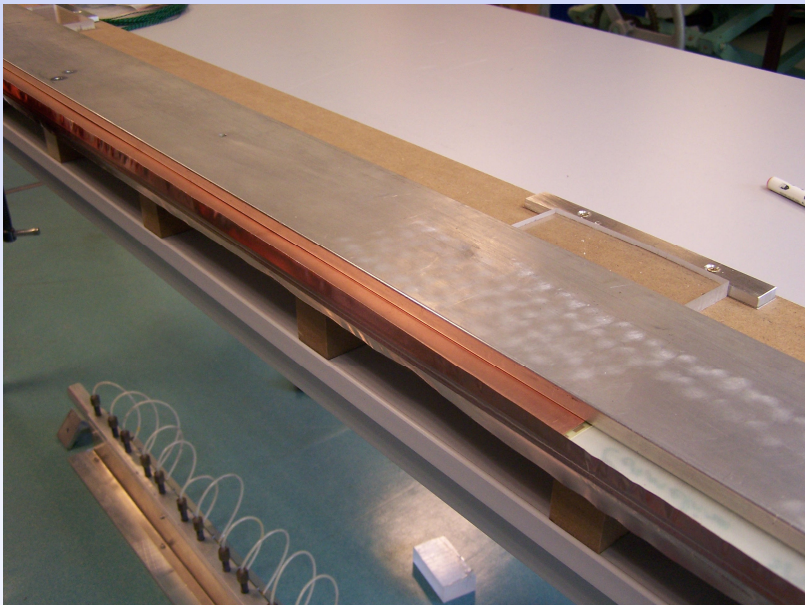
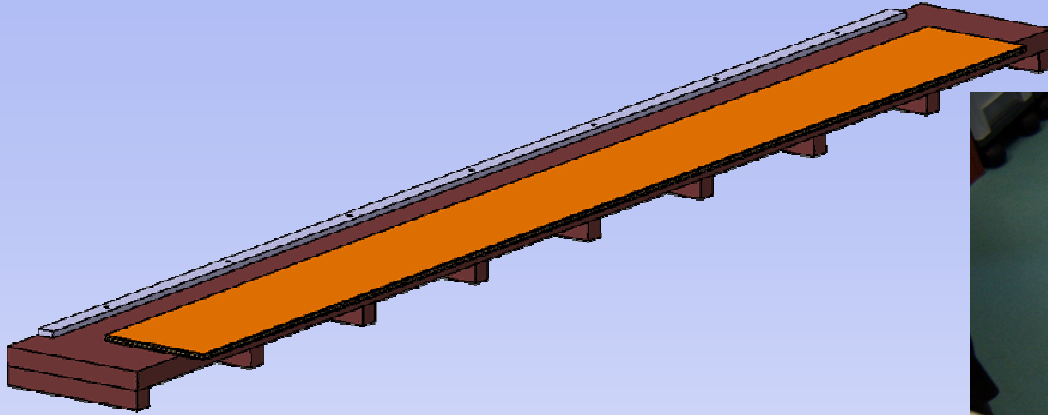

Slab slip in initial position

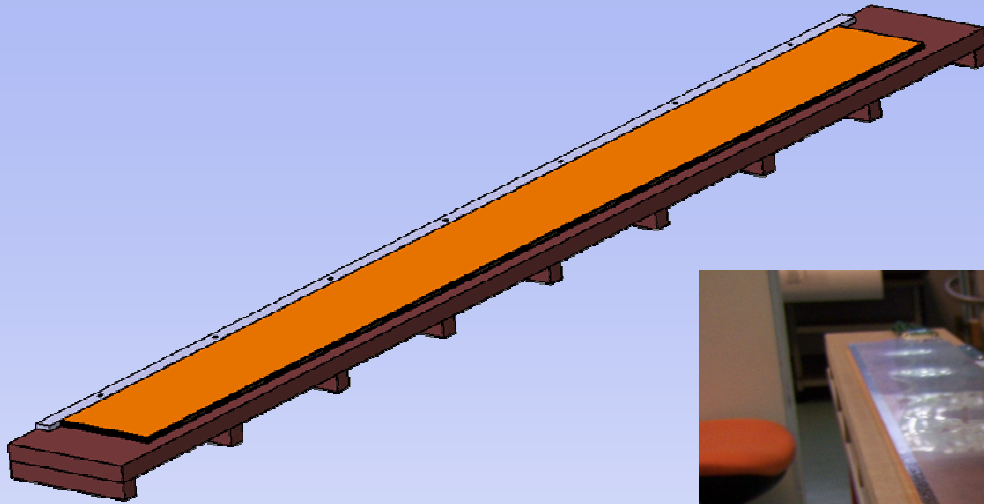

Close with 1/2 tool (B)

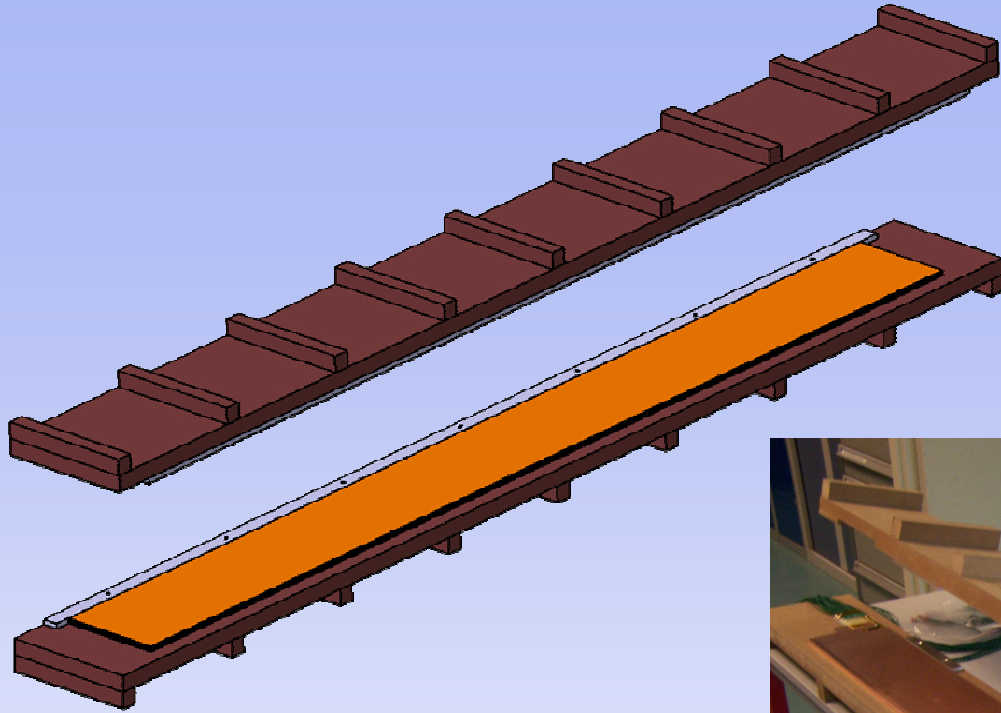

Hold with straps around the two $\frac{1}{2}$ tools

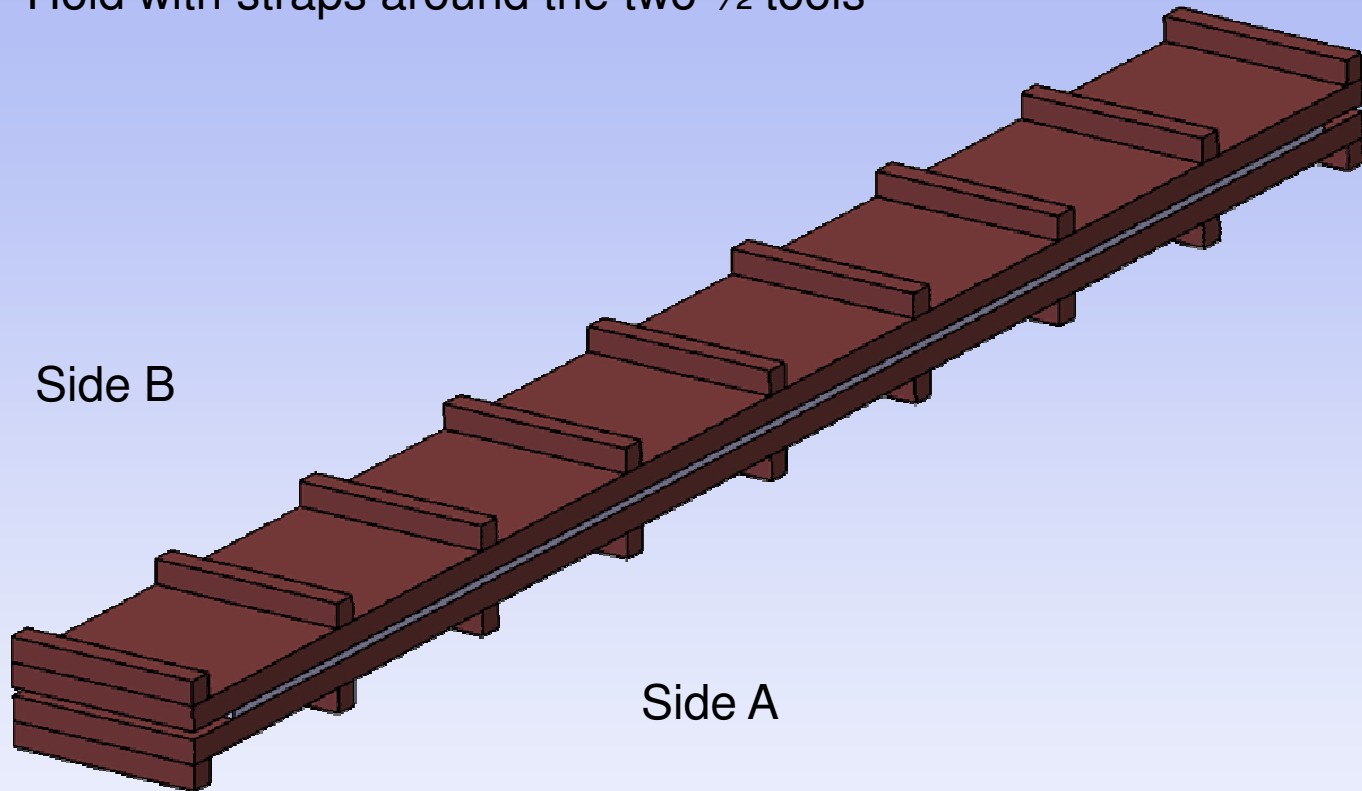

Side B

Side A

Resersal by hands

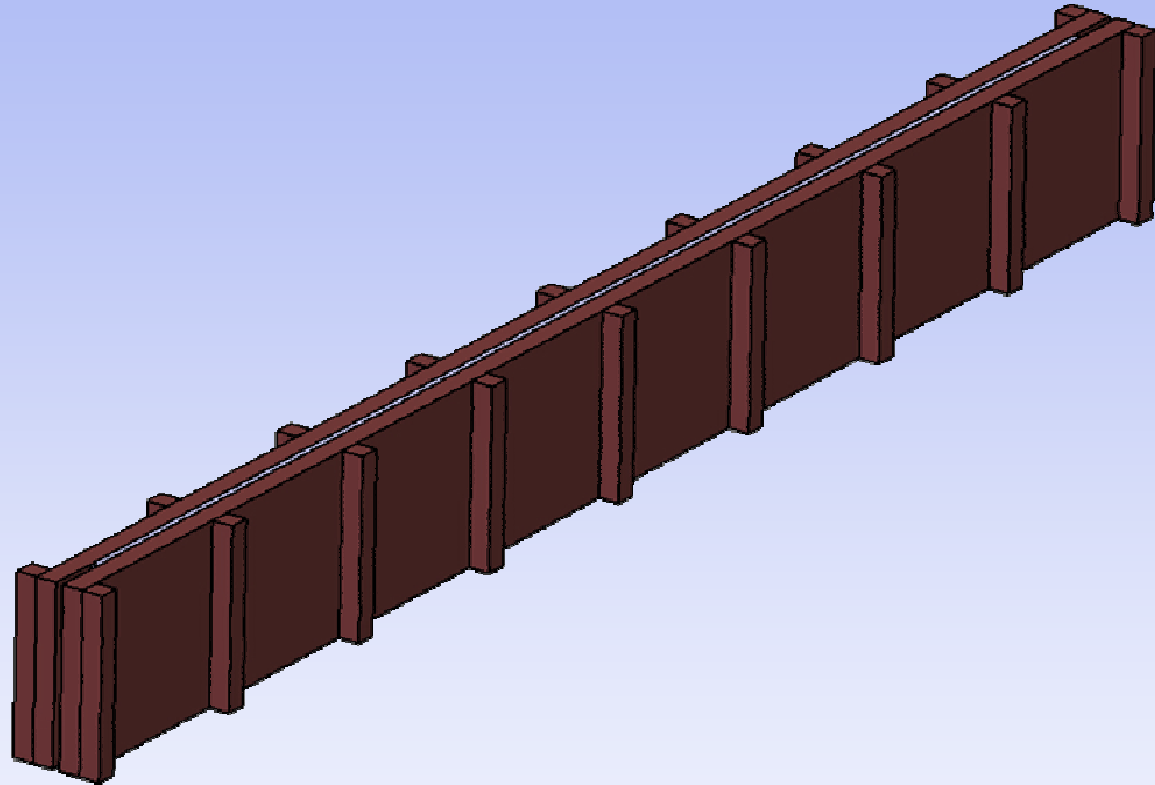

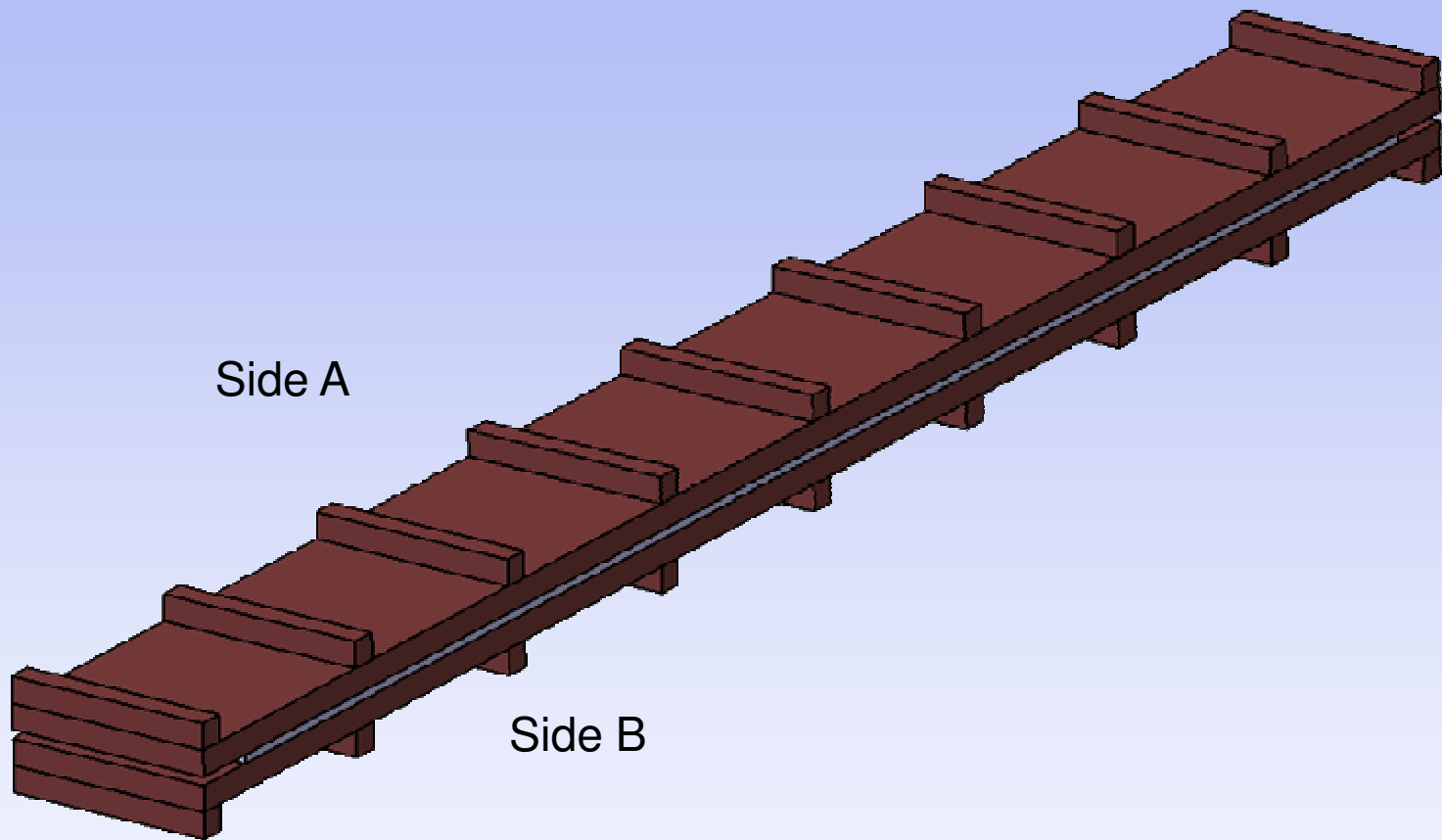

Opening side A

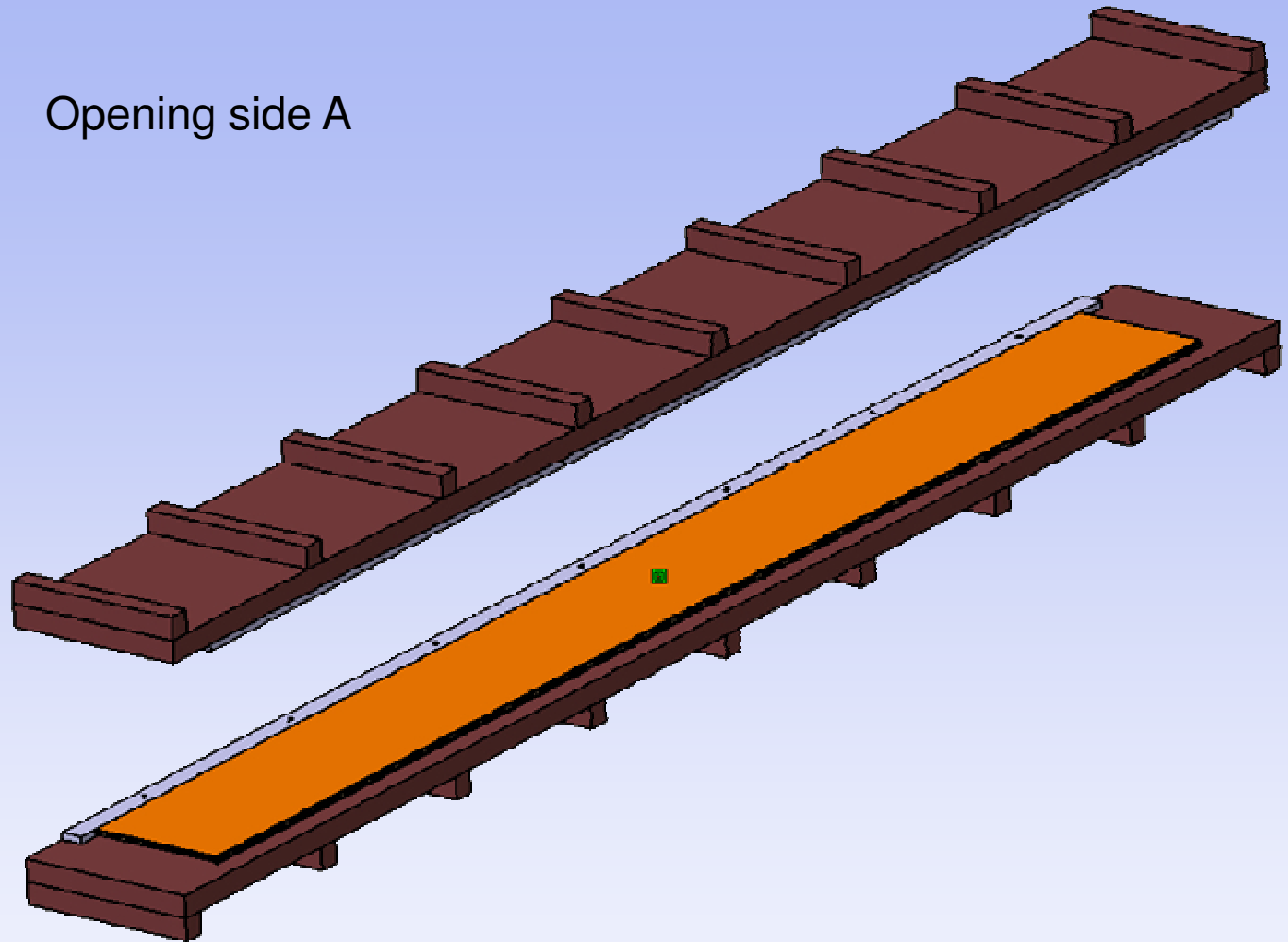

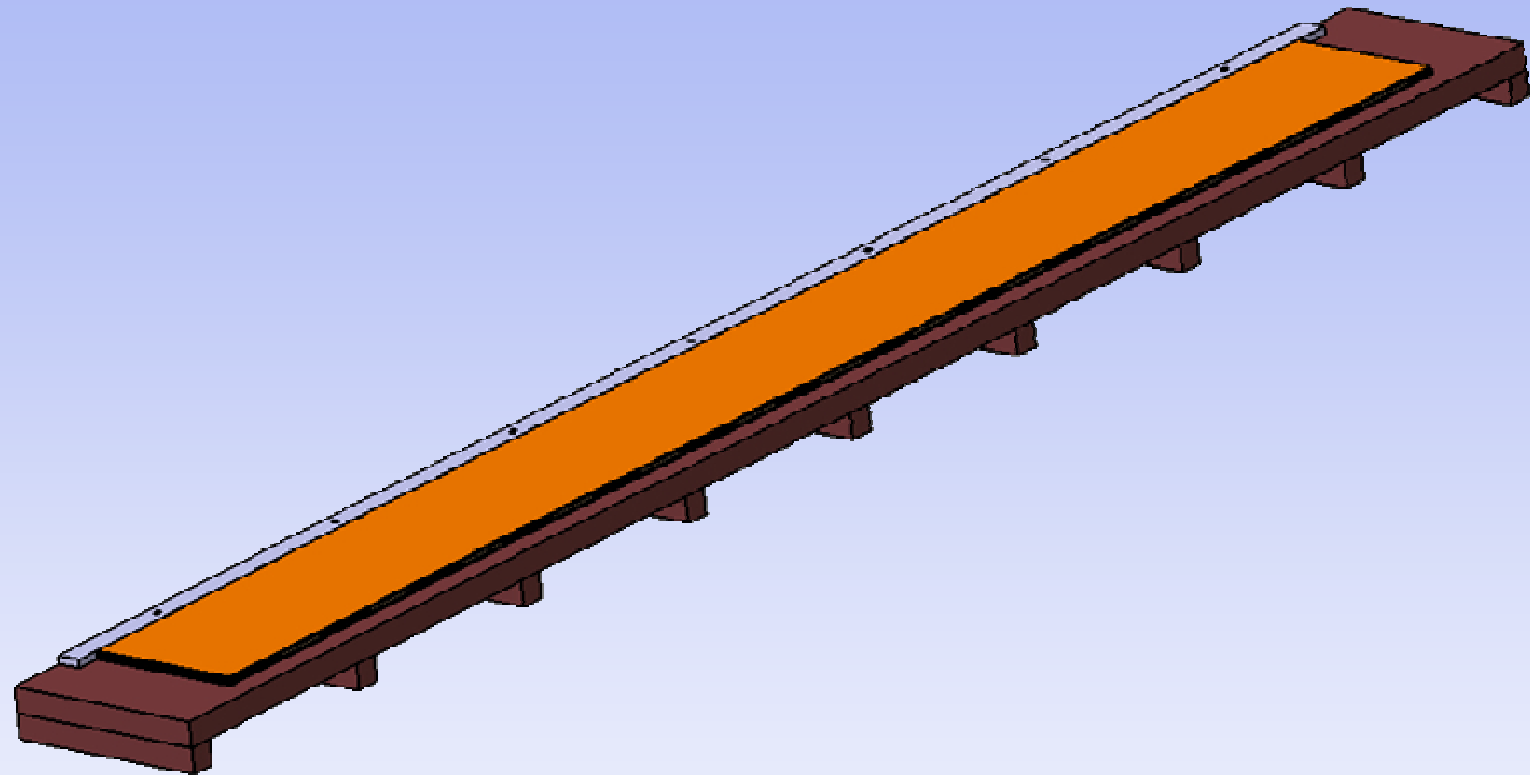

Slab slip on side to clamp the edge
(II) with copper tape

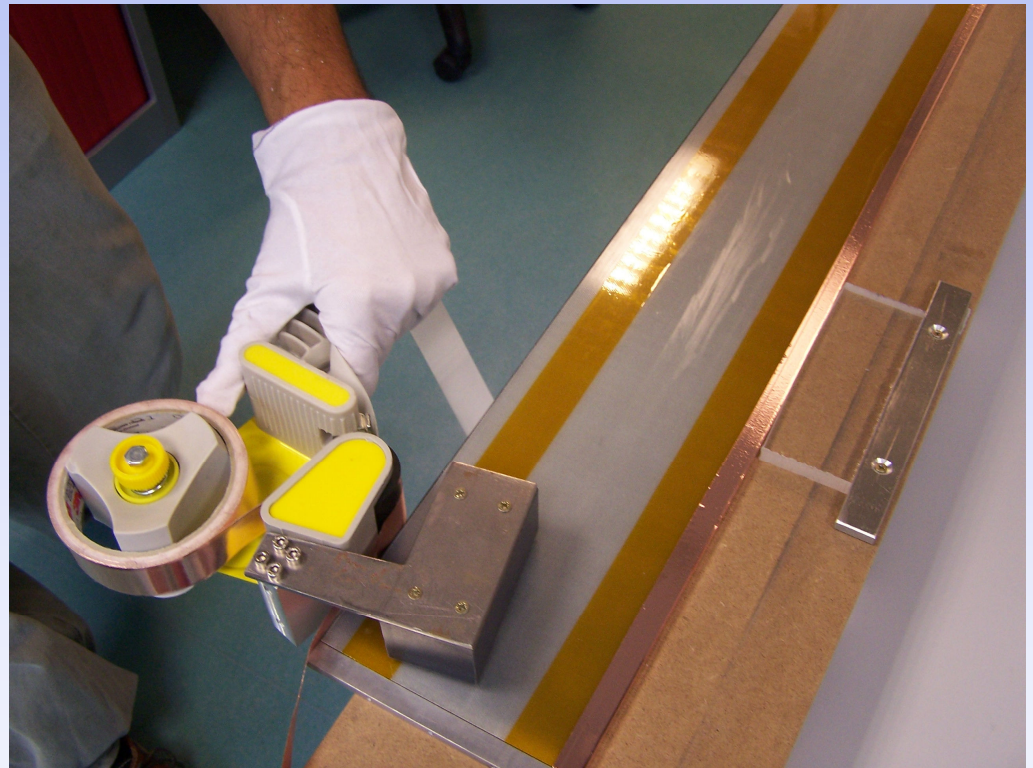
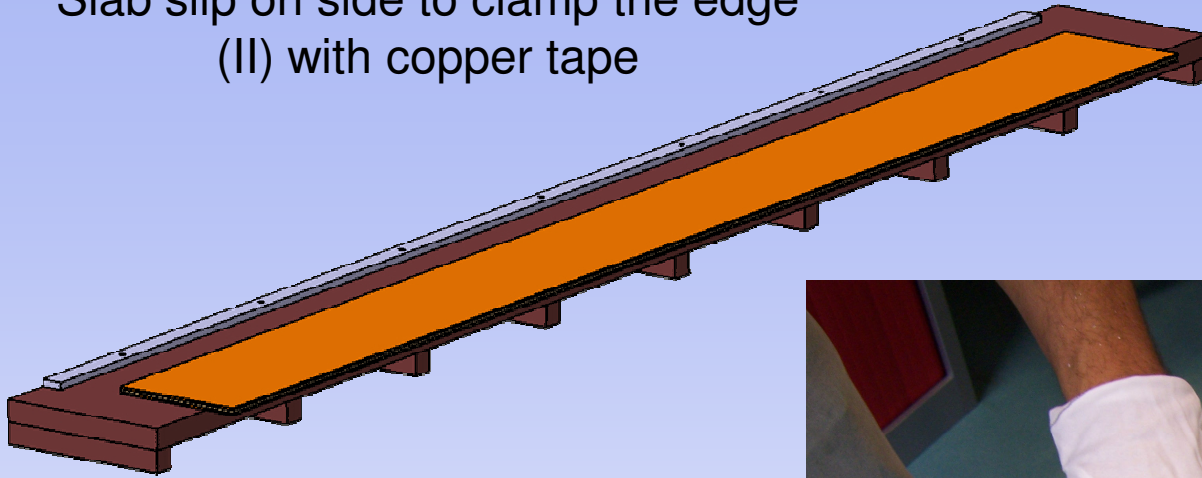

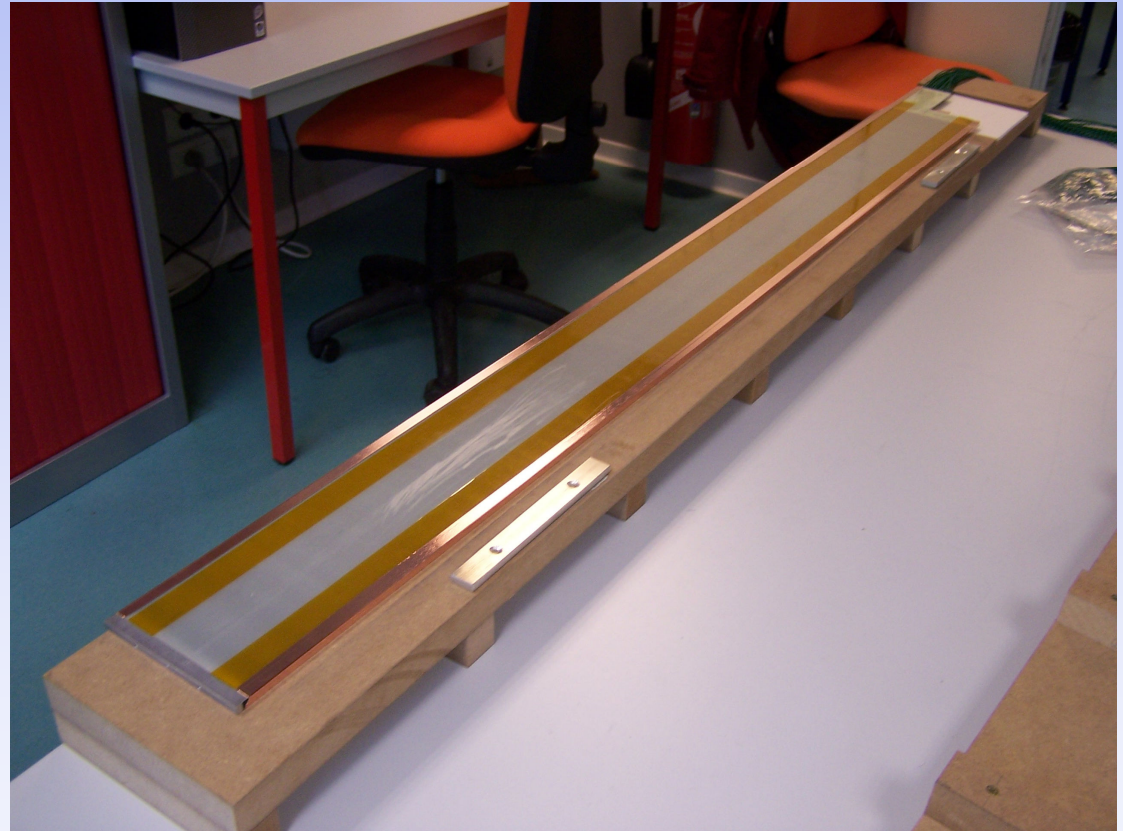
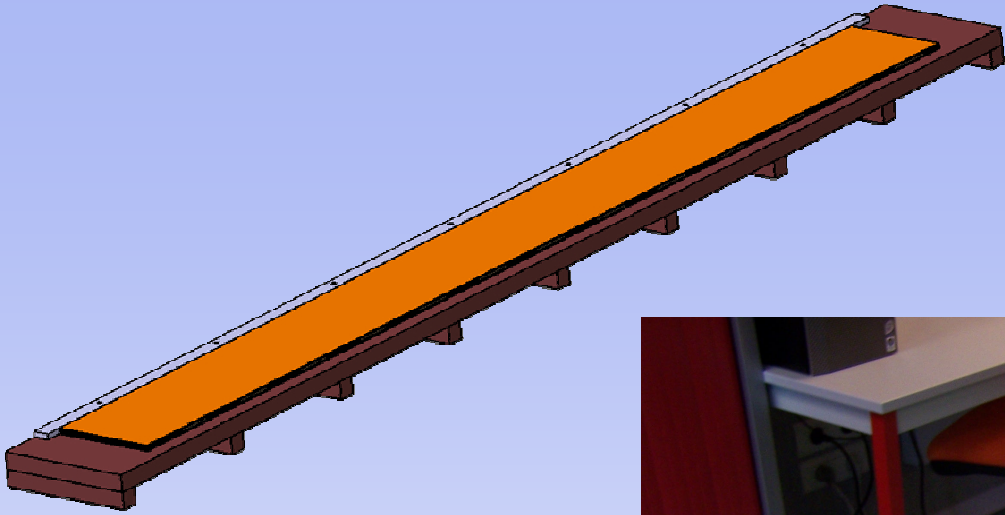

Janvier 15, 2010

LLR EUDET meeting

22

Close side A

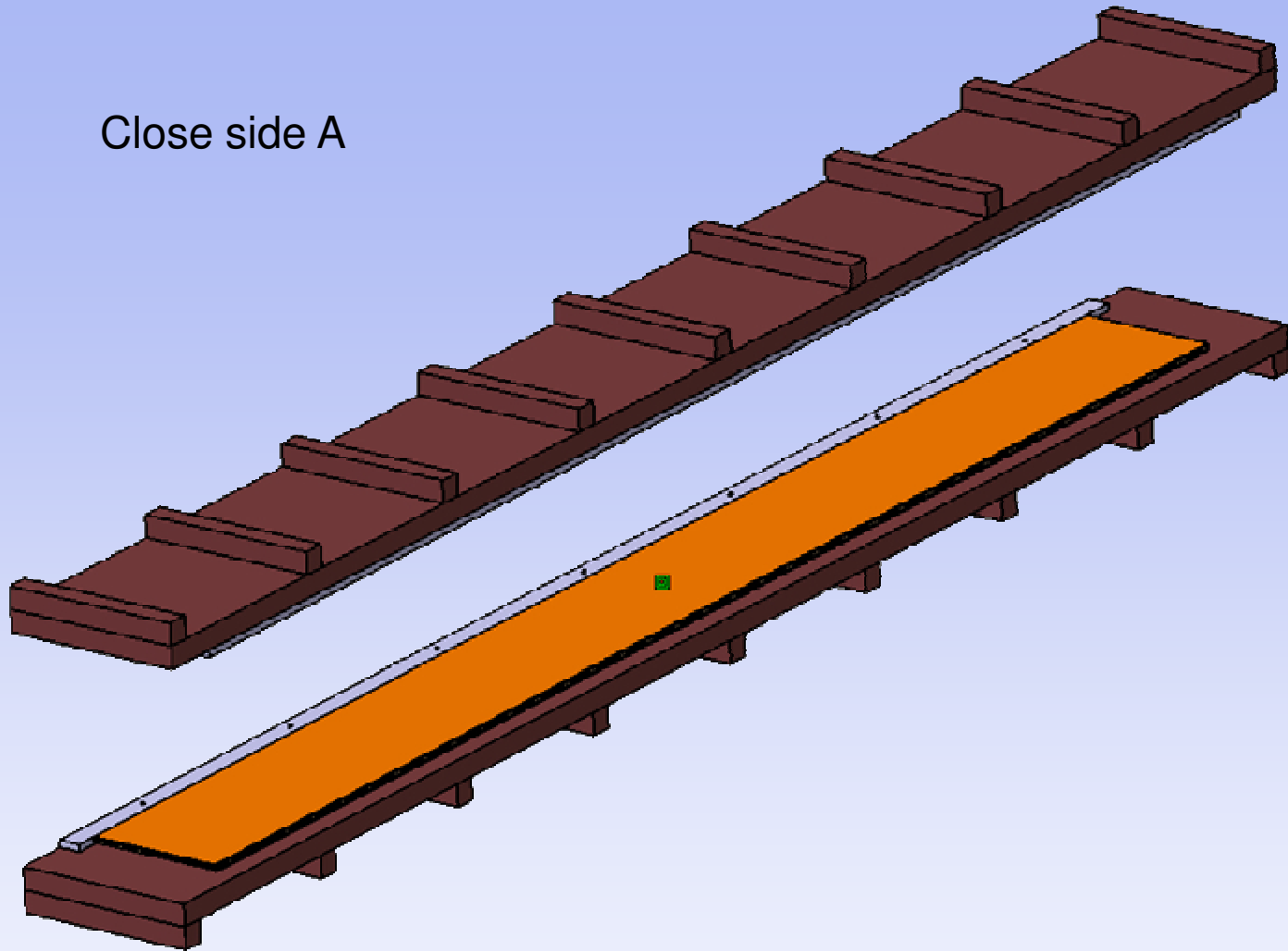

Hold with straps around the two 1/2 tools

= Storage box

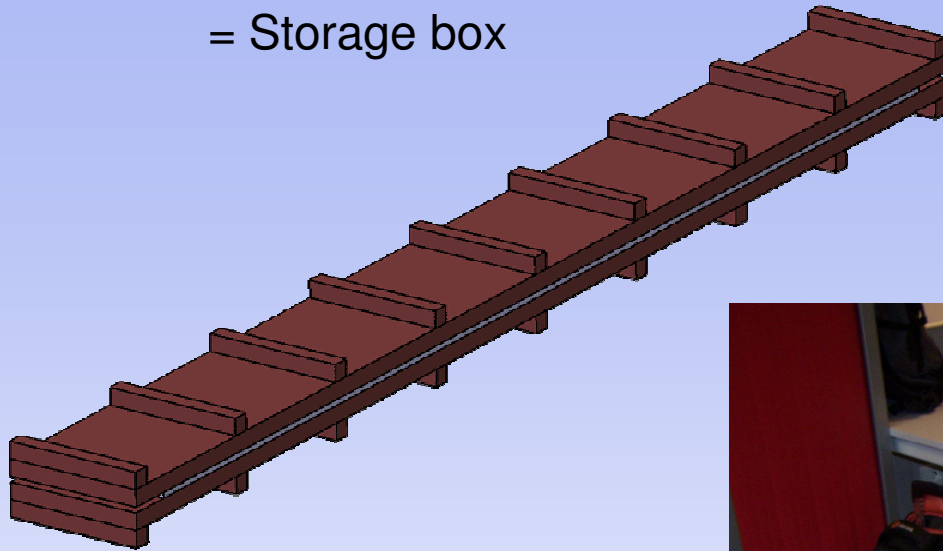

Finish thermal Slab in Tool

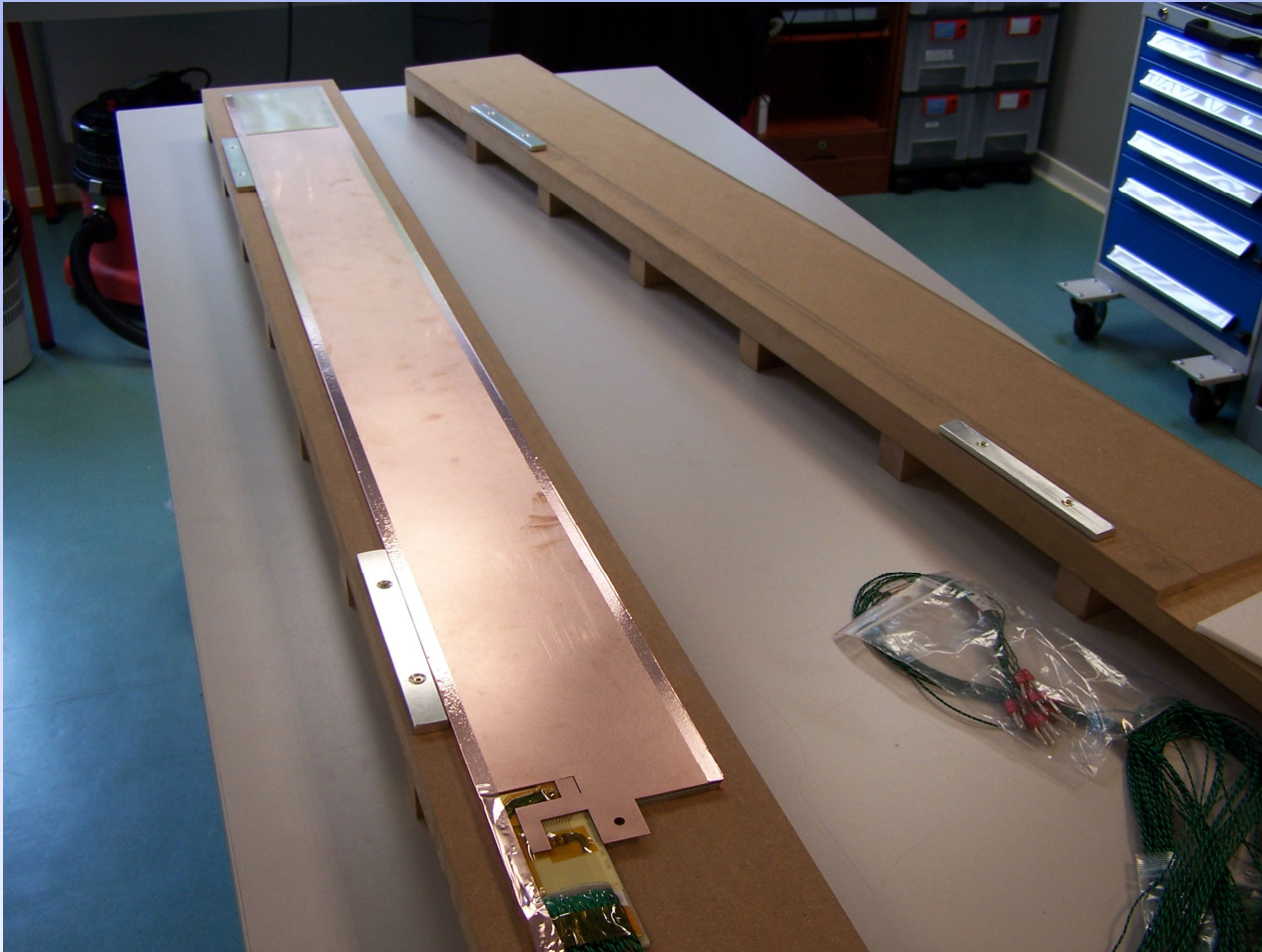

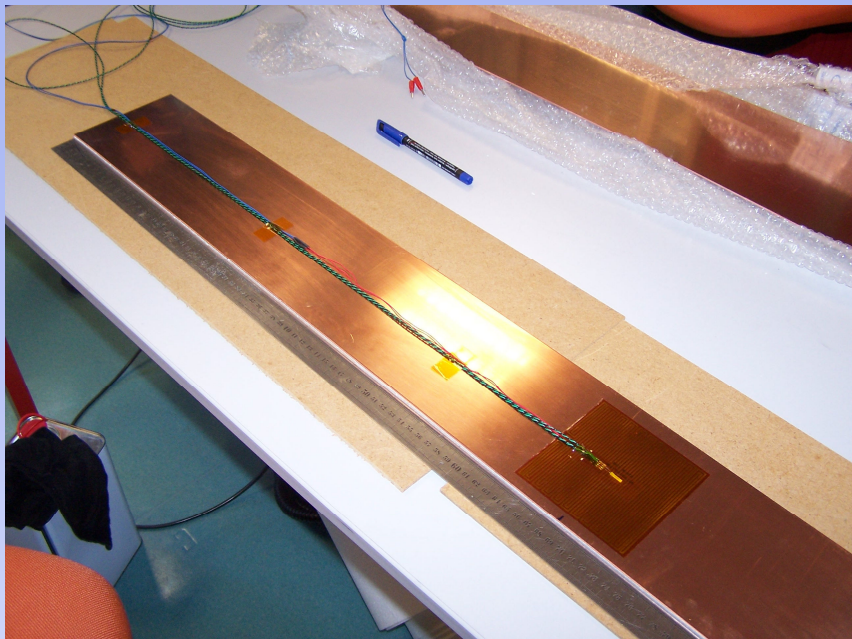

Equivalent heating thermal Slab
(without H tungsten structure)

Heating kapton pad
and
PT 100 sensor

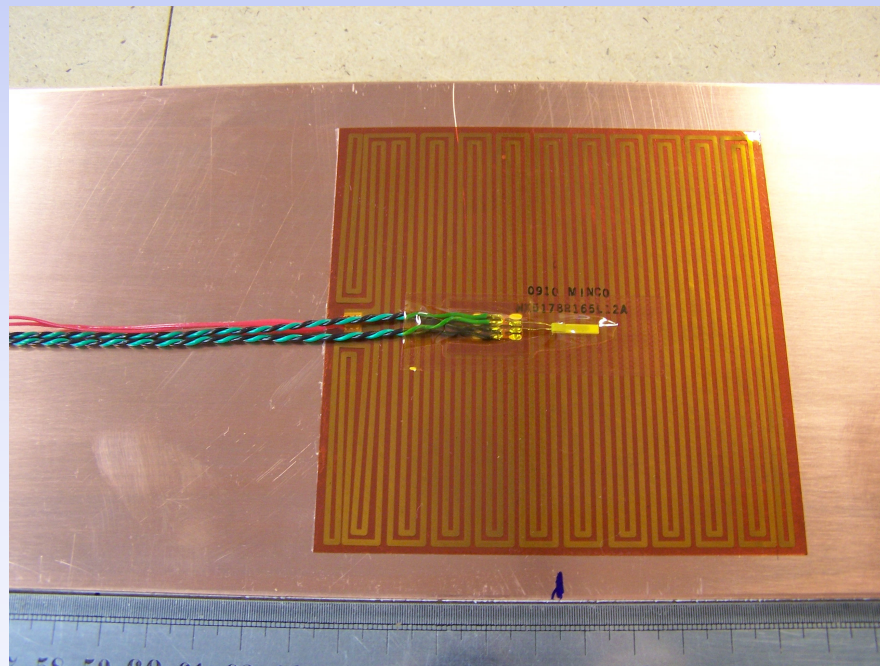



2 mm copper
+
4 mm polystyren

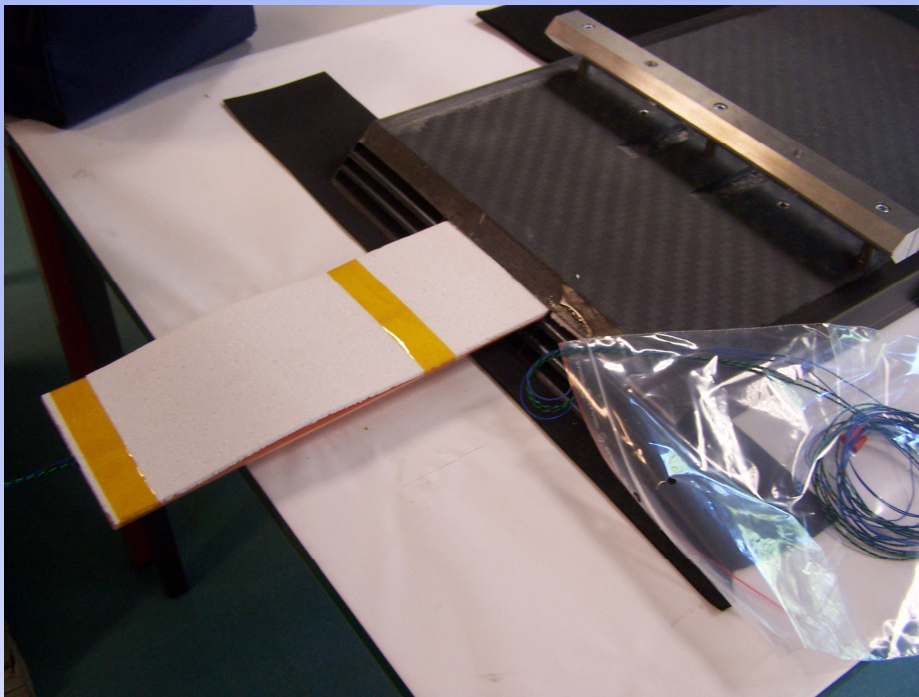

Equivalent heating thermal Slab during integration in structure

Equivalent heating thermal Slabs in structure

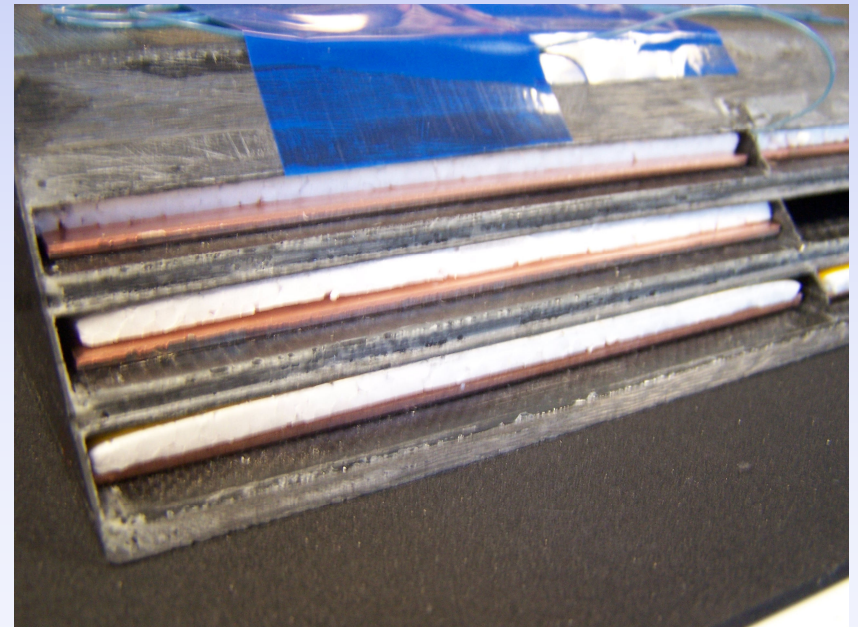

Overview of equipped test structure

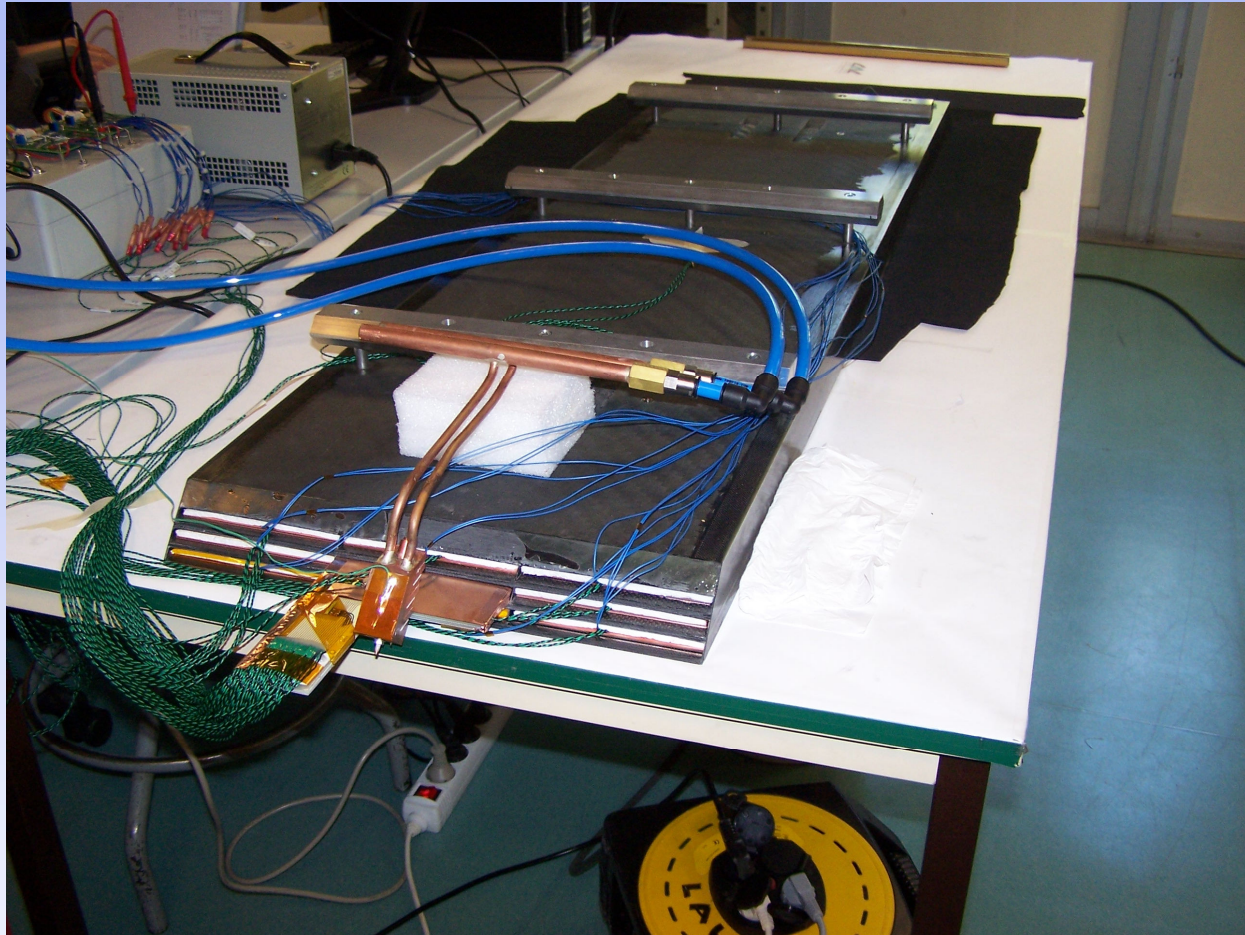

EUDET project

Assemblage

