

Cavity Field Control

- Cavity Theory

LLRF Lecture Part 3.1

S. Simrock, M. Grecki

ITER / DESY

A horizontal dotted line in a light yellow-green color is located at the bottom of the slide, mirroring the one at the top.

- Introduction to the Cavity Model
- Baseband Equations for Cavity Model
- Driving Term in Cavity Equations
- RF Power Dissipation and Reflection of a Cavity
 - RF Power Dissipation and Reflection at Filling Stage
 - RF Power Dissipation and Reflection at Flattop Stage
- Mechanical Model of the Cavity
- Pass Band Modes of the Cavity
- Cavity Simulator

Introduction to the Cavity Model

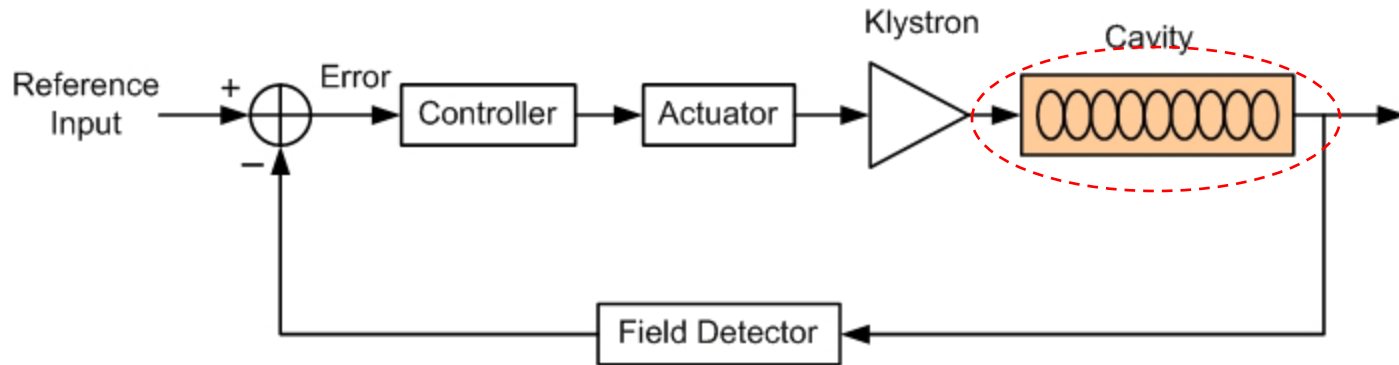

The cavities are the plant to be controlled by the LLRF system.

The cavities are driven by the RF power amplifiers such as klystron.

Normally, the cavities are equipped with probes for picking up the RF signal to be measured by the field detector.



Motivation for Cavity Model Study

- Understand the property and behavior of the cavity
- Model the cavity and the LLRF control system for algorithm study and controller design

9-Cell Cavity



Working
Mode:
TM010

Parameters
for TESLA
cavity

Effective length	1036 mm
Aperture diameter	70 mm
Cell to cell coupling	1.98 %
r/Q	1036 Ω
Unloaded Q0	$\approx 10^{10}$

Equivalent RLC Circuit Model

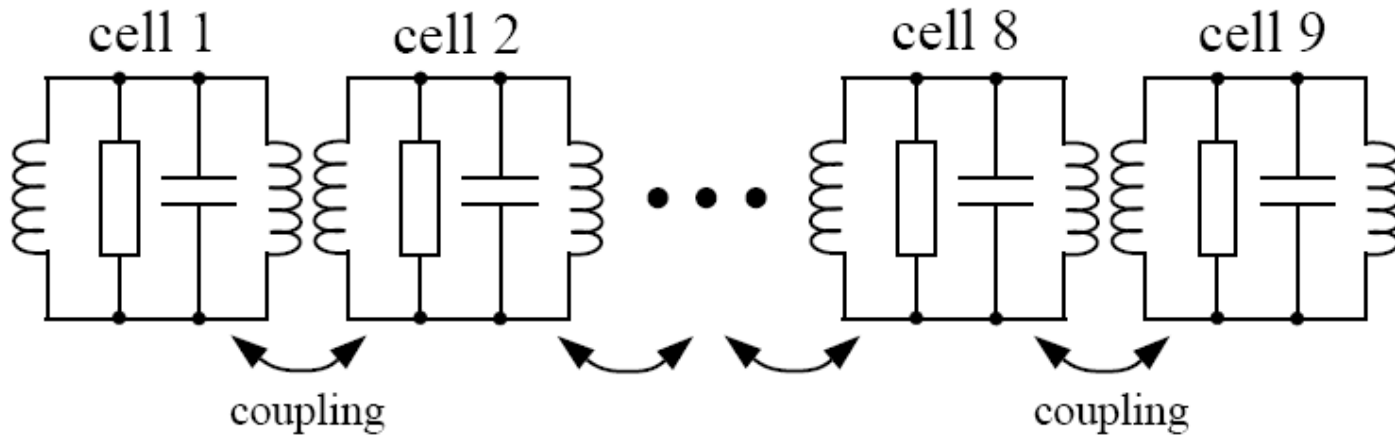

The 9-cell cavity is modeled with nine magnetically coupled resonators.



Pass Band Modes of the 9-Cell Cavity

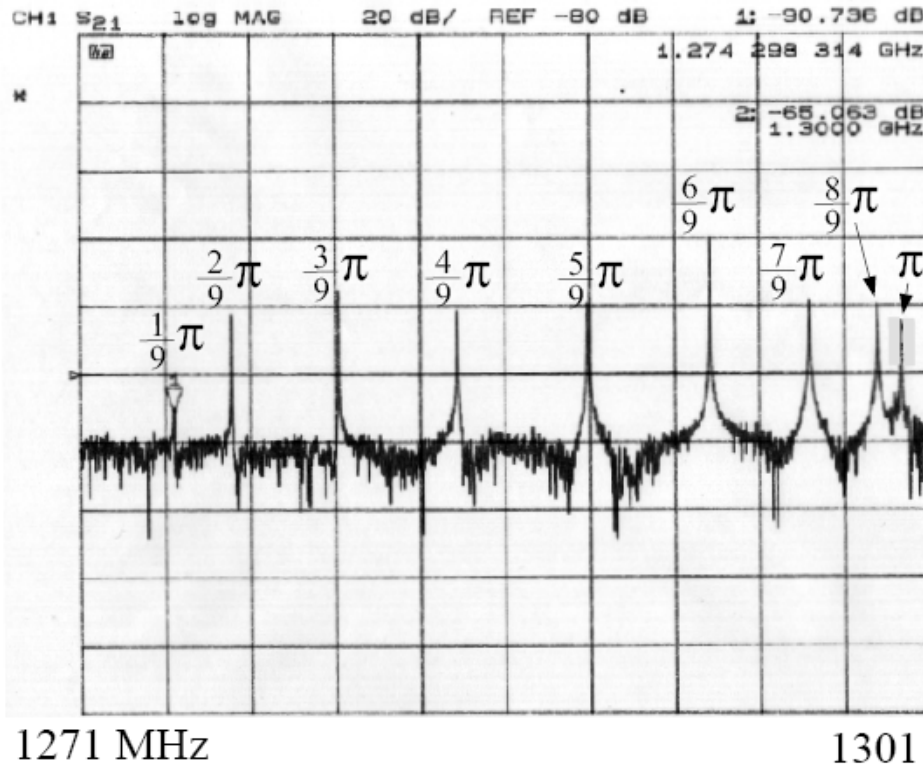

$$f_{\pi} = 1300.091 \text{ MHz}$$

$$f_{8/9\pi} = 1299.260 \text{ MHz}$$

$$f_{7/9\pi} = 1296.861 \text{ MHz}$$

$$f_{6/9\pi} = 1293.345 \text{ MHz}$$

$$f_{5/9\pi} = 1289.022 \text{ MHz}$$

$$f_{4/9\pi} = 1284.409 \text{ MHz}$$

$$f_{3/9\pi} = 1280.206 \text{ MHz}$$

$$f_{2/9\pi} = 1276.435 \text{ MHz}$$

$$f_{1/9\pi} = 1274.387 \text{ MHz}$$

- π mode is selected for accelerating the beam
- $8\pi/9$ is close (800 kHz away) to the operation mode, which may influence the stability of the acc. field

Pass Band Modes of the 9-Cell Cavity

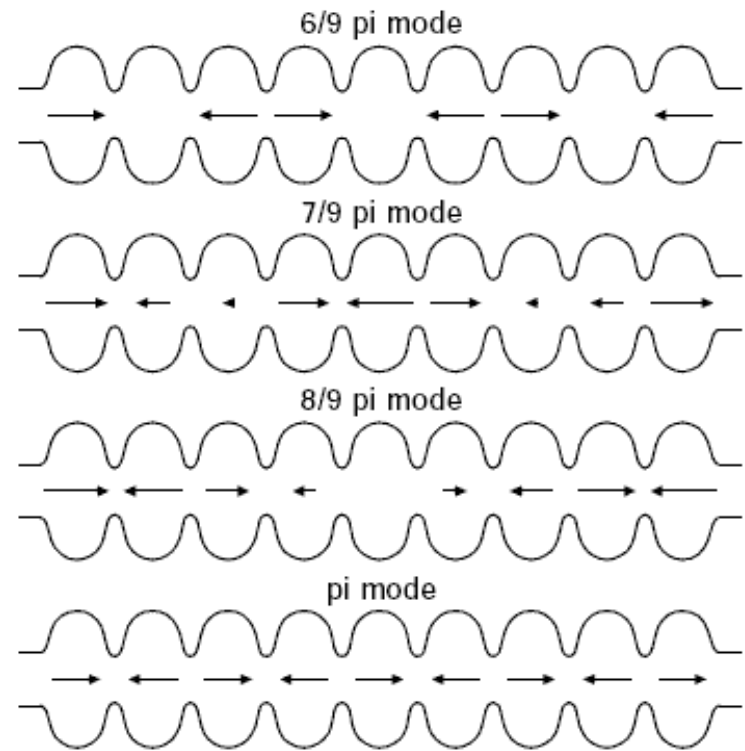
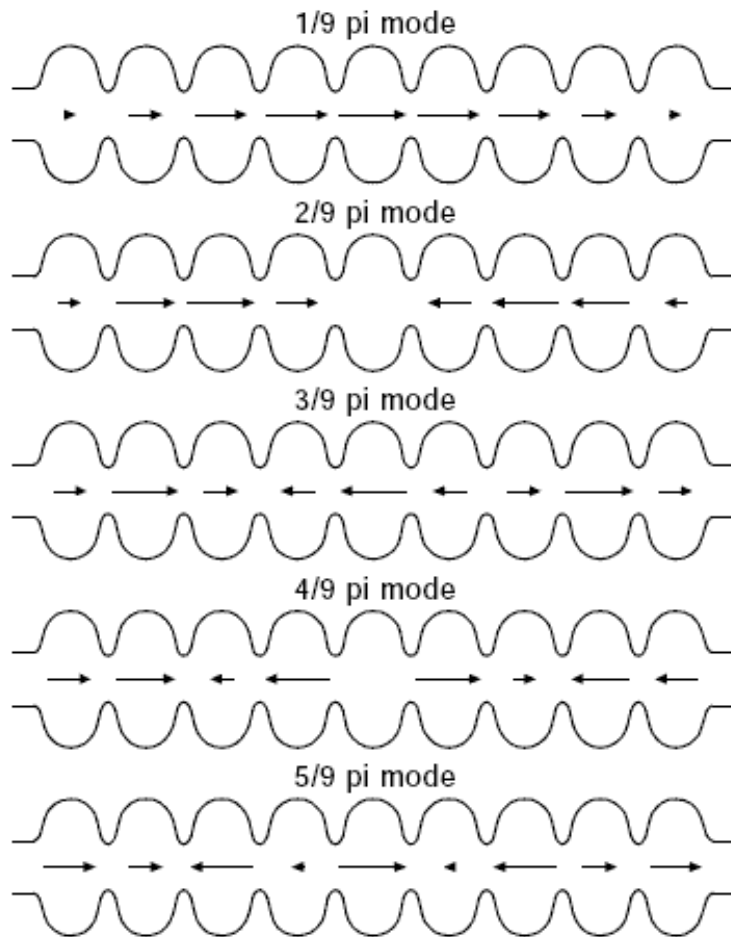

- Arrows show the direction and amplitude of the electric field component along the axis
- π mode is used for beam acceleration

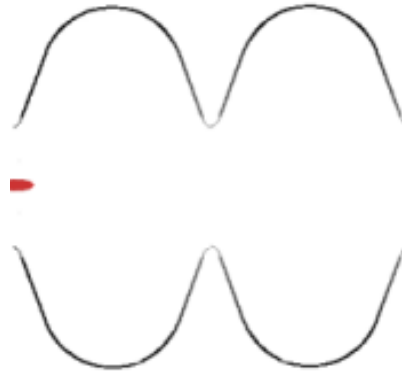
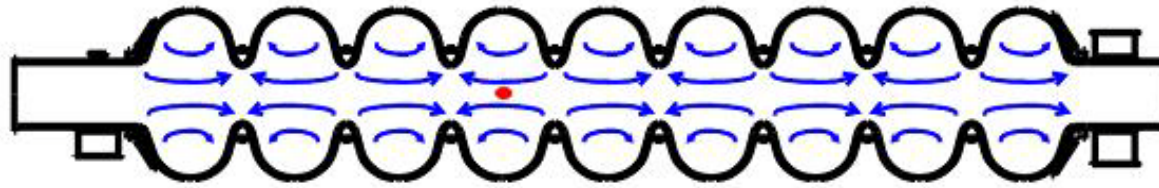

Maximum acceleration voltage

$$V_{acc} = \left| \int_{-L/2}^{L/2} E_z e^{j\omega(z/c)} dz \right|$$

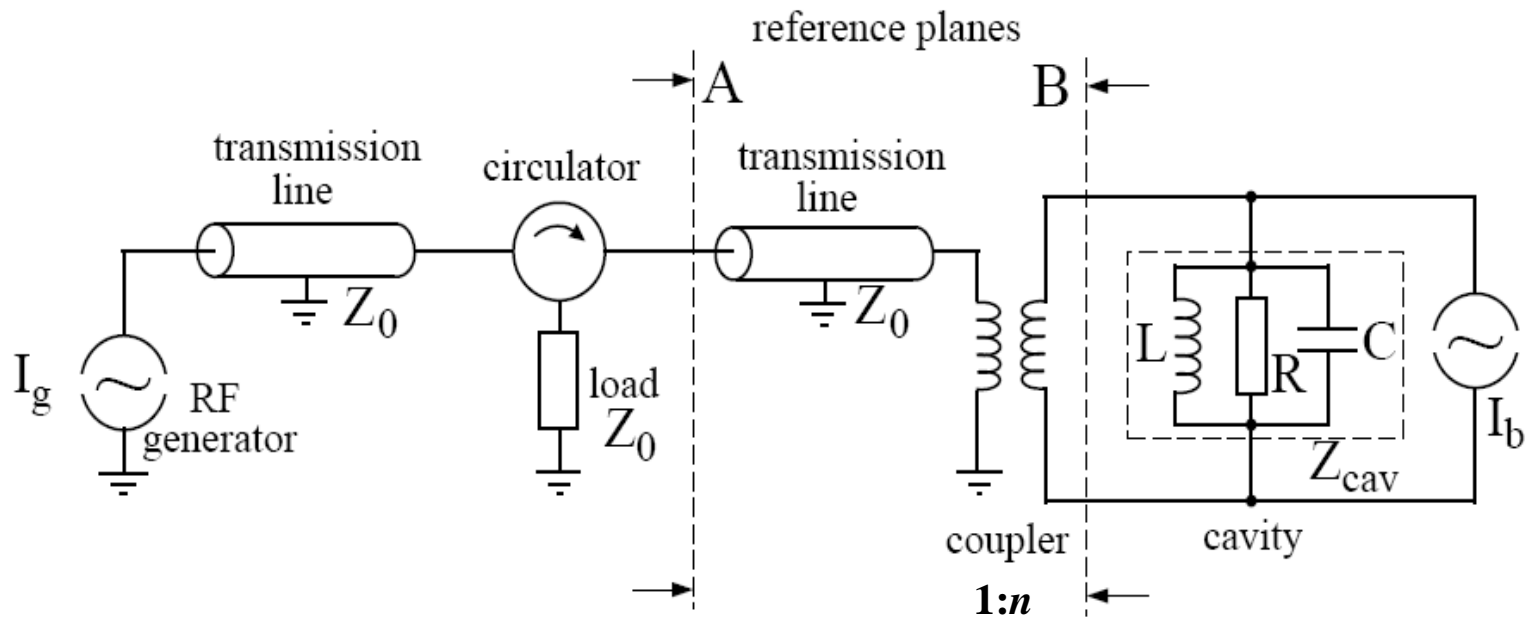

- The whole 9-cell cavity is modeled as an single RLC circuit for the π mode
- Klystron is modeled as a constant-current source
- Power coupler of the cavity is modeled as a lossless transformer

View from Different Reference Plane

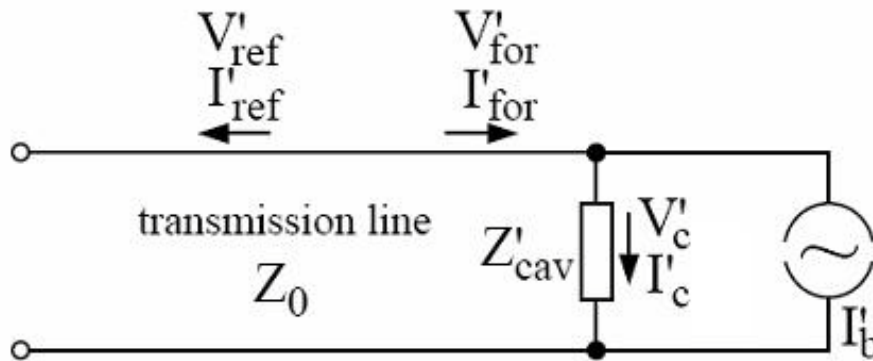
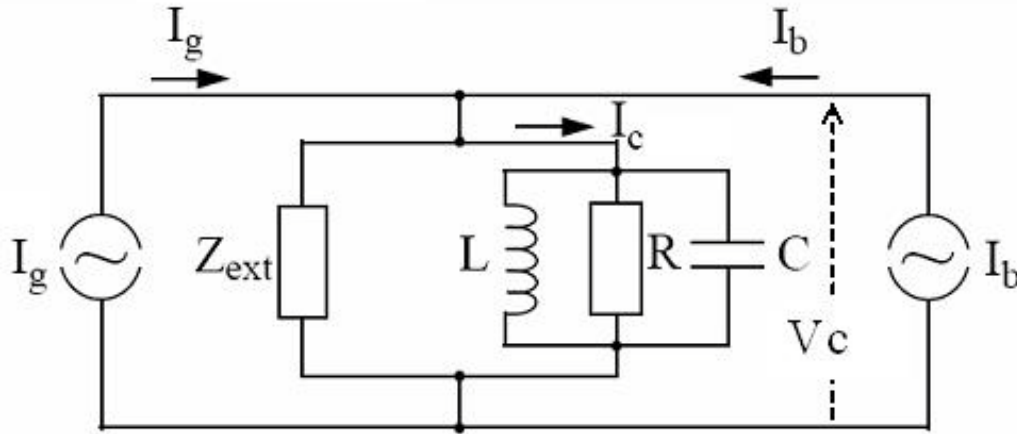

Baseband Equations for Cavity Model

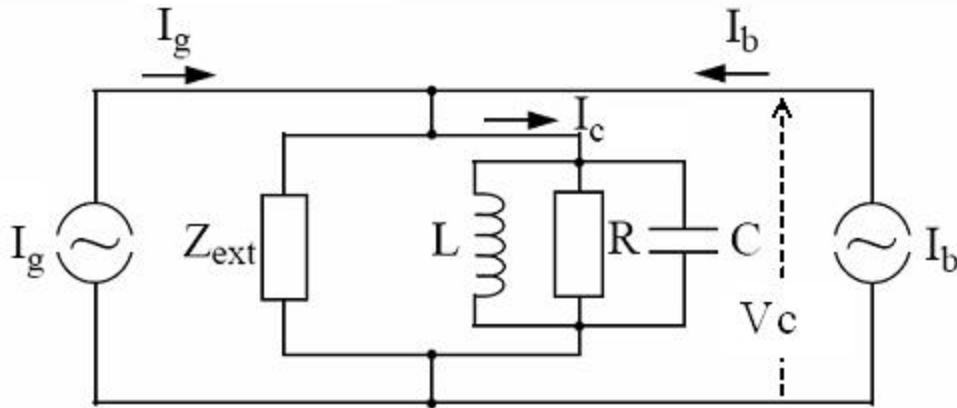

- The equation is described with circuit parameters (R , L , C), which need to be mapped to the measurable cavity characteristics (quality factor, bandwidth, shunt impedance ...)

$$\frac{d^2 V_c}{dt^2} + \frac{1}{R_L C} \frac{dV_c}{dt} + \frac{1}{LC} V_c = \frac{1}{C} \frac{dI}{dt}$$

$$R_L = R // Z_{ext} = \frac{R}{1 + \frac{R}{n^2 Z_0}}$$

$$I = I_g - I_b$$



Relationship between Circuit Parameters and Cavity Characteristics

- Resonance frequency

$$\omega_0 = 2\pi f_0 = 1/\sqrt{LC} \quad (f_0 = 1.3\text{GHz})$$

Numbers in Bracket:
Typical Values for
TESLA Cavity

- Quality factor and input coupling factor

$$Q_0 = \frac{\omega_0 W}{P_{diss,cav}} = \omega_0 RC = \frac{R}{L\omega_0} \quad (\sim 1e10) \quad \left| \quad \beta = \frac{P_{diss,ext}}{P_{diss,cav}} = \frac{Q_0}{Q_{ext}} = \frac{R}{n^2 Z_0} \quad (>3000)$$

$$Q_{ext} = \frac{\omega_0 W}{P_{diss,ext}} = \omega_0 n^2 Z_0 C \quad \left| \quad Q_L = \frac{Q_0}{1 + \beta} \quad (\sim 3e6)$$

- Shunt impedance r and normalized shunt impedance (r/Q)

$$R = \frac{1}{2} r = \frac{1}{2} (r/Q) Q_0$$

$$n = \sqrt{R/\beta Z_0}$$

$$R_L = R // n^2 Z_0 = \frac{R}{1 + \beta} = \frac{1}{2} (r/Q) Q_L$$

($\sim 1554\text{M}\Omega$)

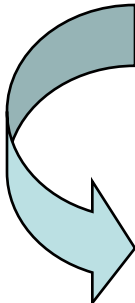

$$\frac{d^2V_c}{dt^2} + \frac{1}{R_L C} \frac{dV_c}{dt} + \frac{1}{LC} V_c = \frac{1}{C} \frac{dI}{dt}$$

$$\frac{d^2V_c}{dt^2} + 2\omega_{1/2} \frac{dV_c}{dt} + \omega_0^2 V_c = 2\omega_{1/2} R_L \frac{dI}{dt}$$

- The half bandwidth of the cavity is defined as

$$\omega_{1/2} = \frac{\omega_0}{2Q_L} = \frac{1}{\tau}, \quad \tau \text{ is the time constant of the cavity}$$

- The cavity voltage V_c and driving current I are always sine signals with phase and amplitude modulation

Differential Equation of the Envelope

Define the phasor for sine signals: $V_c = \vec{V}_c e^{j\omega t}$, $I = \vec{I} e^{j\omega t}$

When studying the cavity behavior with klystron power and beam current, the carrier frequency term is not interested. The base band (envelope) equation will be used.

$$\frac{d^2 V_c}{dt^2} + 2\omega_{1/2} \frac{dV_c}{dt} + \omega_0^2 V_c = 2\omega_{1/2} R_L \frac{dI}{dt}$$

Cavity baseband equation:

$$\frac{d\vec{V}_c}{dt} + (\omega_{1/2} - j\Delta\omega)\vec{V}_c = \omega_{1/2} R_L \vec{I}$$

Detuning is defined as:

$$\Delta\omega = \omega_0 - \omega \ll \omega$$

Assumptions:

$$\omega_{1/2} \ll \omega$$

Valid for high Q cavities

Variations of the Cavity Equation

- Voltage driven cavity equation

$$\frac{d\vec{V}_c}{dt} + (\omega_{1/2} - j\Delta\omega)\vec{V}_c = 2\omega_{1/2} \frac{\beta}{\beta + 1} \vec{V}_{for}$$

Valid for both normal-conducting and superconducting cavity

- For superconducting cavity

$$\beta \gg 1$$

So the cavity equation can be simplified as

$$\frac{d\vec{V}_c}{dt} + (\omega_{1/2} - j\Delta\omega)\vec{V}_c = 2\omega_{1/2} \vec{V}_{for}$$

Valid for cavities with large coupling factor, such as the superconducting cavity

State Differential Equation of the Cavity

- Separate the real and imaginary parts of the complex cavity equation, we will get the state differential equation

$$\frac{d\vec{V}_c}{dt} + (\omega_{1/2} - j\Delta\omega)\vec{V}_c = \omega_{1/2}R_L\vec{I}$$



$$\vec{V}_c = V_{cr} + jV_{ci}, \quad \vec{I} = I_r + jI_i$$

$$\frac{d}{dt} \begin{bmatrix} V_{cr} \\ V_{ci} \end{bmatrix} = \begin{bmatrix} -\omega_{1/2} & -\Delta\omega \\ \Delta\omega & -\omega_{1/2} \end{bmatrix} \begin{bmatrix} V_{cr} \\ V_{ci} \end{bmatrix} + \omega_{1/2}R_L \begin{bmatrix} I_r \\ I_i \end{bmatrix}$$

- State equation is suitable for digital simulation and implementation, and can fit to the framework of modern signal processing and control theory
- Complex equation is suitable for analysis



Steady State Behavior of the Cavity – Resonance Curves

- Steady State: no transient, the item with time derivative equals to zero

$$\vec{V}_c = \frac{\omega_{1/2} R_L \vec{I}}{\omega_{1/2} - j\Delta\omega} \Rightarrow \begin{cases} |\vec{V}_c| = R_L |\vec{I}| \cos \psi, & \angle \vec{V}_c - \angle \vec{I} = \psi \\ \text{where } \psi = \tan^{-1}(\Delta\omega/\omega_{1/2}) \text{ is the detuning angle} \end{cases}$$

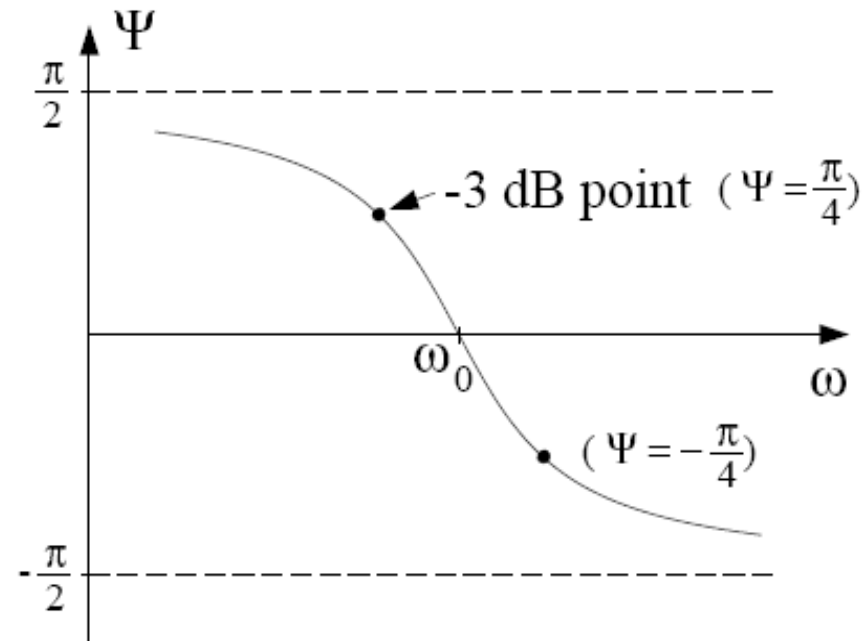
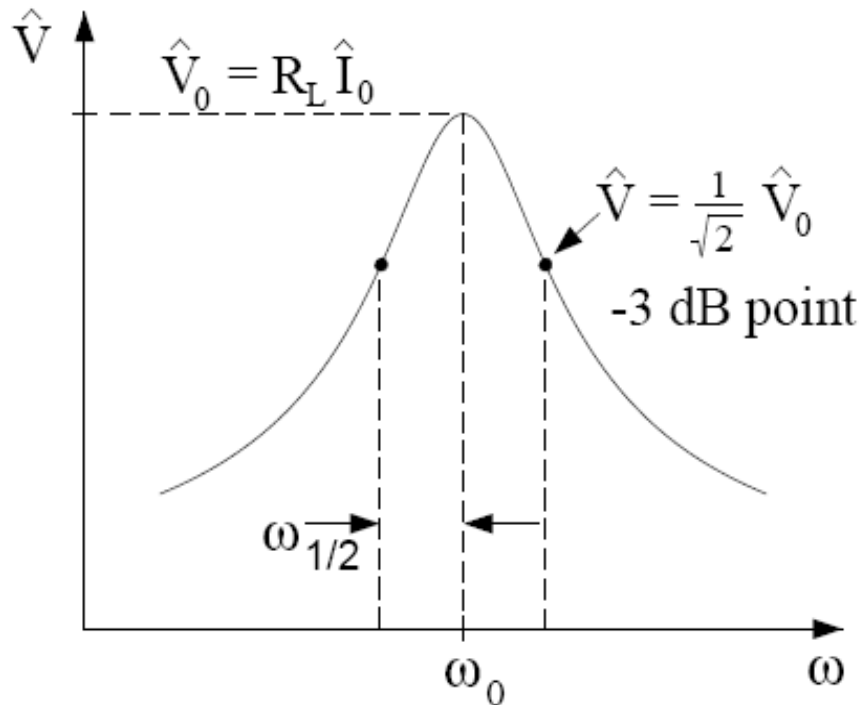

$$|\vec{V}_c| = R_L |\vec{I}| \cos \psi, \quad \angle \vec{V}_c - \angle \vec{I} = \psi$$

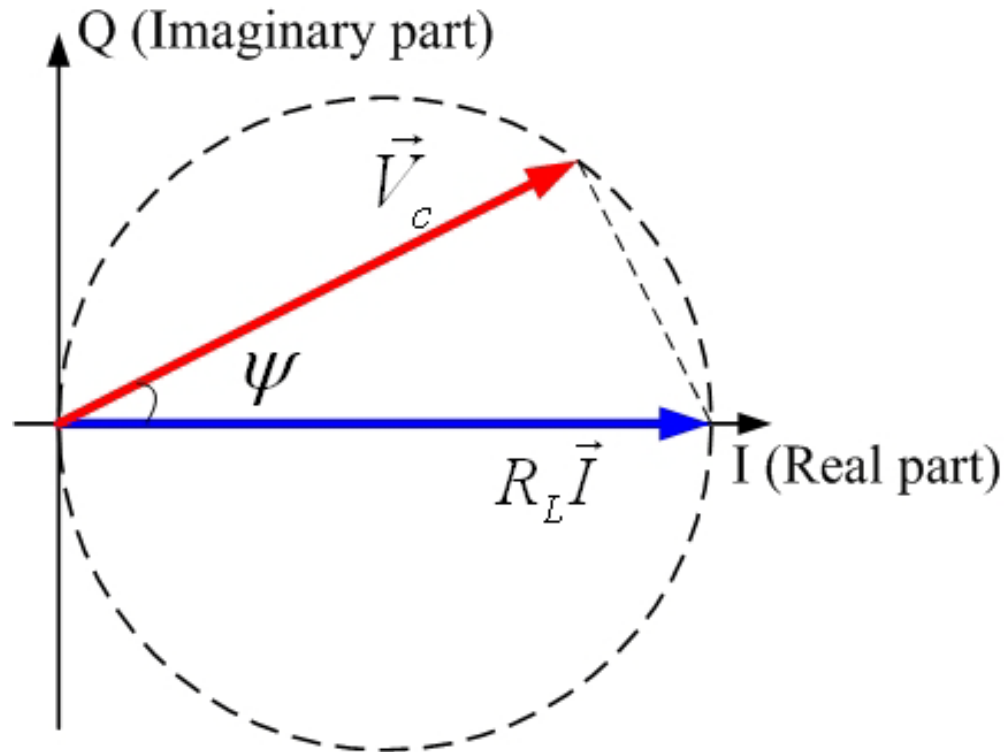

Transient Behavior of the Cavity

- Transient behavior: step response of the cavity

$$\vec{V}_c(t) = \frac{\omega_{1/2} R_L \vec{I}}{\omega_{1/2} - j\Delta\omega} \left(1 - e^{-(\omega_{1/2} - j\Delta\omega)t} \right)$$

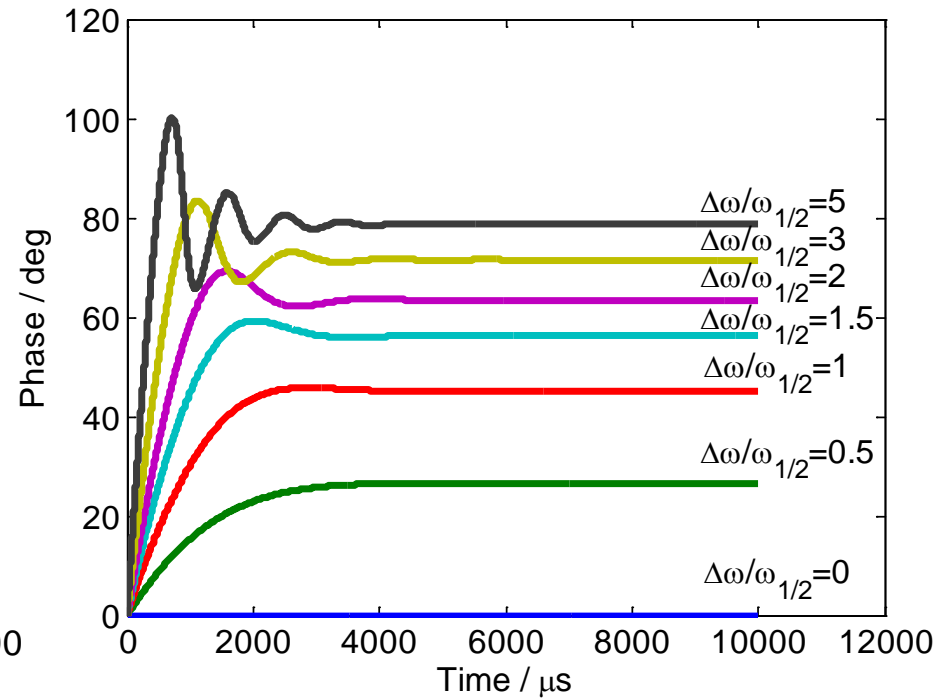
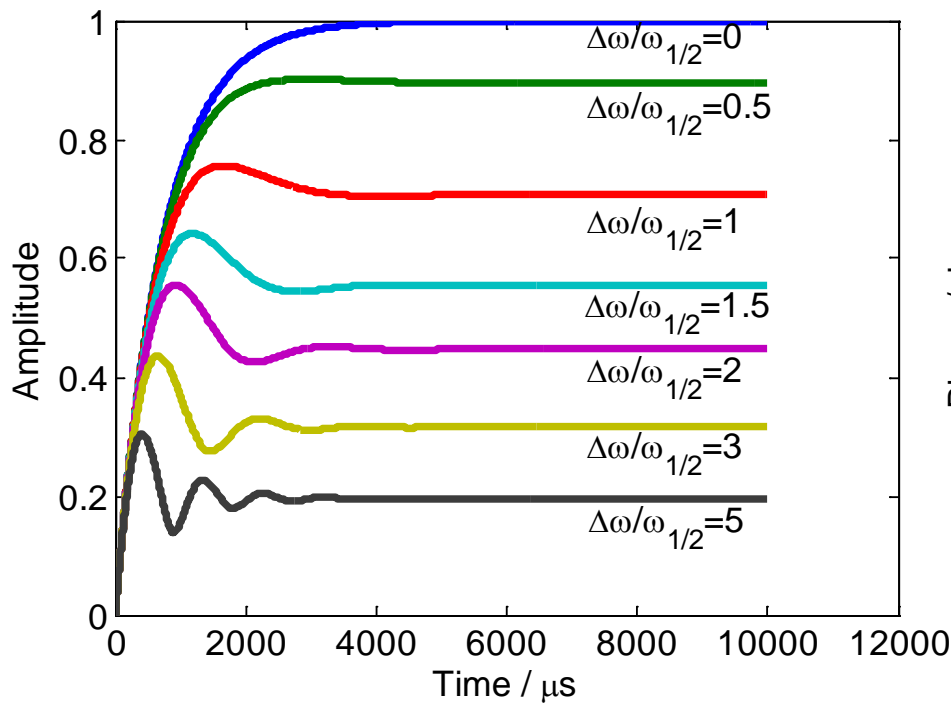

Transient Behavior of the Cavity

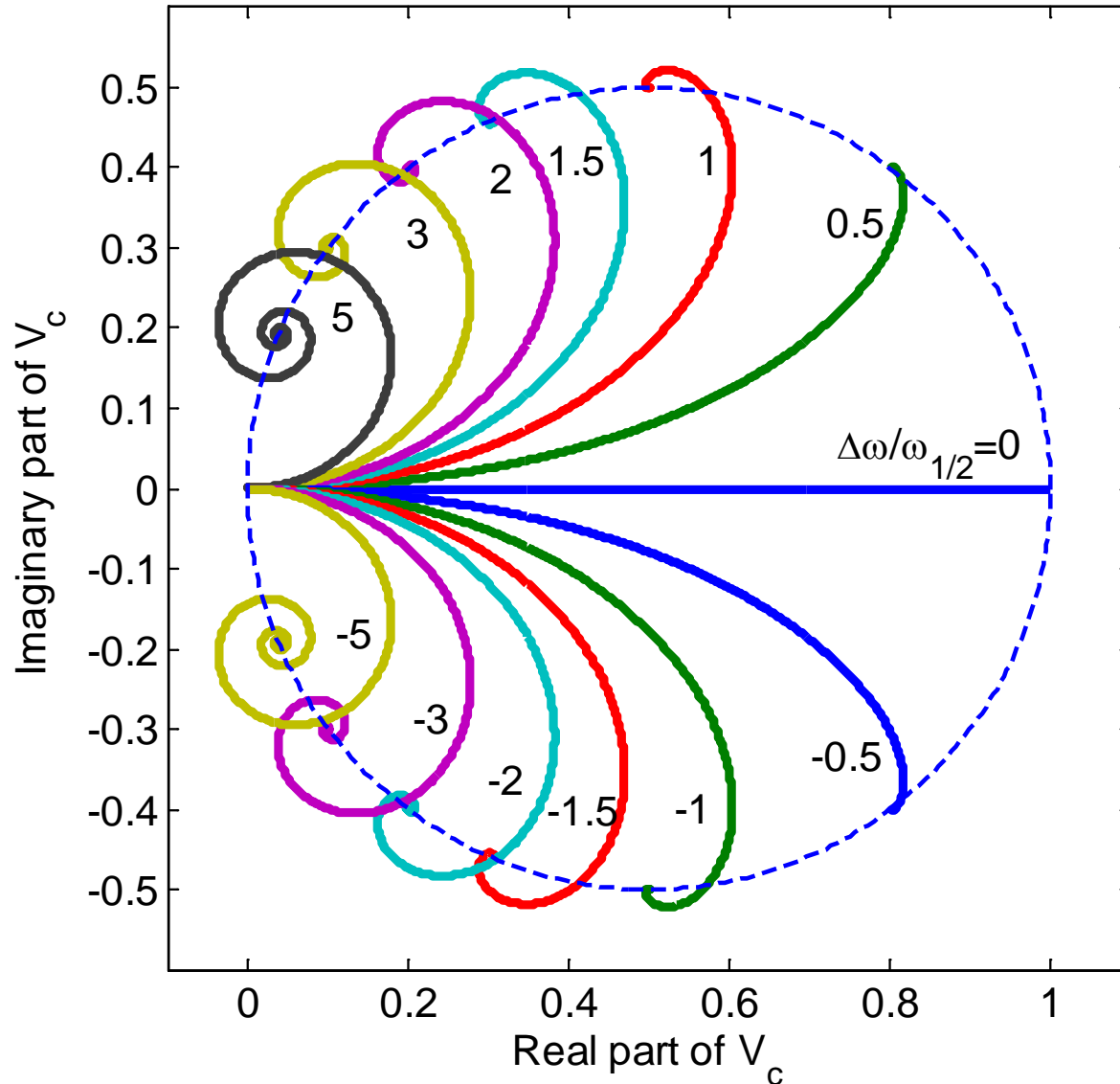

Driving Term in Cavity Equations

Typical Parameters in Pulsed System

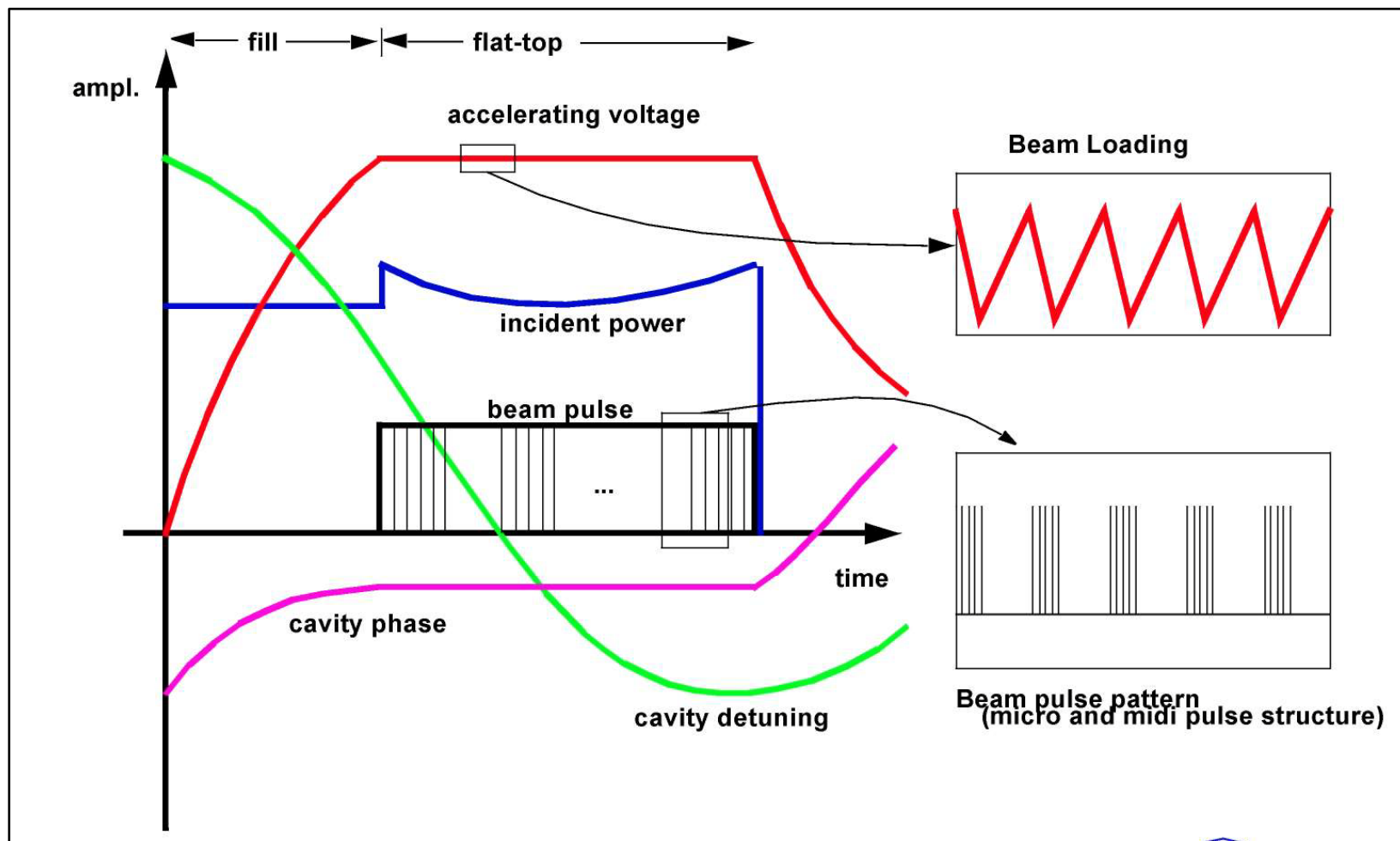

Relationship of Driving Term in Cavity Equation to Klystron Power and Beam Current

Remind the cavity baseband equation:

$$\frac{d\vec{V}_c}{dt} + (\omega_{1/2} - j\Delta\omega)\vec{V}_c = \omega_{1/2}R_L\vec{I}$$

The driving term is the superposition of the generator current and beam current:

$$\vec{I} = \vec{I}_g + \vec{I}_b$$

$$|\vec{I}_g| = f(P_{for}, Z_{cav}, Z_0, \beta)$$

$$|\vec{I}_b| = g(Q_{bunch}, f_{bunch})$$

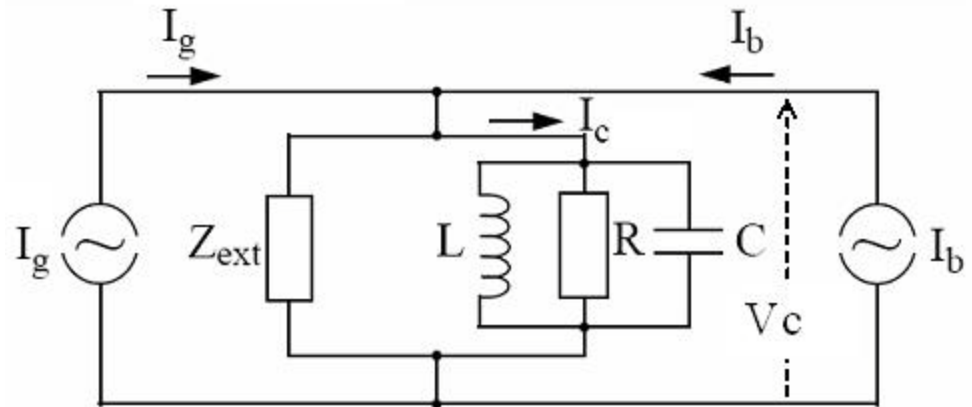

- The generator current is a function of the klystron power, cavity and transmission line impedance, and input coupling factor
- The beam current is a function of bunch charge and bunch repetition rate



Relationship of the Generator Current and Klystron Power

Cavity equation driven by klystron power and beam:

$$\frac{d\vec{V}_c}{dt} + (\omega_{1/2} - j\Delta\omega)\vec{V}_c = \omega_{1/2}R_L(\vec{I}_g + \vec{I}_b)$$

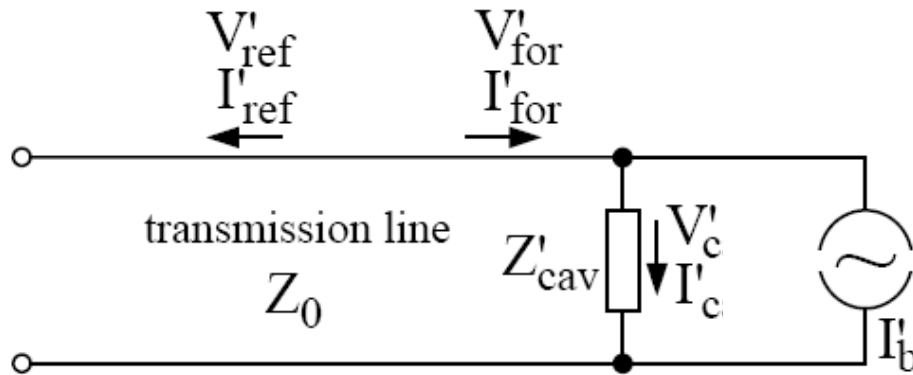

$$\Gamma = \frac{Z'_{cav} - Z_0}{Z'_{cav} + Z_0}$$

$$\vec{V}'_{ref} = \Gamma \vec{V}'_{for} \quad V'_{for} = Z_0 I'_{for}$$

$$\vec{V}'_c = \vec{V}'_{for} + \vec{V}'_{ref} = \frac{2Z'_{cav}Z_0}{Z'_{cav} + Z_0} \vec{I}'_{for}$$

Translate to the cavity side of the transformer, we will get $\vec{V}_c = R_L \cdot 2\vec{I}'_{for}$

During steady state, when there is no beam and detuning (Ohm's law), so $\vec{V}_c = R_L \cdot \vec{I}_g$

$$|\vec{I}_g| = 2|\vec{I}'_{for}| = \frac{2|\vec{I}'_{for}|}{n} = 2\sqrt{\frac{2\beta P_{for}}{R}} \approx 2\sqrt{\frac{2P_{for}}{R_L}}, \quad |\vec{I}'_{for}| = \sqrt{\frac{2P_{for}}{Z_0}}$$

Cavity equation driven by klystron power and beam:

$$\frac{d\vec{V}_c}{dt} + (\omega_{1/2} - j\Delta\omega)\vec{V}_c = \omega_{1/2}R_L(\vec{I}_g + \vec{I}_b)$$

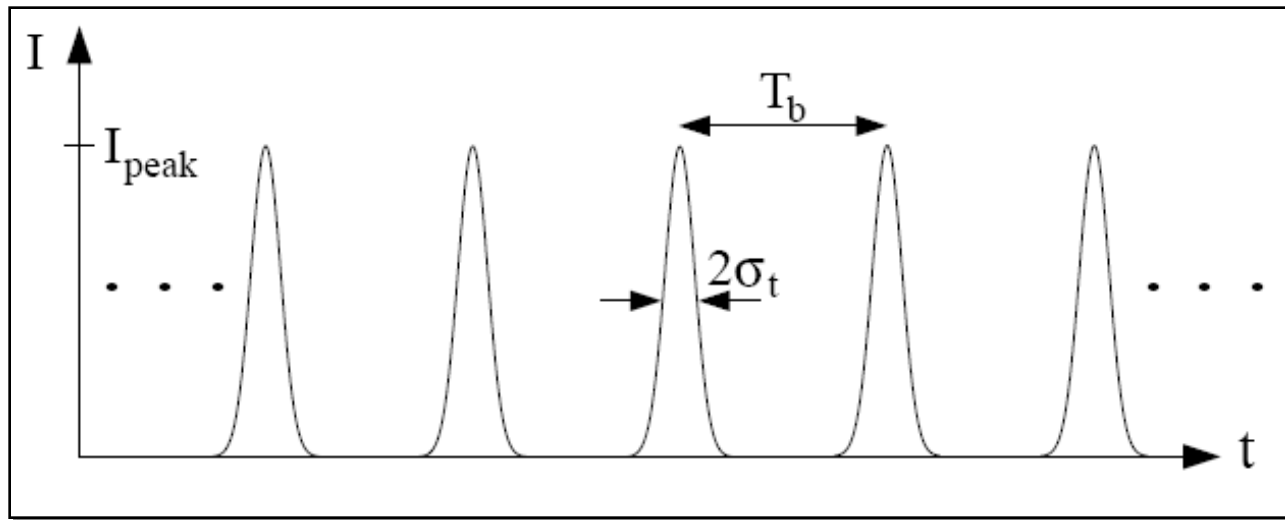

A single bunch is described by a Gaussian curve:

$$I(t) = \frac{Q_0}{\sqrt{2\pi}\sigma_t} \cdot e^{-\frac{t^2}{2\sigma_t^2}} = I_{peak} \cdot e^{-\frac{t^2}{2\sigma_t^2}}$$



Relationship of the Beam Current and Average DC Beam Current (cont'd)

Fourier decomposition of bunch train:

$$I(t) = a_0/2 + \sum_{n=1}^{\infty} [a_n \cos(n\omega_b t) + b_n \sin(n\omega_b t)]$$

$$\begin{cases} \omega_b = 2\pi/T_b \\ a_n = 2I_{peak} \sqrt{2\pi} \cdot \sigma_t / T_b \cdot e^{-n^2 \omega_b^2 \sigma_t^2 / 2} & n = 0, 1, 2, \dots \\ b_n = 0 & n = 1, 2, \dots \end{cases}$$

Average DC beam current:

$$I_{b0} = I_{peak} \sqrt{2\pi} \sigma_t / T_b = Q_0 / T_b$$

Beam current in cavity equation:

$$a_n = 2I_{b0} \cdot e^{-n^2 \omega_b^2 \sigma_t^2 / 2}$$

$$|\vec{I}_b| = a_n(1300\text{MHz}) \approx 2I_{b0}$$

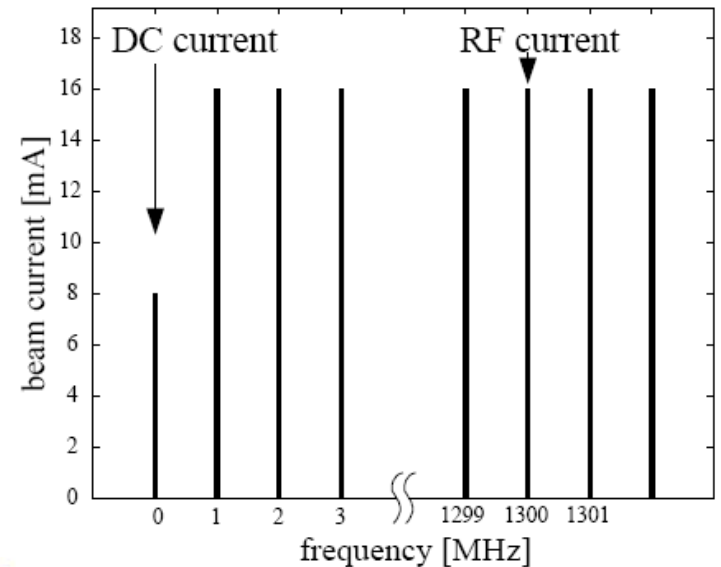
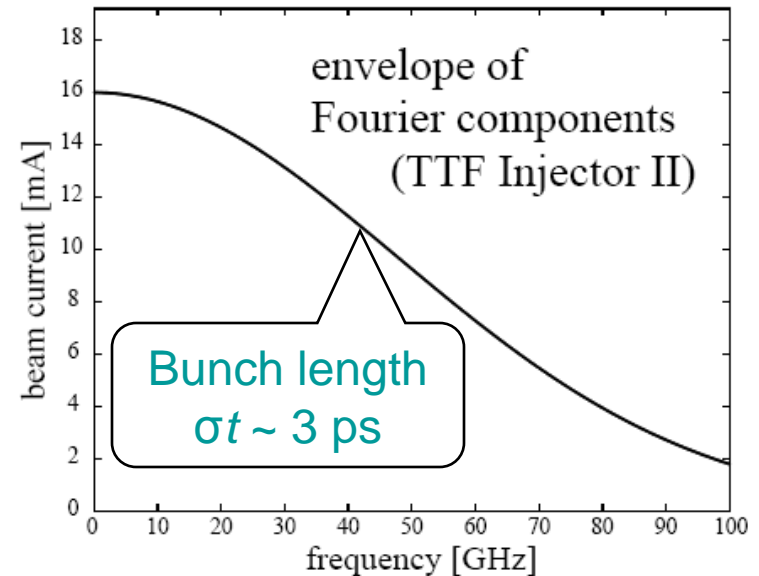

Beam Phase Respect to RF

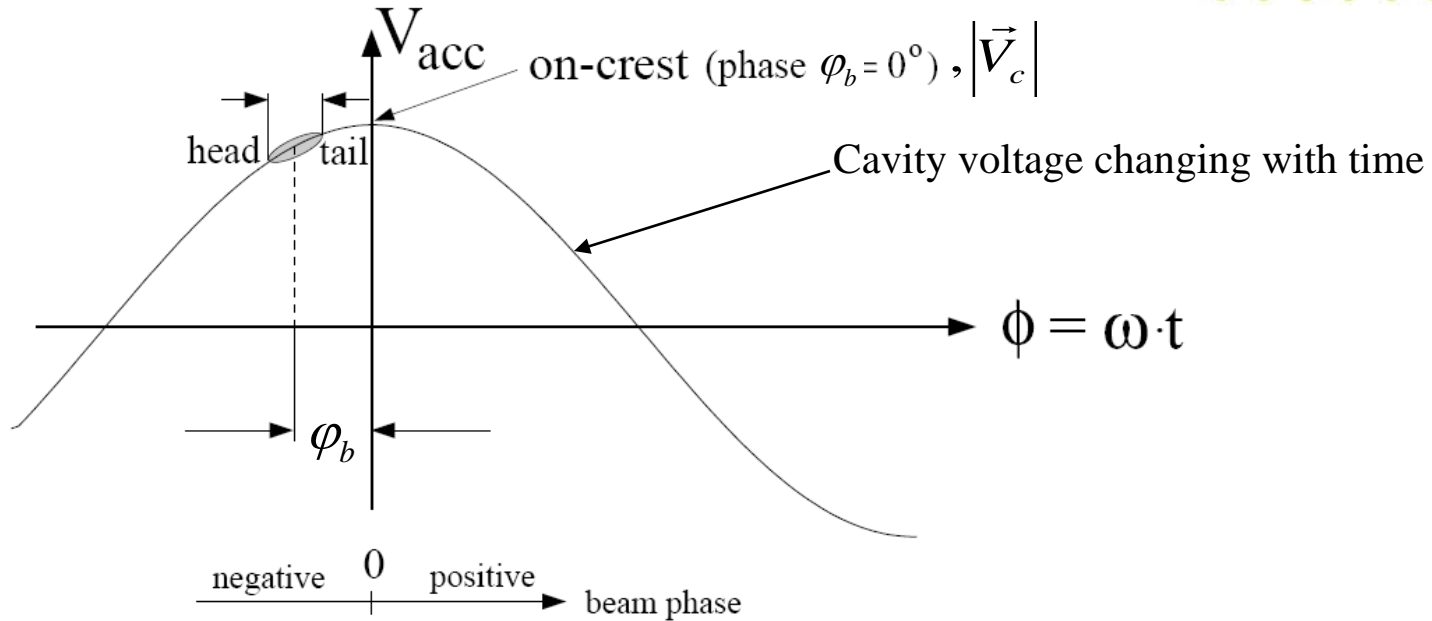

With items in cavity equation:
$$\frac{d\vec{V}_c}{dt} + (\omega_{1/2} - j\Delta\omega)\vec{V}_c = \omega_{1/2}R_L(\vec{I}_g + \vec{I}_b)$$

Beam Phase Definition:
$$\varphi_b = 180^\circ - (\angle\vec{I}_b - \angle\vec{V}_c) \quad \text{mod } 360^\circ$$

Energy gain of single particle:
$$\Delta E = |\vec{V}_c| \cos \varphi_b$$

Beam Loading in the Cavity

RF generator induced voltage

Beam induced voltage

On-crest acceleration

- Beam loading is significant in superconducting cavities
- Beam induced voltage cancels the exponential increase of the generator induced voltage, resulting in a flattop

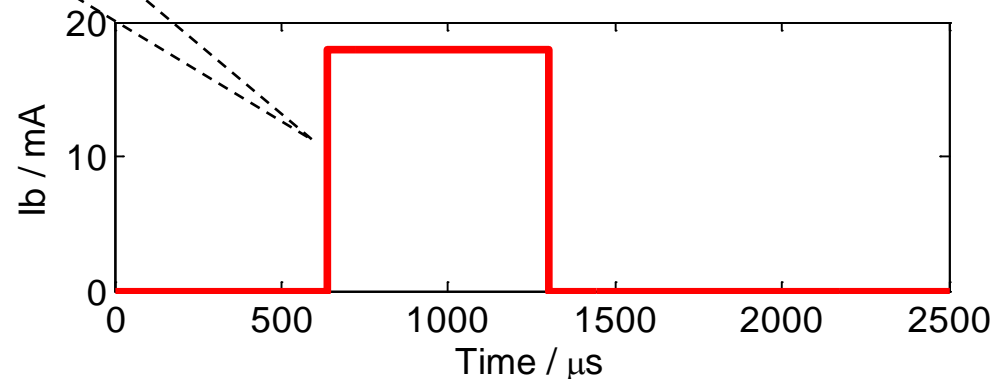
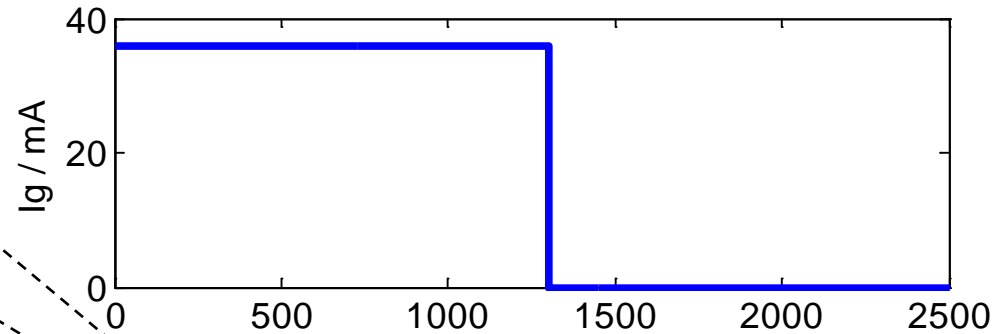
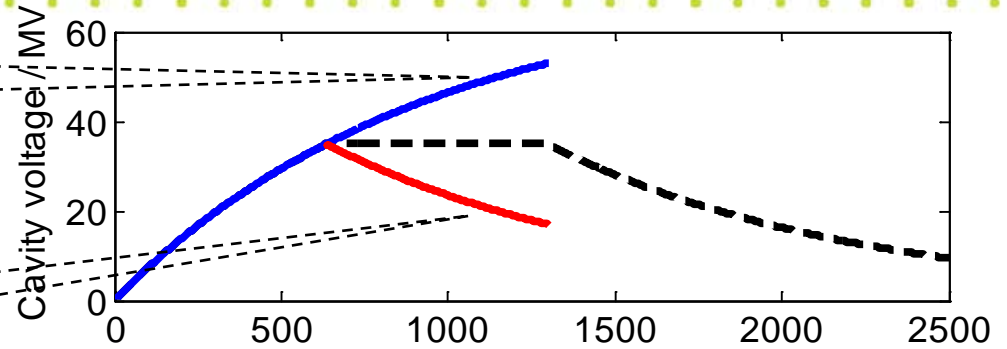

Beam Injection Time for Flattop

If the beam is accelerated **on-crest** and there is **no detuning**, the beam injection time for flattop is

$$t_{inj} = \frac{1}{\omega_{1/2}} \cdot \ln \left(\frac{|\vec{I}_g|}{|\vec{I}_b|} \right) = \tau \cdot \ln \left(\frac{|\vec{I}_g|}{|\vec{I}_b|} \right)$$

For TESLA cavity,

$$t_{inj} = 734 \mu\text{s} \cdot \ln(16\text{mA}/8\text{mA}) = 510 \mu\text{s}$$

RF Power Dissipation and Reflection of a Cavity



RF Power Profile for Cavity Operation

- **Filling Stage:** cavity voltage increases from zero with the cavity driving power
- **Flattop Stage:** cavity voltage keeps constant for beam acceleration, which is a nearly steady-state condition

No Beam

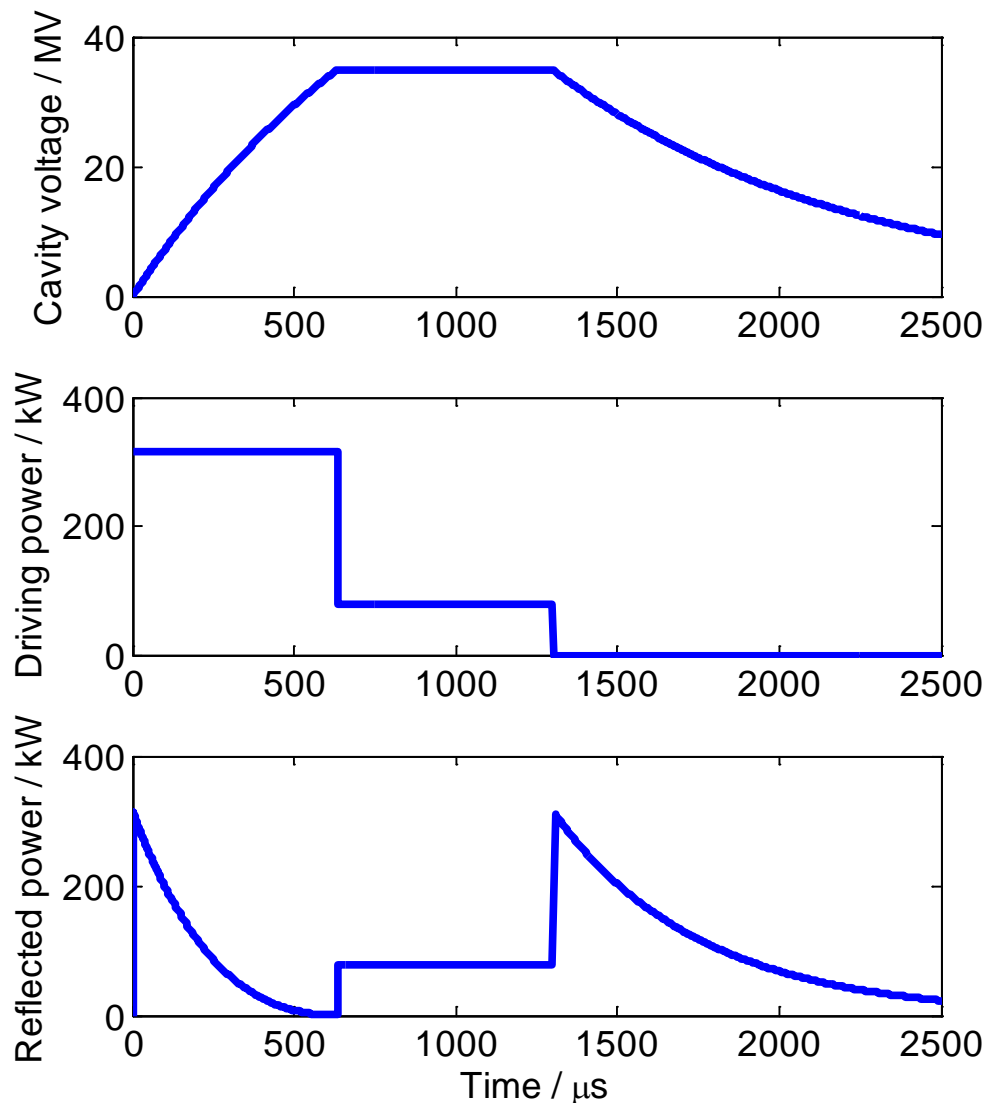

RF Power Dissipation and Reflection at Filling Stage



RF Power Dissipation at Filling Stage

- Filling of cavity: fill the cavity to a desired voltage V_0 from 0 within a period of T_{fill}
- Factors influence the required filling power
 - Desired cavity flattop voltage (V_0)
 - Filling time (T_{fill})
 - Loaded Q of cavity (Q_L)
 - Detuning of cavity ($\Delta\omega$)
- From the cavity transient behavior, the RF power required for filling stage is

$$P_{fill} = \frac{V_0^2 (\omega_0^2 + 4Q_L^2 \Delta\omega^2)}{4 \left(\frac{r}{Q} \right) Q_L \omega_0^2 \cdot \left[1 + e^{-\frac{\omega_0 T_{fill}}{Q_L}} - 2e^{-\frac{\omega_0 T_{fill}}{2Q_L}} \cos(\Delta\omega T_{fill}) \right]}$$



Filling Power for Different Loaded Q and Filling Time

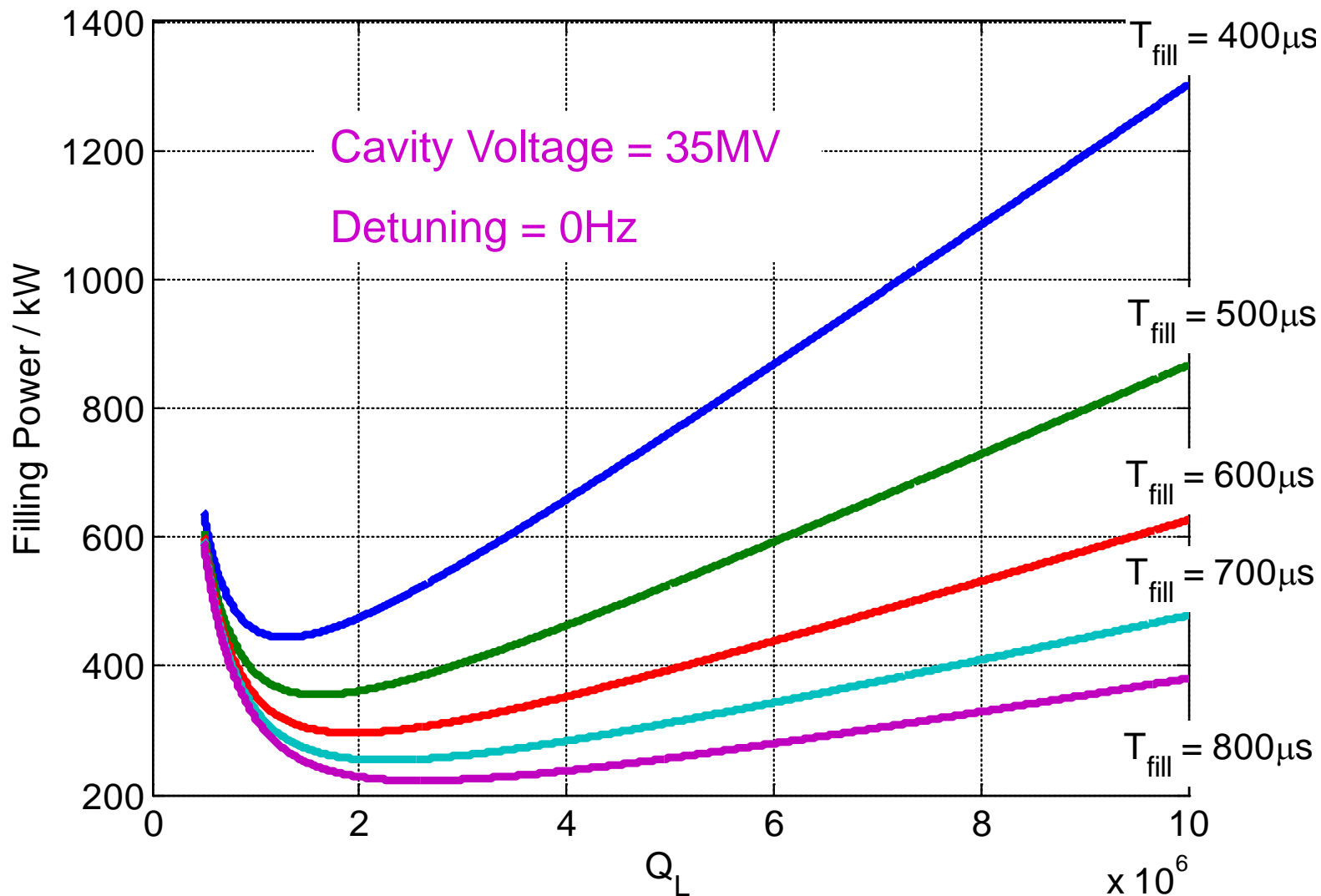



Filling Power for Different Loaded Q and Detuning

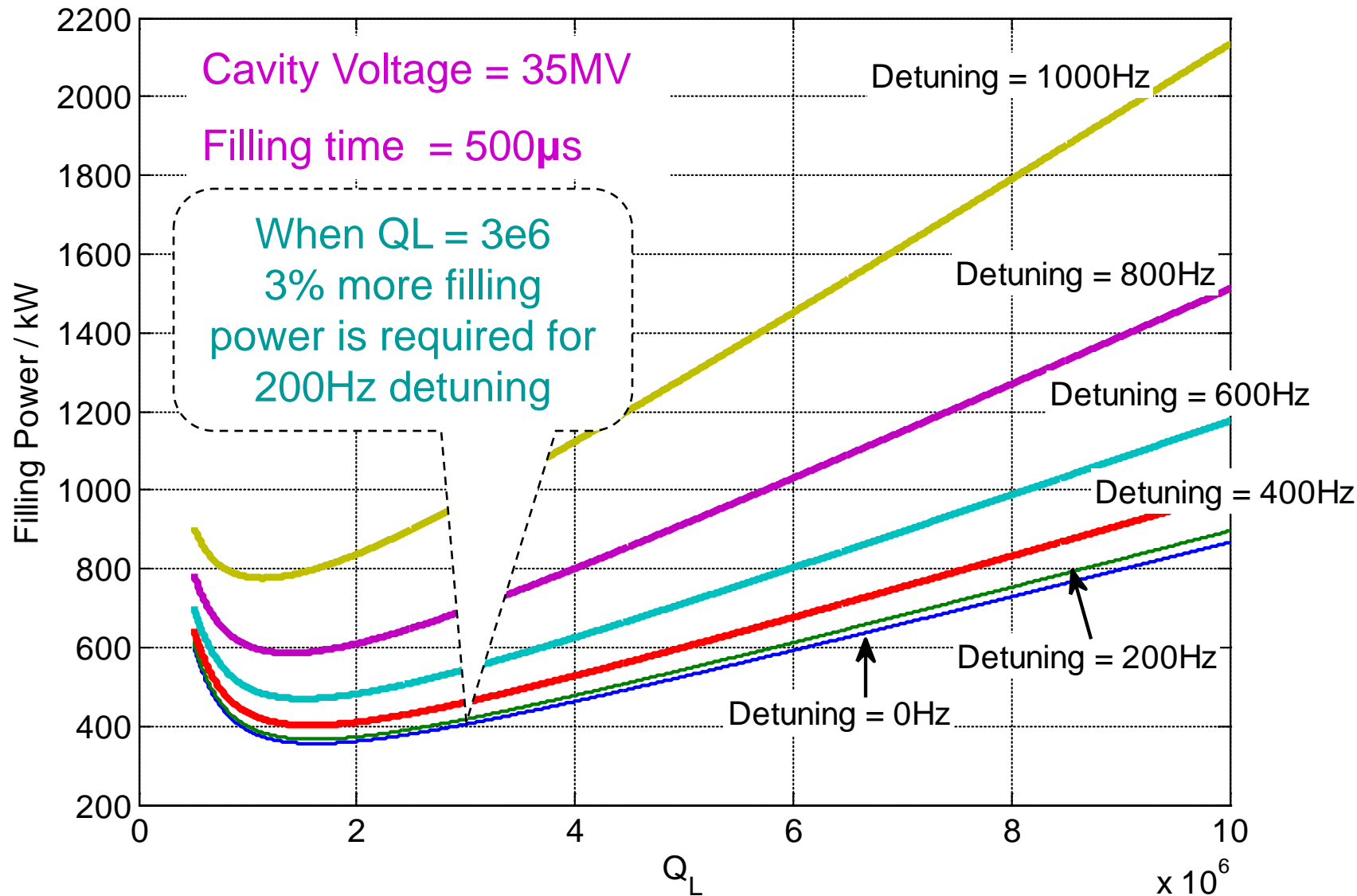

- Reflection power can be calculated via the relationship of

$$\vec{V}_c = \vec{V}_{for} + \vec{V}_{ref}$$

- At the beginning of the RF pulse, the cavity voltage is zero, so the reflection power equals to the forward power, and when the cavity voltage increases, the reflection power decrease

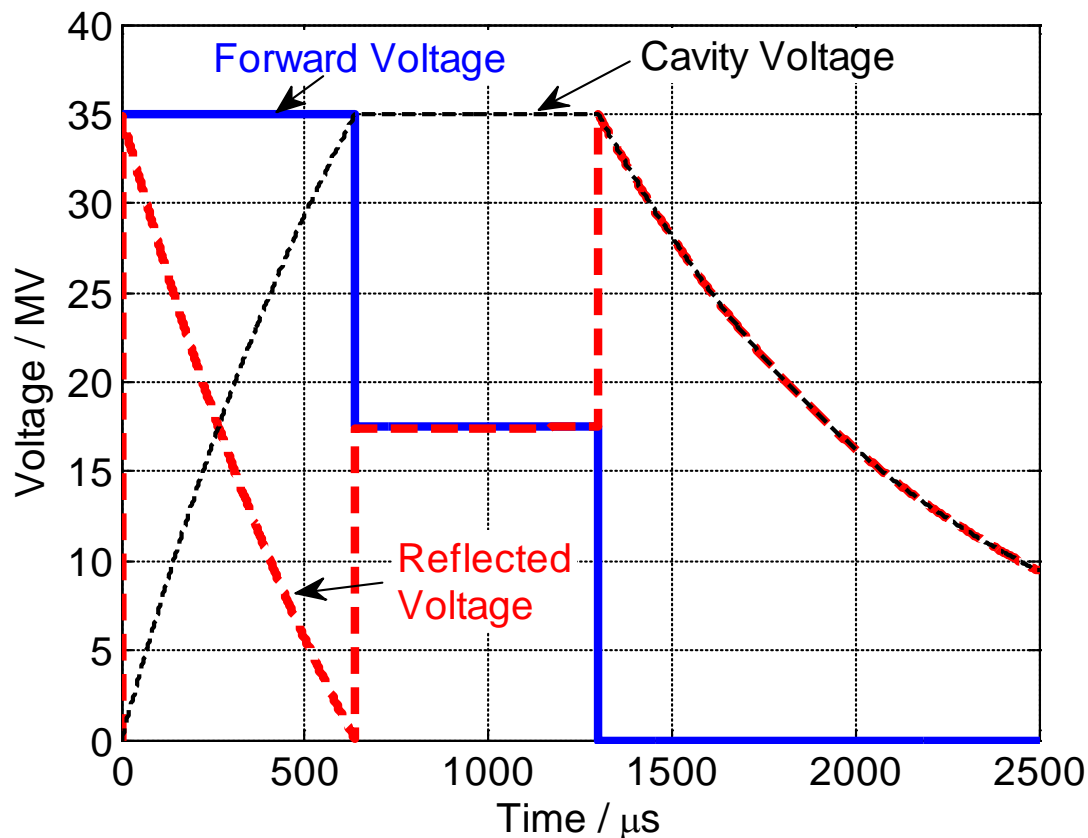

RF Power Dissipation and Reflection at Flattop Stage



RF Power Dissipation at Flattop Stage

- Flattop of cavity: keep the cavity voltage to a desired value V_0 in presence of beam current I_b
- Factors influence the required flattop power
 - Desired cavity flattop voltage (V_0)
 - Beam current and beam phase (I_b)
 - Loaded Q of cavity (Q_L)
 - Detuning of cavity ($\Delta\omega$)
- During flattop, the cavity is approximately in steady state, so steady state equations can be used

Recall: cavity resonance circle for steady state behavior

$$|\vec{V}_c| = R_L |\vec{I}| \cos \psi$$

$$\angle \vec{V}_c - \angle \vec{I} = \psi$$

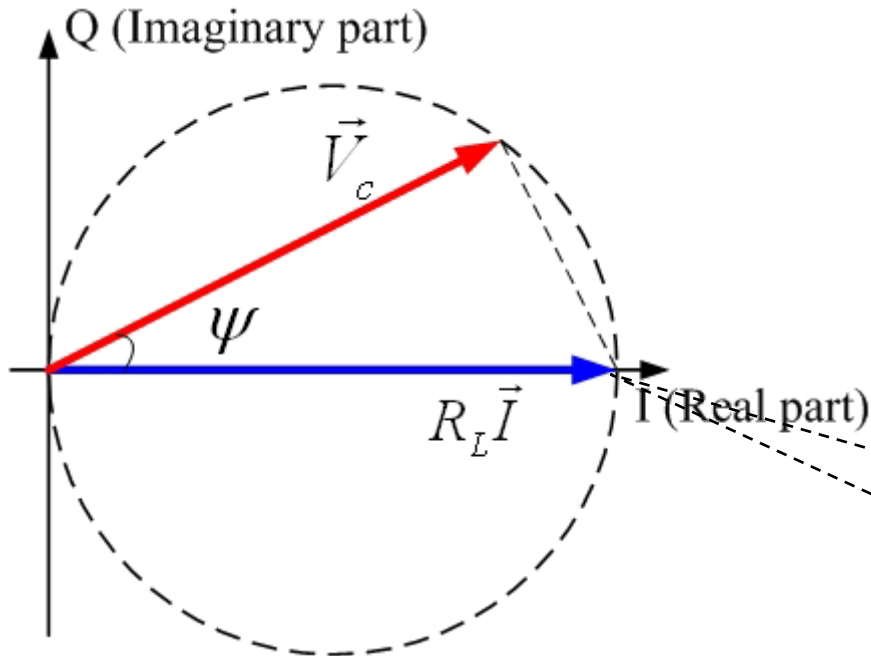

If there is no beam, the cavity is driven by the forward voltage concern to klystron power

$$R_L \vec{I} = 2R_L \vec{I}_{for} = 2\vec{V}_{for}$$

$$\vec{V}_c = 2\vec{V}_{for} \cos \psi \cdot e^{j\psi}$$

$$\psi = \tan^{-1}(\Delta\omega/\omega_{1/2})$$

(detuning angle)

Cavity voltage on resonance:

$$2\vec{V}_{for}$$

Vector Diagram for Cavity Driving

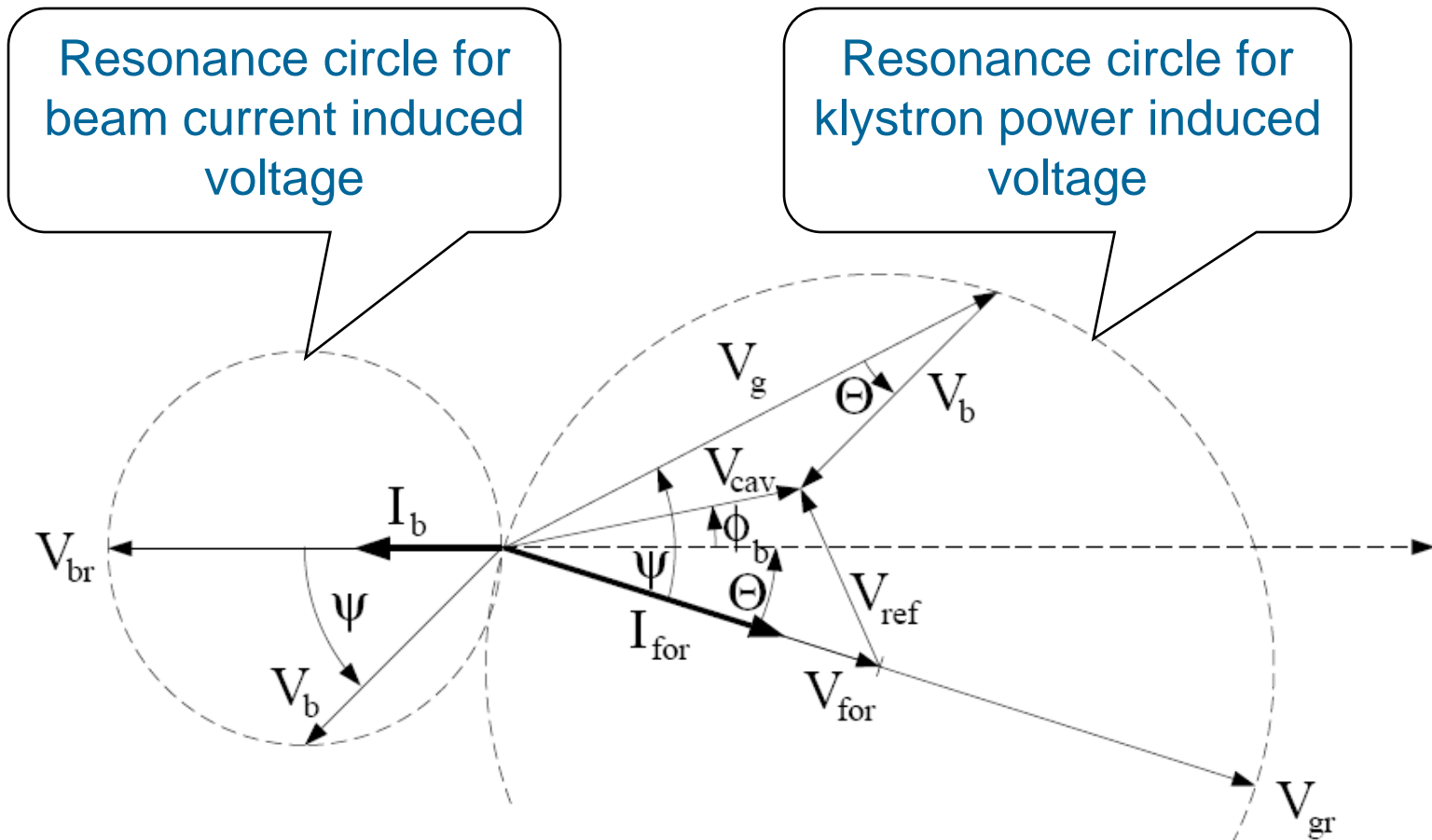

Vector diagram of generator- and beam-induced voltages in a detuned cavity. The angle ϕ_b denotes the beam phase and ψ the tuning angle.

Effect of Detuning

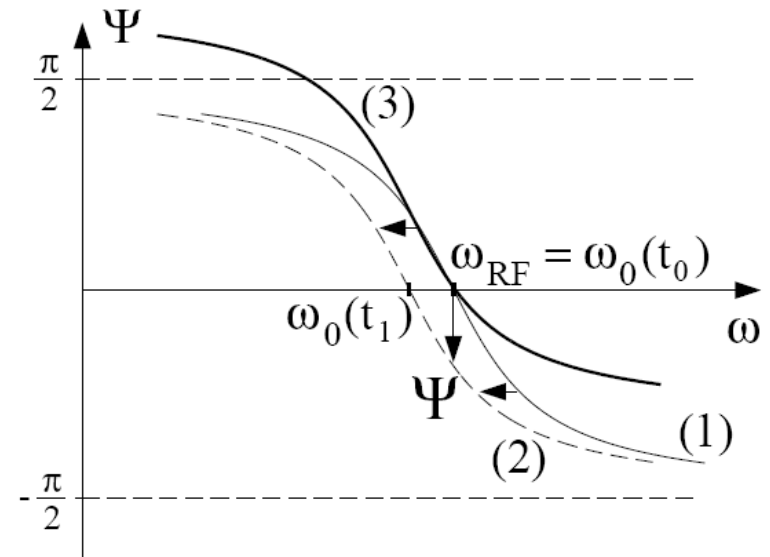
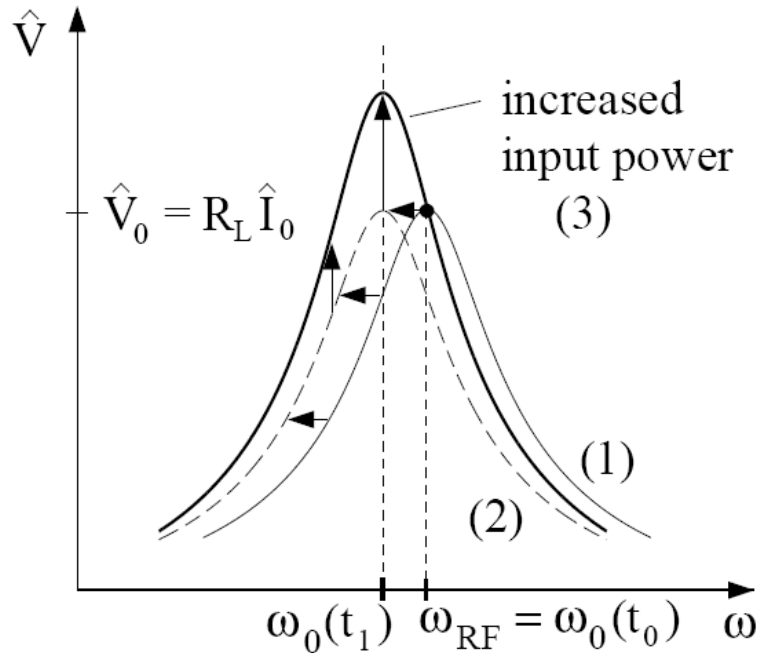

- Detuning will decrease the cavity voltage and shift the cavity phase
- More input power will be needed to maintain the cavity voltage
- Input phase should be changed to compensate the phase shift



Klystron Power in Presence of Beam and Detuning

$$P_g = \frac{V_{cav}^2}{\left(\frac{r}{Q}\right) Q_L} \frac{1}{4} \left(\left[1 + \frac{\left(\frac{r}{Q}\right) Q_L I_{b0}}{V_{cav}} \cos \phi_b \right]^2 + \left[\frac{\Delta f}{f_{1/2}} + \frac{\left(\frac{r}{Q}\right) Q_L I_{b0}}{V_{cav}} \sin \phi_b \right]^2 \right)$$

Optimization for minimizing the klystron power required:

$$\begin{aligned} \frac{\Delta\omega_{opt}}{\omega} &= -\frac{\left(\frac{r}{Q}\right) I_{b0}}{2V_{cav}} \sin \phi_b \\ (Q_L)_{opt} &= \frac{V_{cav}}{\left(\frac{r}{Q}\right) I_{b0} \cos \phi_b} \\ (P_g)_{min} &= \frac{V_{cav}^2}{\left(\frac{r}{Q}\right) (Q_L)_{opt}} = V_{cav} \cdot I_{b0} \cdot \cos \phi_b \end{aligned}$$



Power Required as Function of Detuning

Example:

$V_{cav} = 25 \text{ MV}$, $Q_L = 3 \cdot 10^6$; no beam:

$$P_g = 50kW \cdot \left(1 + \left(\frac{\Delta f}{f_{1/2}} \right)^2 \right)$$

$V_{cav} = 25 \text{ MV}$, $Q_L = 3 \cdot 10^6$; $I_b = 8 \text{ mA}$; $\phi_b = 0^\circ$ (on-crest):

$$P_g = 50kW \cdot \left(4 + \left(\frac{\Delta f}{f_{1/2}} \right)^2 \right)$$



Flattop Power for Different Loaded Q and Detuning

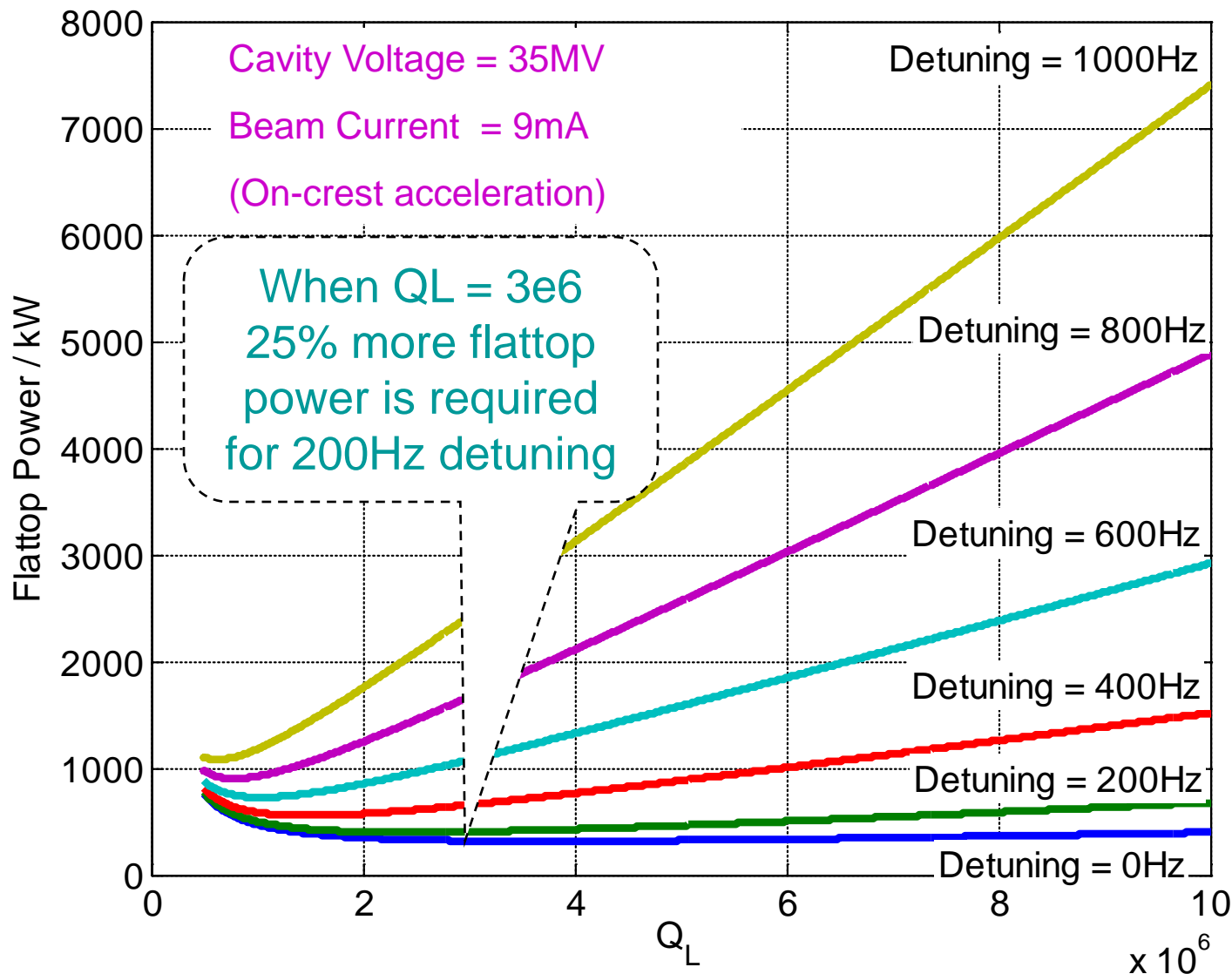

RF Power Reflection at Flattop Stage

- Energy conservation yields

$$P_{for} = P_{diss} + P_{ref} + P_{beam} + \frac{dW}{dt}$$

- For superconducting cavity, during flattop, the reflected power can be approximated as

$$P_{ref} = P_{for} - P_{beam} = P_{for} - \left| \vec{V}_c \right| \cdot I_{b0} \cos \varphi_b$$

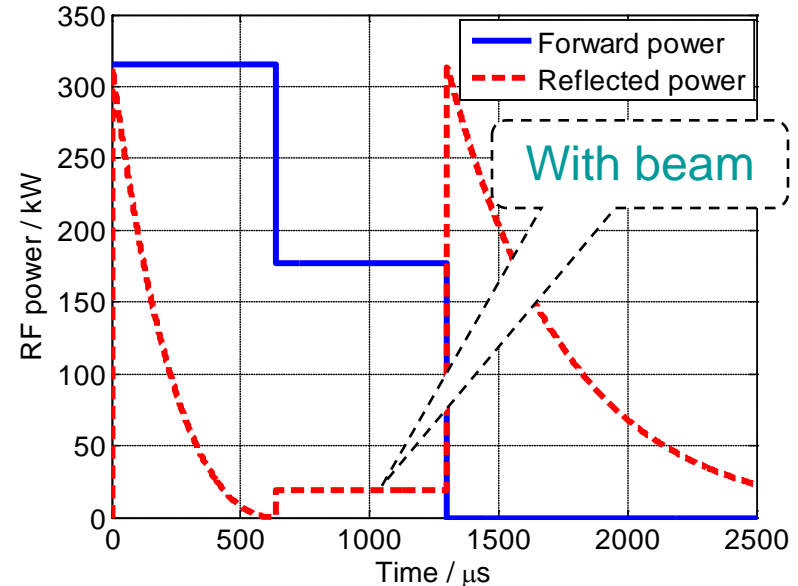
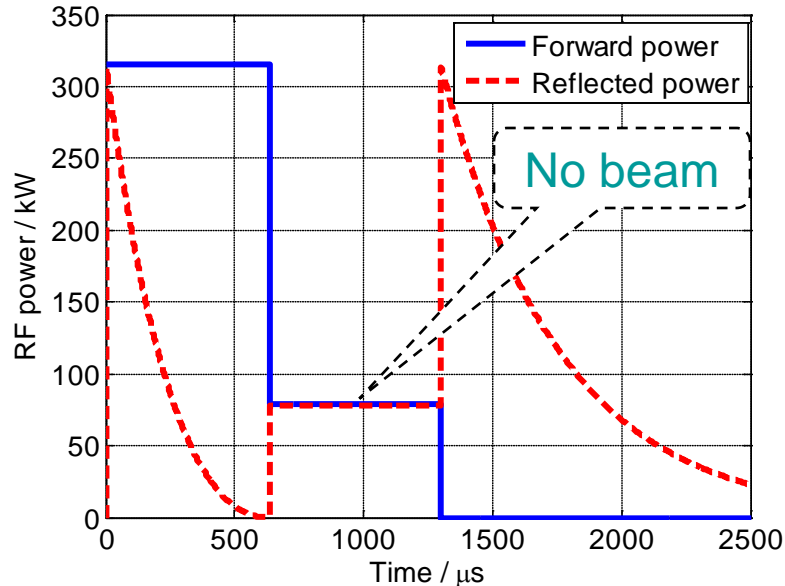



Ideas for Minimizing the Required Klystron Power

- Reduce the detuning effect
 - At filling stage, track the frequency of the input RF with the resonance frequency of the cavity
 - The pre-detuning of the cavity should be adjusted to minimize the average detuning during flattop
 - Piezo tuner can be used to compensate the Lorenz force detuning during flattop
- If there is beam, optimize the loaded Q, detuning and filling time
 - When the beam is large, optimize the loaded Q and detuning during the flattop with the equations in this section
 - When the beam is small, matching of the beam is not feasible, compromise should be made for the selection of the loaded Q and filling time

Mechanical Model of the Cavity

- Radiation pressure

$$P = \frac{(\mu_0 |\vec{H}|^2 - \epsilon_0 |\vec{E}|^2)}{4}$$

- Resonance frequency shift

$$\Delta f = -K \cdot E_{acc}^2$$

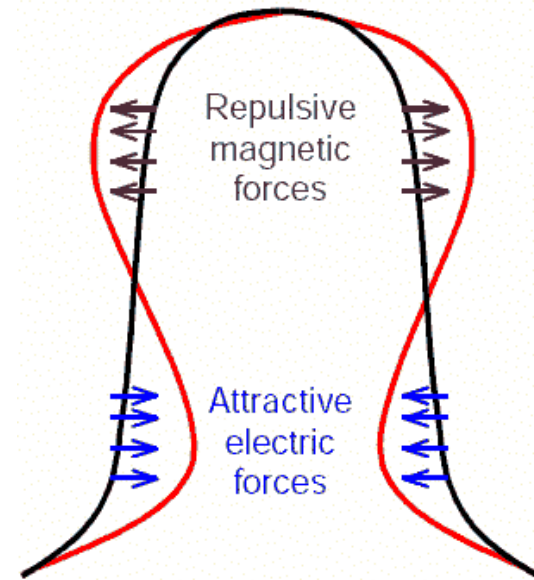

Static Lorenz Force Detuning

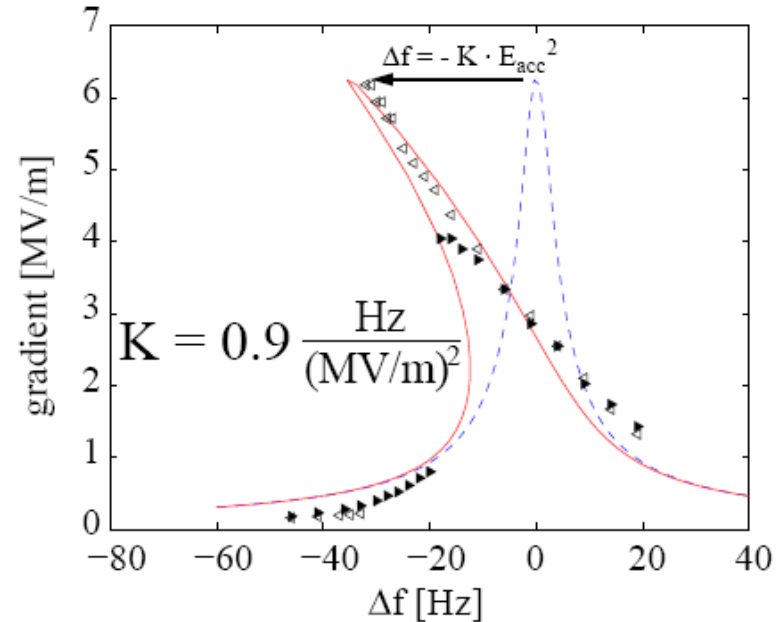
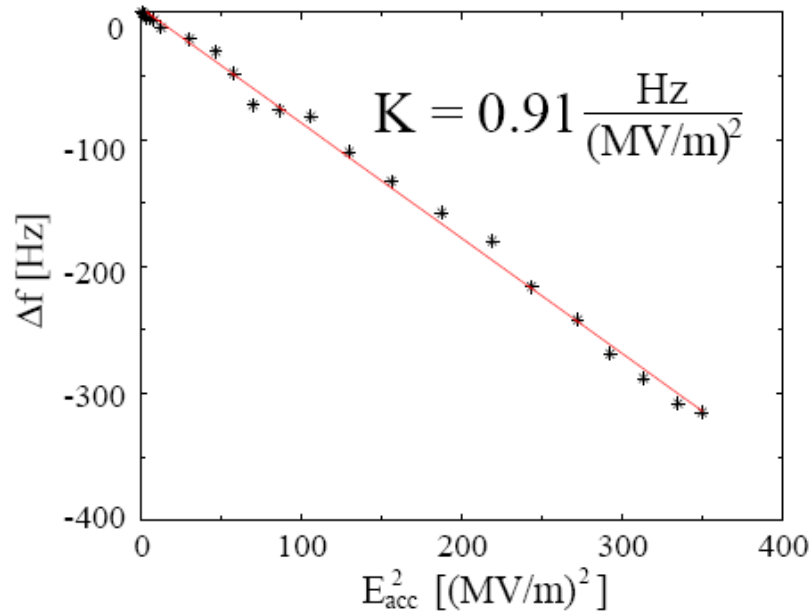

Left diagram: Measurement of Lorenz force parameter K .

Right diagram: Resonance curve of a superconducting cavity with Lorenz force detuning. The dotted curve is an ideal Lorentz curve. Depending on the gradient, the cavity resonance frequency is shifted in proportion to the square of the accelerating field E_{acc} . The measured points are indicated with triangles.

Dynamic Lorenz Force Detuning

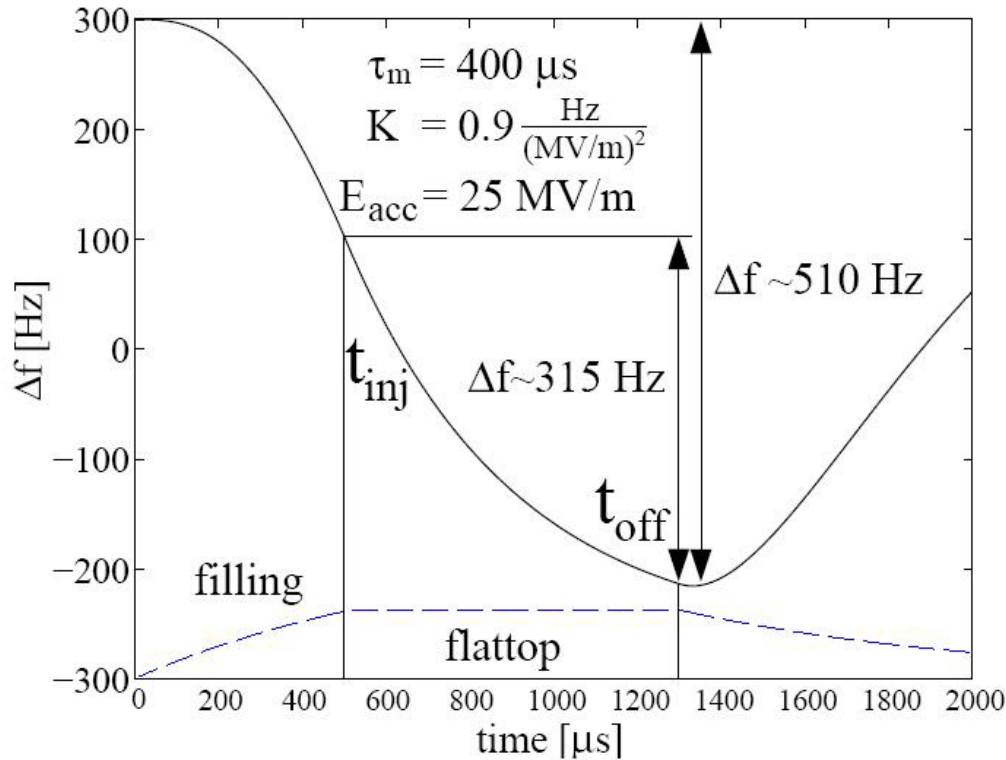

State space equation of the mth mechanical mode

$$\frac{d}{dt} \begin{bmatrix} \Delta\omega_m \\ \Delta\dot{\omega}_m \end{bmatrix} = \begin{bmatrix} 0 & 1 \\ -(2\pi f_m)^2 & -2\pi f_m / Q_m \end{bmatrix} \begin{bmatrix} \Delta\omega_m \\ \Delta\dot{\omega}_m \end{bmatrix} + 2\pi V^2 \begin{bmatrix} 0 \\ -K_m (2\pi f_m)^2 \end{bmatrix}$$

$$\Delta\omega = \Delta\omega_0 + \Delta\omega_0'(t) + \sum_{m=1}^N \Delta\omega_m$$

Pass Band Modes of the Cavity

- **Goal:** Model the cavity including the pass band modes by extending the π mode cavity equation discussed before

$$\frac{d\vec{V}_c}{dt} + (\omega_{1/2} - j\Delta\omega)\vec{V}_c = 2\omega_{1/2}\vec{V}_{for}$$

Circuit Model of the 9-Cell Cavity

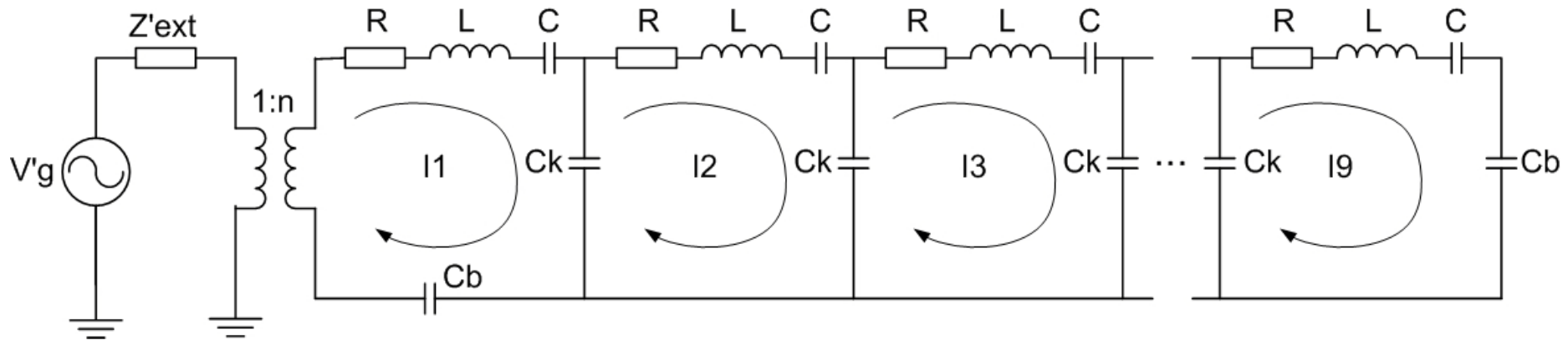
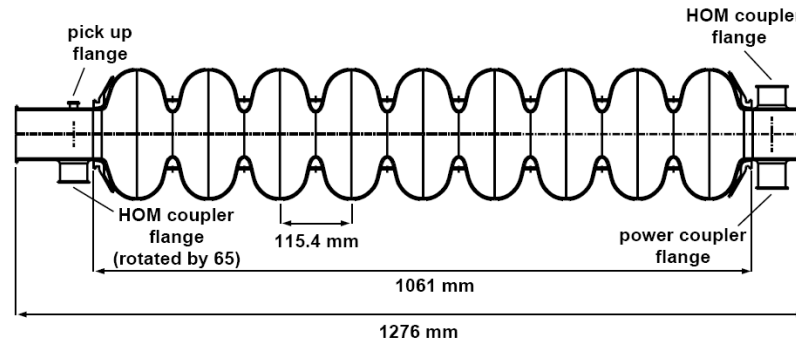

- Electrical coupled series resonance circuits driven by a voltage source
- Assume all cells are identical
- Cells are coupled via C_k
- Beam tube effect at the 1st and 9th cell is modeled with C_b

Steady State Equation of the Cavity

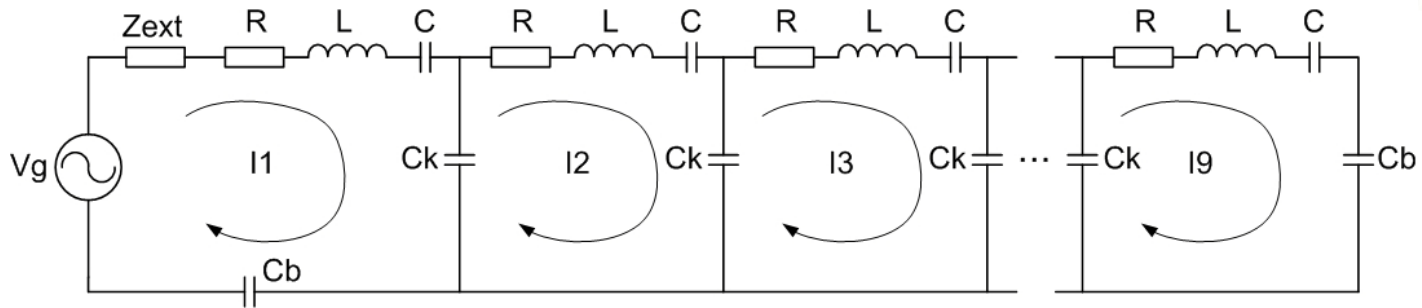

$$\begin{bmatrix}
 b + \kappa & -\frac{\kappa}{2} & 0 & \dots & 0 \\
 -\frac{\kappa}{2} & a & -\frac{\kappa}{2} & & \vdots \\
 0 & & \ddots & & \\
 \vdots & & & -\frac{\kappa}{2} & a & -\frac{\kappa}{2} \\
 0 & \dots & 0 & -\frac{\kappa}{2} & a + \frac{\kappa}{2}
 \end{bmatrix}
 \begin{bmatrix}
 I_1 \\
 I_2 \\
 \vdots \\
 I_8 \\
 I_9
 \end{bmatrix}
 =
 \begin{bmatrix}
 j\omega C V_g \\
 0 \\
 \vdots \\
 0 \\
 0
 \end{bmatrix}
 \quad \left| \quad \begin{aligned}
 a &= j \frac{\omega}{\omega_0 Q_0} - \frac{\omega^2}{\omega_0^2} + 1 + \kappa \\
 b &= j \frac{(\beta + 1)\omega}{\omega_0 Q_0} - \frac{\omega^2}{\omega_0^2} + 1 + \frac{\kappa}{2}
 \end{aligned}
 \right.$$

κ is the cell - to - cell coupling factor

ω is the driving frequency of V_g , ω_0 is the resonance frequency of the single cell

Q_0 is the unloaded quality factor of the single cell

β is the coupling factor of the input power coupler to the 1st cell



Frequency Response of the 9-Cell Cavity

Keep the driving voltage amplitude constant, change the frequency:

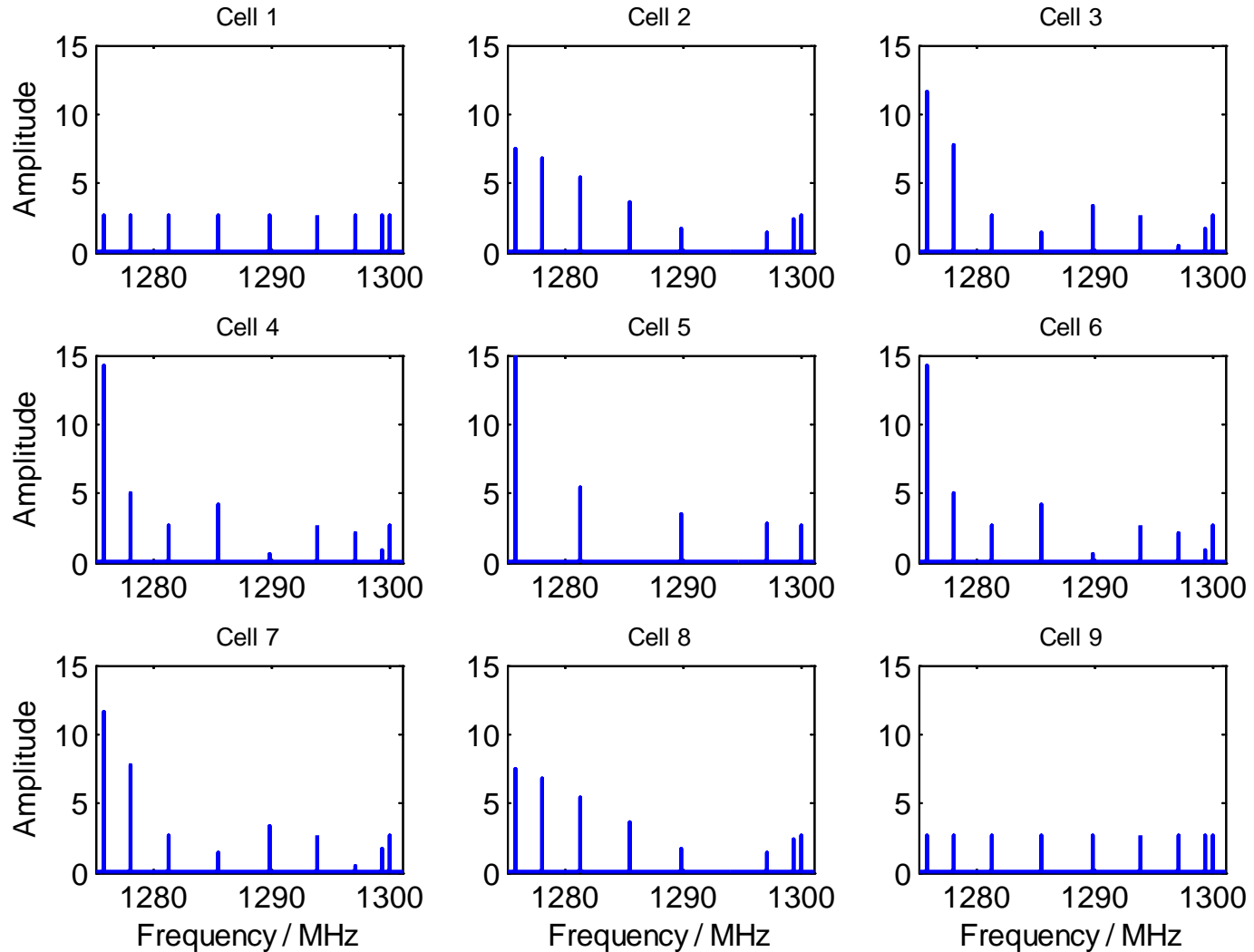

Pass band modes can be calculated by solving the eigenvalue problem by removing the driving term in the cavity equation, as results

Frequency of $n\pi/9$ mode:

$$\omega_{0,n\pi/9} = \omega_0 \cdot \sqrt{1 + \kappa \left[1 - \cos\left(\frac{n\pi}{9}\right) \right]}$$

Normalized field distribution in different cell of $n\pi/9$ mode :

$$I_{n\pi/9,m} = B_{n\pi/9} \sin\left[n\pi \left(\frac{2m-1}{18}\right)\right], \quad m = 1, 2, \dots, 9 \text{ is the cell number}$$

$$B_{n\pi/9} = \begin{cases} \sqrt{2/9} & \text{when } n = 1 \text{ to } 8 \\ \sqrt{1/9} & \text{when } n = 9 \end{cases}$$



Relative Field Distribution of Pass Band Modes

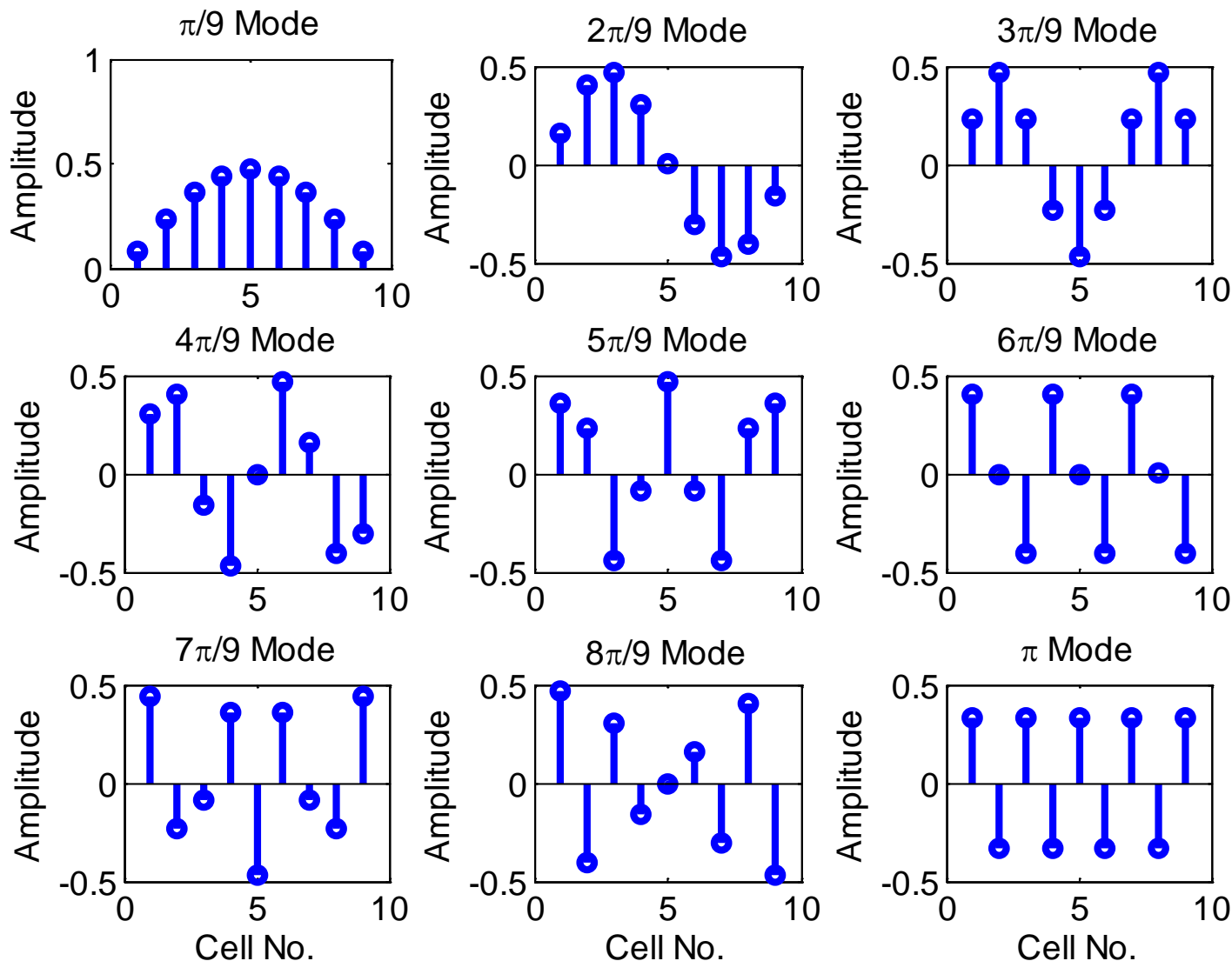

Quality Factor of Different Pass Band Modes

- For superconducting cavity, the internal power loss of the cavity can be neglected, so the loaded quality factor can be approximated to be

$$Q_{L,n\pi/9} \approx Q_{ext,n\pi/9} = \frac{\omega_{0,n\pi/9} U_{n\pi/9}}{P_{ext,n\pi/9}}$$

- From the normalized field distribution of the pass band modes, the effective stored energy in the cavity for each pass band mode is the same.

$$\sum_{m=1}^9 I_{n\pi/9,m}^2 = 1 \Rightarrow U_{n\pi/9} \text{ is identical}$$

- If we ignore the difference of the resonance frequency, the loaded quality factor of each mode is inversed proportional to the stored energy in the first cell, use the loaded quality factor in π mode as reference, we get

$$\frac{Q_{L,n\pi/9}}{Q_{L,\pi}} = \frac{I_{\pi,1}^2}{I_{n\pi/9,1}^2} = \frac{1}{2 \sin^2\left(\frac{n\pi}{18}\right)}, \quad n = 1, 2, \dots, 8$$

For example, the QL for the $\pi/9$ mode is 16 times larger than the QL for π mode

Field in the 9th Cell

- Field in the 9th cell is important because the probe is installed there
- The field for different pass band modes in the 9th cell has the property of
 - Have the same amplitude to the same input power
 - The phase difference of the nearest pass band modes is 180 degree
 - The loaded Qs are different

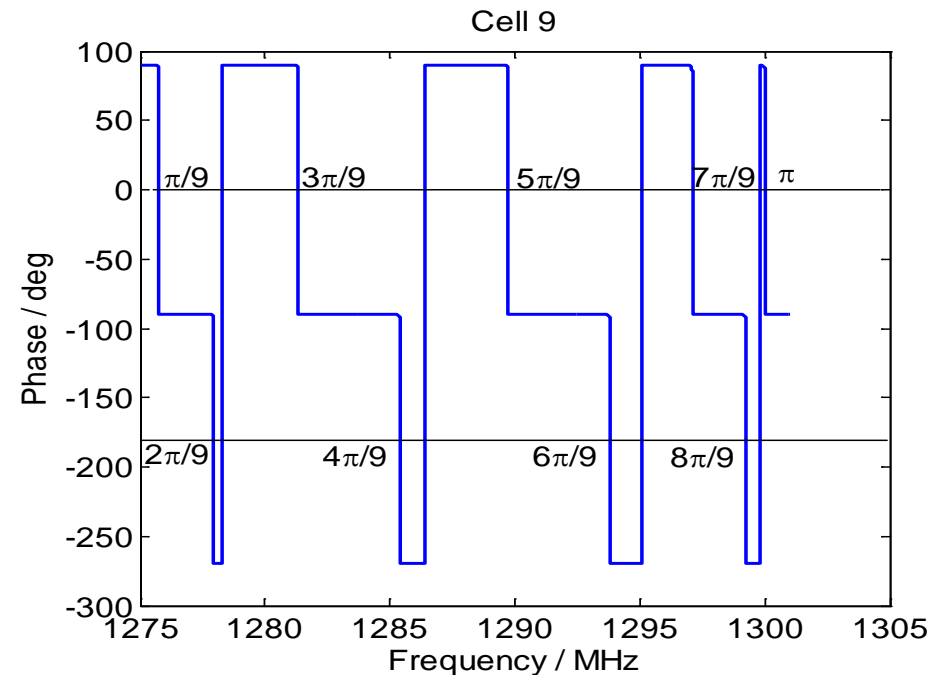
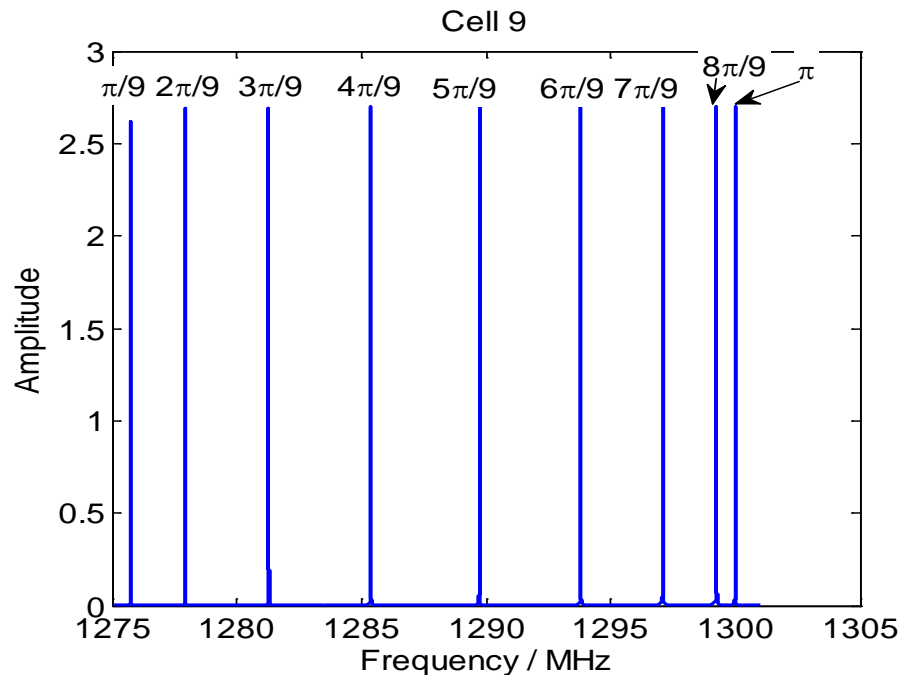

Cavity Model with Pass Band Modes

- Based on the π mode model discussed before, the cavity model with pass band modes can be made as follows
 - Each pass band mode is modeled with a base band equation similar with the π mode
 - The driving term of all pass band modes are the same for the same input power
 - Different pass band mode has different bandwidth
 - The overall cavity voltage is the superposition of the voltage of all the pass band modes, use the equations below

$$\frac{d\vec{V}_{c,n\pi/9}}{dt} + \left(\omega_{1/2,n\pi/9} - j\Delta\omega_{n\pi/9} \right) \vec{V}_{c,n\pi/9} = 2\omega_{1/2,n\pi/9} \vec{V}_{for}, \quad n = 1, 2, \dots, 9$$

$$\vec{V}_c = \sum_{n=1}^9 (-1)^{n-1} \vec{V}_{c,n\pi/9}$$

Here we have considered the phase difference of pass band modes in the 9th cell

$\Delta\omega_{n\pi/9} = \omega_{0,n\pi/9} - \omega$ is the detuning of the $n\pi/9$ mode

$\omega_{1/2,n\pi/9}$ is the half bandwidth of the $n\pi/9$ mode

Transfer Function of the Cavity

- From the cavity equations, the transfer function of the cavity is

$$H_{cav}(s) = \sum_{n=1}^9 (-1)^{n-1} H_{n\pi/9}(s) = \sum_{n=1}^9 (-1)^{n-1} \frac{2\omega_{1/2, n\pi/9}}{s + \omega_{1/2, n\pi/9} - j\Delta\omega_{n\pi/9}}$$

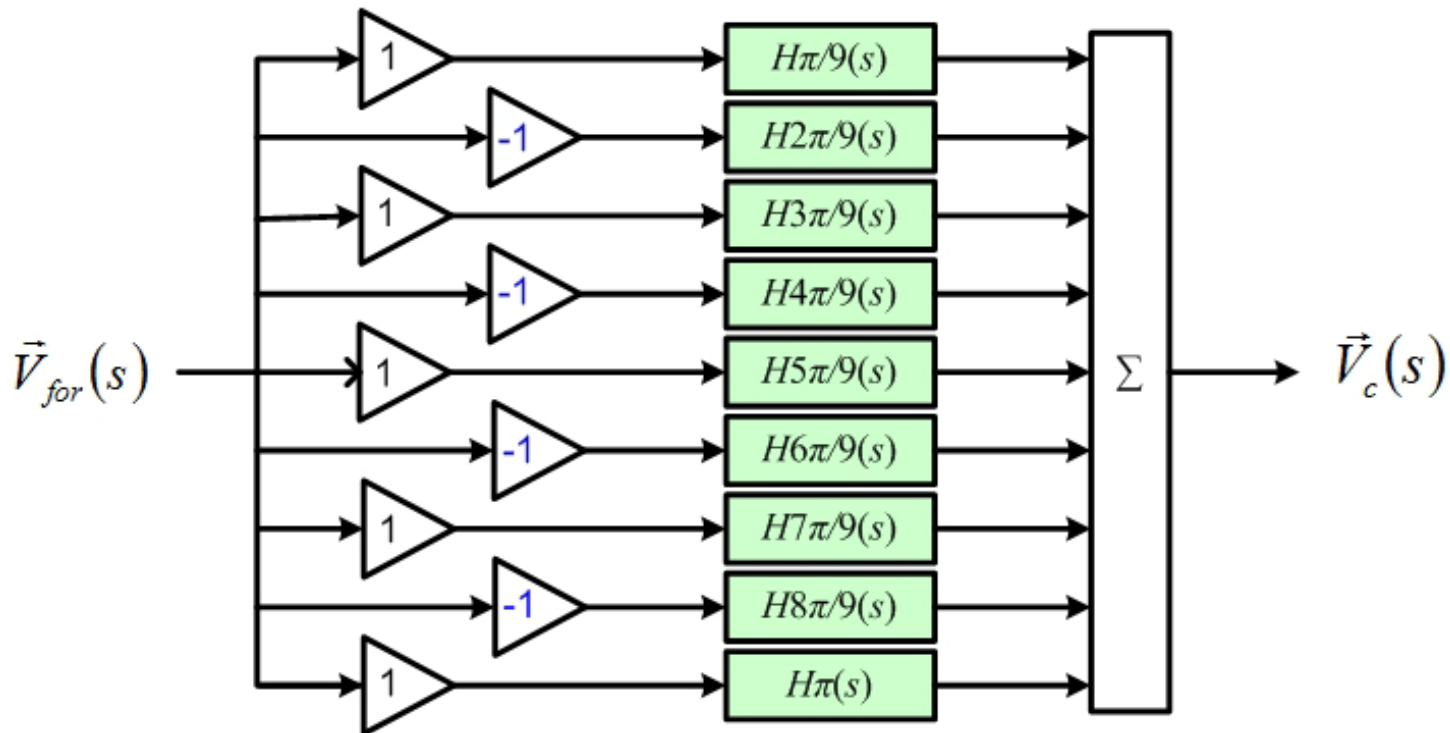



Bode Plot of the Cavity Transfer Function

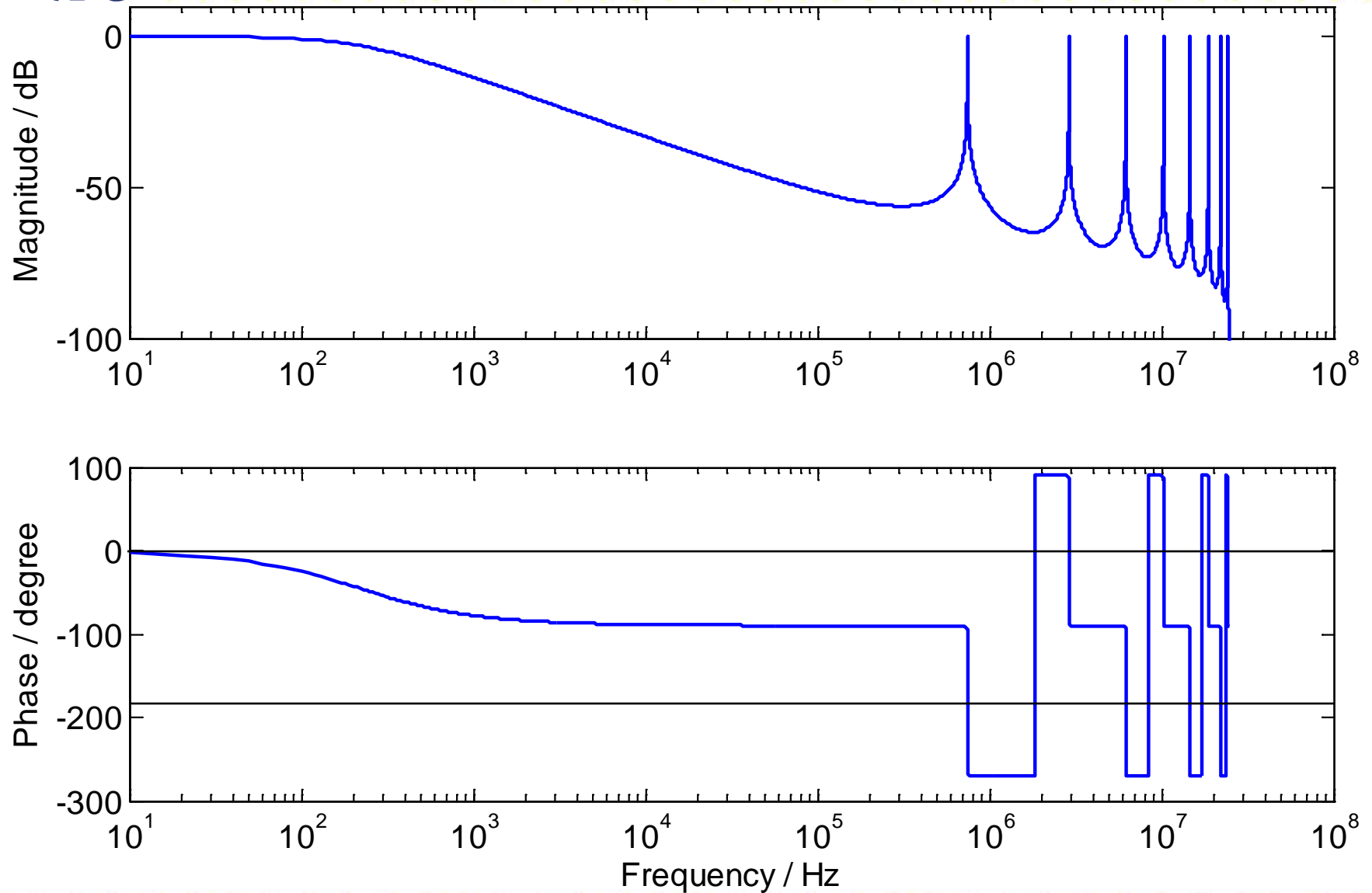

Cavity Simulator

Cavity Simulator

- Idea: build a hardware cavity simulator to simulate the cavity behavior including the Lorenz force detuning
- Use cases:
 - Test the LLRF hardware such as down converter, controller and actuator before the real cavity is ready
 - Control algorithm study
 - Operator training
 - LLRF system on-line calibration if integrated with working system

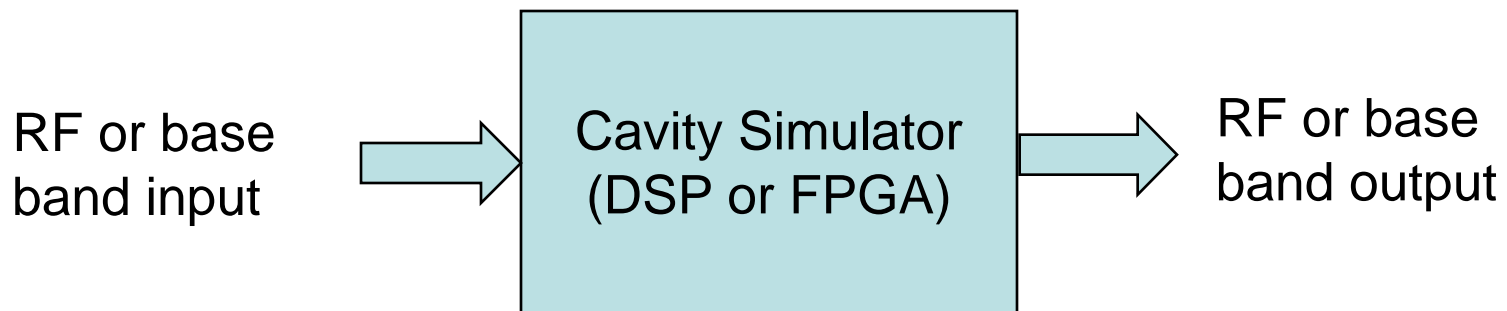



Possible Cavity Simulator Integration with LLRF

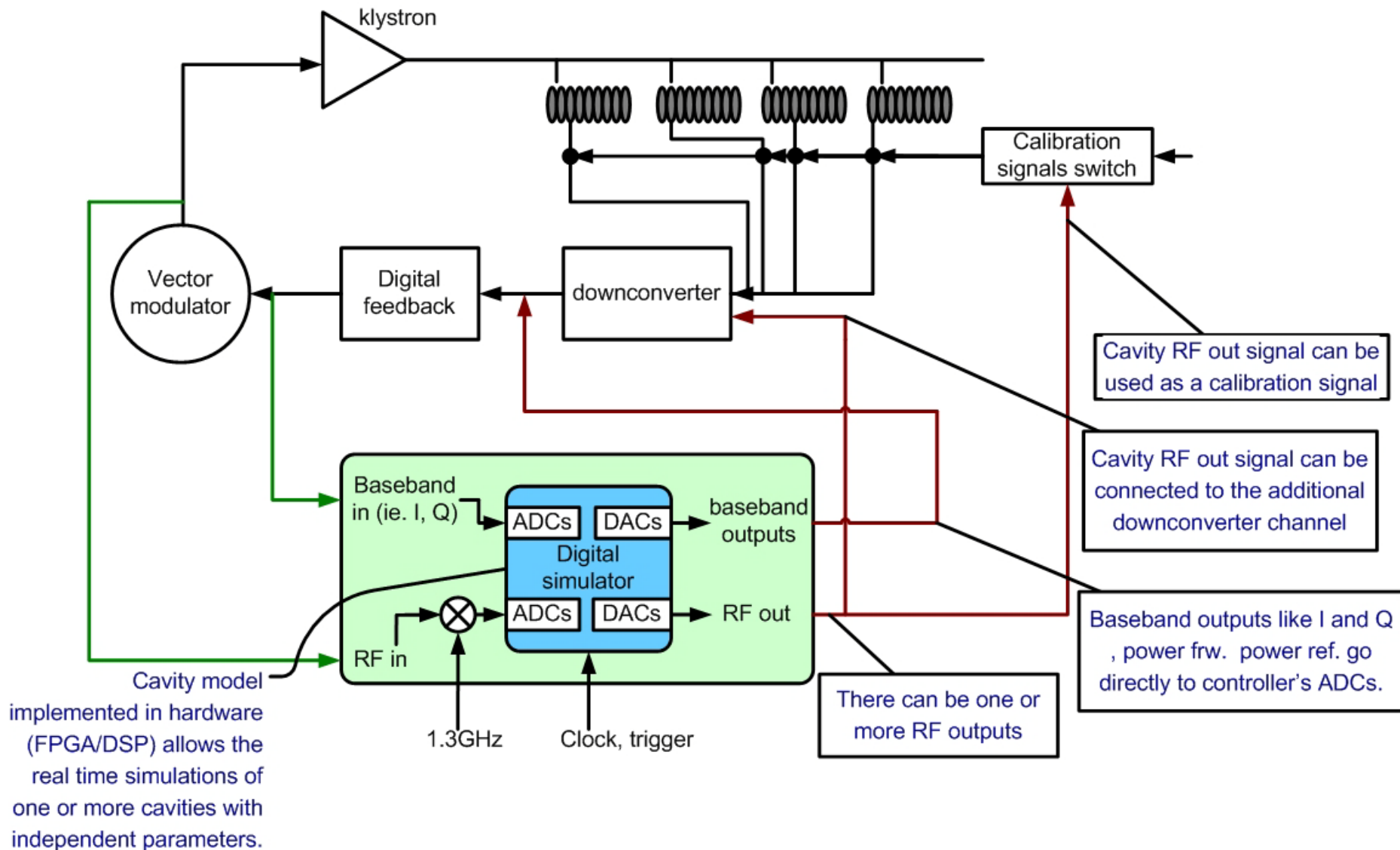

Discrete Cavity Equation

$$\frac{d\vec{V}_c}{dt} + (\omega_{1/2} - j\Delta\omega)\vec{V}_c = \omega_{1/2}R_L\vec{I}$$



(state space equation)

$$\frac{d}{dt} \begin{bmatrix} V_r \\ V_i \end{bmatrix} = \begin{bmatrix} -\omega_{1/2} & -\Delta\omega \\ \Delta\omega & -\omega_{1/2} \end{bmatrix} \begin{bmatrix} V_r \\ V_i \end{bmatrix} + \omega_{1/2}R_L \begin{bmatrix} I_r \\ I_i \end{bmatrix}, \quad \vec{V}_c = V_r + jV_i, \vec{I} = I_r + jI_i$$



(discrete)

$$\begin{bmatrix} V_{r,n} \\ V_{i,n} \end{bmatrix} = \begin{bmatrix} 1 - T\omega_{1/2} & -T\Delta\omega \\ T\Delta\omega & 1 - T\omega_{1/2} \end{bmatrix} \begin{bmatrix} V_{r,n-1} \\ V_{i,n-1} \end{bmatrix} + T\omega_{1/2}R_L \begin{bmatrix} I_{r,n-1} \\ I_{i,n-1} \end{bmatrix}$$

T is the sampling period. The discrete equation can be realized in digital processors, such as FPGA, for simulation

Lorenz force detuning by the m th mechanical mode:

$$\frac{d}{dt} \begin{bmatrix} \Delta\omega_m \\ \Delta\dot{\omega}_m \end{bmatrix} = \begin{bmatrix} 0 & 1 \\ -(2\pi f_m)^2 & -\frac{2\pi f_m}{Q_m} \end{bmatrix} \begin{bmatrix} \Delta\omega_m \\ \Delta\dot{\omega}_m \end{bmatrix} + 2\pi V^2 \begin{bmatrix} 0 \\ -K_m (2\pi f_m)^2 \end{bmatrix}$$



(discrete)

$$\begin{bmatrix} \Delta\omega_{m,n} \\ \Delta\dot{\omega}_{m,n} \end{bmatrix} = \begin{bmatrix} 1 & T' \\ -T'(2\pi f_m)^2 & 1 - T' \frac{2\pi f_m}{Q_m} \end{bmatrix} \begin{bmatrix} \Delta\omega_{m,n-1} \\ \Delta\dot{\omega}_{m,n-1} \end{bmatrix} - 2\pi T' K_m (2\pi f_m)^2 \begin{bmatrix} 0 \\ V^2 \end{bmatrix}$$



(sum up)

$$\Delta\omega = \Delta\omega_0 + \Delta\omega_0'(t) + \sum_{m=1}^N \Delta\omega_m$$

Cavity Simulator Block Diagram

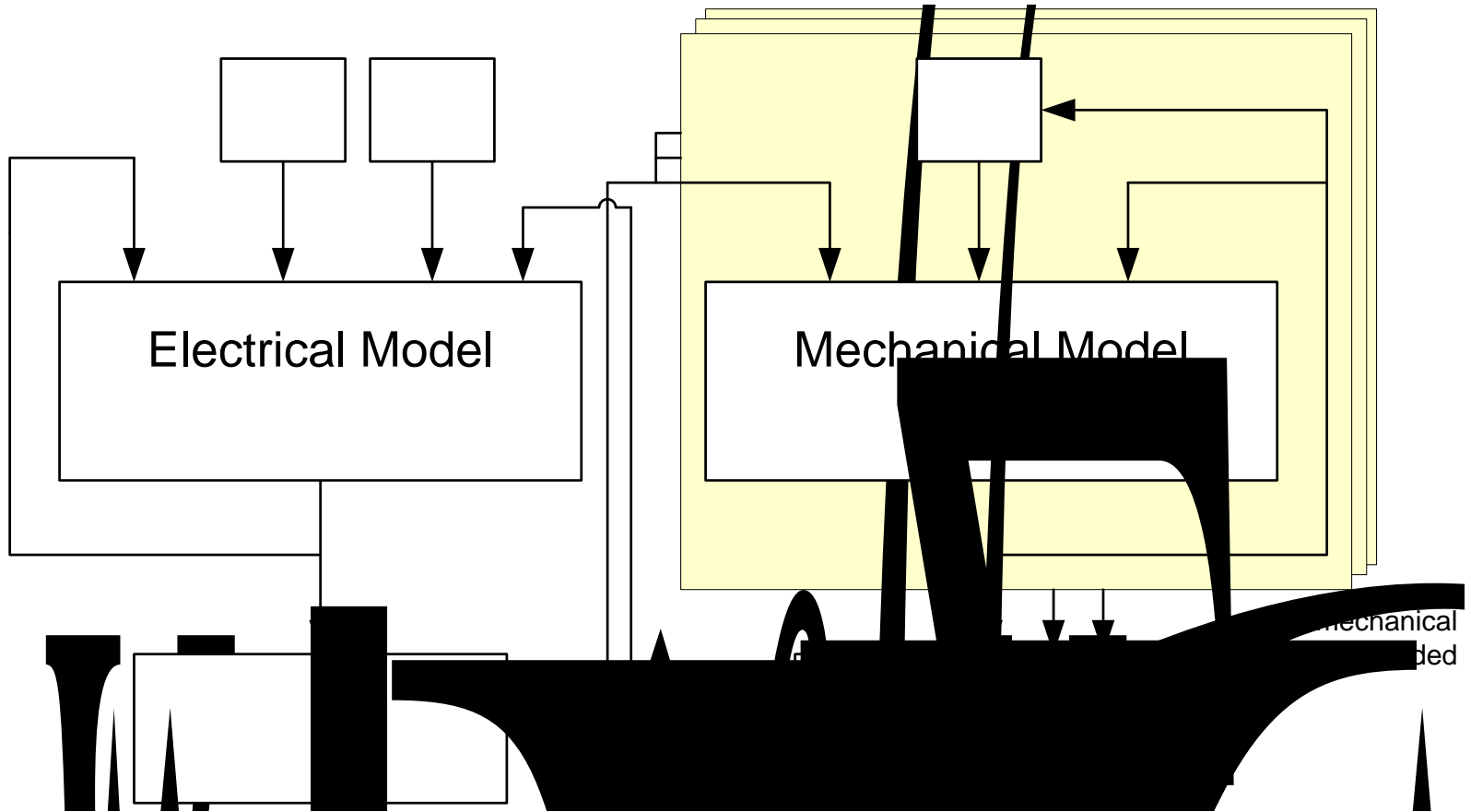

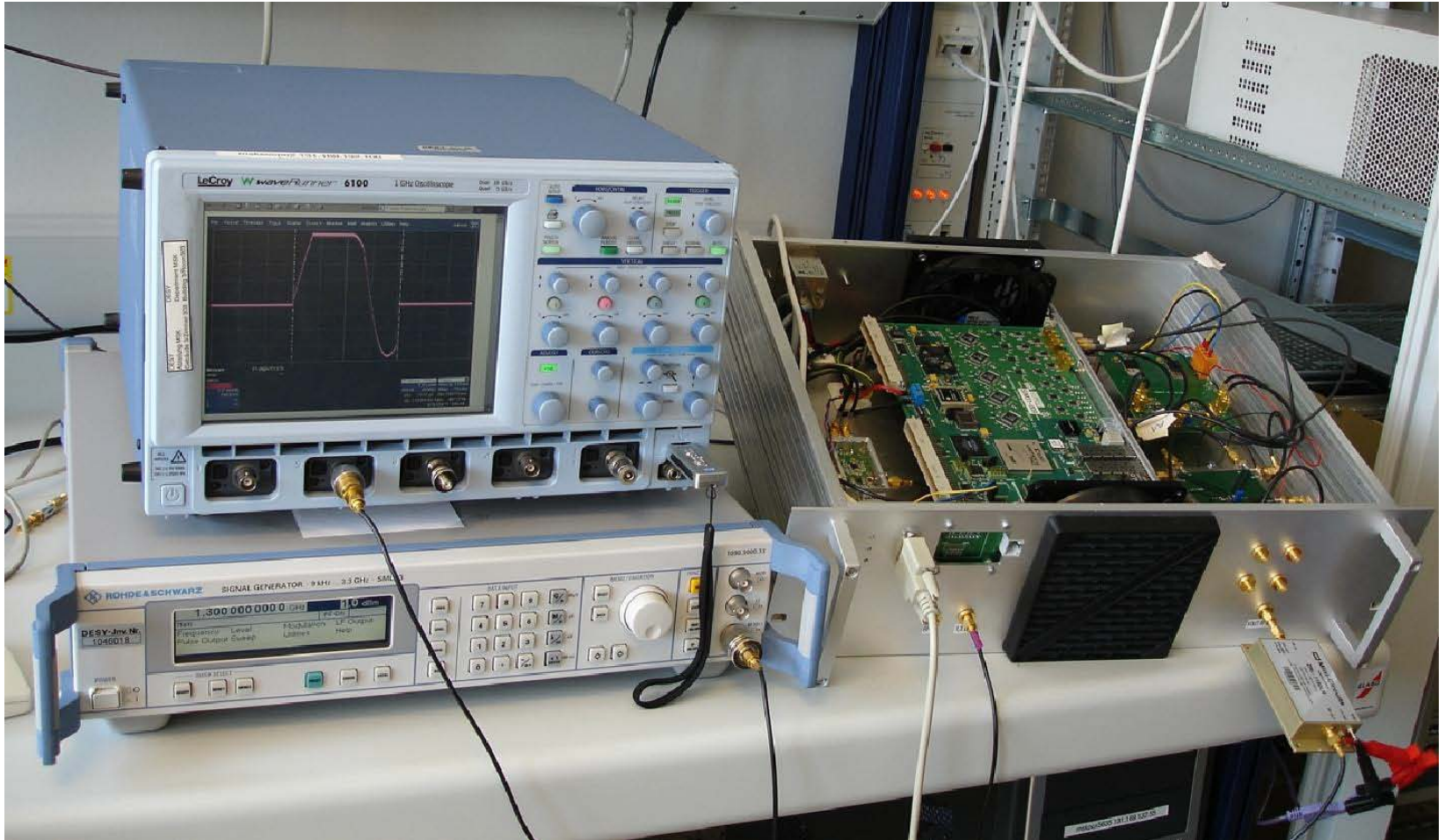

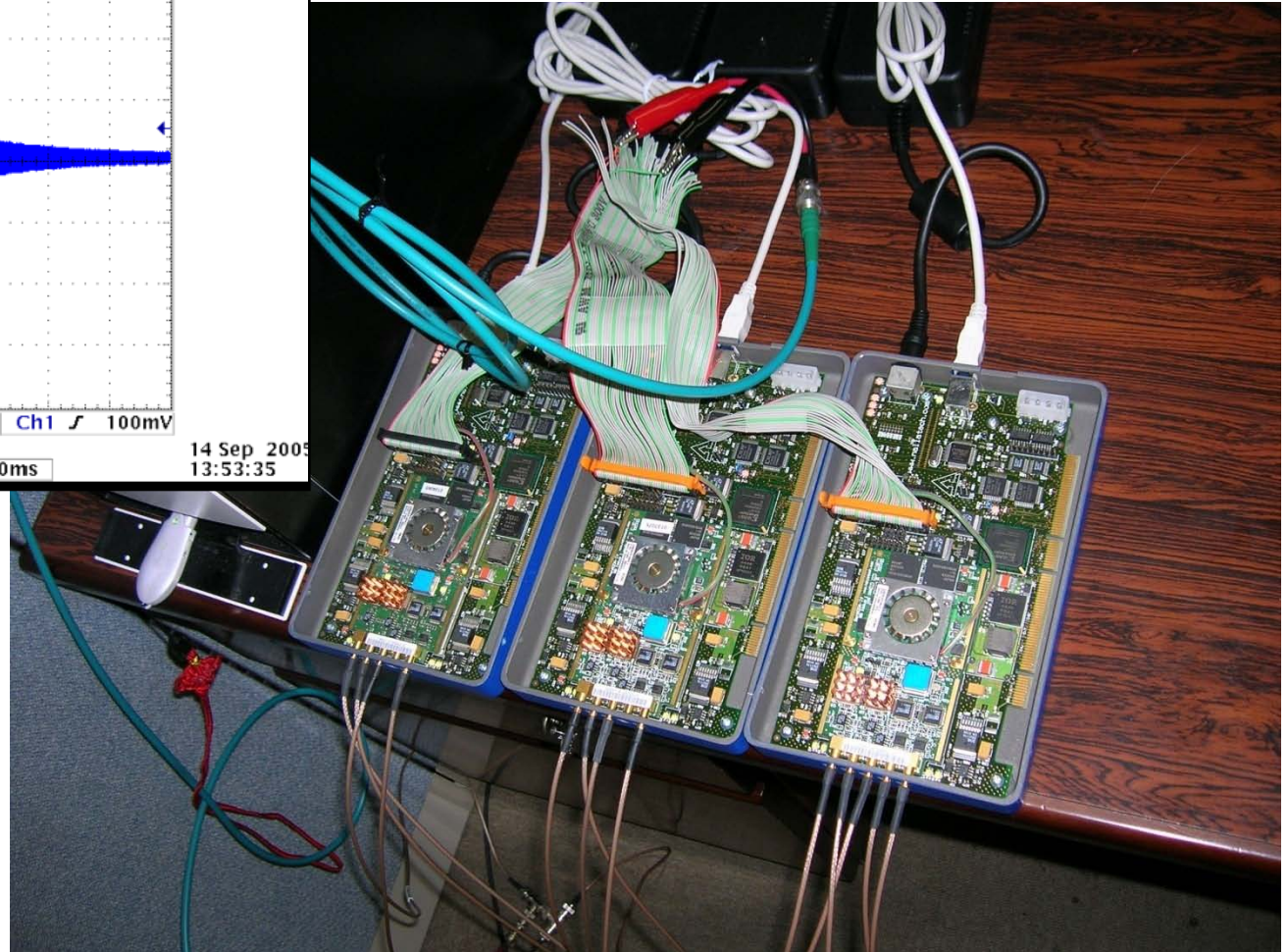
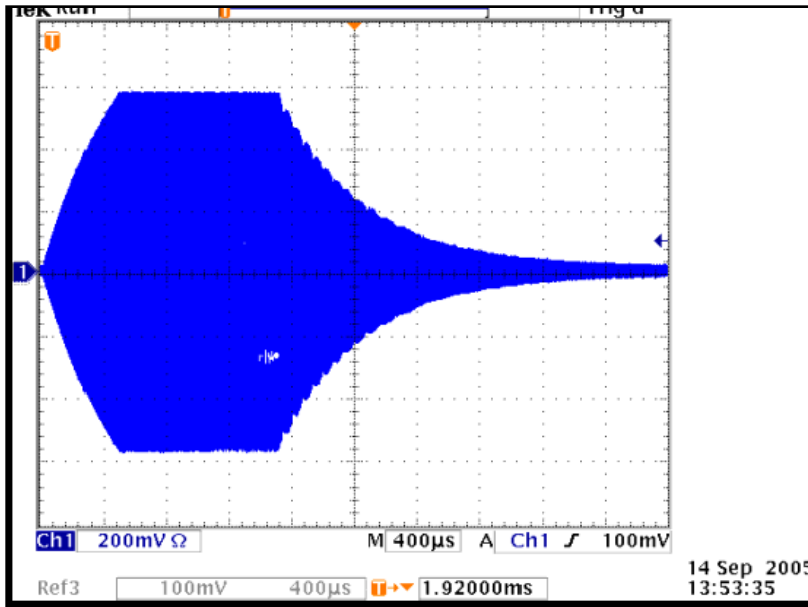



Software Real Time Cavity Simulator at Fermilab

Test run of ILC Cavity Simulator (no beam)

- 1) fill: 0 - 0.3 ms at 20 mA (full power)
- 2) flat-top: 0.3 - 1.1 ms at 12 mA
- 3) cavity emptying, decay curve shows high Q of cavity.

Compare with
TESLA cavity
measurements:
**Shapes are similar,
model is working.**

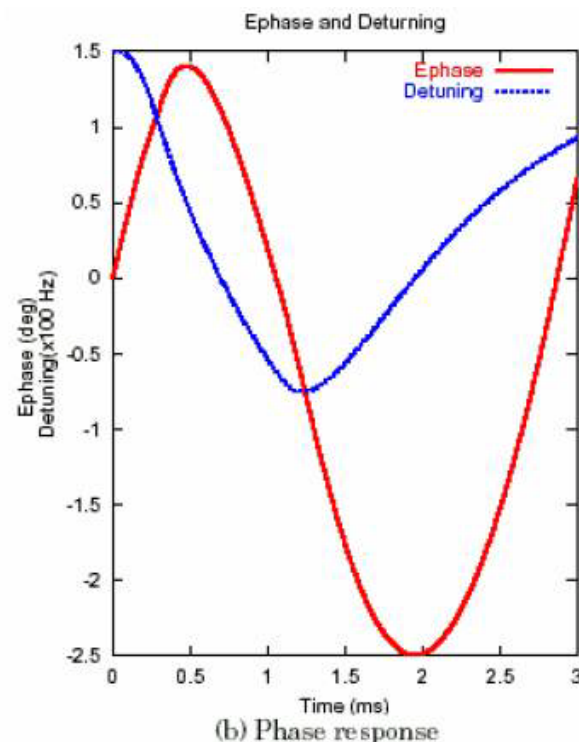
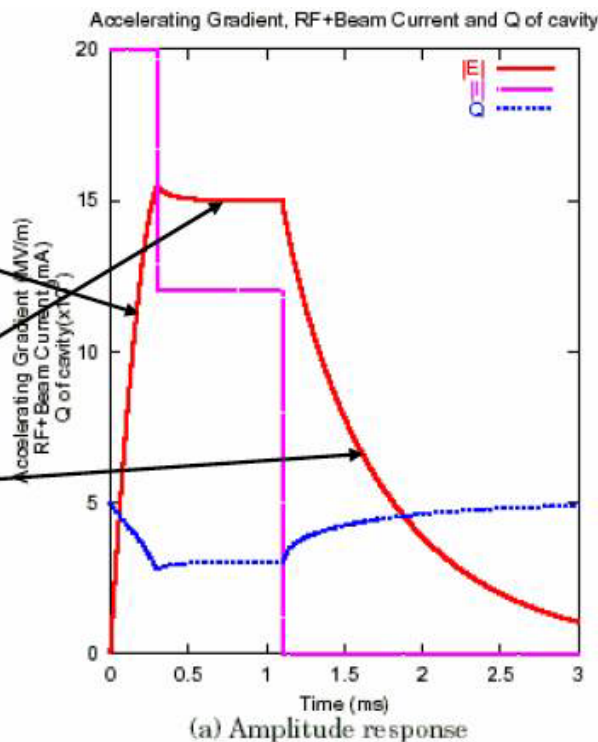

IF in these simulations is 50 MHz.

In this part, we have learnt:

- Model the cavity with resonance circuits
- Baseband equations for cavity model
- RF power dissipation and reflection of a cavity
- Mechanical model of the cavity
- Pass band modes model of the cavity
- Concept for cavity simulator

- [1] E. Vogel. High Gain Proportional RF Control Stability at TESLA Cavities. Physical Review Special Topics – Accelerators and Beams, 10, 052001 (2007)
- [2] T. Schilcher. Vector Sum Control of Pulsed Accelerating Fields in Lorentz Force Detuned Superconducting Cavities. Ph. D. Thesis of DESY, 1998
- [3] A. Brandt. Development of a Finite State Machine for the Automated Operation of the LLRF Control at FLASH. Ph.D. Thesis of DESY, 2007
- [4] H. Padamsee, J. Knobloch, et.al. RF Superconductivity for Accelerators. John Wiley & Sons, Inc. 1998
- [5] W.M. Zabolotny et al. Design and Simulation of FPGA Implementation of RF Control System for TESLA Test Facility. TESLA Report 2003-05, 2003