

# Cavity Field Control

## - RF Field Controller

LLRF Lecture Part 3.3

S. Simrock, M. Grecki

ITER / DESY

A horizontal dotted line in a light yellow-green color is located at the bottom of the slide, mirroring the one at the top.

- Introduction to the controller
- Control scheme selection
  - In-phase and Quadrature (I/Q) control **VS** Amplitude and Phase (A&P) control
  - Vector sum control **VS** individual cavity control
  - Analog control **VS** digital control
  - Generator Driven Resonator (GDR) control
  - Self-Excited Loop (SEL) control
  - Phase Locked Loop (PLL) control
- A concept for universal controller

# Introduction to the Controller



# RF Field Controller

- Use cases:
  - Maintain amplitude and phase stability of the cavity field
  - Support lossless beam transfer when the machine starts
  - Provide arbitrary RF pulse shape for system calibration
  - ...

# Feedback and Feed Forward

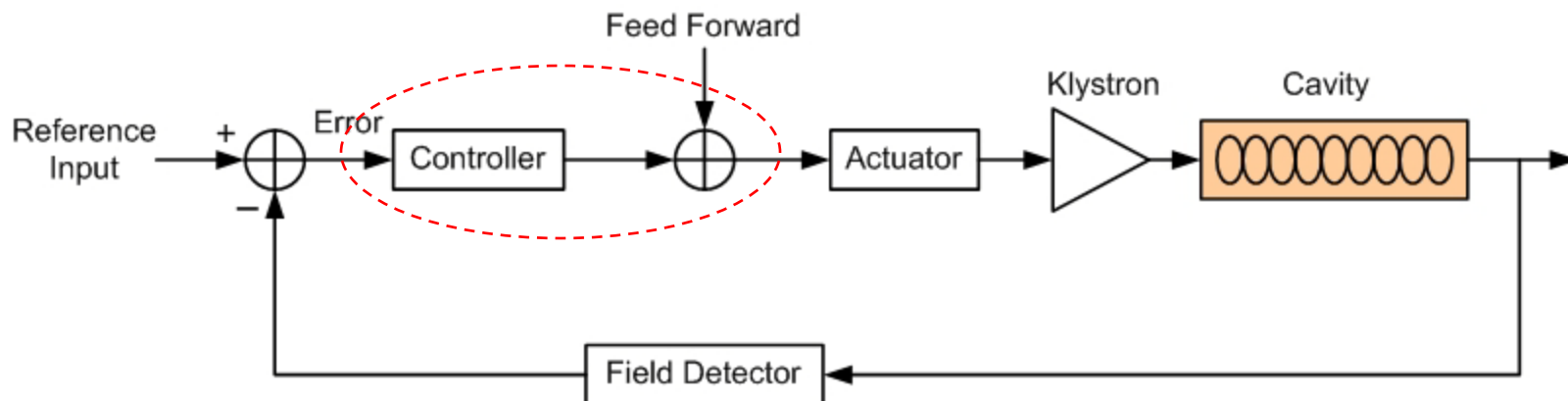

- **Feedback:** compensate the random errors (phase jitter caused by klystron high voltage jitter, microphonics, bunch charge fluctuations)
- **Feed forward:** compensate the repetitive errors (Lorenz force detuning)



# Cavity Field Regulation (Simulation)

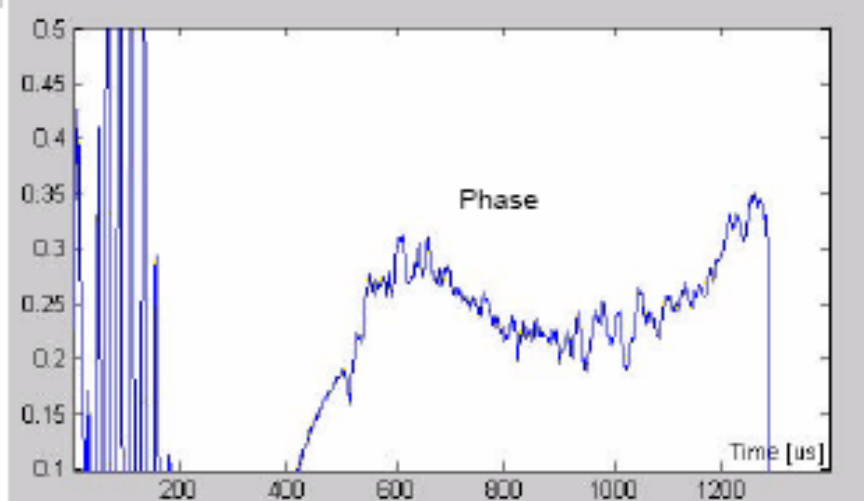
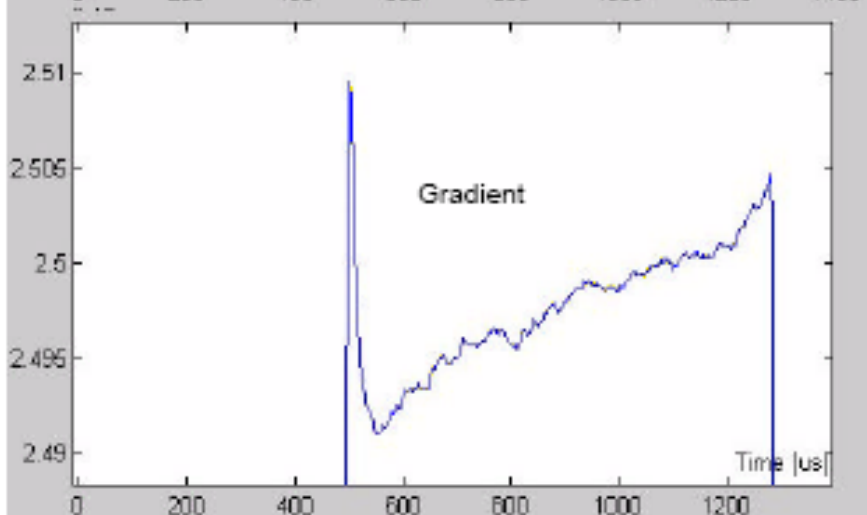
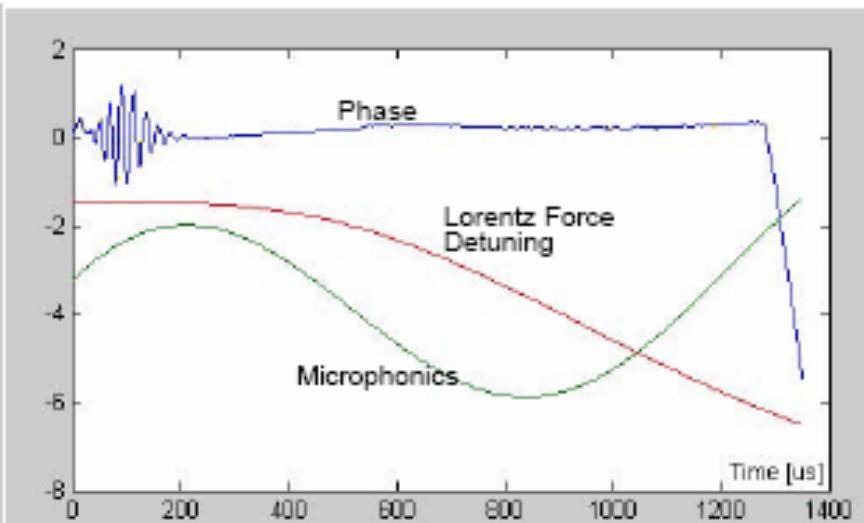
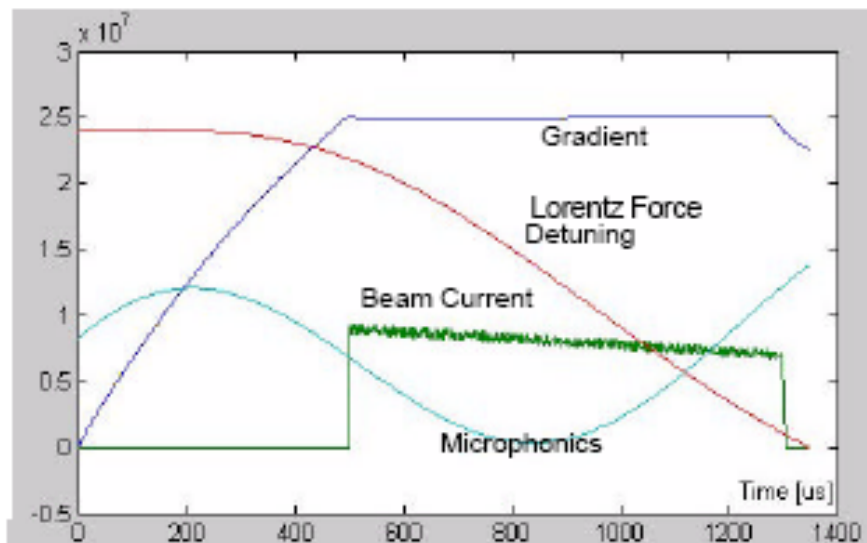

# Control Scheme Selection

# I/Q Control VS A&P Control

- **A&P Control:** control the amplitude and phase of the cavity field separately
- **I/Q Control:** control the I and Q components of the cavity field separately

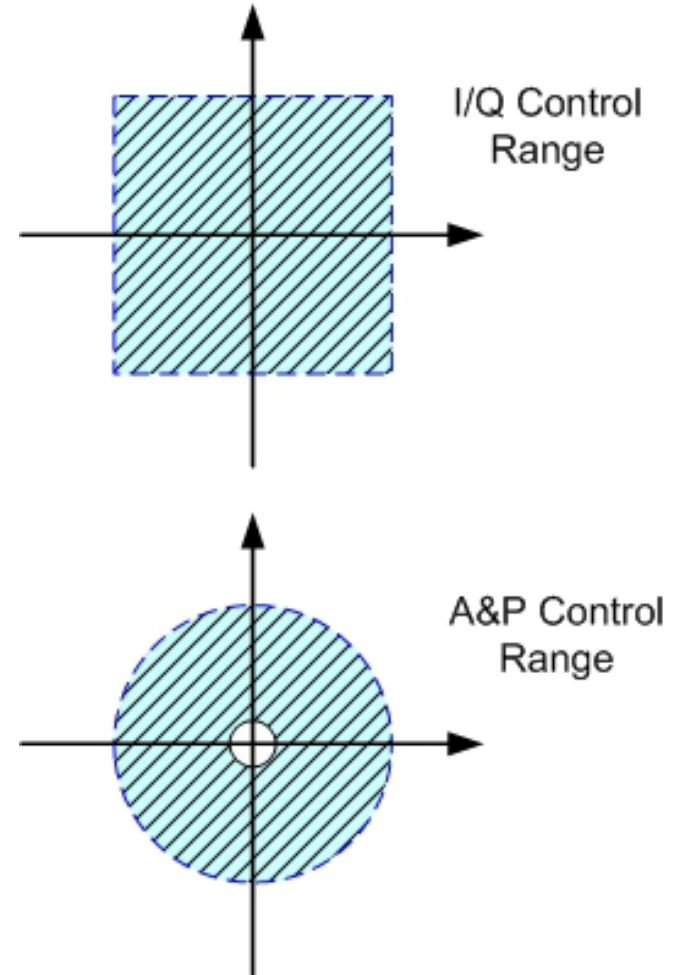
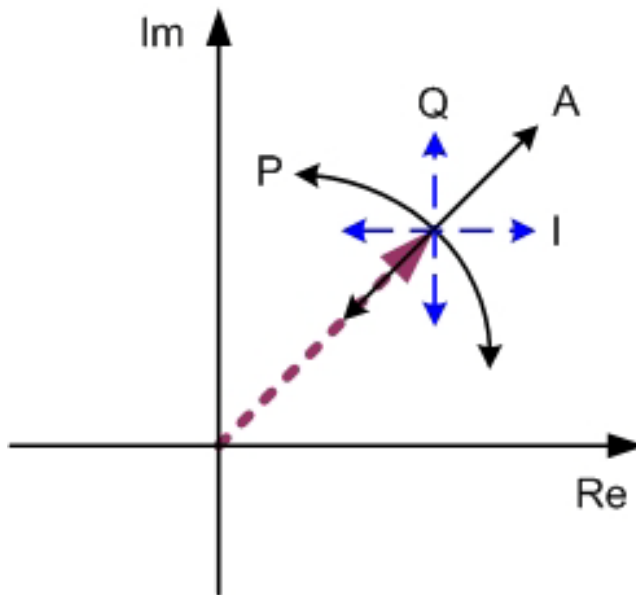





# I/Q Control VS A&P Control

- I/Q control
  - Set point can cover the four quadrants including zero
  - Good for the control of large errors and large beam loading
  - Coupling between I/Q channels if the loop phase is wrong
  - Noise of I/Q detector more than Schottky diode (amplitude detector)
- A&P control
  - Less noise for amplitude measurement
  - No loop phase problem
  - If there is large phase error, the cavity output may be driven to wrong quadrants



# Vector Sum Control VS Individual Cavity Control

For vector sum control:

Benefit:

- Significant **cost savings**
- Maintenance reduced
- Less units to be controlled

Disadvantage:

- **Calibration of vector-sum** challenging
- Can not **operate** each cavity at individual **limit**
- RF power distribution must be precise (power, phase)
- **By-passing** of individual cavities more difficult

# Analog Control VS Digital Control

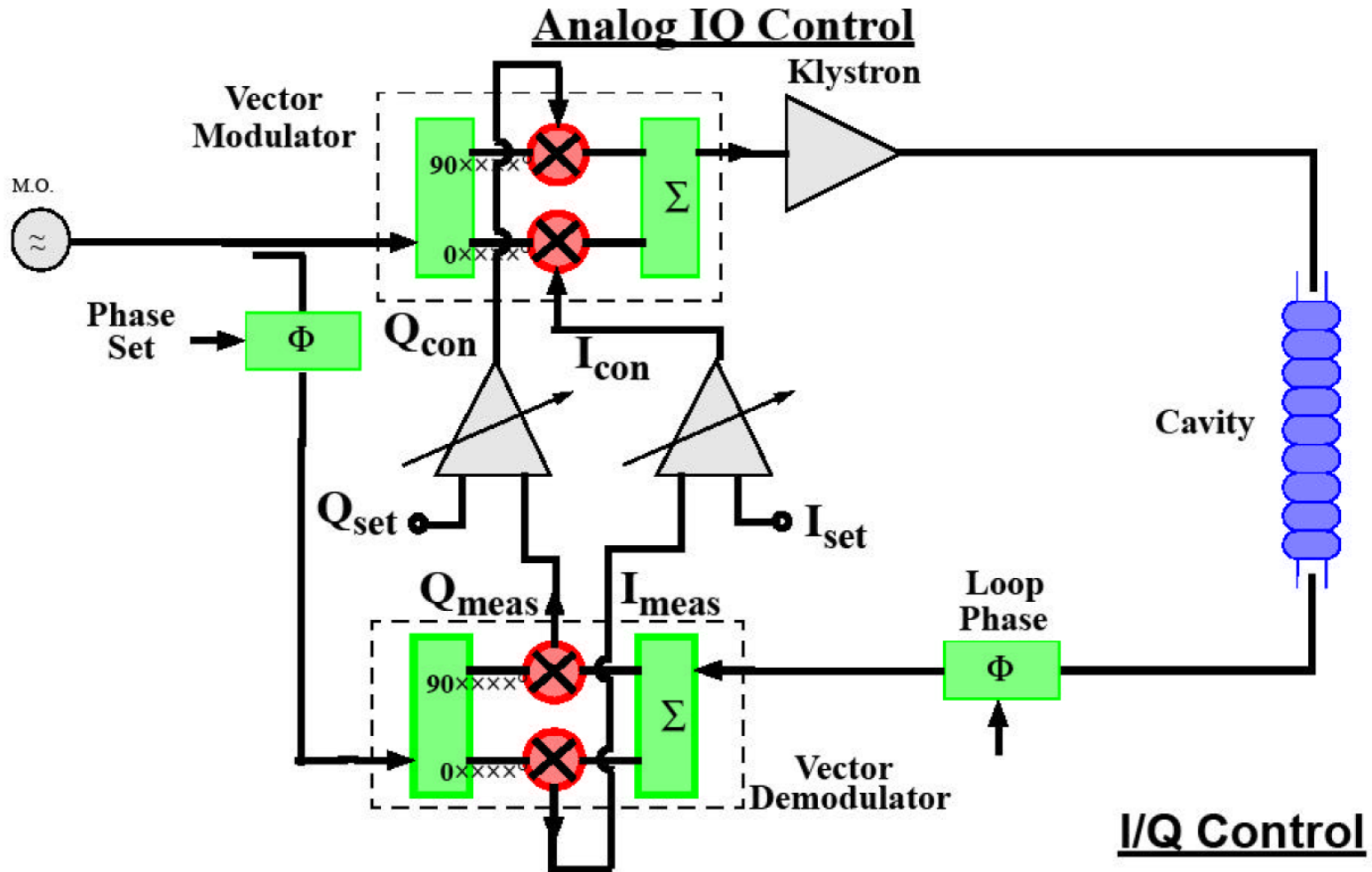

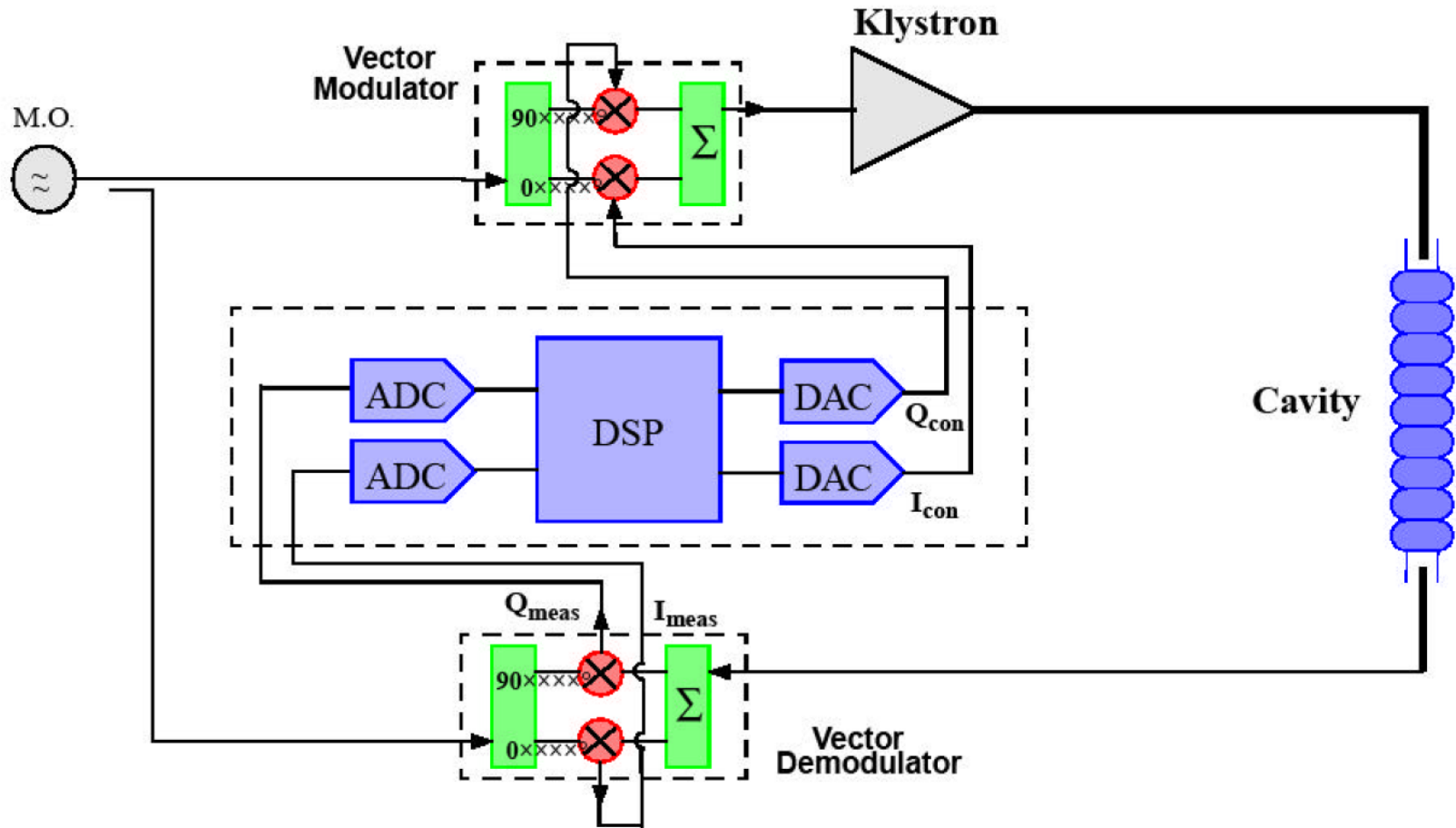



# Analog Control VS Digital Control

- Analog control
  - Minimum delay and lower noise
  - Simplicity and straightforward
  - Better diagnostics with analog scopes
  - Less resources for R&D
- Digital control
  - Flexibility for arbitrary set points
  - Digital I/Q detection for measurement of RF field vector and forward and reflected wave
  - Robust and flexible feedback algorithms (optimal controller)
  - Feed forward control can be added easily
  - Build in diagnostics
  - Need for automated operation such as fault recovery and changing beam energy
  - High level applications support (example: automated cavity tuning)
  - Exception handling (example: recovery from cavity quench)
  - Less drift
  - Introduces additional delays
  - Higher noise due to ADCs
  - More sensitive to EMI
  - Component lifetime limited
  - Aging

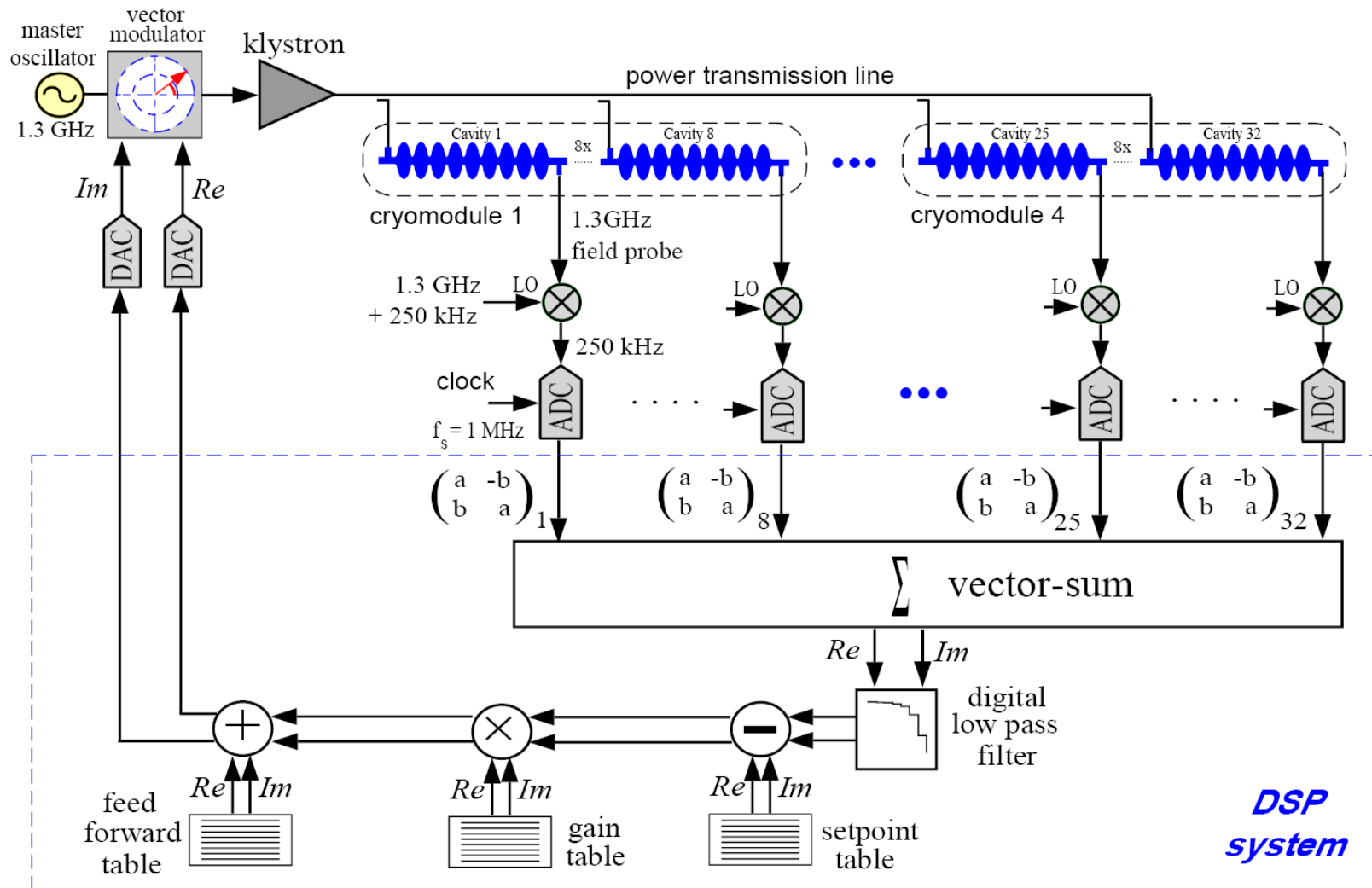

# GDR Control VS SEL Control

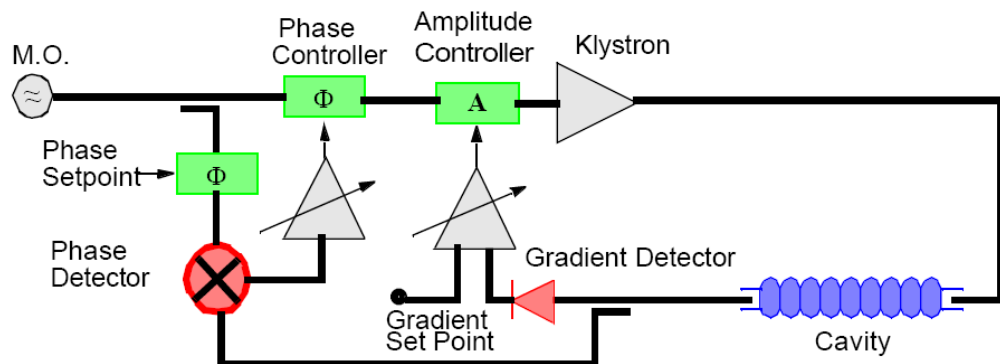

**Generator Driven Resonator**

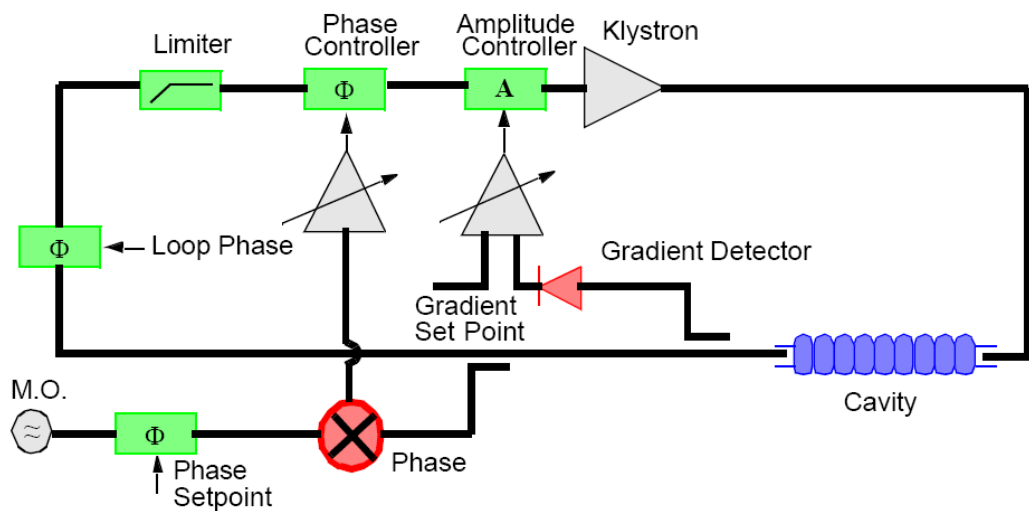

**Self Excited Loop**





# GDR Control VS SEL Control

- GDR
  - Better for pulsed operation if the detuning is small
  - Fast predictable rise time
  - Better to perform vector sum control
  - Power up can be hampered by Lorentz force detuning
- SEL
  - Tracks the resonant frequency of cavity
  - Good if the cavity resonance frequency changes over many bandwidth (~10) over turn-on
  - Possible to run many cavities at high field for conditioning of cavities and couplers independently
  - Inherently stable with amplitude
  - Unaffected by Lorentz force detuning at power up
  - Start up may be slow
  - Possible to excite other pass band and high order mode (HOM)



- Positive feedback

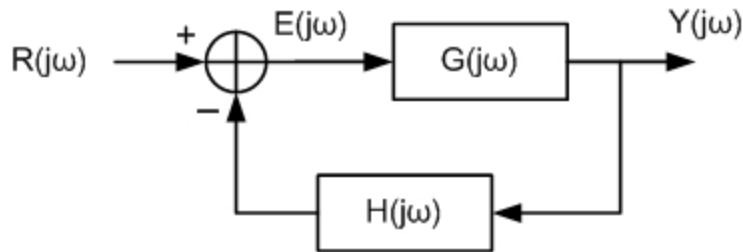

$$Y(j\omega) = \frac{G(j\omega)}{1 + G(j\omega) \cdot H(j\omega)} \cdot R(j\omega)$$

When at  $\omega_0$   $G(j\omega_0) \cdot H(j\omega_0) = -1$

The closed loop gain is infinite at  $\omega_0$ , so, even there is no input, the system has finite output - **Oscillator**

# Self Excited Loop

- Block diagram of self excited loop

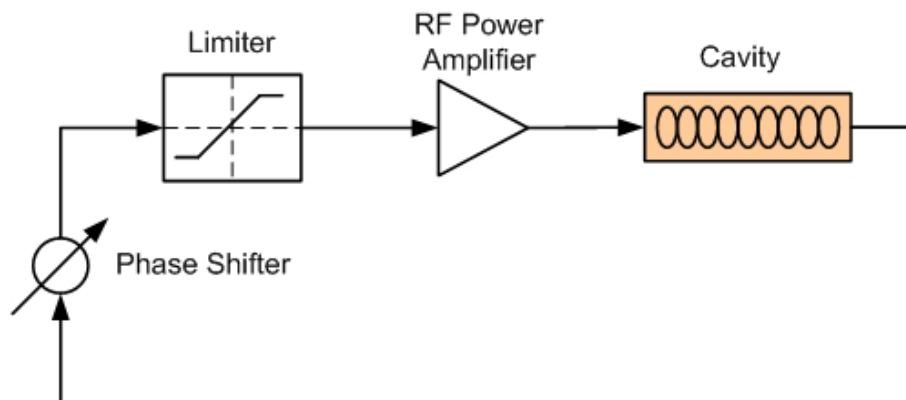

- Condition for starting up the SEL:
  - Loop gain  $> 1$
  - Loop phase  $= 2n\pi$ ,  $n=0,1,2,\dots$
- Condition for steady state of the SEL:
  - Loop gain  $= 1$  (guaranteed by the limiter)
  - Loop phase  $= 2n\pi$ ,  $n=0,1,2,\dots$

When the loop phase is changed, the working frequency will change in order to meet the phase condition for SEL

- Cavity with GDR control

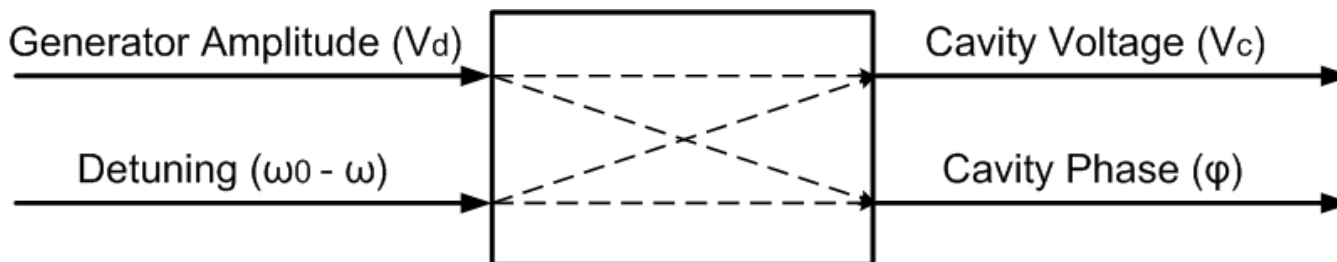

- Cavity with SEL control

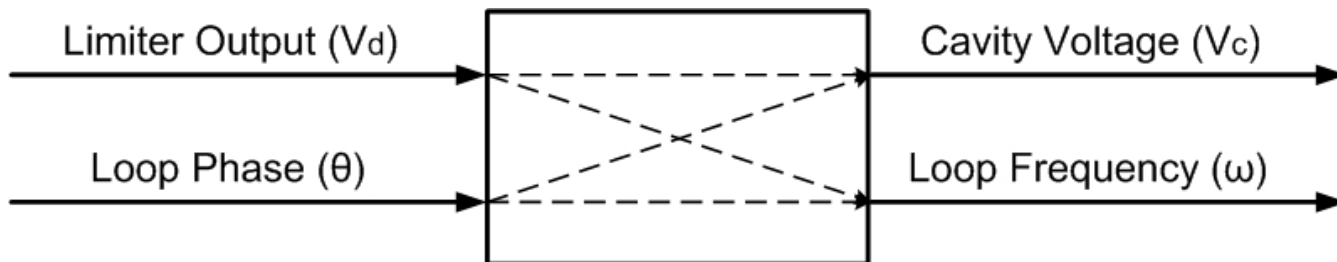



# Digital SEL Implementation at Jefferson Lab

## - Overview

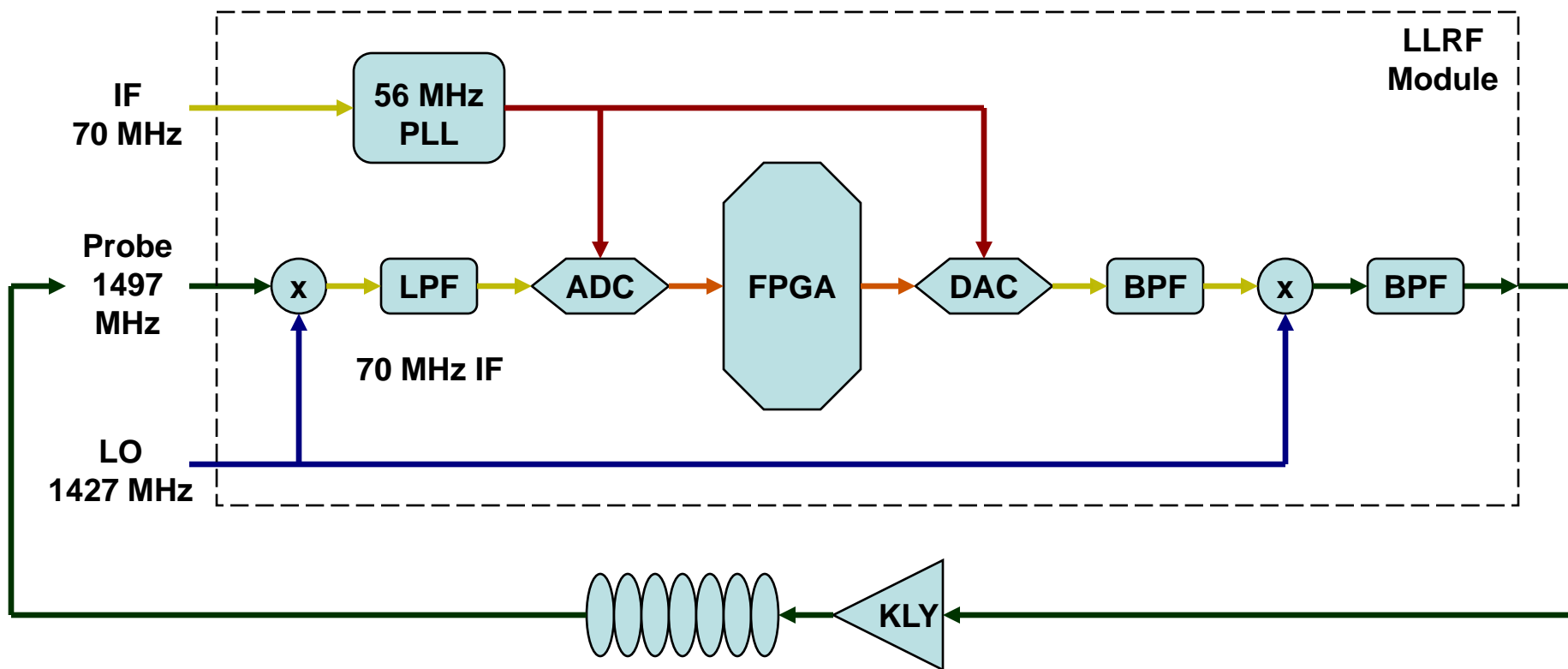



# Digital SEL Implementation at Jefferson Lab - Amplitude and Phase Control

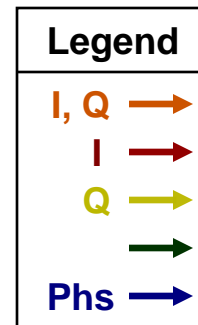
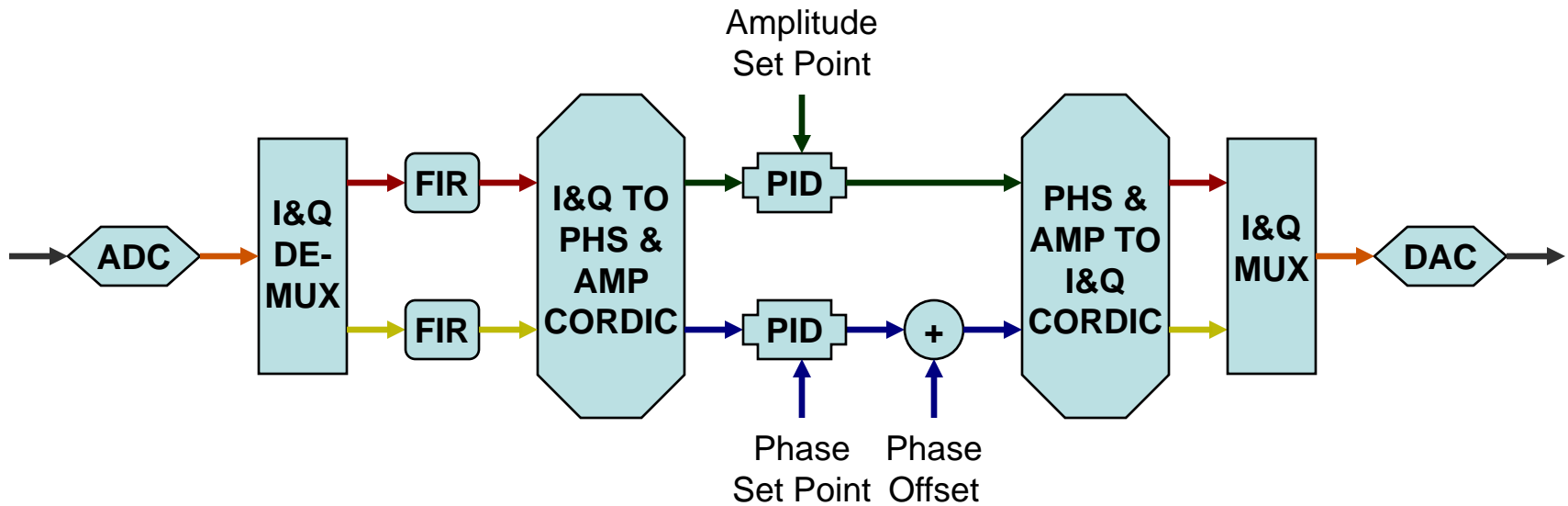

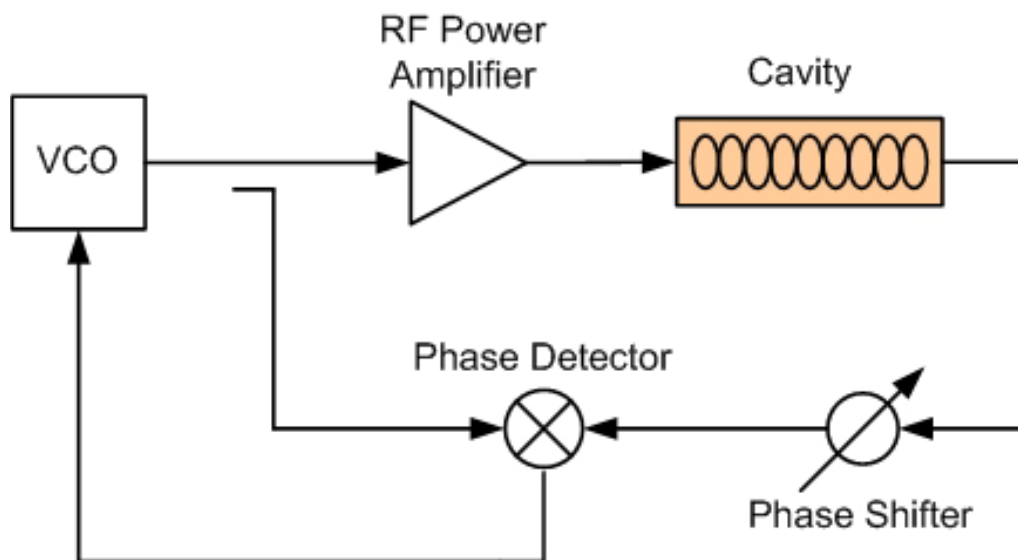

- Adjust the phase shifter to tune the working frequency
- Used for cavity testing and conditioning

# Digital PLL Control (1)

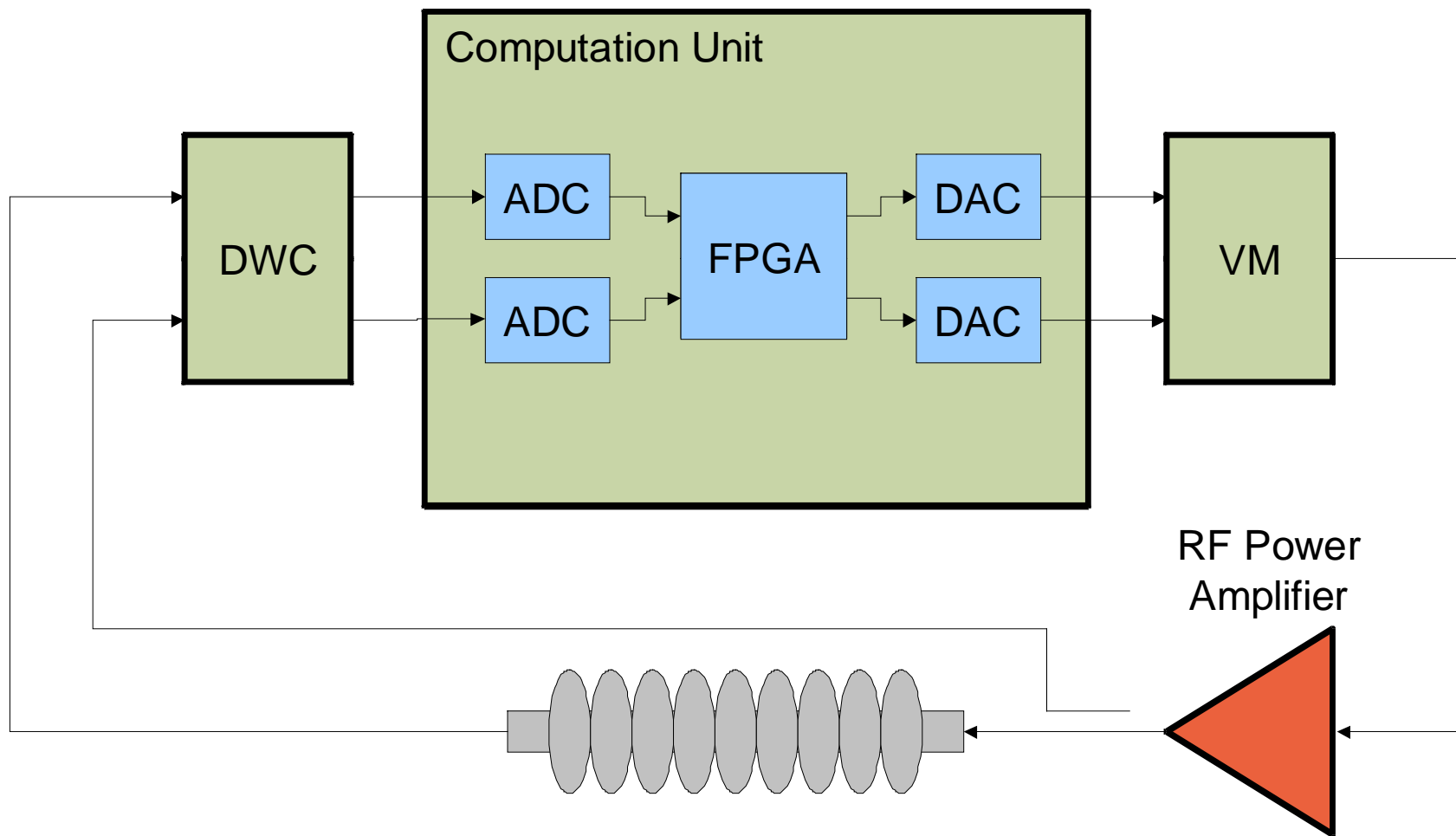

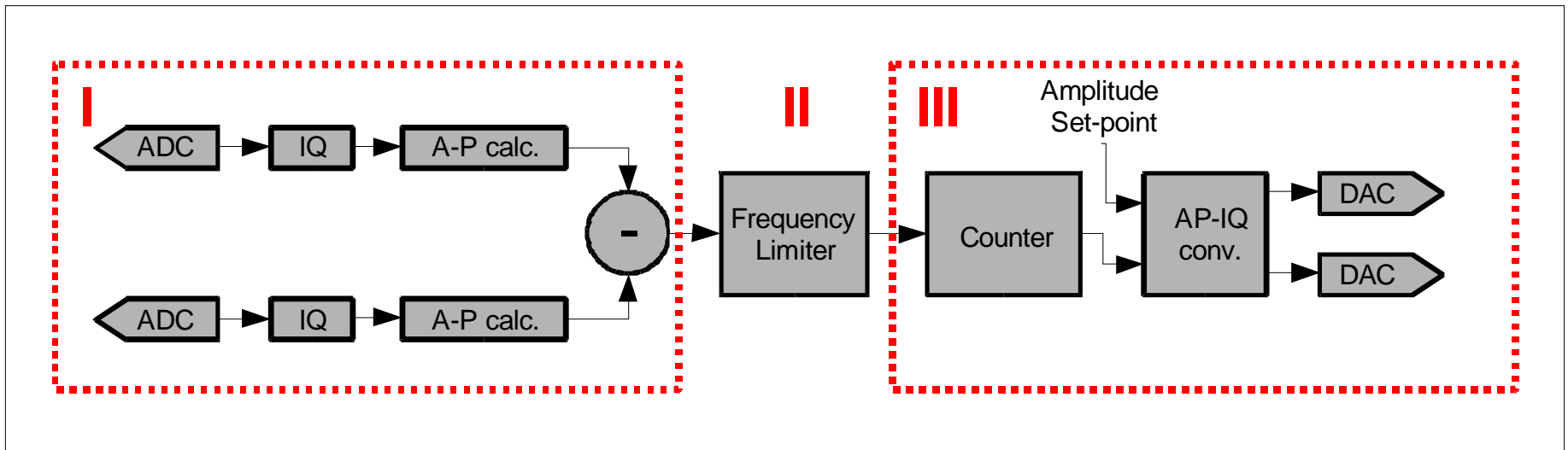

Block diagram of executed digital algorithm

- I – together with DWC forms phase detector
- II – PLL filters
- III – together with VM forms NCO/VCO



# A Concept for Universal Controller

- Build an RF field controller which contains various functionalities so that it can be adapted to different applications
- Functionalities
  - Support I/Q and A&P control or their mixture
  - Provide feedback and feed forward control
  - Provide GDR/SEL/PLL/Frequency Sweep control mode
  - Provide filters for vector sum measurement
  - Provide linearization functions to RF driving chain (klystron)

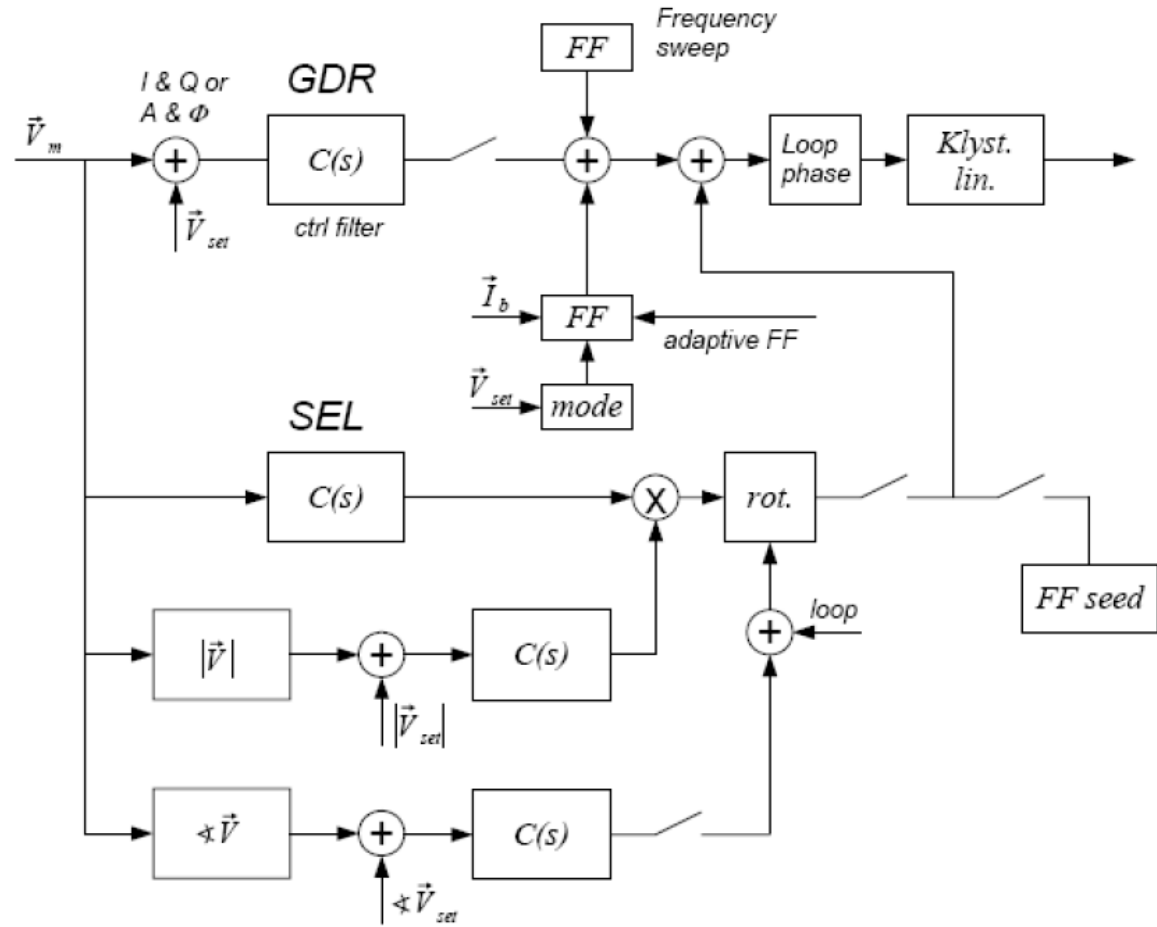
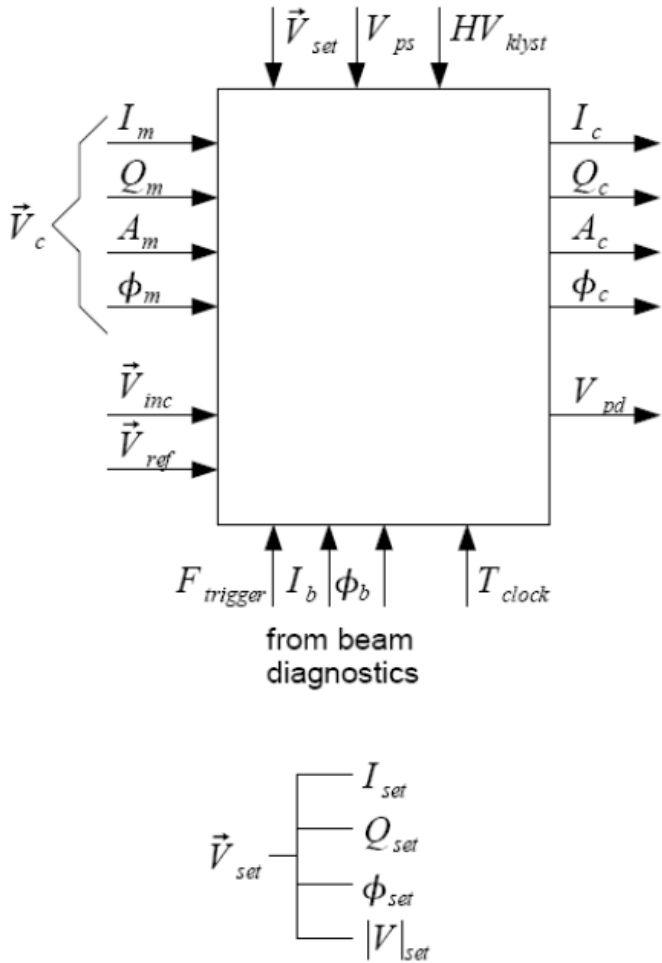

In this part, the controller for LLRF control is introduced, and several widely used control schemes are discussed and compared.

Different combination of these schemes will result in solutions for different requirements.

Finally, a concept for the universal controller is introduced.



## Reference

- [1] S.N. Simrock, “Achieving Phase and Amplitude Stability in Pulsed Superconducting Cavities”, Proceed-ings of the 2001 Particle Accelerator Conference, Chicago
- [2] J. Delayen, T. Allison, et.al. Development of A Digital Self-Excited Loop for Field Control in High-Q Superconducting Cavities. SRF2007, Peking Univ., Beijing
- [3] J.R. Delayen. Phase and Amplitude Stabilization of Superconducting Resonators. Ph.D. thesis of California Institute of Technology, 1977