

AIDA

L. Serin LAL/Orsay/IN2P3

<https://espace.cern.ch/aida/default.aspx>

- Organization & status of the project
- EUDET → LC activities in AIDA
- Conclusion

AIDA : Infrastructure for R&D in Europe

- Strong (moderate) involvement from EUDET community expected

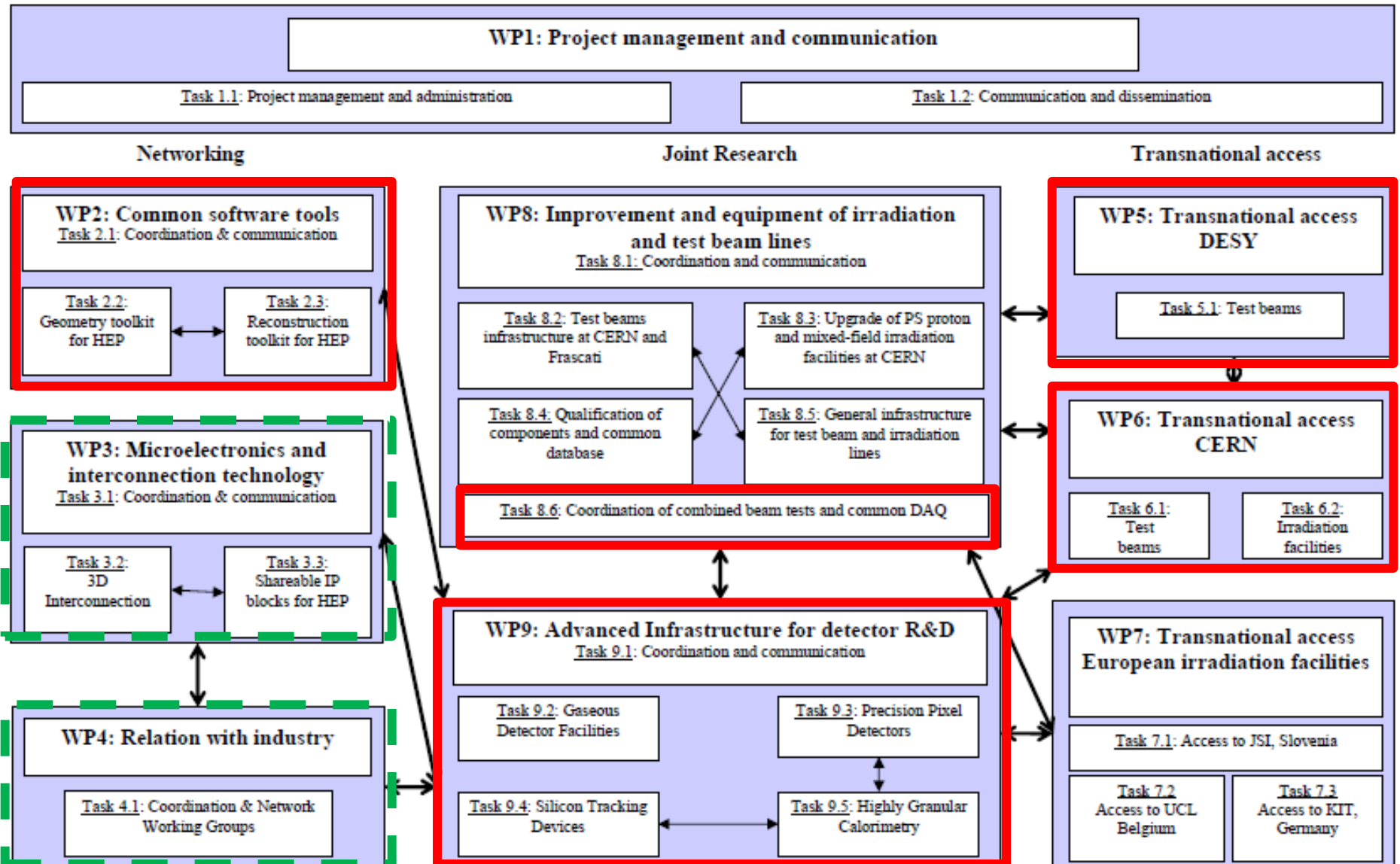

WP coordinators

- WP1 : S. Stavrev (CERN) + L. Serin (LAL/Orsay)
- WP2 : F. Gaede (DESY) + P. Mato (CERN)
- WP3 : H.G Moser (MPI) + V. Re (INFN-Pavia)
- WP4 : S. Stapnes (CERN & Oslo)
- WP5 : I. Gregor (DESY)
- WP6 : H. Breuker (CERN)
- WP7 : M. Mikuz (JSI Ljubjana)
- WP8 : M. Moll (CERN)
- WP9 : M. Vos (Valencia) + V. Boudry (LLR)

Management team

AIDA coordinator : L. Serin (LAL/ORSAY)

Deputy AIDA coordinators : T. Benke (DESY)
P. Soler (Glasgow)

Administrative coordinator : S. Stavrev (CERN)

Organisation

> 70 institutes

Chairman to be elected at kick-off meeting

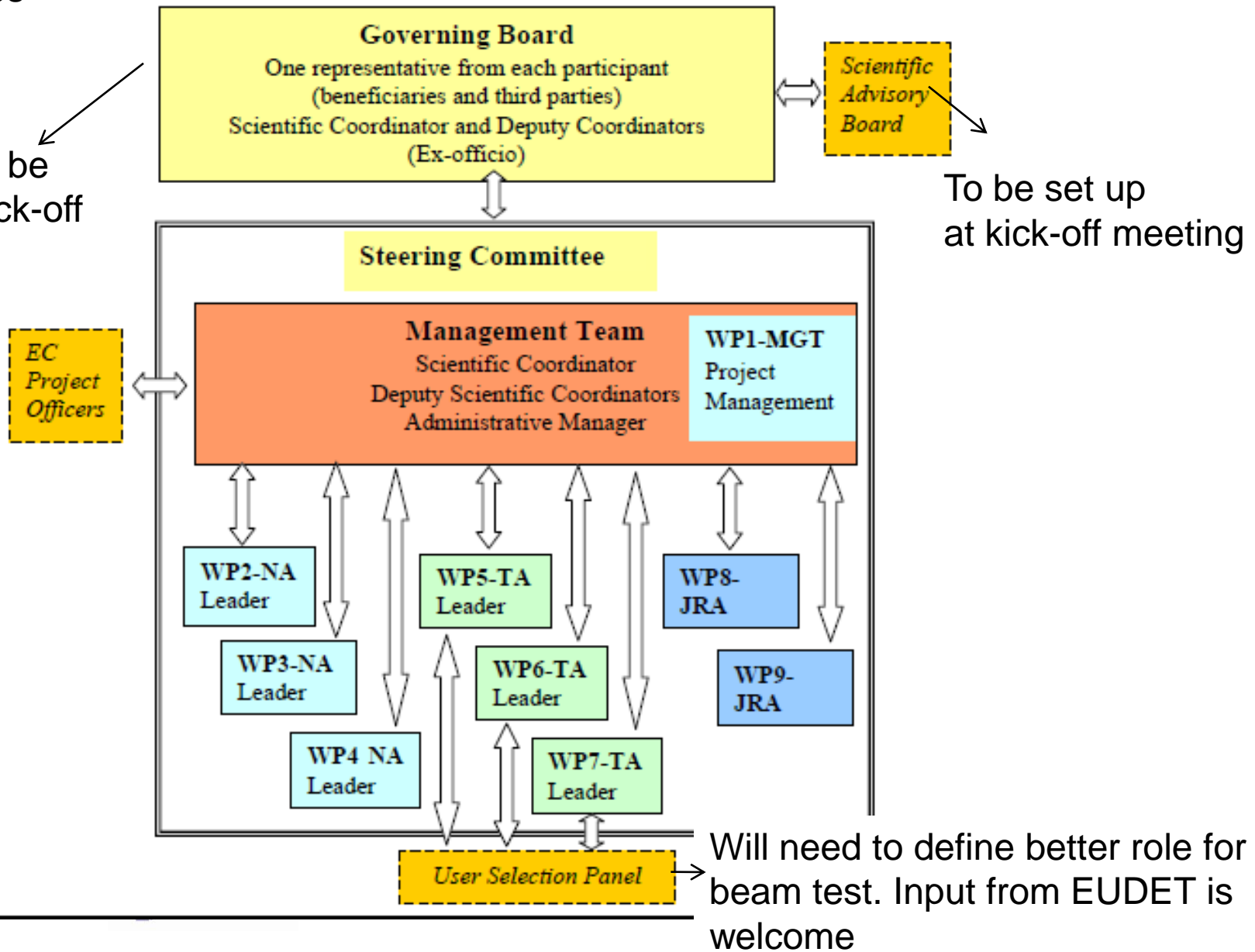

To be set up at kick-off meeting

Will need to define better role for beam test. Input from EUDET is welcome

AIDA status (1)

- Project submitted to FP7 in December 1st 2009
- Accepted for negotiation on March 26th 2010 :
Budget reduction from 10 M€ to 8 M€
Reduction of all Work-Packages according to Institute priority (especially in WP4 & WP8), remove a few tasks
Larger reduction for big contributors (CERN, DESY,...)
- All documents sent to EU end of July. Validation/checking of administrative documents is ongoing. Since then no more news but :
 - Most of the consortia used in TIARA (FP7 project in negotiation in June) have been rejected. We are expecting to face the same problems

→ Some consortia will have to be split in individual partners

AIDA beneficiaries/partners



The numbers of partners remained unchanged between proposal and negotiation (removal of Finland → associate and KIT beneficiary (Karlsruhe facility for irradiation) :

→ 32 beneficiaries representing more than 70 Institutes

If need to split some consortia, will become more than 50 beneficiaries : can be done but larger administrative overhead work for management... Might keep consortia internally in AIDA to centralize information/reports in each country

AIDA EU contribution (total budget=27M€)

Activity	Proposal	Negotiation	Reduction
WP1 : Management	450 k€	350 k€	-33 %
WP2 : Common software tools	1098 k€	906 k€	-17.5 %
WP3 : μ electronics & interconnection	1096 k€	918k€	-16.2 %
WP4 : Relation with industry	300 k€	120k€	-60 %
WP5 : DESY testbeam	100 k€	100k€	-
WP6 : CERN testbeam	150 k€	150k€	-
WP7 : European irradiation facilities	600 k€	550k€	-8.3 %
WP8: Improvement of irradiation & beam lines	3140 k€	2324k€	-25.8 %
WP9 : Advanced infrastructure for detector R&D	3066 k€	2582k€	-15.7 %

Main changes/ proposal

- WP1 : Additional free manpower from IN2P3/CNRS
- WP2 : Small reduction of scope of a few tasks on reconstruction
- WP3 : Mainly unchanged but with small increase of contribution from partners.
- WP4 : Strong reduction but still keep the WP (42 months only). Might be the starting point of a new proposal to EU. Reduce the technologies to prospect and reduce workshop to AIDA annual meeting.
- WP5 and WP6 unchanged
- WP7 : small uniform reduction
- WP8 : Main reduction from CERN priority and removal of some tasks
- WP9 : Reduction keeping the scope of the WP with larger contributions of partners

AIDA status (2)

The goal is still to start officially the project on Feb 2011
Activity/meeting of WP can start now but no fund available
before Feb 2011.

Kick-off meeting foreseen from Feb 16th to
Feb 18th 2011



AIDA status (2)

The goal is still to start officially the project on Feb 2011
Activity/meeting of WP can start now but no fund available
before Feb 2011.

Kick-off meeting foreseen from Feb 16th to
Feb 18th 2011

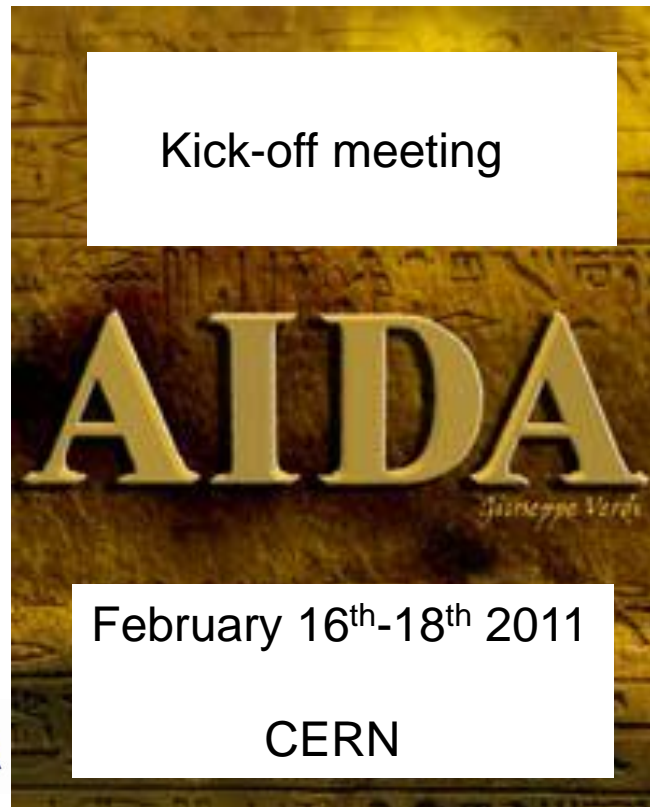

WP2 : common software tools

From F. Gaede

develop core software tools that are useful for the HEP community at large and in particular for the next big planned projects: sLHC and Linear Collider (ILC/CLIC)

Task 2.2: Geometry toolkit for HEP

- Allow the description of complex geometrical shapes, materials and sensitive detectors
- Provide interfaces to full simulation programs (Geant4), fast simulations, visualization tools and reconstruction algorithms
- Allow for the misalignment of detector components
- Provide an interface to calibration constants and conditions data

Task 2.3: Reconstruction toolkit for HEP

- Tracking toolkit based on best practice tracking and pattern recognition algorithms
- Provide alignment tools
- Allow for pile up of hadronic events
- Calorimeter reconstruction toolkit for highly granular calorimeters based on Particle Flow algorithms

general strategy:

- integrate as much as possible with existing software framework(s) and international activities outside of the AIDA project
- collaborate with software activities in other AIDA work packages, e.g. the alignment of silicon sensors

WP2 : common software tools

From F. Gaede

deliverables and milestones with contributing partners

D2.2.1	Software design for geometry toolkit including the interfaces for the reconstruction toolkits	CERN, DESY,LLR, UniGla, STFC	M12	12
D2.2.2	Software toolkit for detector geometry, materials and detection technologies		M38	
D2.3.1	Software design for tracking toolkit	DESY, OeAW, KFKI		
D2.3.2	Software design for PFA tools	Ucam, LLR, CERN,	M12	12
D2.3.3	Design for handling the pile-up in sLHC	INFN, NTU, KFKI	M18	
D2.3.4	Software toolkit with tracking algorithms	DESY, OeAW, KFKI		
D2.3.5	Particle Flow software tools	Ucam, LLR, CERN,	M38	

MS10	Running first prototype of the particle flow algorithm.	UCAM, LLR		10
MS11	Running prototype of tracking toolkit including some algorithms	DESY, OeAW		18
MS12	Running prototype of the geometry toolkit	CERN,DESY,LLR		26
MS13	Running prototype of the tracking code for the pile-up	INFN, NTU, KFKI		
MS14	Integration of tracking toolkit into LC software framework	DESY	M14	44

- first deliverables focus on software design:
 - need to properly define the (abstract) interfaces
- milestones involve integration in existing LC framework
- next steps: need to find best way to organize the collaboration among partners, e.g. regular phone meetings, occasional face to face meetings...

WP3 : μ electronics and interconnection

- Strong involvement of LHC community on 3D technology for pixel detectors but expect synergy/collaborative work with LC-pixel/CMOS activity : via last option as complementary approach to the 3D/Fermilab approach (via first) : **3D production organisation to be finalized by Feb 2012 and availability of wafers ASIC by end 2012, sensors at same period \rightarrow thinning, post processing \rightarrow interconnection test (T0+36) and assessment of 3D integrated sensors (T0+48)**
- Submission of two sets of IP macro blocks (two different technologies) **Deliverables at month T0+22 and +44:**
 - SiGe/AMS (through LAL) : IP blocks to be qualified in 0.18 μ m technology for next generation of LC calorimeter readout chips
 - IBM CMOS 0.13 μ m ? (through CERN) : some interest for tracking detectors readout

WP5 & WP6 : access to beam test

- Request from AIDA in term of allocated time is similar to what is already used by AIDA partners today.
- For 2011, would like to have an overview of all foreseen tests beam at time of kick-off meeting but continue to ask your beam through the same channel.
- **Beam test at CERN : (200 days at SPS, 50 days at PS)**
 - 2010 was overloaded,
 - Expect even larger load in 2011 (from mid April→end November). Might imagine some fine-tuning of period sharing / parasitic beam between AIDA user.
 - No beam in 2012 at CERN (*depending on LHC might be shifted to 2013*) : **one year without beam at CERN during AIDA project : more load on DESY beam test. Deliverables might need to be re-adjusted...**
- Probably possible to extend TA for a 5th year if needed
- **Beam test at DESY (40 weeks) : mid Feb→mid Dec**

WP8 : task on common DAQ

Slide from V. Boudry

Task leader: V Boudry (LLR), E. Corrin (U. Geneva)

Provide a uniform control and acquisition framework allowing for the integration of most ILC R&D components in a combined beam test

Main components are

- EUDET telescope
- CALICE prototypes
- FCAL calorimeters
- Silicon trackers
- TPC readout units

Deliverables :
T0+20 : specification documents (common interfaces/infrastructure To LC beam tests
T0+46 : Report on performance & utilisation in beam test

The integration will includes SW and HW (sync) components and the beam line Interfaces based on EUDAQ and CALICE DAQv2.

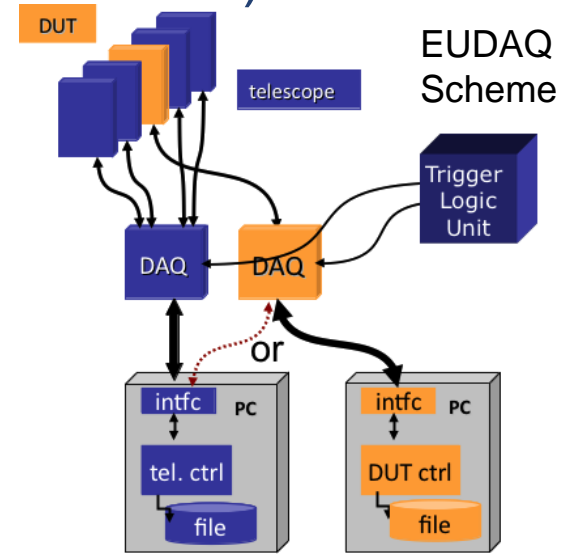

EUDAQ Trigger and Logic Unit



CALICE Scheme

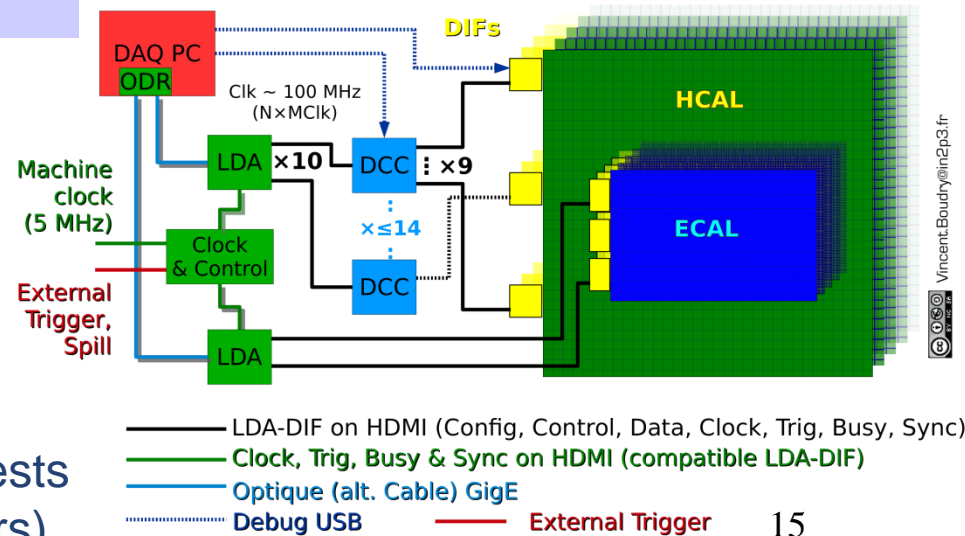

Main users: all devices needing integrated tests
 WP9.5 (set-up for High Granular Calorimeters)

WP9: Advanced infrastructure for detector R&D

Continuation of EUDET R&D naturally included in this WP
More than 50 % of the community involved here is from EUDET
but in some areas synergy with other communities expected

Four main tasks (**task leader**)

- Gaseous tracking devices : mainly LC **P. Colas (CEA)**
- Precise pixel detectors : both LHC + LC **I. Gregor (DESY) + xx**
- Strips detectors : both LC+LHC+SuperB **T Bergauer (HEPHY Vienna)**
- Granular calorimetry : exclusively LC **F. Sefkow (DESY)**

(Slides from M. Vos & V. Boudry)

WP9.2 Gaseous detectors

WP9.2 Gaseous detectors

Task leader: P. Colas (CEA Saclay)

DESY contact: K. Dehmelt

Continue the TPC infrastructure at DESY developed under EUDET: extended functionality of the end-plate, helium compressor, improve 5 T magnet (**deliverable T0+37**)

S-Altro chip (**deliverable T0+40**) ([link to WP3 ?](#))

Benefit from the CERN workshop upgrade to get access to large scale micro-pattern structures (**deliverable T0+34**)

Develop common read-out systems for gaseous detectors, enabling highly granular read-out

AIDA = EUDET++

Clients: Tracking in LC/CLIC experiments, muon chamber upgrade for LHC luminosity upgrade, MGPD for vertex detector or in granular calorimeters

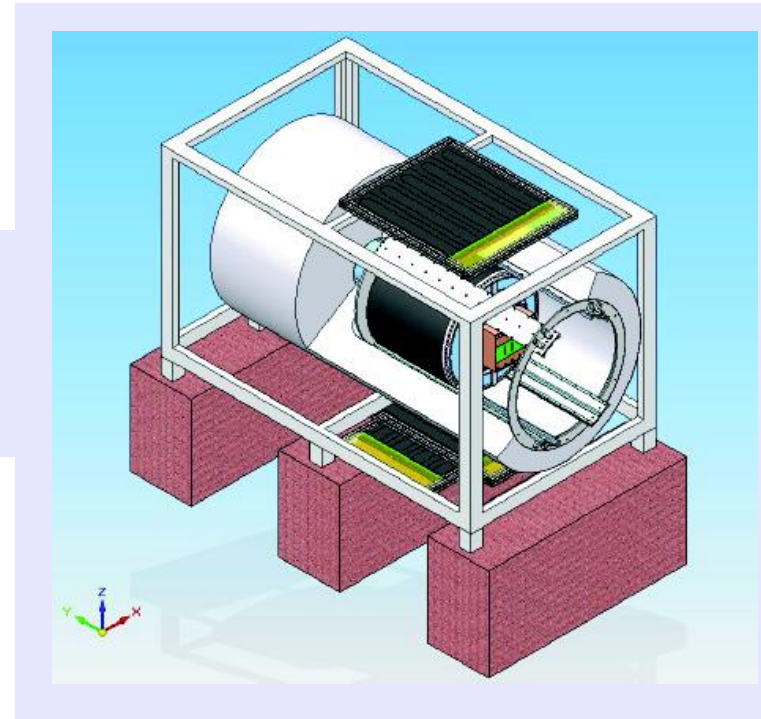

WP9.3 Precise Pixel Detectors

WP9.3 Precise Pixel Detectors

Task leader: I. Gregor (also DESY contact)

Second task leader + CERN contact to be defined

The main deliverable is an extremely precise beam telescope for characterization of prototypes (based primarily at CERN NA)

- Continuation of the EUDET telescope and surrounding infrastructure,
- Catering to sLHC needs: CO2 cooling plant, fast read-out

Deliverable : Integrated telescope arm (T0+37),

Complemented by infrastructure for high precision thermo-mechanical characterization (at DESY) (**deliverable T0+33**)

ATLAS B-layer upgrade
LHC timing

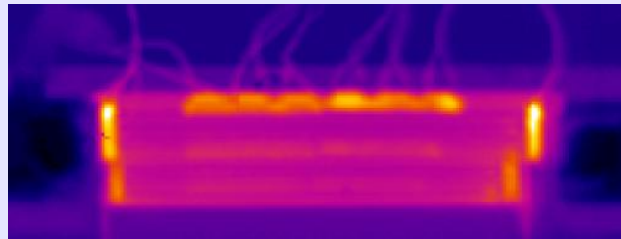
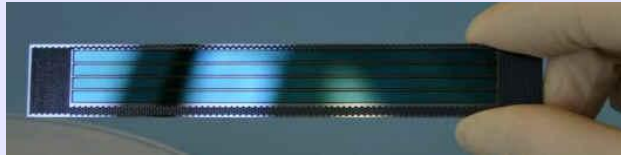
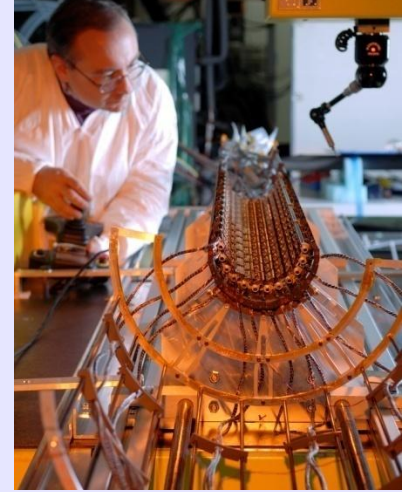

Use state of the art devices to satisfy both LC/LHC requirements

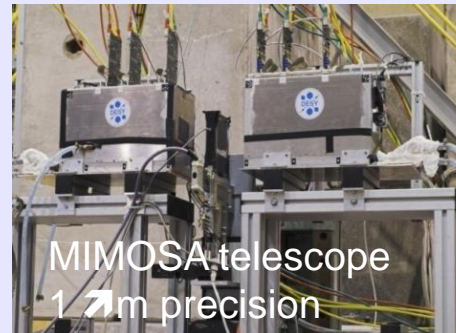

MIMOSA telescope
1 μ m precision

TimePix telescope
1 ns precision



AIDA = EUDET++

Clients: all pixel & strip detector R&D collaborations, including slice of ATLAS IBL, first full-scale Belle-II layers, 3D sensors for sLHC, prototypes from WP3, APDs, etc., etc.)

WP9.4 Silicon Tracking

WP9.4 Silicon Tracking

Task leader: Thomas Bergauer (HEPHY Vienna)

Providing multi-layer Si -strip coverage for the calorimeter stack of WP9.5

Precise entry point as a reference for study of overlapping showers

Deliverable : Si micro-strip ladders T0+39



ATLAS SCT module

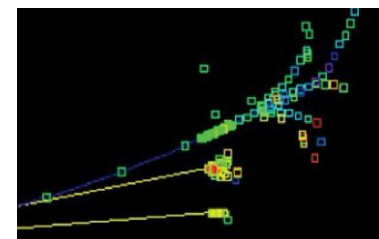
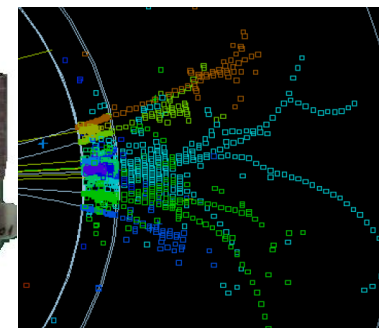

SiD simulation: 250 GeV jet and $\square \rightarrow \square + \square^0$ decay

Beneficiary short name ^a (all costs in €)	Person-Months	Personnel direct costs	Personnel indirect costs	Sub-contracting cost	Material direct costs	Travel direct costs	Material and travel indirect costs	Total direct costs	Total indirect costs	Total costs (direct + indirect)	EC requested funding
CNM	5	21,000	37,380	0	20,000	5,000	0	46,000	37,380	83,380	25,000
IFCA	24	100,800	66,528	0	0	5,000	0	105,800	66,528	172,328	53,000
IFIC	24	100,800	63,504	0	0	5,000	0	105,800	63,504	169,304	53,000
UB	18	72,000	43,200	0	0	5,000	3,000	77,000	46,200	123,200	40,000
URL	0	0	0	0	0	0	0	0	0	0	0
OEAW	28	106,400	93,632	0	0	5,000	0	111,400	93,632	205,032	62,000
CUNI	36	75,600	45,360	0	0	0	0	75,600	45,360	120,960	40,000
IPASCR	14	29,400	17,640	0	20,000	5,000	15,000	54,400	32,640	87,040	27,000
Totals:	149	506,000	367,244	0	40,000	30,000	18,000	576,000	385,244	961,244	300,000
FIXED TARGETS (MAXIMUM)										900,000	300,000
CHECKING THE CONDITION										OK	OK

Limited in funding and number of participants: modest goals and focused scope

Still a place to encourage existing collaboration on Si R&D

WP9.5 Highly Granular Calorimetry

WP9.5 Highly Granular Calorimetry

Task leader: Felix Sefkow (DESY)

Provide versatile calorimetric infrastructures to test detecting media **T0+40**

Reusing and extending the development made in EUDET to build an integrated precision set-up with pixel hodoscope, pre-calo silicon strip layers and

- an extended EM calorimeter and a hadronic radiator (Fe, W) structure
- a luminosity calorimeter structure with tungsten radiator and read-out electronics

in which many types of sensors can be tested and their response compared to simulation.

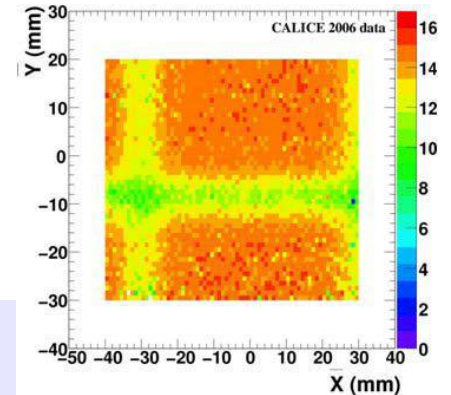

Inter-pad gap in ECAL

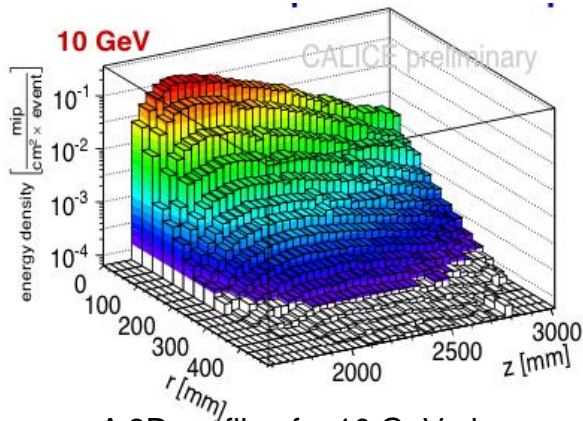

A 3D profile of a 10 GeV pion in a Fe-Scint calorimeter

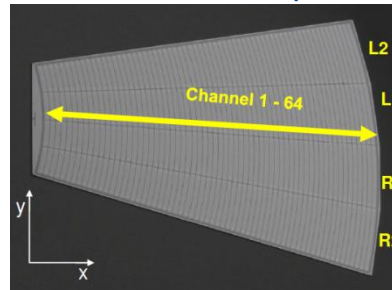

Sensor for the LumiCal

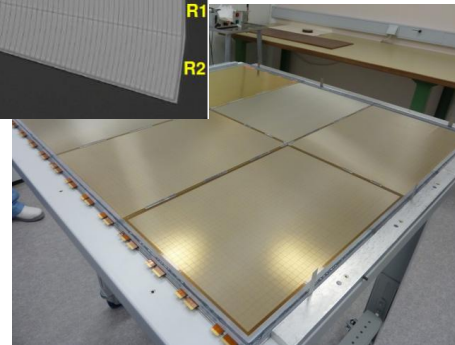

one μ -Megas m^2

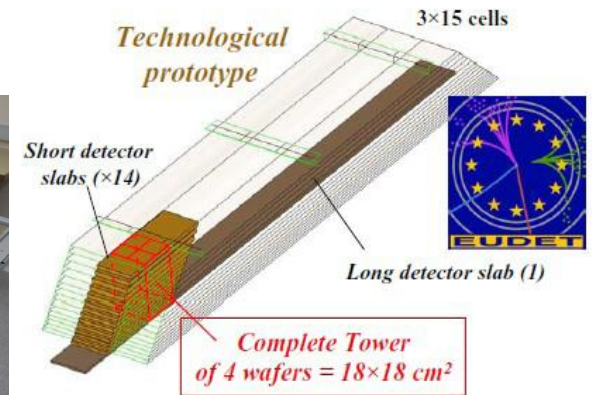

The EUDET ECAL

Large number of participants (18) in relation to WP9.2/3/4

A place to improve knowledge on the precision of highly granular calorimeters and on simulation of hadronic shower at high energy.

T0+46 : deliverable adequation of G4 simulation of hadronic shower

Conclusion

- AIDA will be the continuation of EUDET but with broader scope (not only LC activity)
- Hope to benefit from EUDET experience to consolidate the activities/groups : **Any advice is welcome.**
Any special need for continuation of EUDET activity inside AIDA.
- Expected to start in Feb 2011 (No funds available before, typically 2 M€ per year, profile sharing to be defined wrt deliverables) but some tasks expected to start (meetings) already before end 2010.