



Cavity Resonance Control

LLRF Lecture Part 4

S. Simrock, Z. Geng

ITER / SLAC



Cavity Frequency Tuner

- Motor tuner (slow), used to
 - Large range frequency tuning, such as by-pass ($\Delta\omega > 10$ times of bandwidth) the cavity or set the pre-detuning
 - Can not be tuned frequently because the motor lifetime
- Piezo tuner (fast), used to
 - Fine tuning of the cavity
 - Lorenz force detuning or microphonics compensation



Motor Tuner

The **Motor tuner** is used to tune the cavity resonance frequency by deforming the whole cavity along the axis. It uses a stepper motor and is considered as a slow control (compared with the piezo tuner).

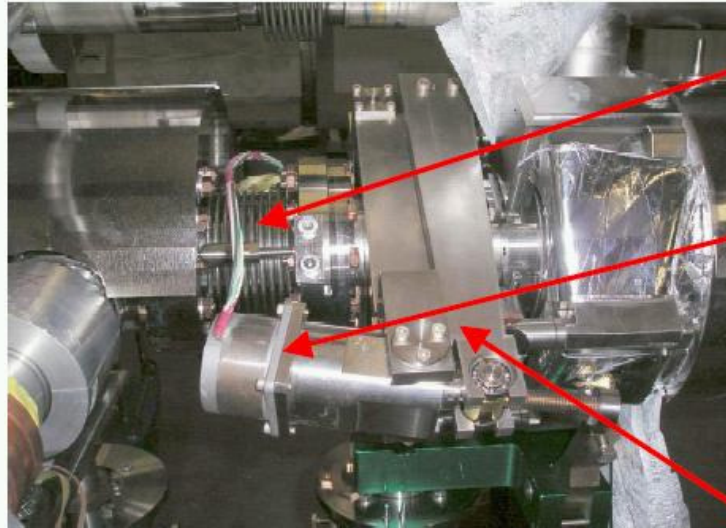

bellow connection
between nearest cavities

stepper motor

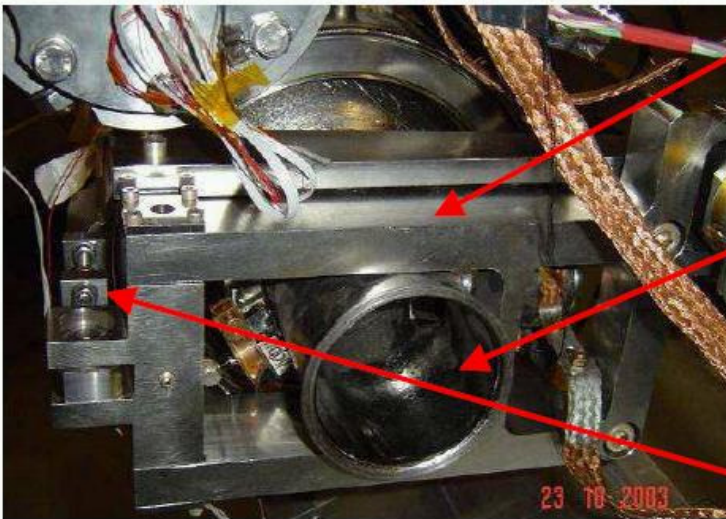

double lever mechanism

cavity flange

piezostack fixture

Piezo Tuner

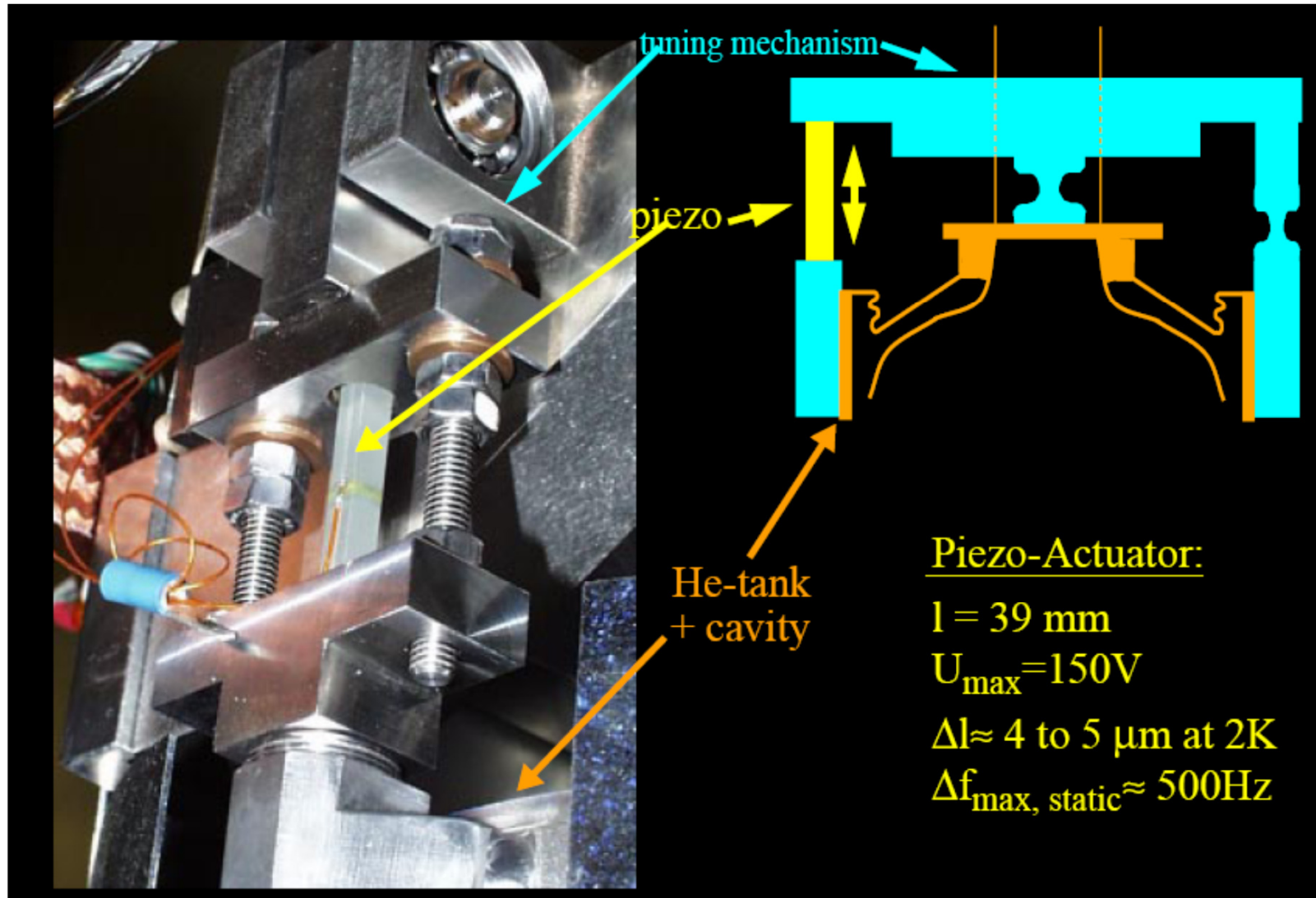



Control of Cavity Detuning

- Lorenz force detuning control
 - Feed forward control is suitable
 - Coupling of Lorenz force and piezo actuator to cavity detuning must be similar
 - Slow parameter changes can be corrected with adaptive feed forward
- Microphonics control
 - Feedback control
 - Transfer function from piezo actuator to detuning must allow controller design which allows stability of closed loop
 - Transfer function must be stable for timescale of adaptation of controller
 - Adaptive feed forward control
 - Noise cancellation with adaptive filters



Recall the Lorenz Force Detuning Model

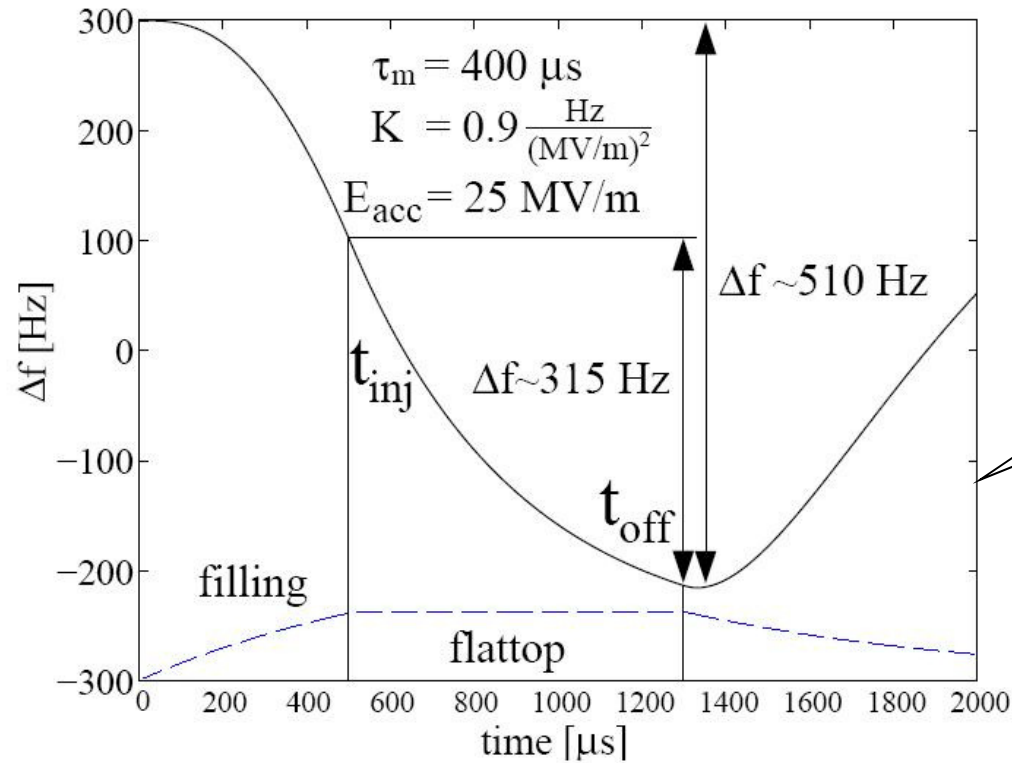

Repetitive from pulse to pulse with same gradient.



Transfer Function Lorentz Force - Detuning

Transfer function Lorentz Force --> Detuning, SNS cavity

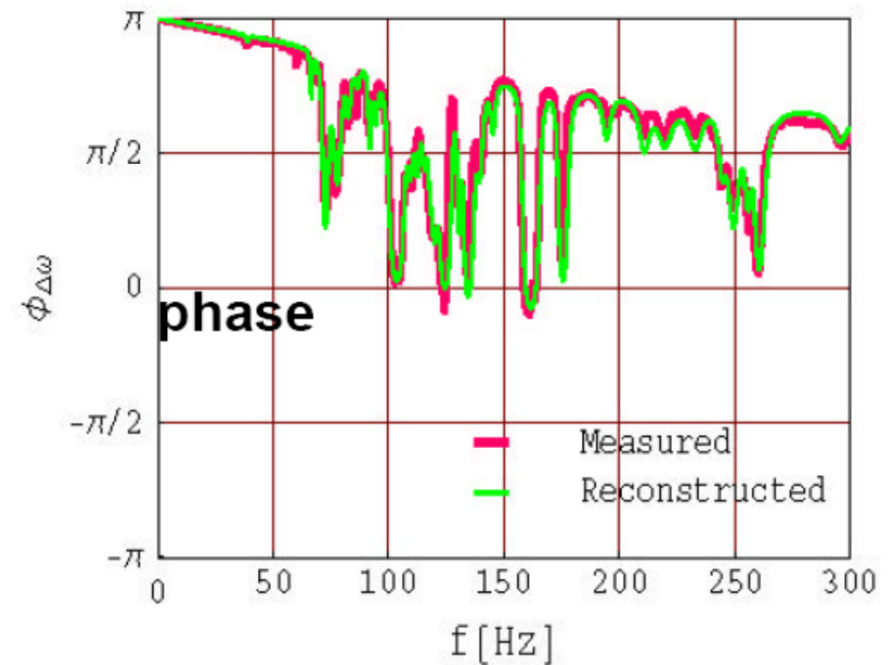
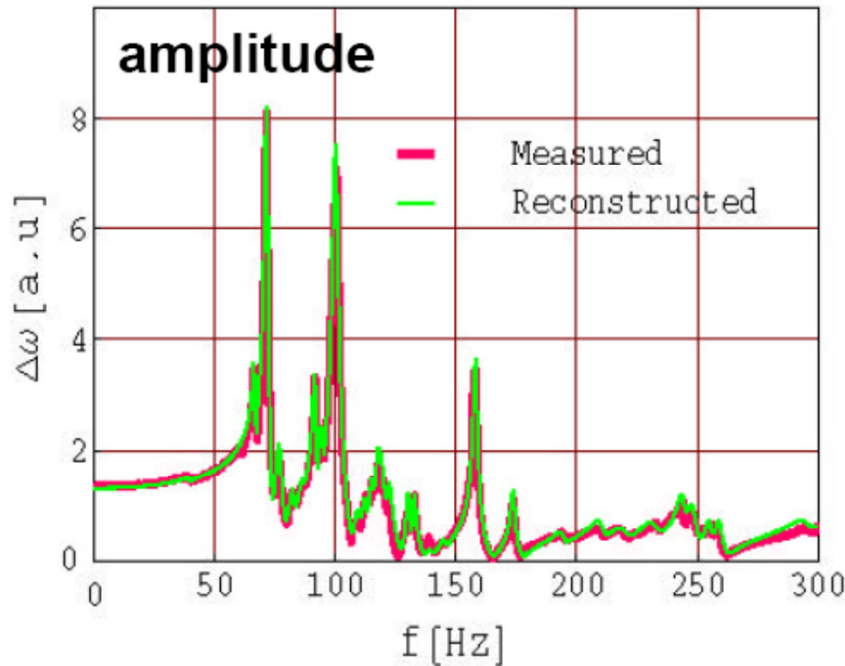

courtesy: J. Delayen, JLAB, M. Doleans, ORNL





Lorenz Force Detuning Compensation System at DESY

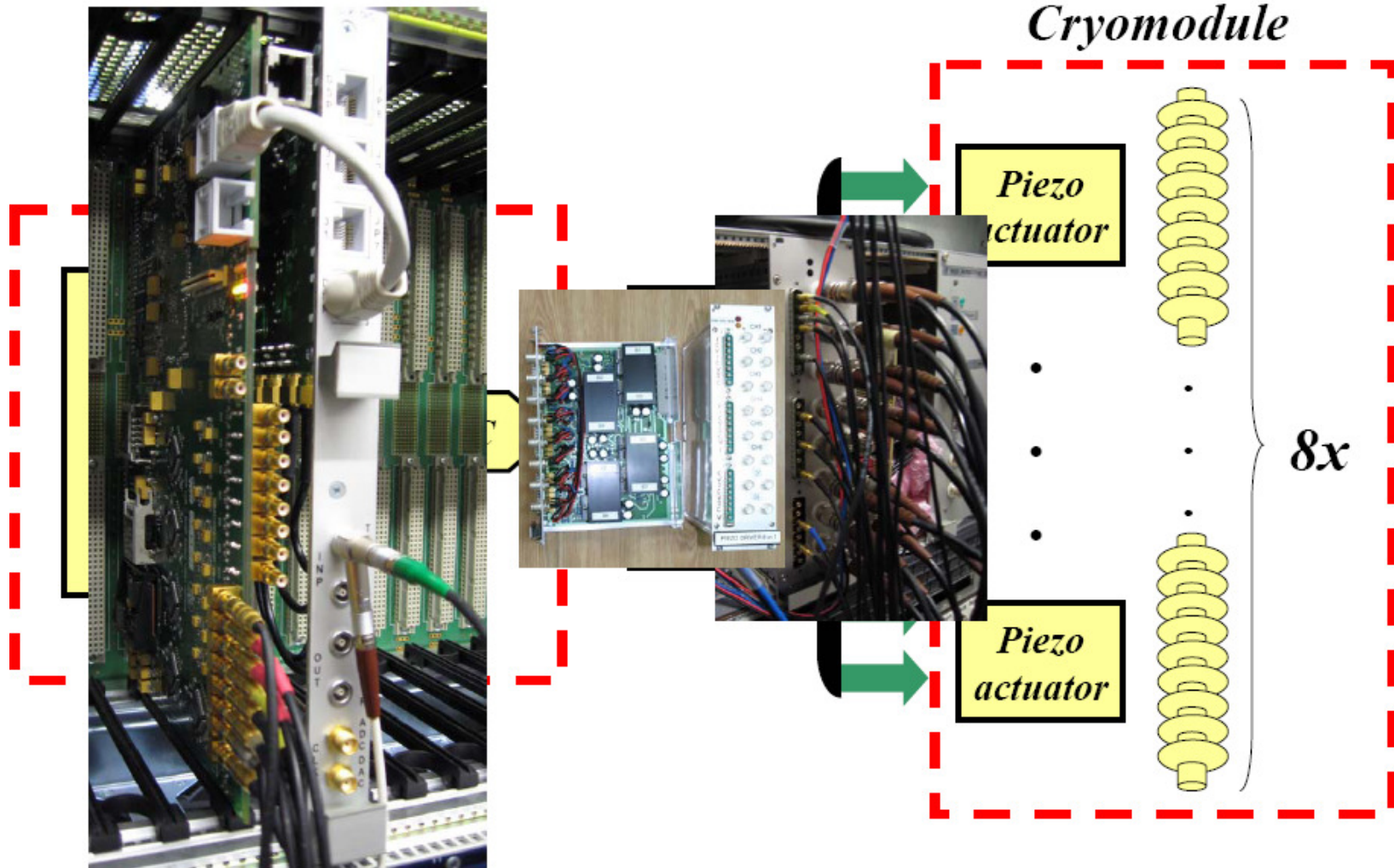



Active Compensation of Lorentz Force Detuning with Feed Forward Control

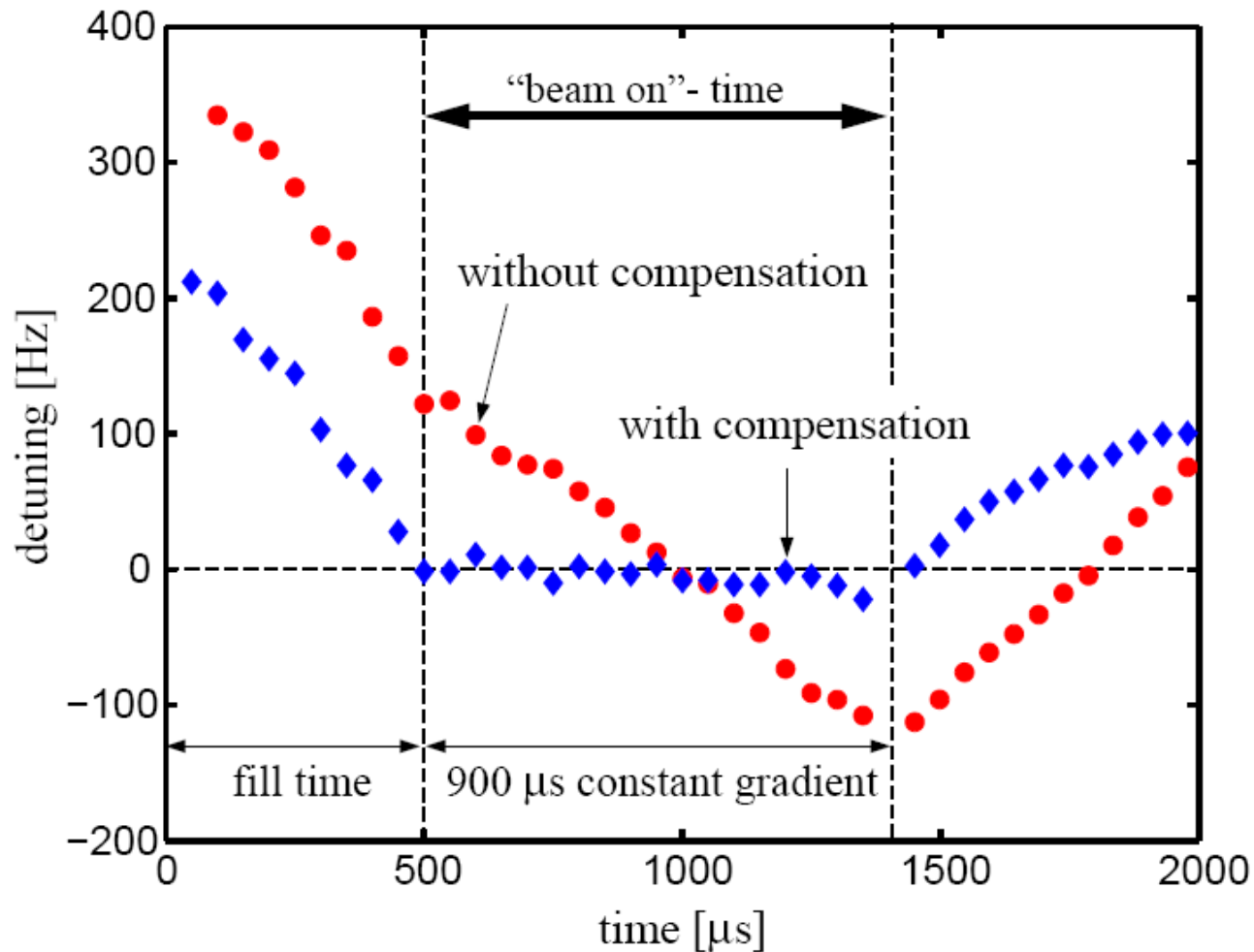

**9-cell cavity
operated at
23.5 MV/m**

**Lorentz force
compensated
with fast
piezoelectric
tuner**



More Results at ACC6 of FLASH

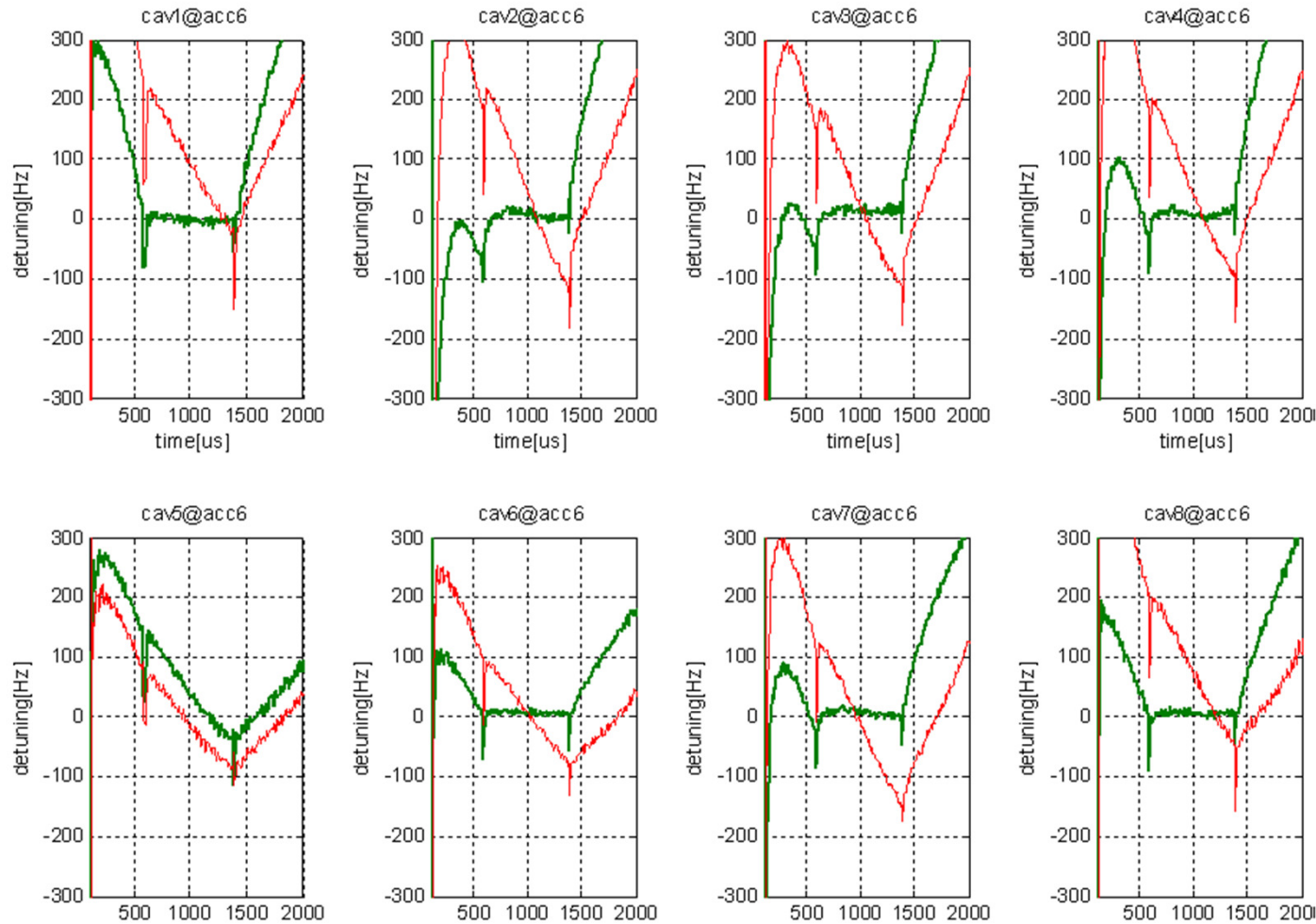

Problem with tuner assembling



Concept for Controlling Microphonics with Feedback

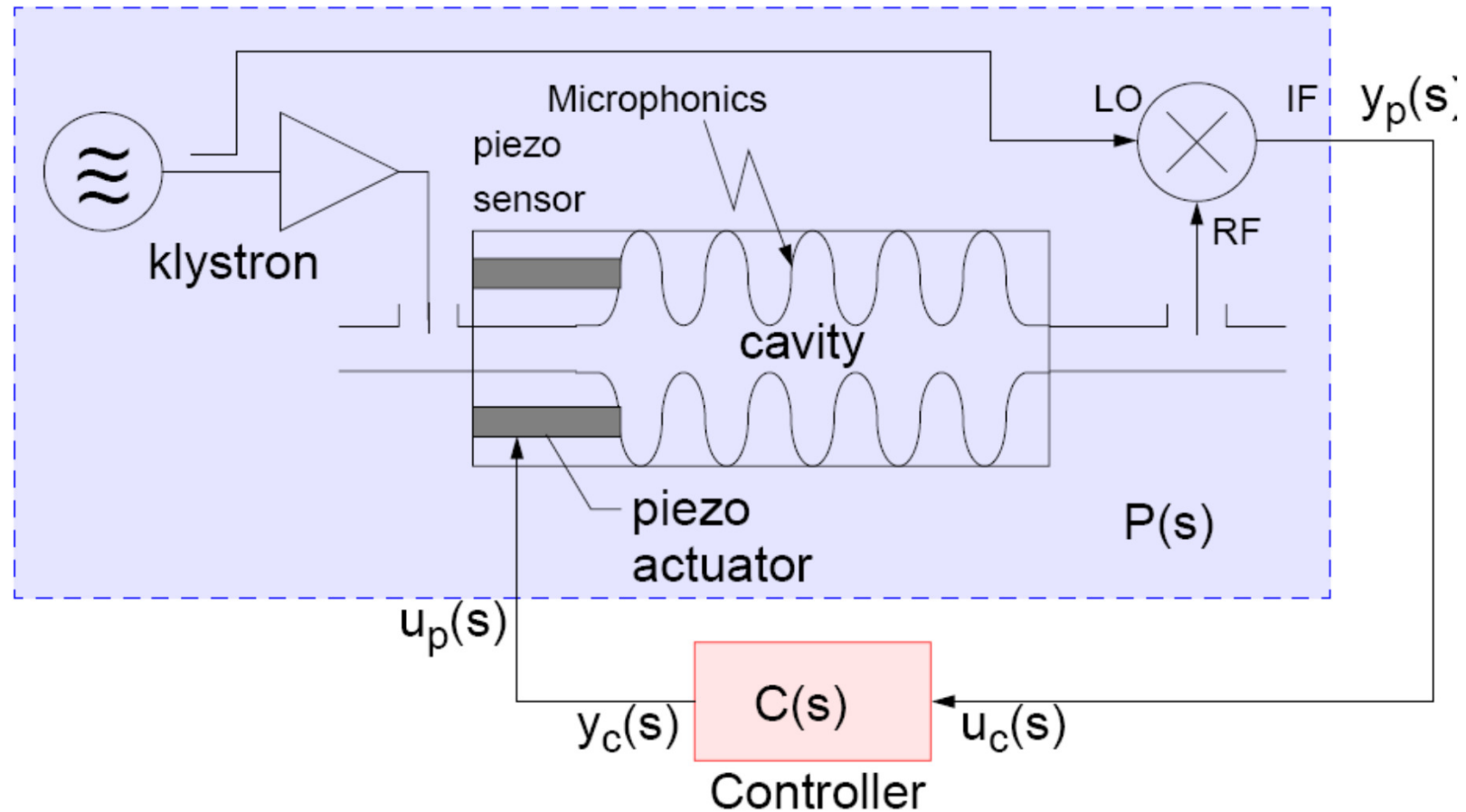



Microphonics Control of a Quarter Wave Cavity

- Feedback is stable up to several hundred Hz, because the vibrations from the microphonics have a low frequency, while the resonance peaks in the piezo tuner transfer function locate at higher frequency

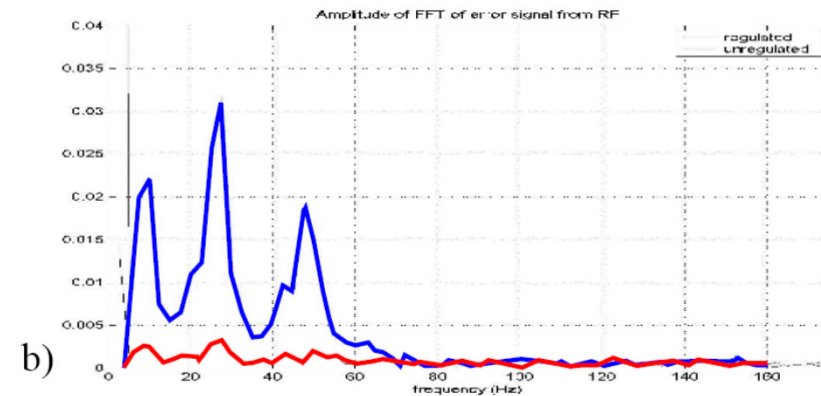
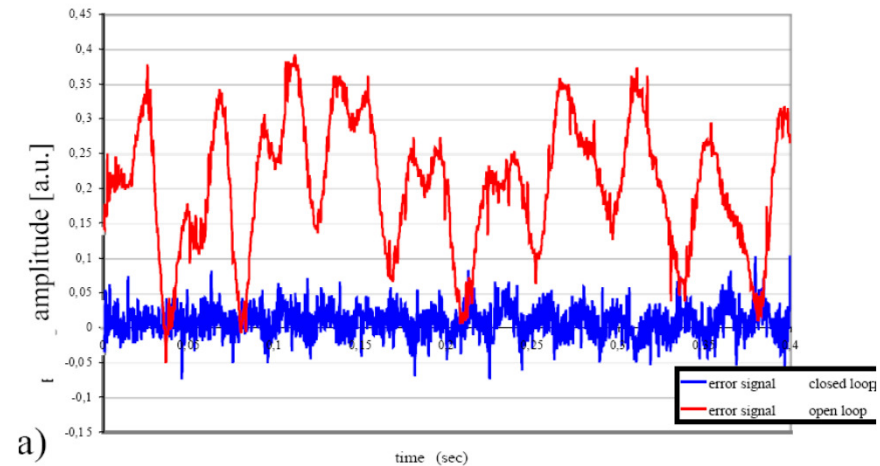

Active suppression of microphonic noise with feedback applied to fast piezo tuner. a) Time domain measurement. b) Frequency domain measurement



Transfer Function Piezo - Detuning

Transfer function Piezo Tuner --> Detuning, SNS cavity

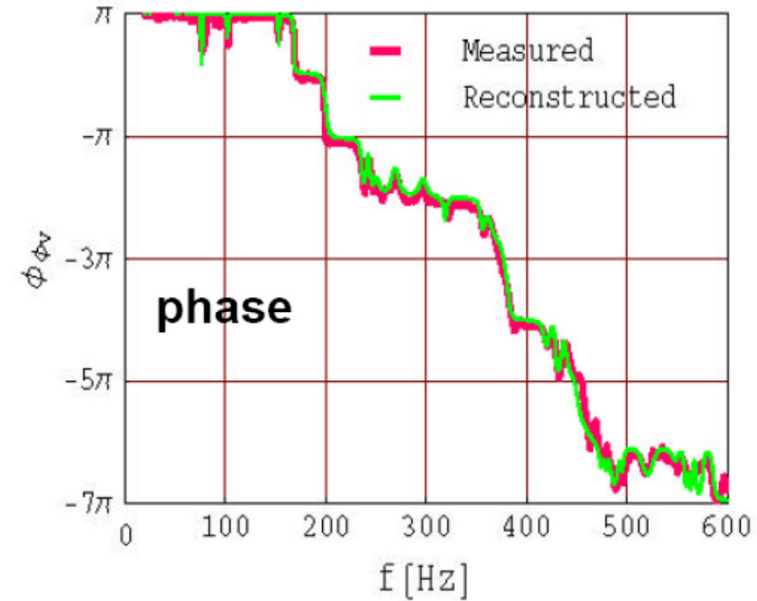
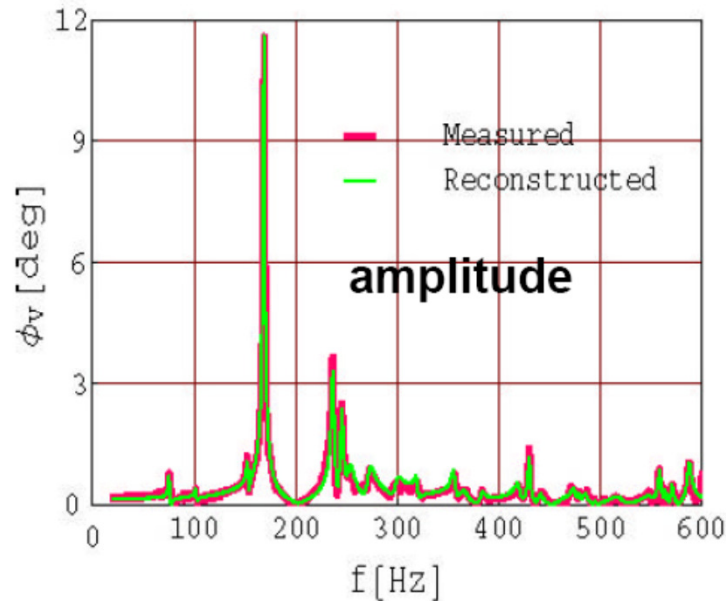

courtesy: J. Delayen, JLAB, M. Doleans, ORNL



- For multi-cell cavities like SNS cavity and TESLA cavity, feedback system for microphonics control is unstable because the many resonance peaks at low frequency which dramatically decrease the gain margin!



Concept for Controlling Microphonics with Adaptive Feed Forward

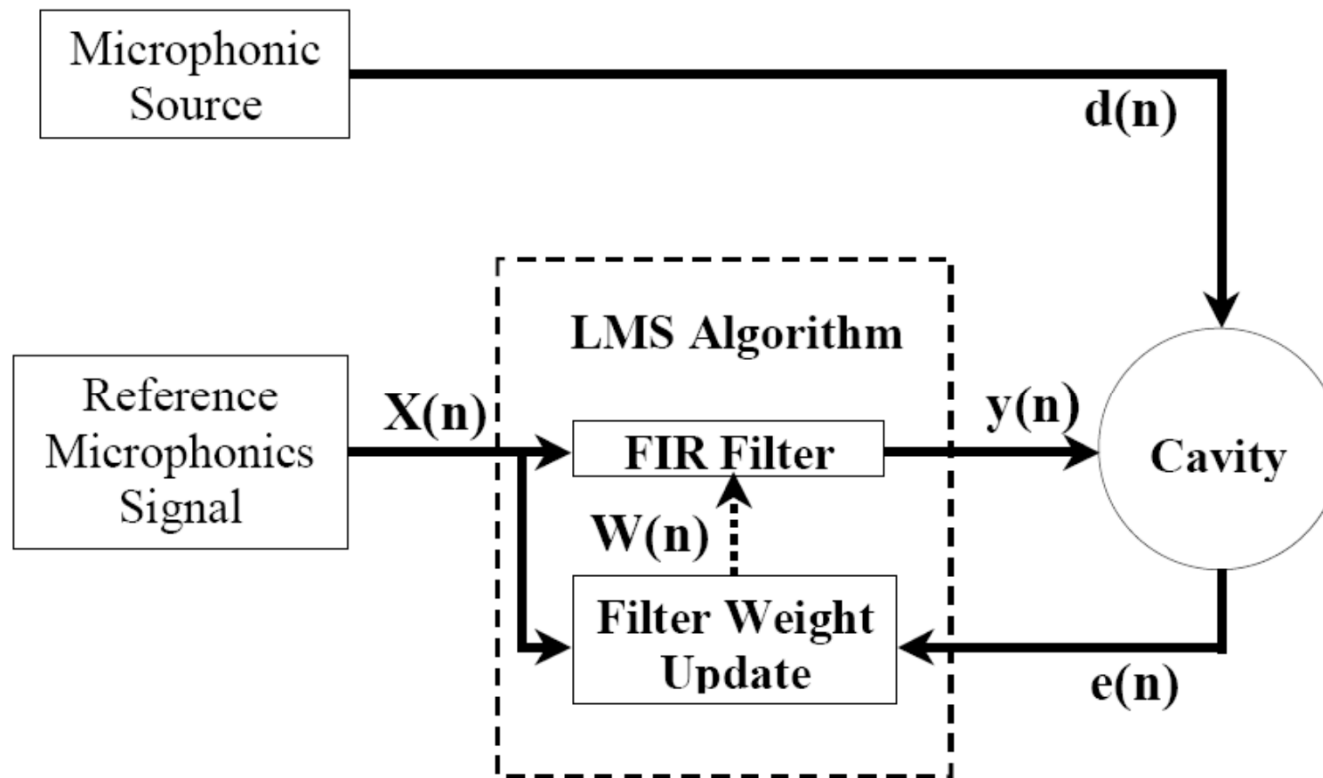



Piezo Control of Microphonics with Adaptive Feed Forward in JLAB

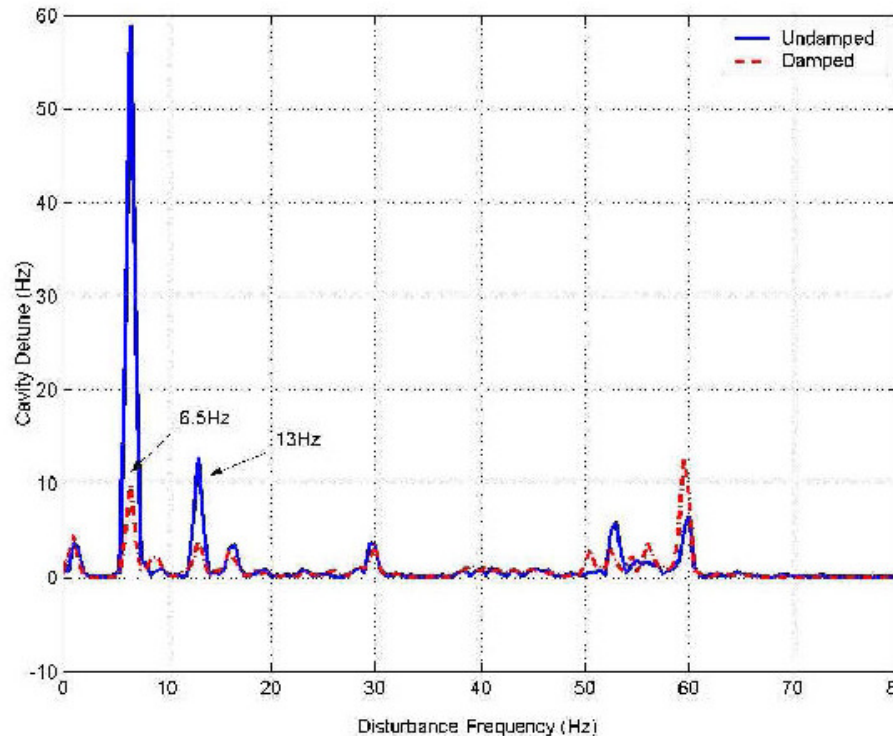

Active damping of helium oscillations at 2K.

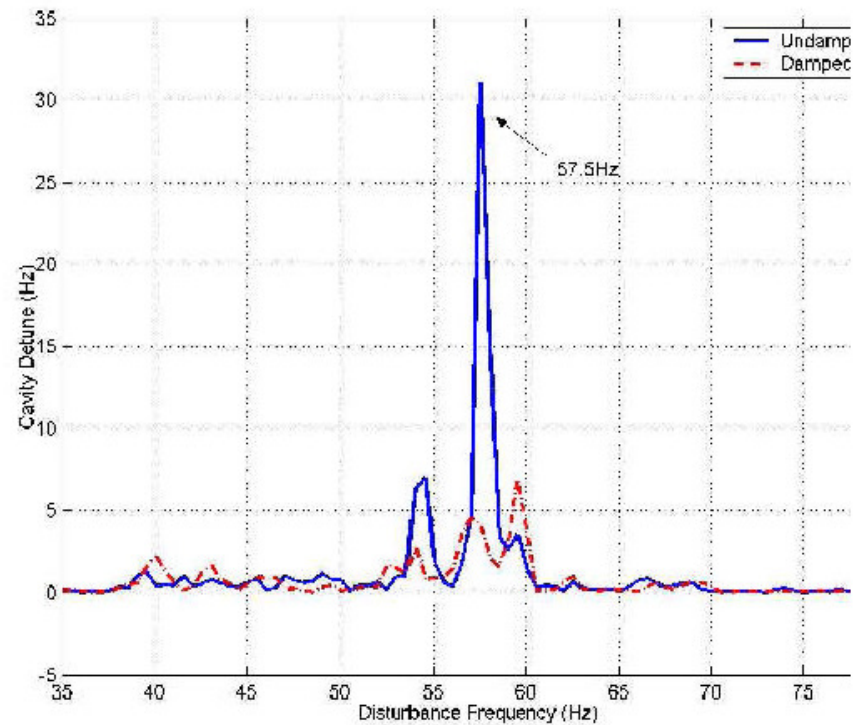

Active damping of external vibration at 2K.

T. Grimm



Piezo Control of Microphonics with Adaptive Feed Forward in Fermilab

FNAL, 3-cell 3.9 GHz

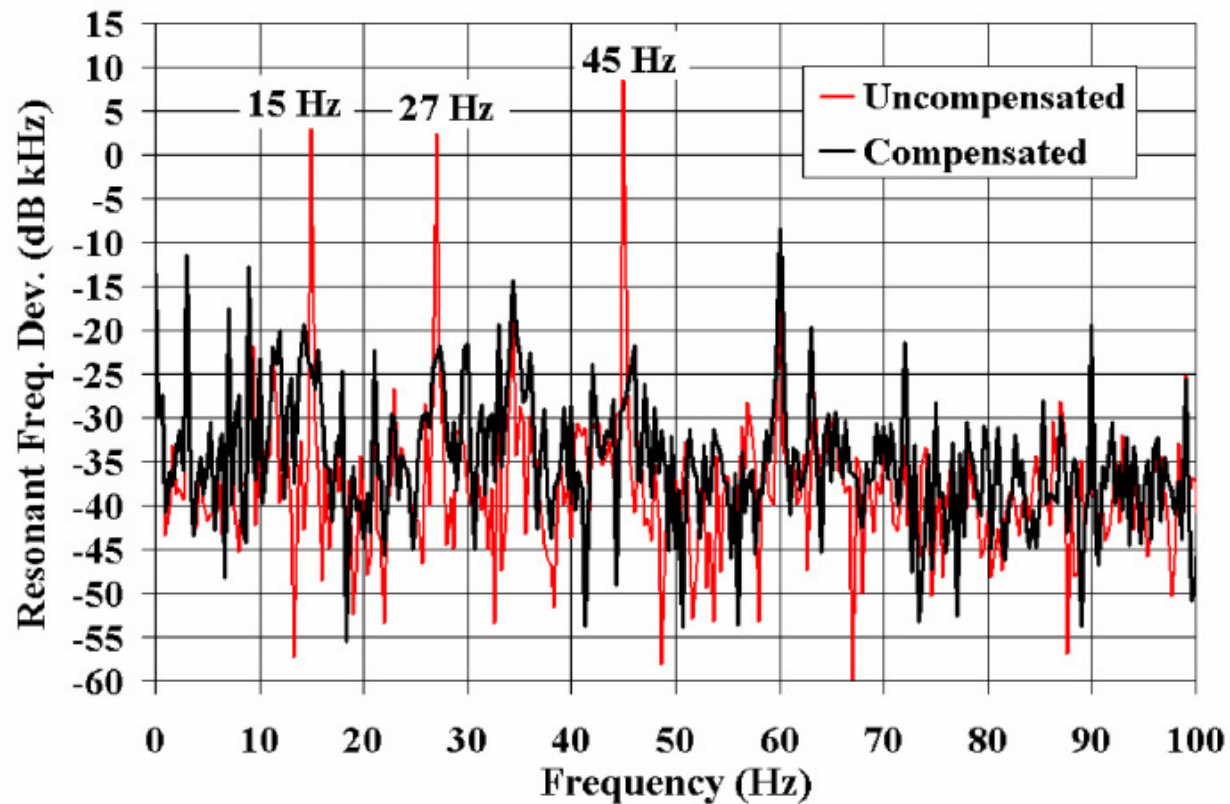



Summary

In this part, we have learnt:

- Motor tuner and piezo tuner can be used to control the cavity resonance frequency
- Lorenz force detuning can be controlled with (adaptive) feed forward control
- Feedback can be used to control the microphonics for some special cavities, but does not work well for multi-cell cavities like the SNS or TESLA cavity
- Adaptive noise cancellation can be used to control the microphonics



Reference

- [1] P. Sekalski, S. Simrock, et.al. Lorenz Force Detuning Compensation System for Accelerating Field Gradient Up to 35 MV/m for Superconducting XFEL and TESLA Nine-Cell Cavities. CARE-Conf-04-001-SRF
- [2] S. Simrock, G. Petrosyan, et.al. First Demonstration of Microphonic Control of A Superconducting Cavity with A Fast Piezoelectric Tuner. PAC2003
- [3] R. Carcagno, L. Bellantoni, et.al. Microphonics Detuning Compensation in 3.9 GHz Superconducting RF Cavities. SRF2003