

# Detector Hall

Tom Lackowski

# Revised Nomenclature

## e- MAIN LINAC

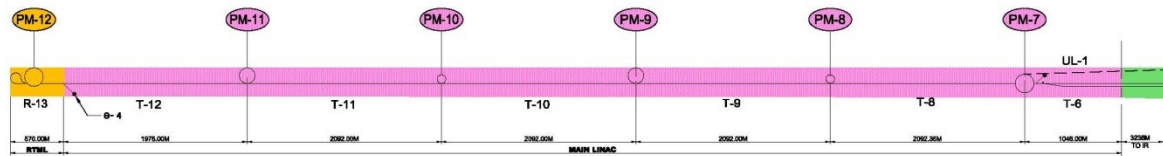

1. e- MAIN LINAC LENGTH DOES NOT ACCOUNT FOR UNDULATOR ENERGY LOSS.
2. MAIN LINAC LENGTH DOES NOT INCLUDE OVERHEAD.
3. CAVERN DIMENSIONS ARE BASED ON THE AMERICAS GEOLOGIC CONDITIONS.

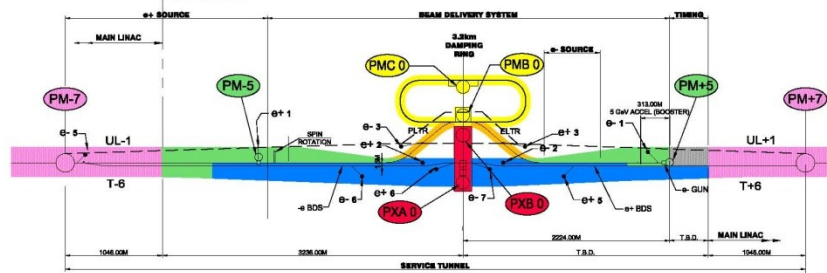

- LEGEND**  
INDICATES SHAFTS FOR KLYCLUSTER TECHNOLOGY ONLY
- RTML
  - ML
  - SOURCES
  - DR
  - BDS
  - DETECTOR AREA
  - TIMING

## e+ MAIN LINAC

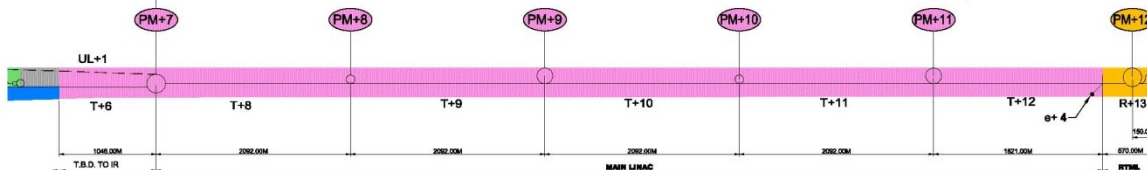

SHAFTS AND CAVERNS	PM-12	PM-11	PM-10	PM-9	PM-8	PM-7	PM-6	PM-5	PM-4	PM-3	PM-2	PM-1	PM-0	PM-0	PM-1	PM-2	PM-3	PM-4	PM-5	PM-6	PM-7	PM-8	PM-9	PM-10	PM-11	PM-12	
NAME	PM-12	PM-11	PM-10	PM-9	PM-8	PM-7	PM-6	PM-5	PM-4	PM-3	PM-2	PM-1	PM-0	PM-0	PM-1	PM-2	PM-3	PM-4	PM-5	PM-6	PM-7	PM-8	PM-9	PM-10	PM-11	PM-12	
CAVERN (LxWxH) m	120x25x38	4x4x8 SHMPT	4x4x8 SHMPT	52x10x6.5	52x10x6.5	52x10x6.5	52x10x6.5	52x10x6.5	52x10x6.5	52x10x6.5	52x10x6.5	52x10x6.5	52x10x6.5	52x10x6.5	52x10x6.5	52x10x6.5	52x10x6.5	52x10x6.5	52x10x6.5	52x10x6.5	52x10x6.5	52x10x6.5	52x10x6.5	52x10x6.5	52x10x6.5	52x10x6.5	52x10x6.5

TUNNELS WIDTH (M)	e- INJECT	DR	RTML	MAIN LINAC	e+ INJECT
AREA SYSTEM	4.5 + 4.5	5.0	4.5	4.5 + 4.5	4.5 + 4.5
AMERICA-WIDE M	-	-	-	5.2	-
EUROPE-WIDE M	-	-	-	5.2	-
ASIA-WIDE M	-	-	-	5.2	-

- ⊖ 1 NC TUNE UP DUMP 11KW
- ⊖ 2 SC TUNE UP DUMP 311KW
- ⊖ 3 DRXK TUNE UP DUMP 311 KW
- ⊖ 4 RTML TUN EUP DUMP 220 KW
- ⊖ 5 e- LINAC FAST ABORT 11 KW
- ⊖ 6 BDS TUNE UP DUMP 18MW
- ⊖ 7 PRIMARY e- DUMP - 20MW
- ⊕ 1 TARGET DUMP 200 KW
- ⊕ 2 SC TONE UP DUMP 311 KW
- ⊕ 3 PORX TUNE UP DUMP 311 KW
- ⊕ 4 RTML TUNE UP DUMP 220 KW
- ⊕ 5 BDS TUNE UP DUMP 18MW
- ⊕ 6 PRIMARY e+ DUMP - 20 MW

DETECTORS HALL	POINT	MUON WALL WIDTHS
(L x W x H) m	120 x 25 x 39	POINT
		⊖ 5, ⊖ 6
		⊕ 5, ⊕ 6, ⊕ 7
		(L x W x H) m
		25 x 7 x 8
		115 x 12 x 8

BEAM ABORT CAVERNS ( # )	SOURCES	ML	BDS
POINT	e-1, e-2, e-3, e-4, e-5, e-6, e-7, e-8, e-9, e-10, e-11, e-12, e-13, e-14, e-15, e-16, e-17, e-18, e-19, e-20, e-21, e-22, e-23, e-24, e-25, e-26, e-27, e-28, e-29, e-30, e-31, e-32, e-33, e-34, e-35, e-36, e-37, e-38, e-39, e-40, e-41, e-42, e-43, e-44, e-45, e-46, e-47, e-48, e-49, e-50, e-51, e-52, e-53, e-54, e-55, e-56, e-57, e-58, e-59, e-60, e-61, e-62, e-63, e-64, e-65, e-66, e-67, e-68, e-69, e-70, e-71, e-72, e-73, e-74, e-75, e-76, e-77, e-78, e-79, e-80, e-81, e-82, e-83, e-84, e-85, e-86, e-87, e-88, e-89, e-90, e-91, e-92, e-93, e-94, e-95, e-96, e-97, e-98, e-99, e-100	e-5, e-15	e-5, e-6, e-7, e-8, e-9, e-10, e-11, e-12, e-13, e-14, e-15, e-16, e-17, e-18, e-19, e-20, e-21, e-22, e-23, e-24, e-25, e-26, e-27, e-28, e-29, e-30, e-31, e-32, e-33, e-34, e-35, e-36, e-37, e-38, e-39, e-40, e-41, e-42, e-43, e-44, e-45, e-46, e-47, e-48, e-49, e-50, e-51, e-52, e-53, e-54, e-55, e-56, e-57, e-58, e-59, e-60, e-61, e-62, e-63, e-64, e-65, e-66, e-67, e-68, e-69, e-70, e-71, e-72, e-73, e-74, e-75, e-76, e-77, e-78, e-79, e-80, e-81, e-82, e-83, e-84, e-85, e-86, e-87, e-88, e-89, e-90, e-91, e-92, e-93, e-94, e-95, e-96, e-97, e-98, e-99, e-100
(L x W x H) m	10 x 13 x 7	20 x 9 x 15	20 x 4 x 8

**SHEET - 1**  
**Draft**  
**05-12-11**

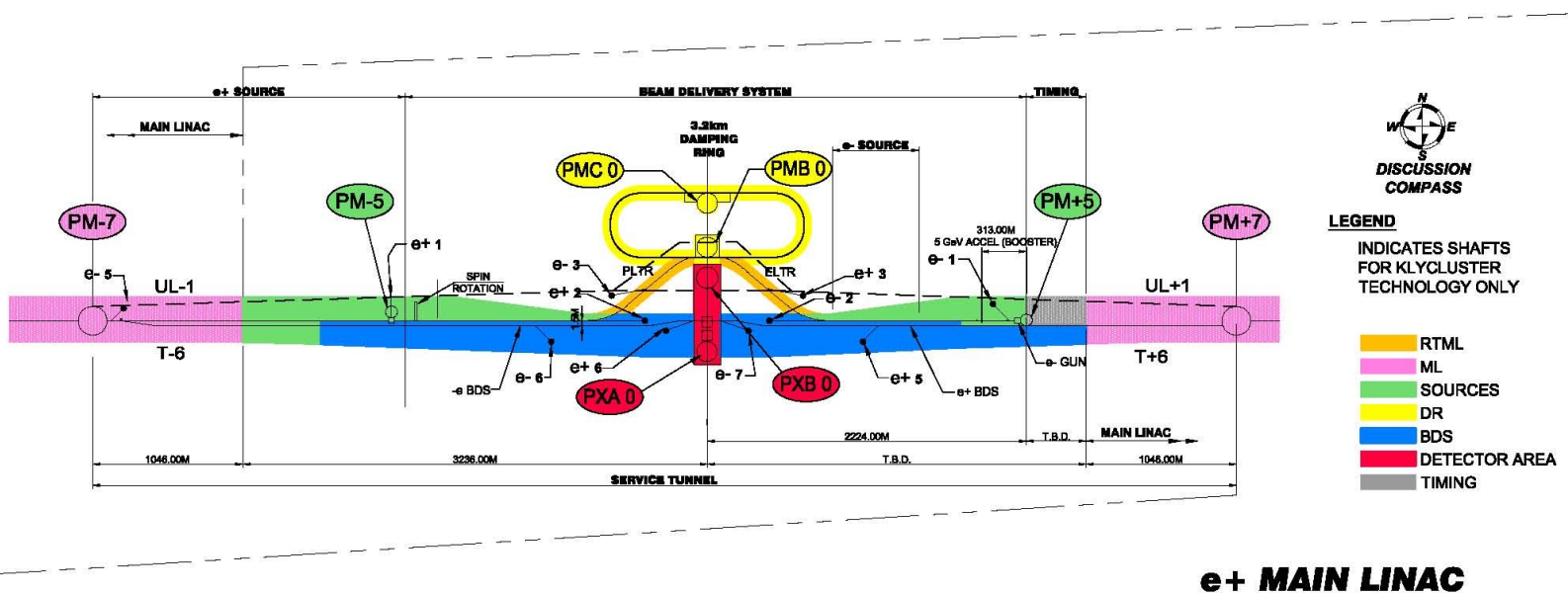

# RDR Cost

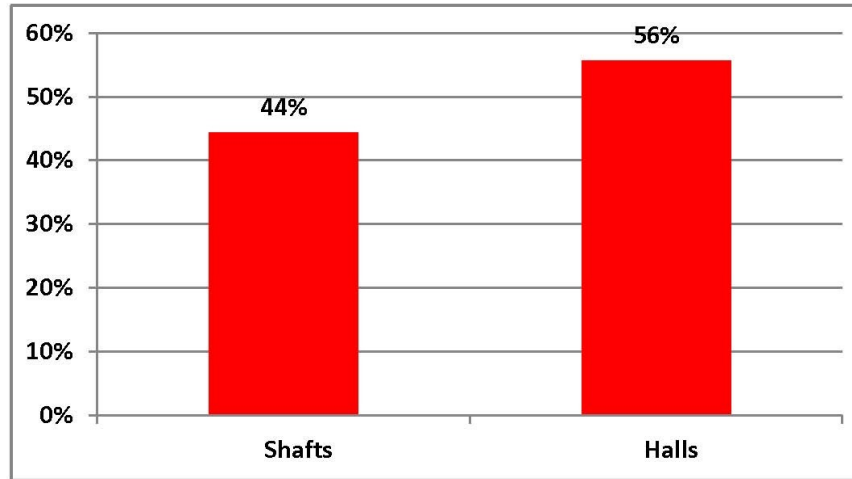
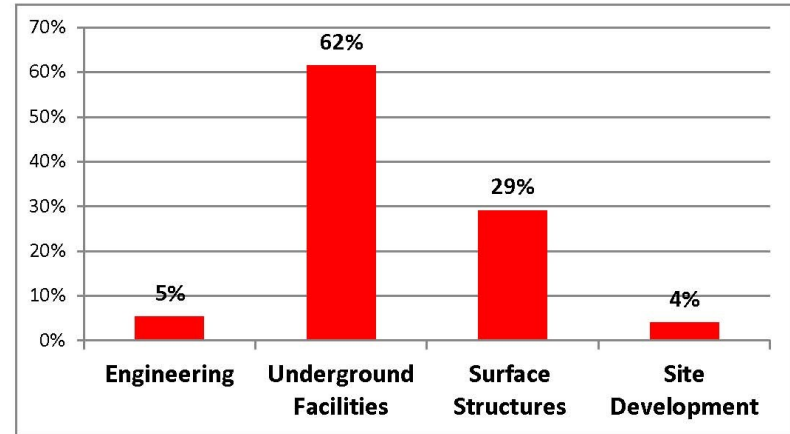
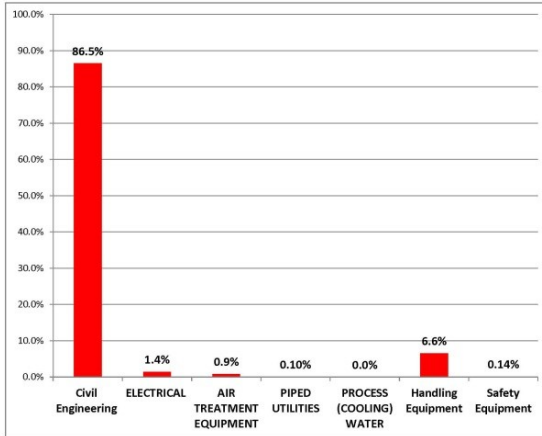

- Majority of Conventional Construction cost are the underground shaft and hall

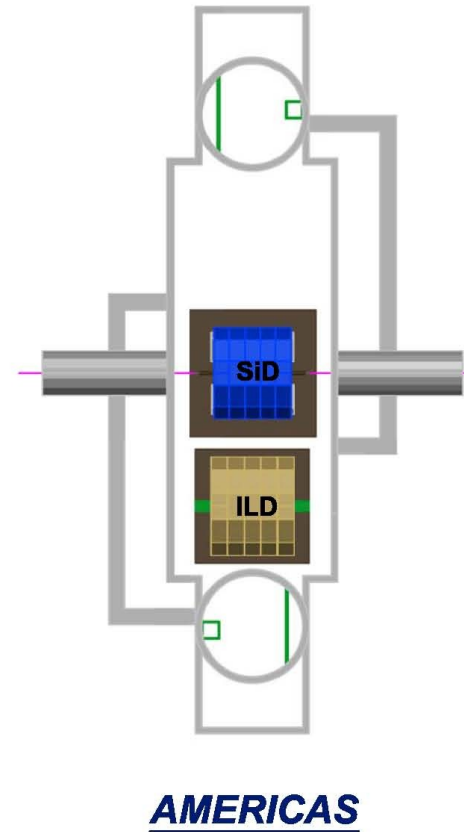
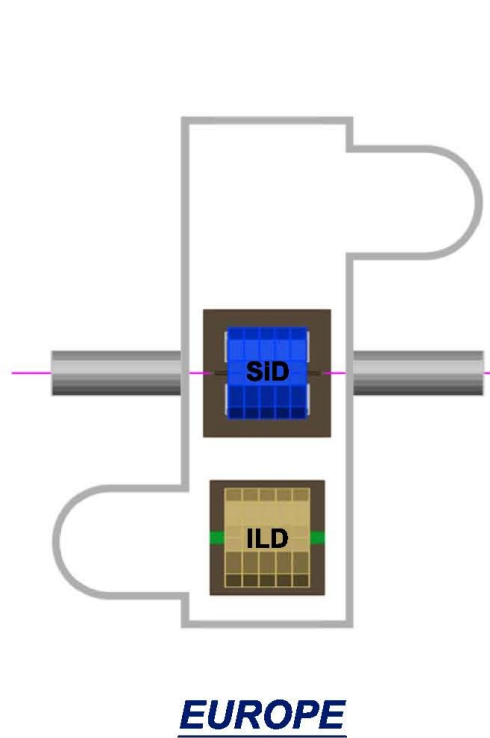
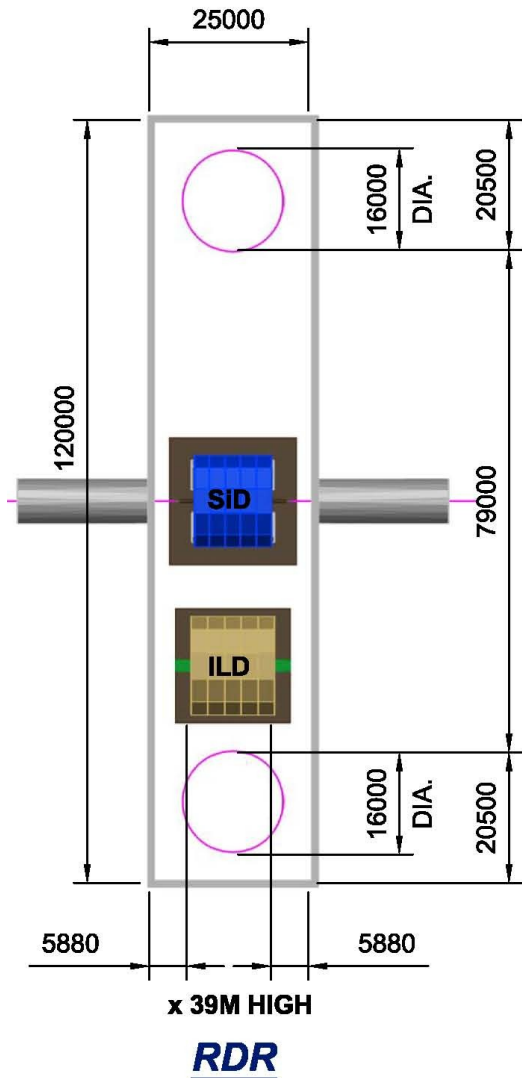

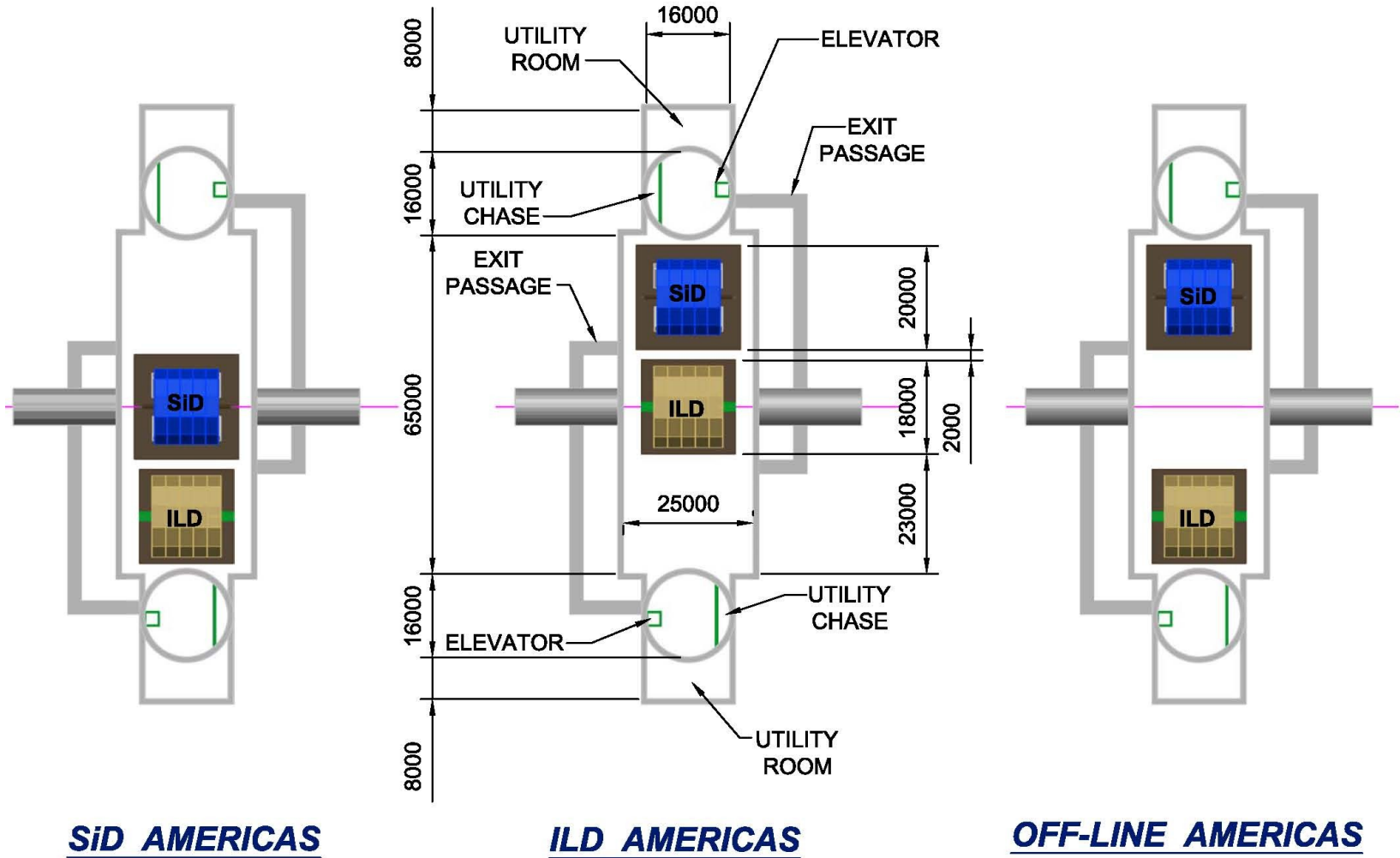

**SiD AMERICAS**

**ILD AMERICAS**

**OFF-LINE AMERICAS**



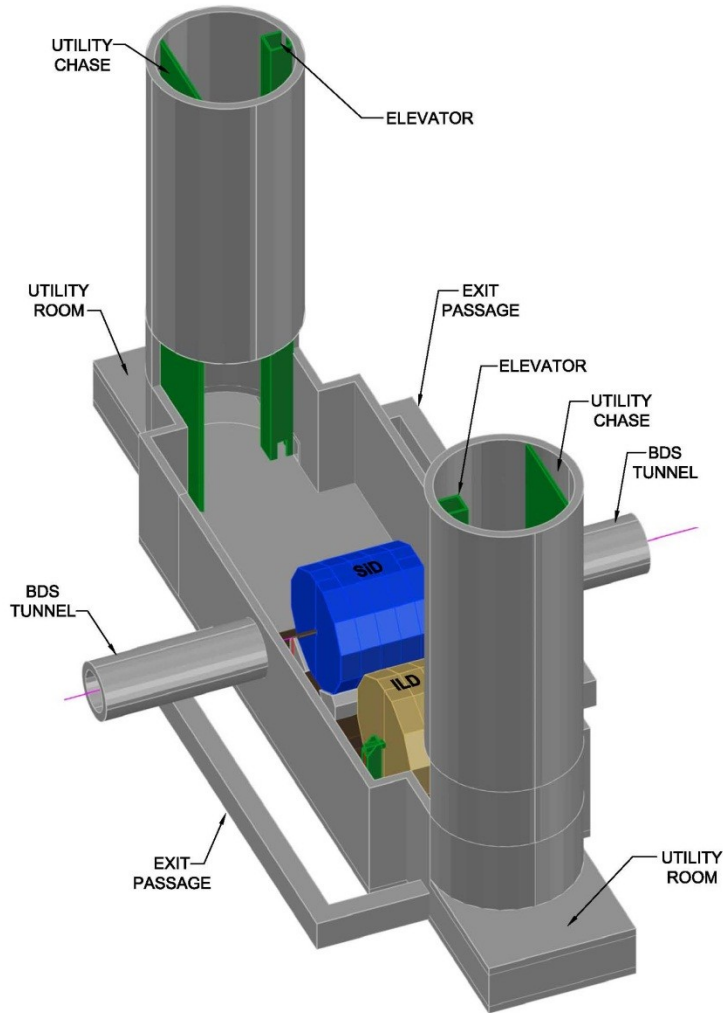

- Simple rock massing
- Uninterrupted roof spans and wall supports.



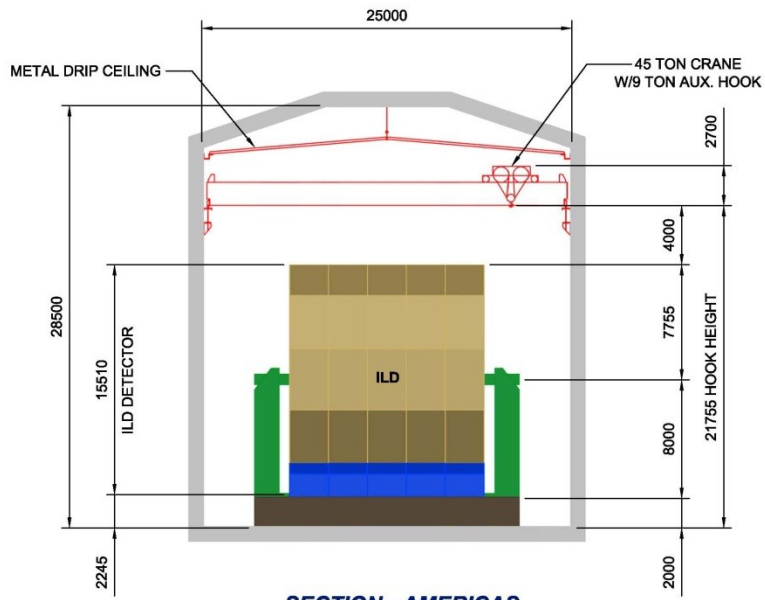

**SECTION - AMERICAS  
DETECTOR HALL**

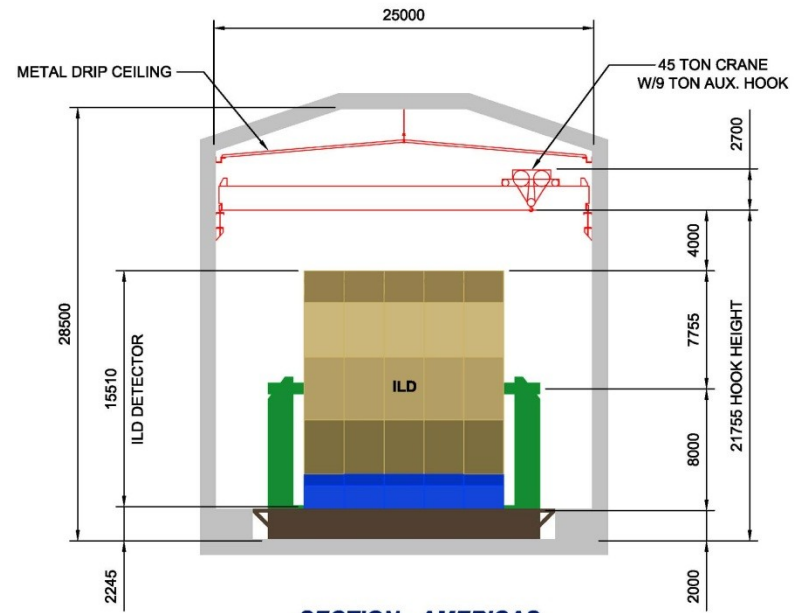

**SECTION - AMERICAS  
DETECTOR HALL**

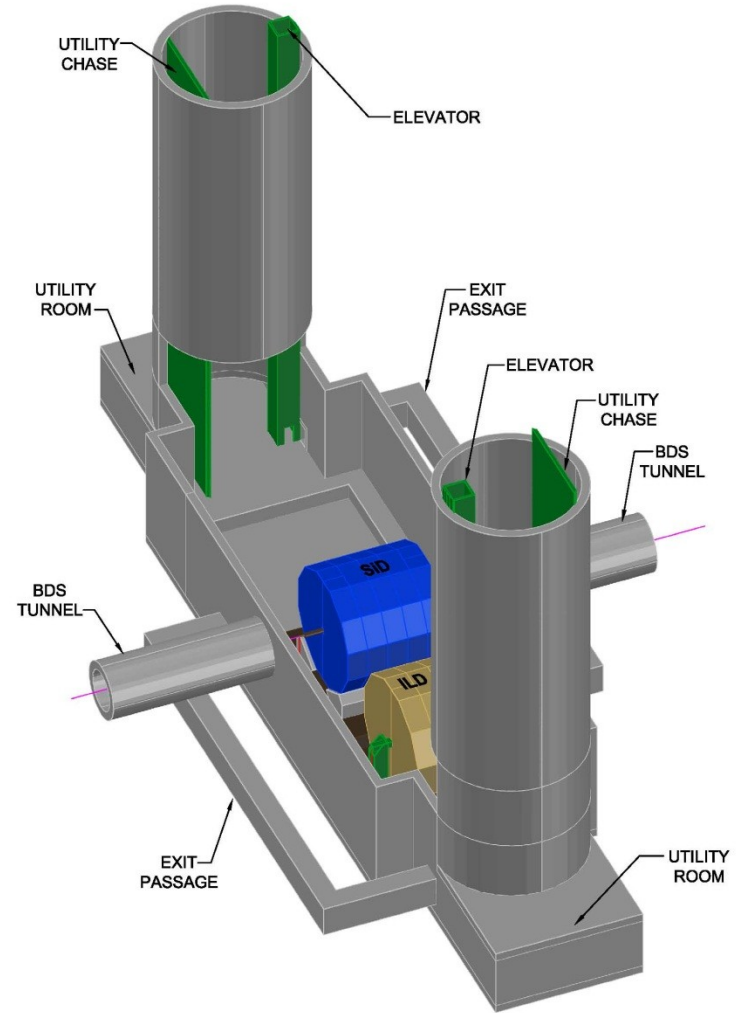
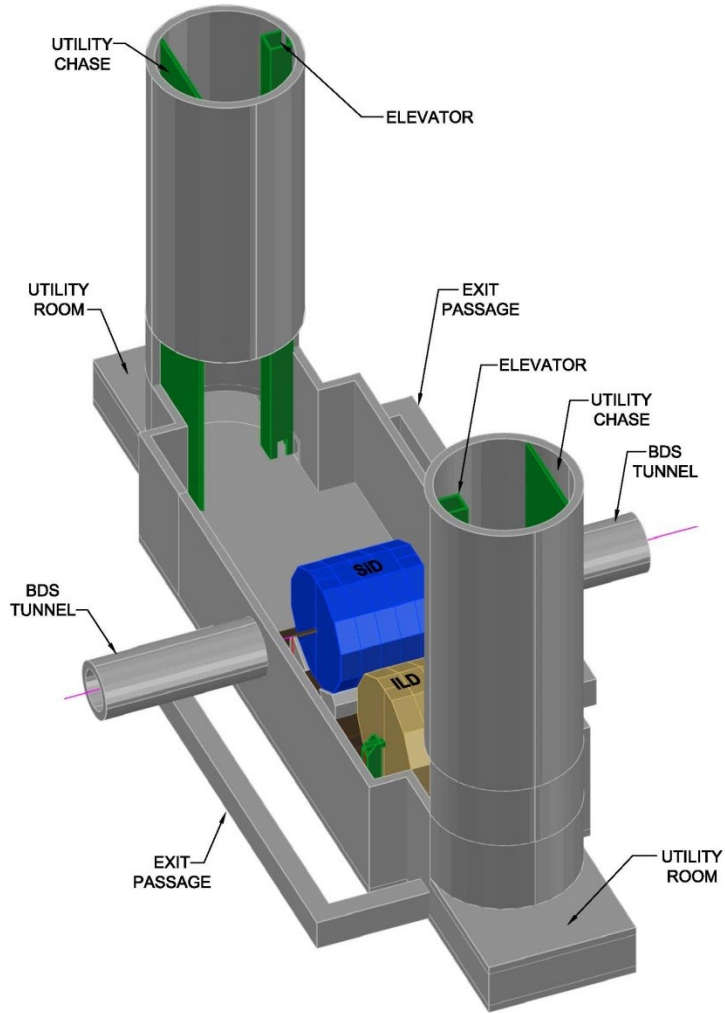

# Underground Discussions

- Hall Configuration wrt installation
- Platform in trench/pit
  - **Transport platform required if no trench**
  - **Greater access to moving system components**
  - **More flexibility between detectors**
- Ancillary Technical Space Requirements
  - **Control room**
  - **Fast Electronics/Counting Room**
  - **Access Stages**



# Underground Discussion

- Utility
  - **Water Systems**
  - **Electrical Systems**
  - **Cryo Systems**
- Pacman

BUILDING	DESCRIPTION	ILC SHAFT	BUILDING TYPE	BUILDING AREA								BUILDING COMPONENTS				
				LEVELS	HT	L	W	GSF /LEV	TOT GSF	QTY	TOT GSF	REST ROOMS	CRANE	OCCUPANCY	COMMENTS	
7	CONTROL ROOM	CONTROL DETECTOR & MACHINE BUILDING	SHAFTS 1.0 AND 1.1	LABORATORY	1	25	150	75	11,250	11,250	1	11,250	Y	N	65	
8	DETECTOR ASSEMBLY	DETECTOR ASSEMBLY BUILDING	SHAFTS 1.0 AND 1.1	INDUSTRIAL	1	75	300	75	22,500	22,500	2	45,000	Y	80T	30	HIGH BAY WITH MEZZANINE
10	M - D ACCESS	MACHINE & DETECTOR ACCESS BUILDING	SHAFTS 1.0 AND 1.1	INDUSTRIAL	1	60	300	75	22,500	22,500	1	22,500	Y	280T	30	HIGH BAY WITH MEZZANINE
14	ELECTRICAL	ELECTRICAL BUILDING	SHAFT 1.0 AND 1.1	INDUSTRIAL	1	20	50	30	1,500	1,500	1	1,500	N	N	0	
19	CV BUILDING	COOLING VENTILATION BUILDING	SHAFTS 1.0 AND 1.1	UTILITY	1	40	75	75	5,625	5,625	2	11,250	N	N	0	

BUILDING AREA								BUILDING COMPONENTS			
LEVELS	HT	L	W	GSF /LEV	TOT GSF	QTY	TOT GSF	REST ROOMS	CRANE	OCCUPANCY	COMMENTS
1	25	150	75	11,250	11,250	1	11,250	Y	N	65	
1	75	300	75	22,500	22,500	2	45,000	Y	80T	30	HIGH BAY WITH MEZZANINE
1	60	300	75	22,500	22,500	1	22,500	Y	280T	30	HIGH BAY WITH MEZZANINE
1	20	50	30	1,500	1,500	1	1,500	N	N	0	
1	40	75	75	5,625	5,625	2	11,250	N	N	0	



# Surface Buildings Discussion

- Receiving / Staging
- Detector Assembly Space
  - **Work space for construction**
    - Dirty spaces / Clean spaces
  - **Final assembled for testing**
  - **Sub-assemble fabrication / testing**
- Shop space
- Utilities
- Crane (80 ton)

DETECTOR CONVENTIONAL PARAMETERS

ITEM	ILC	SID
<b>Underground Hall</b>		
Detector Dimensions		
Lenght (Between PacMan)		
Lenght (in Open Position in Beam)		
Lenght (in open Position in Garage)		
Width Transverse to beam	15.51	
Detector Height Above Beam	7.755	
Platforms		
Height		
Distance Below Beam		
Width (Between PacMan)		
Transverse to beam		
Stiffness Requirements		
Platform Moveing System		
Provides final alignment of detector wrt beam		
Weights		
Total		
(Plan view load diagrams are needed to design platform. Diagrams are needed for anticipated configurations)		
Crane		
Main Hook Capacity		
Aux Hook Capacity		
Hook Height above Detector		
Occupancy		
During Installation		
During Operations		
During Maintenance		
Control Room		



DETECTOR CONVENTIONAL PARAMETERS

ITEM	ILC	SID
Creature Com Toilets		
Break Rooms		
<b>Shafts</b>		
<b>Surface Buildings</b>		