

# GLD Calorimeter

Tohru Takeshita

Shinshu U. for GLD-CAL group

ILC

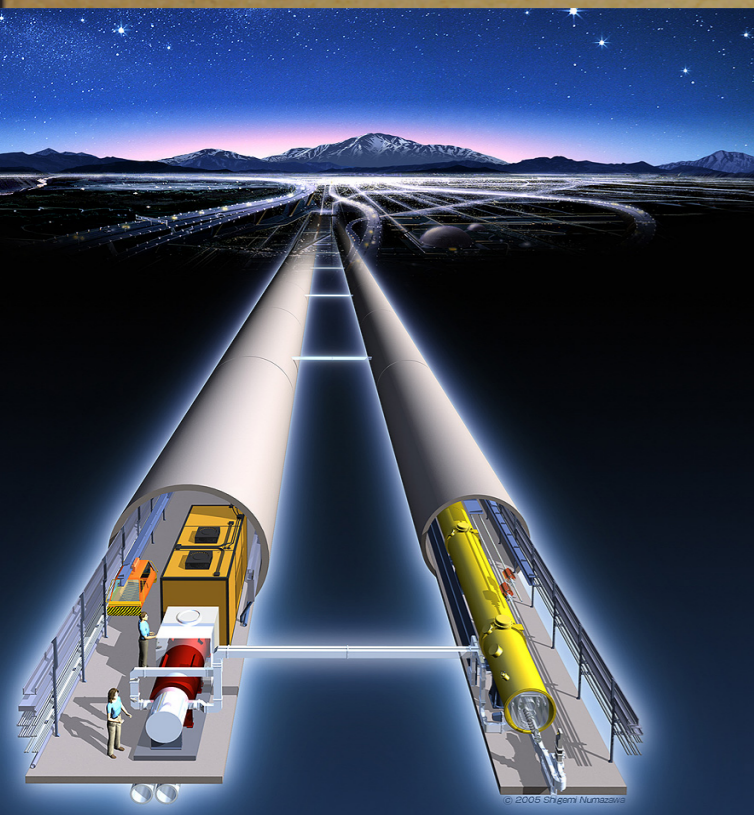

outline  
concept  
implementation  
experience  
outlook

GLD

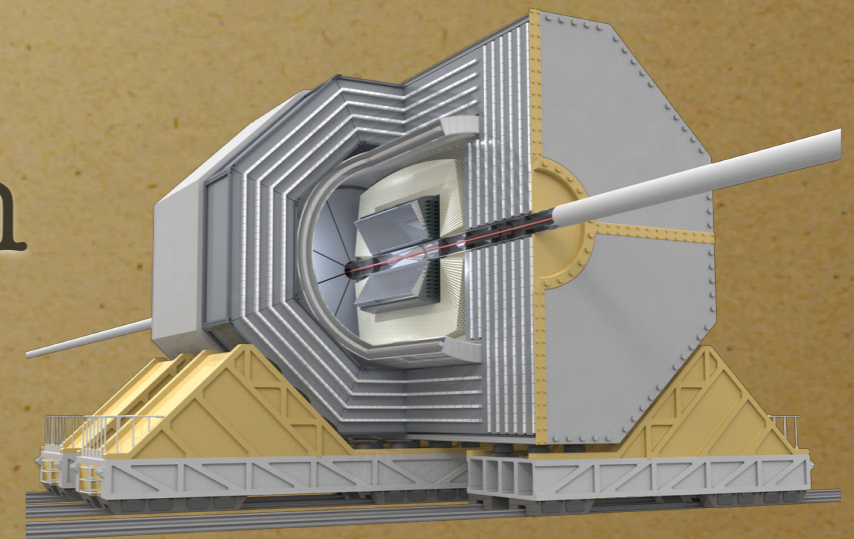



# ILC and its Physics

- $e^+e^-$  collision with  $\sim 1\text{TeV}$  Linear Collider
- Final states will be dominated by narrow jets
- Jets come from  $W/Z/g/q$
- Task : identify these partons / gauges boson from Jets

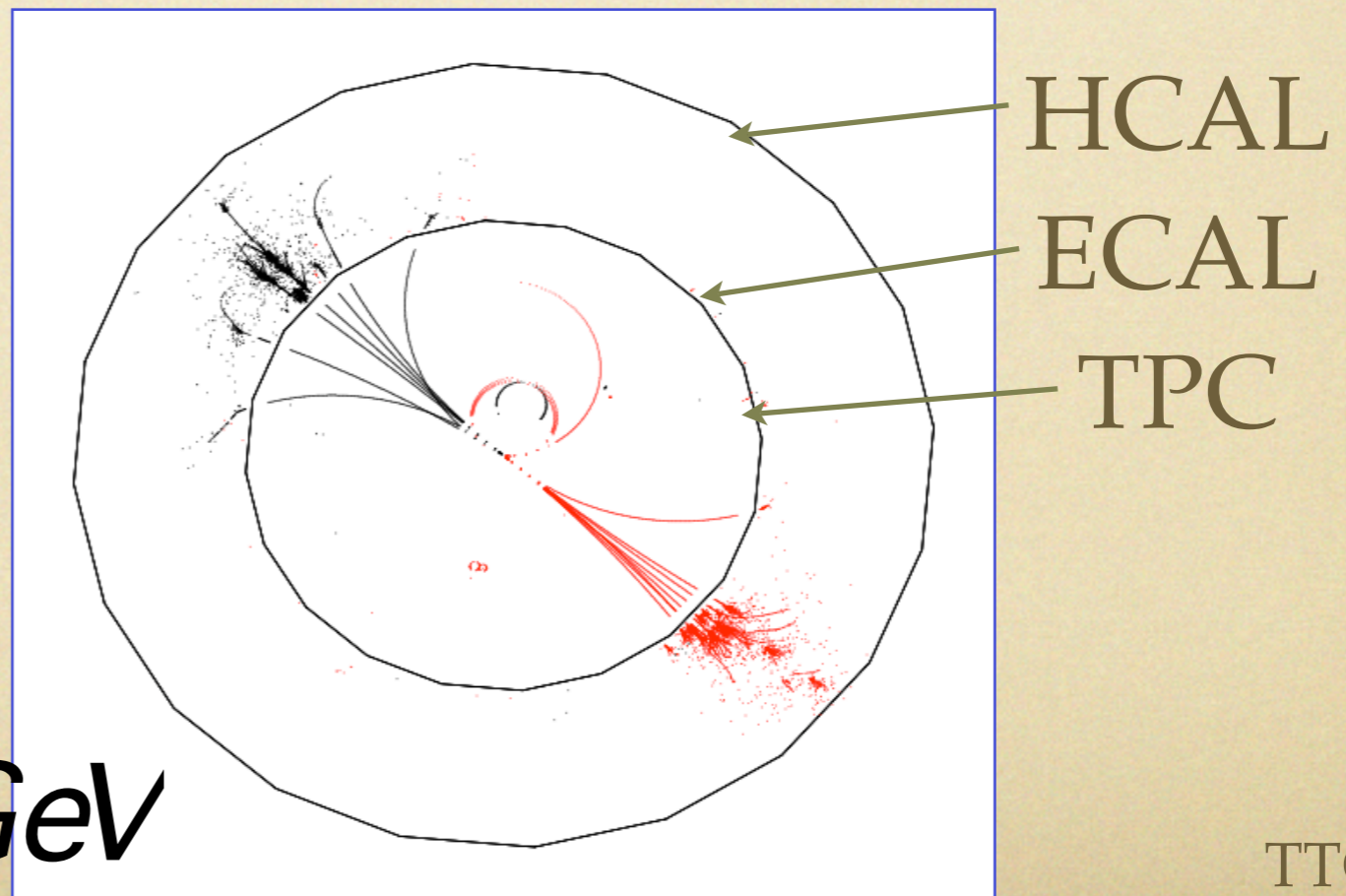

$e^+e^- \rightarrow q\bar{q} @ 350\text{GeV}$

# Particle Flow oriented

Jet is measured by

- Tracker : charged 65% in a jet
- ECAL : photon 25 % in a jet
- HCAL : neutral hadron 10% in a jet

$e^+e^- \rightarrow WW$  at 250GeV

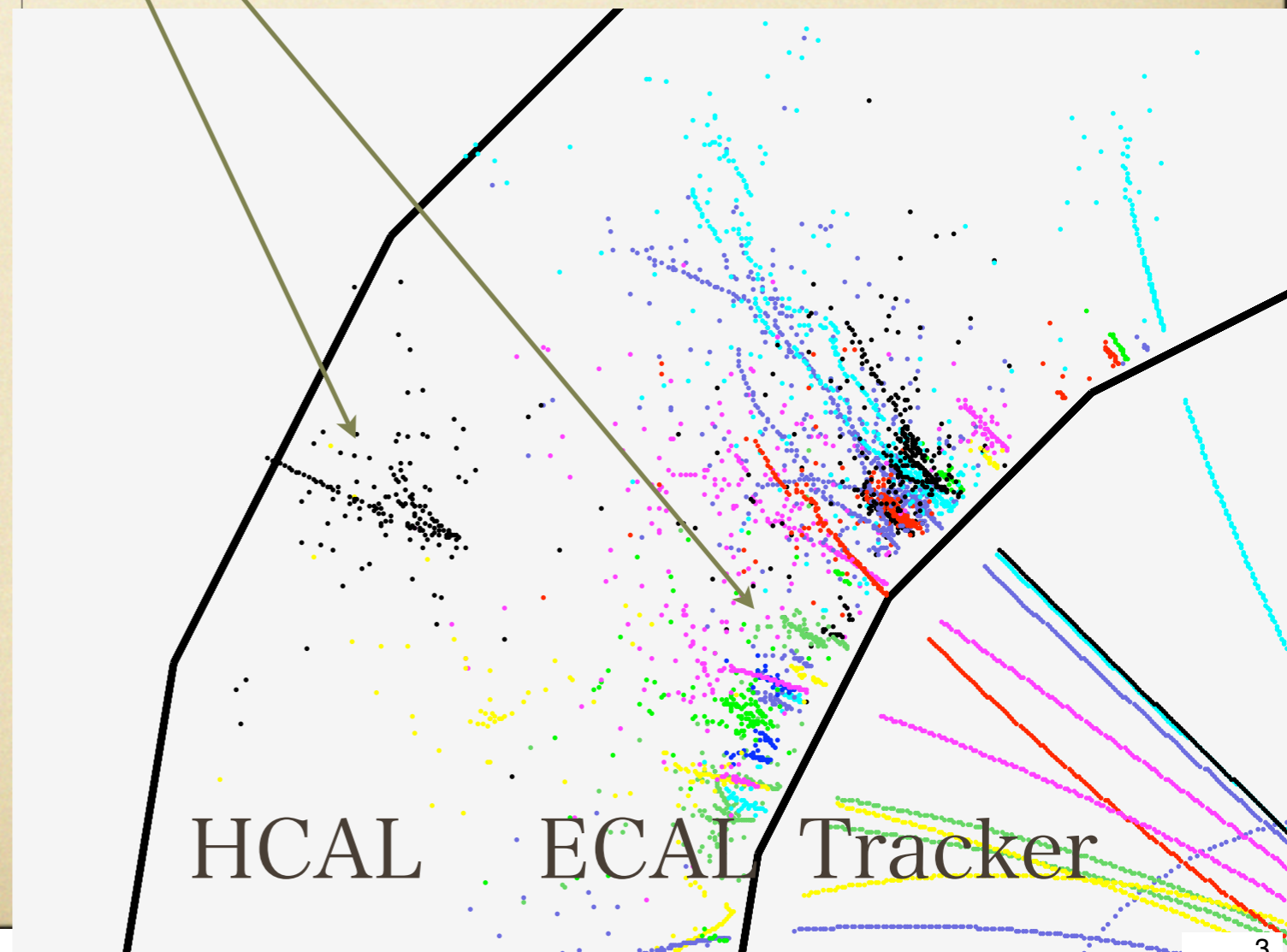
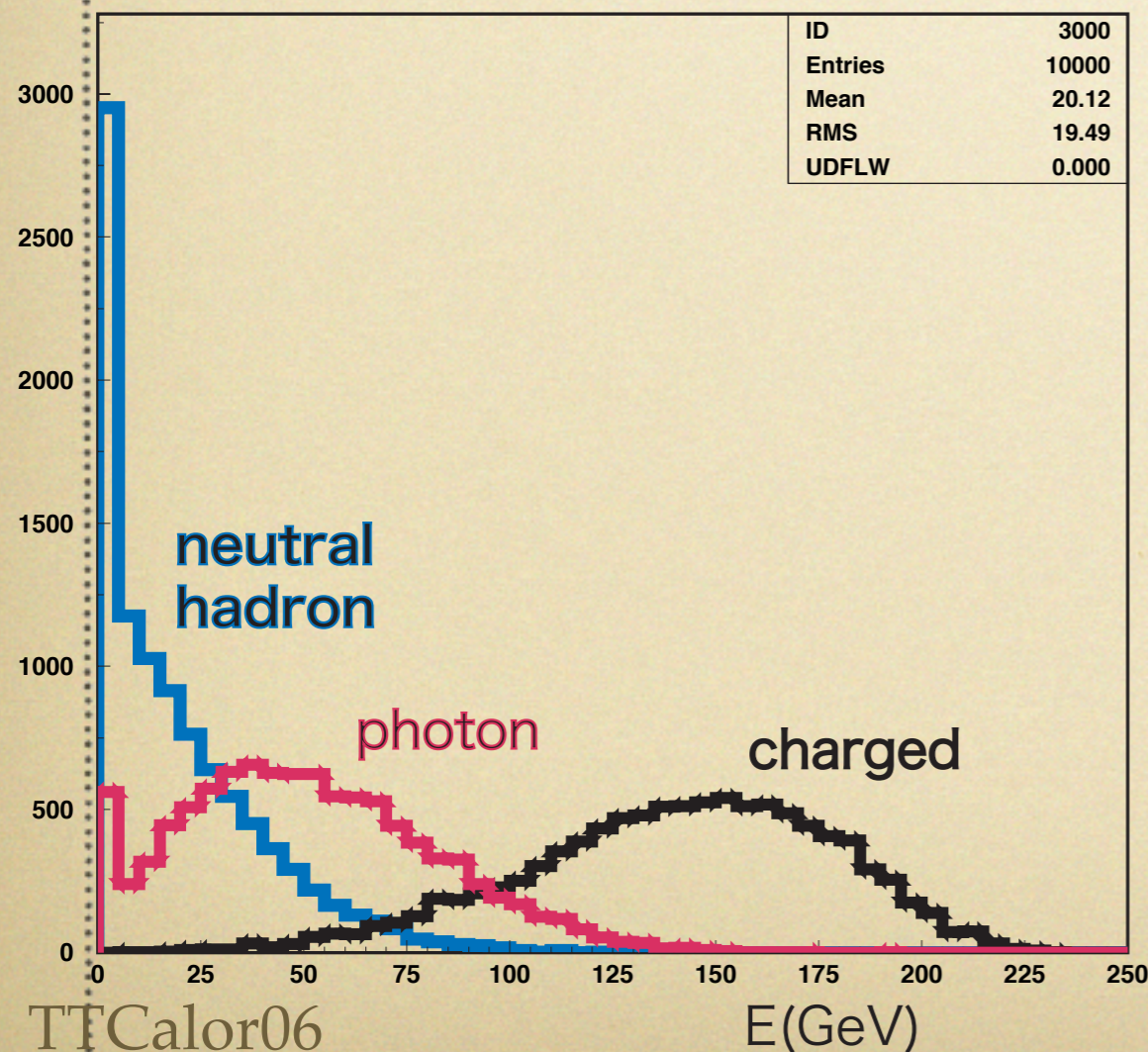

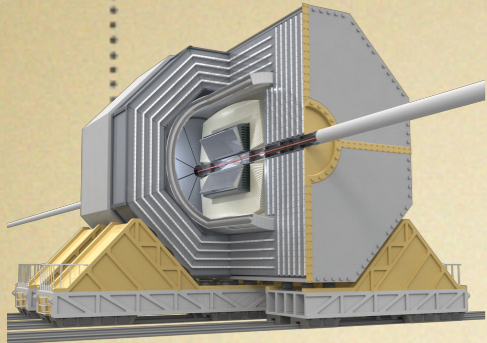

# GLD Concepts

- Large detector
  - to measure pi-zero (ECAL)
  - to measure neutral hadrons (HCAL)
- smaller segmentation

Large

Small

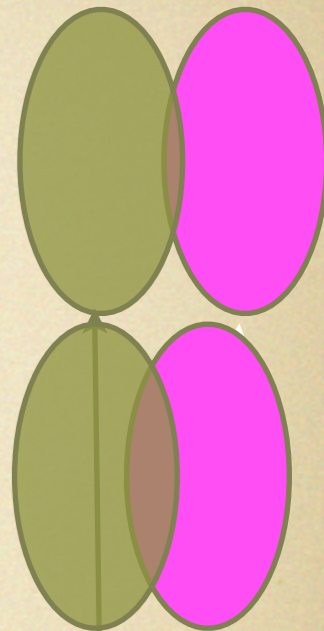

pi-zero

2gammaDistance@210cm pi0:4,10,20,50gev

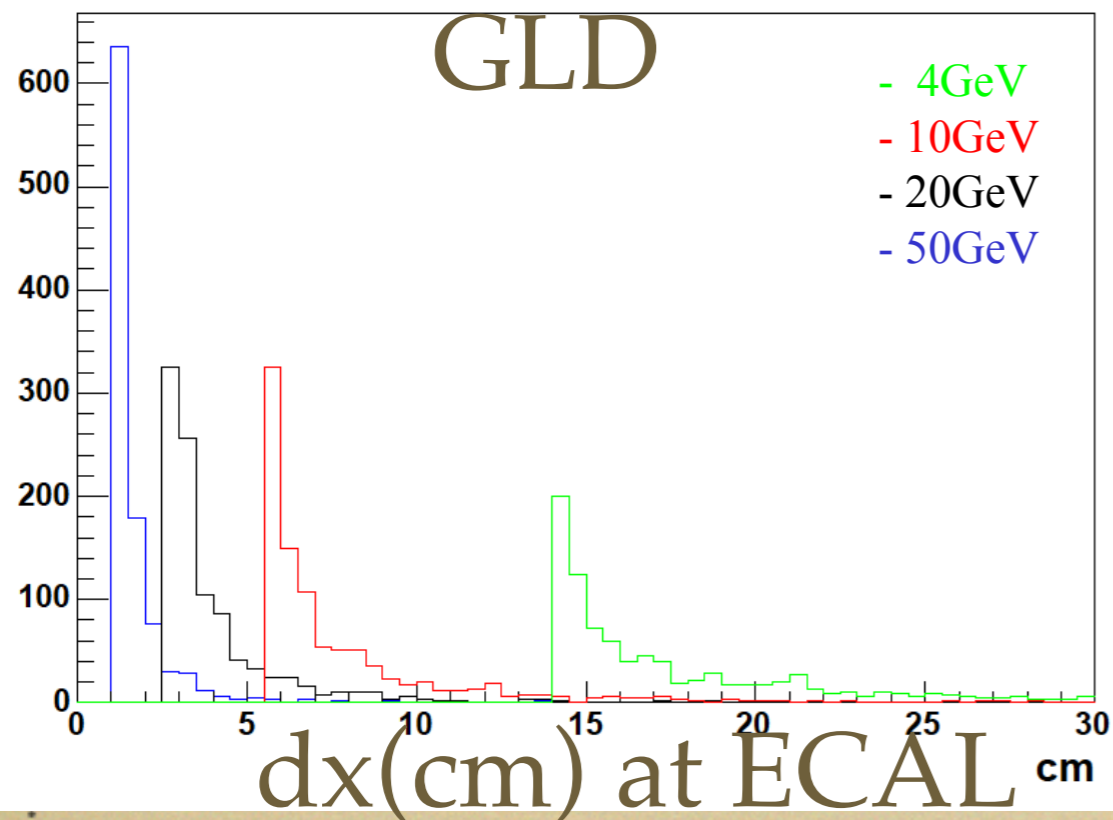

dx(cm)

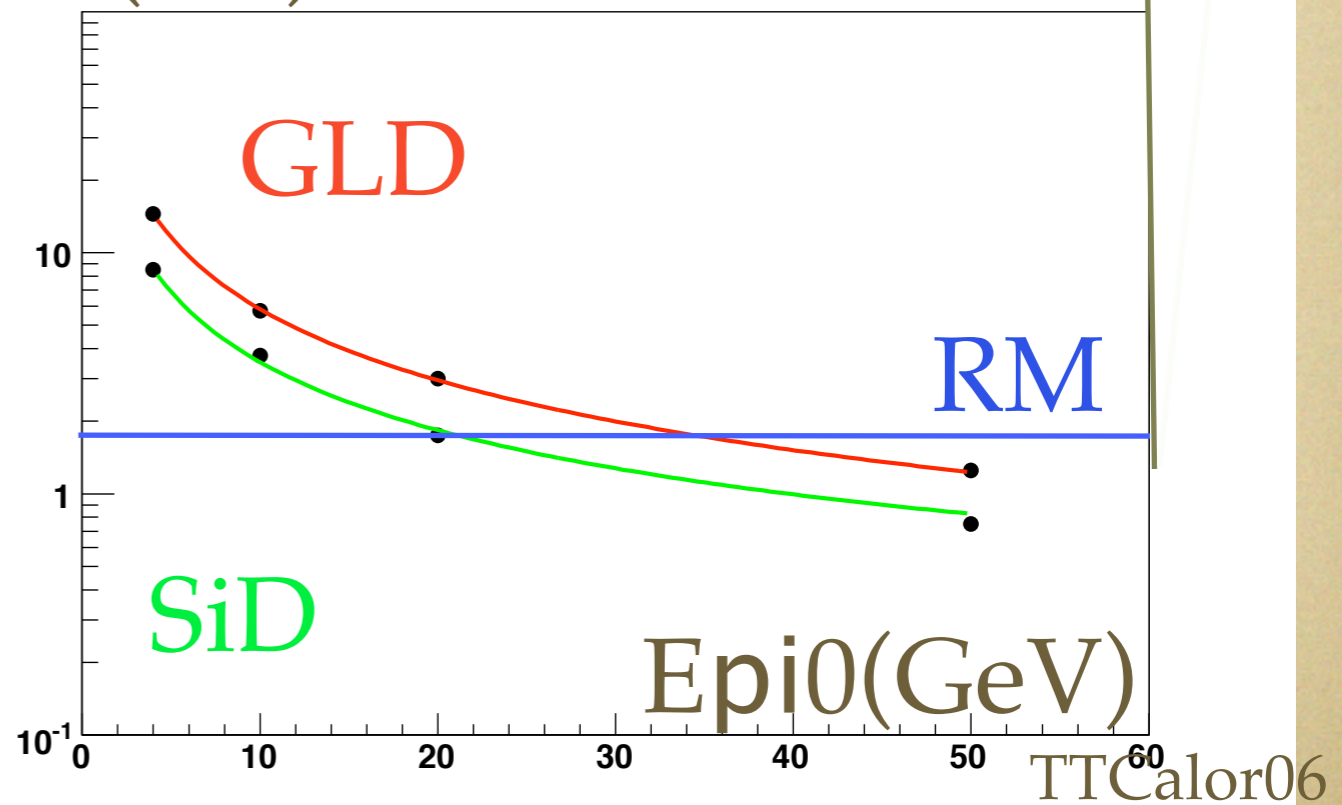

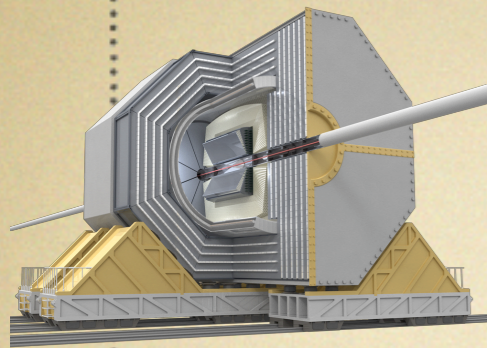

# GLD features

- to identify and measure particles in a jet
- Large detector + super conducting magnet
- HCAL inside coil (3.5m diameter max)
- Largest TPC (Tracker : 2m dia.)

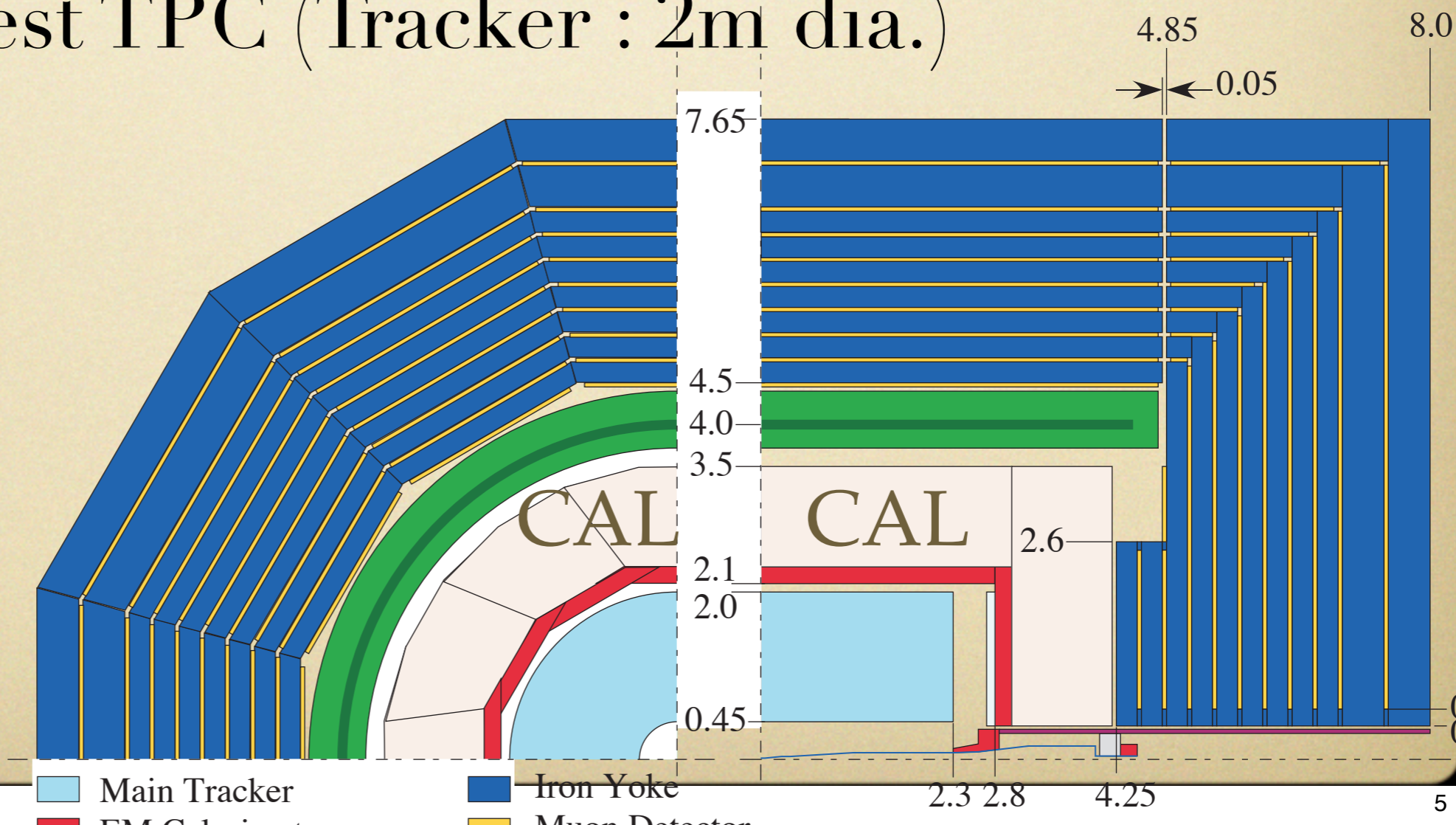

# GLD-Calorimeter

- **scintillator strip calorimeter**
- ECAL :  $R = 2.1 \sim 2.3 \text{ m}$  (0.2m) :
  - 6 mm / layer ( 3 + 2 + 1)mm
  - 33 layers, 28X0
- HCAL :  $R = 2.3 \sim 3.5 \text{ m}$  (1.2m) :
  - 26 mm / layer ( 20 + 5 + 1)mm
  - 46 layers , 5.5 mint

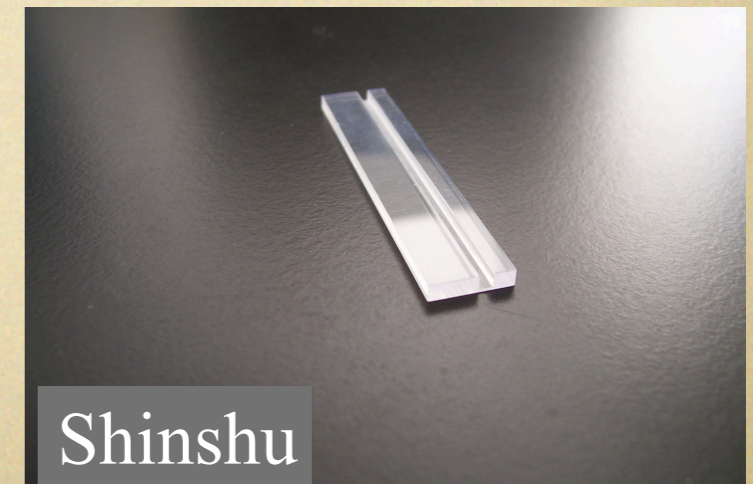
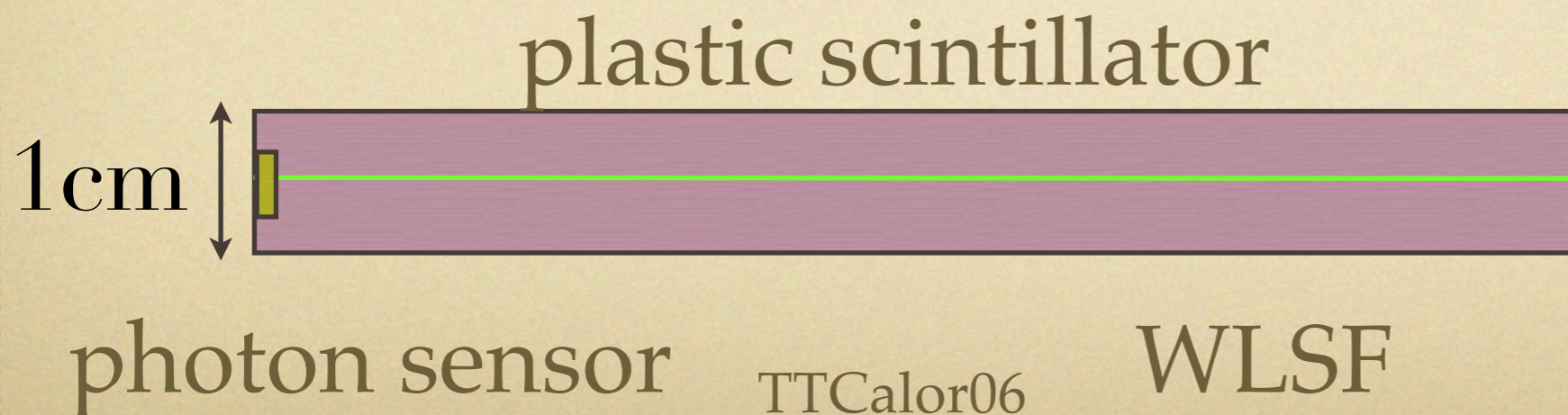

Shinshu

# GLD-Calorimeter cont.

## GLD-ECAL-Scintillator-layer model

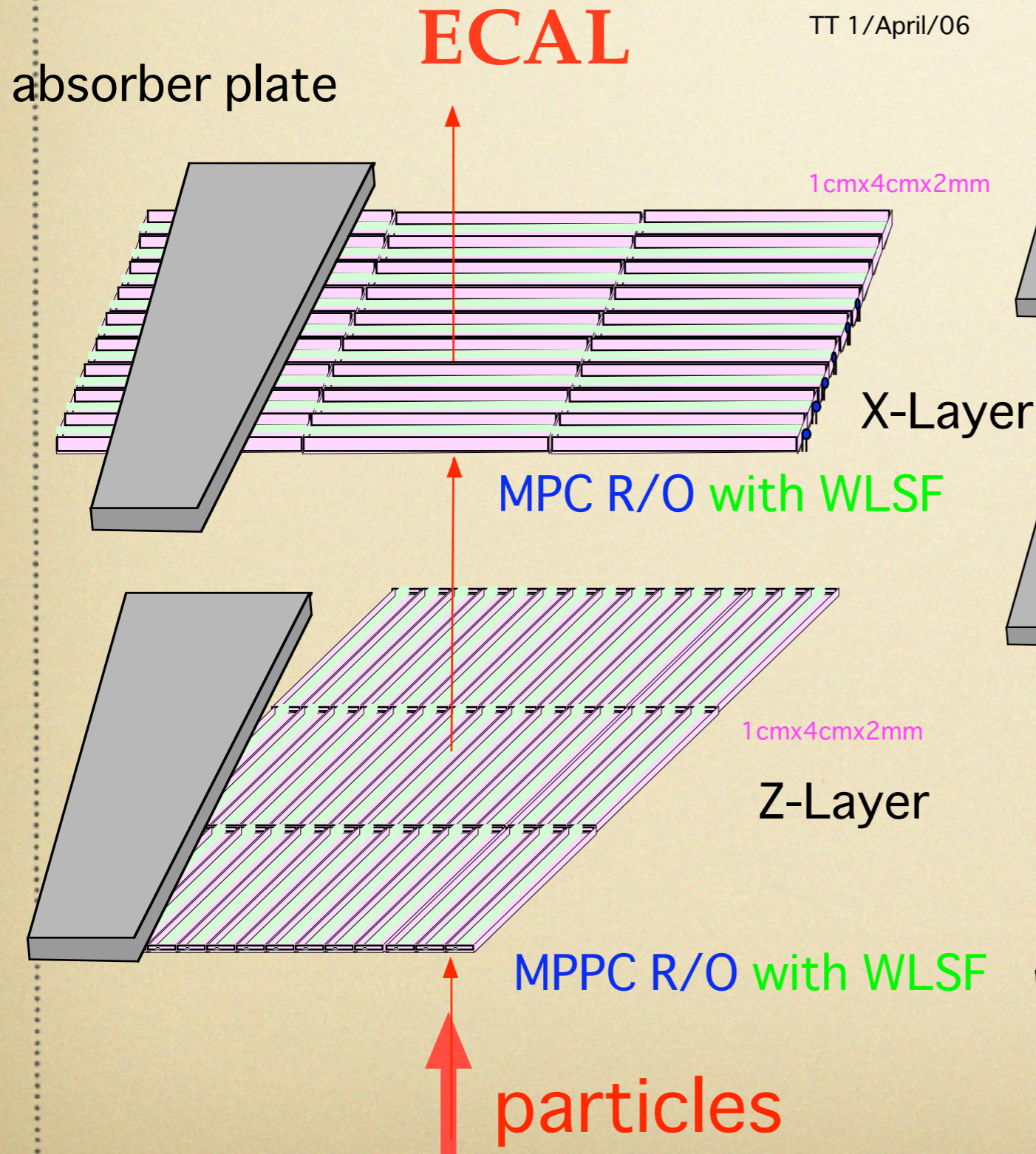

## HCAL-Scintillator-layer model

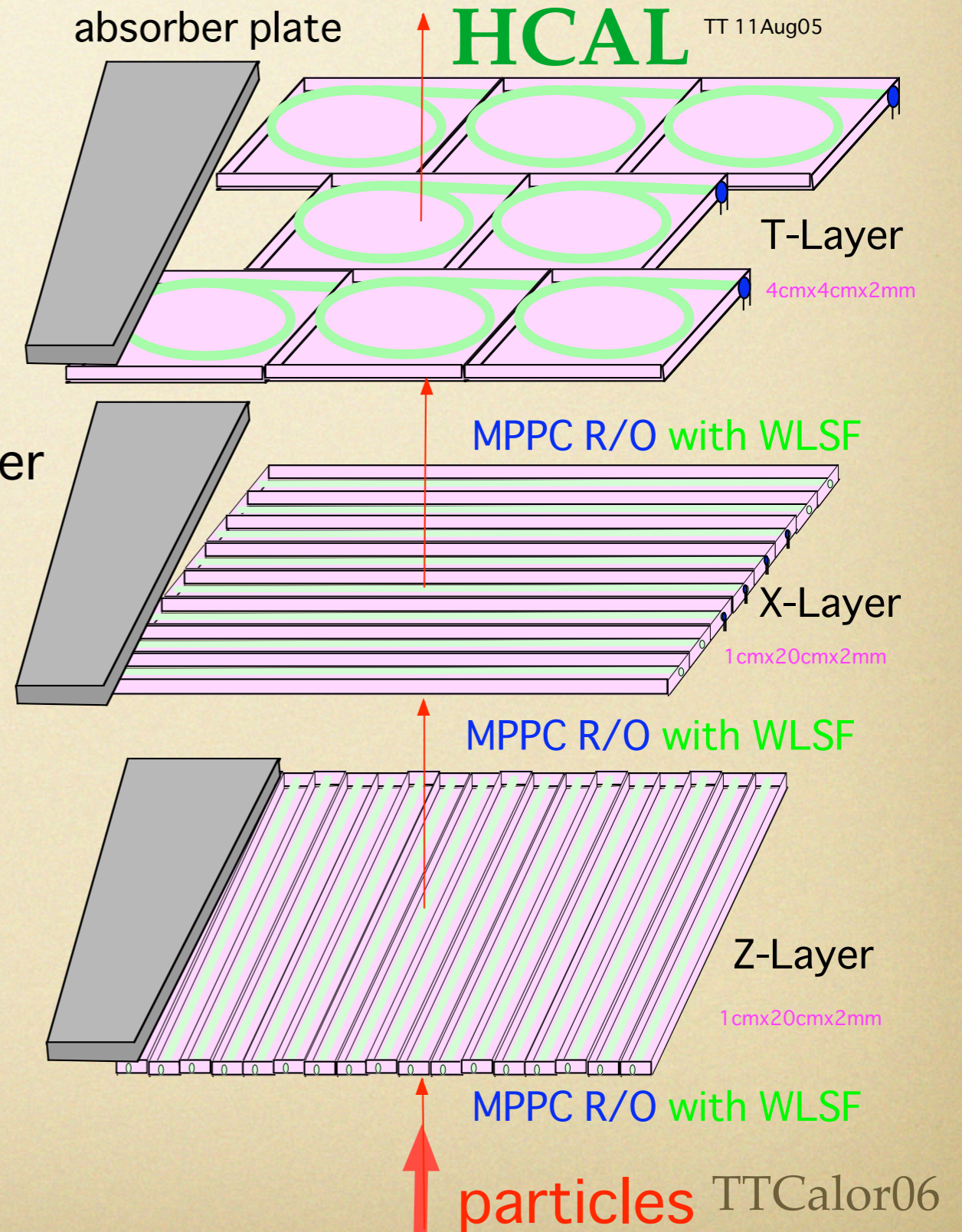

# GLD-Calorimeter cont.

HCAL-Scintillator-layer model

TT 01 April 06

## ECAL

EM-Scintillator-layer model  
Cross section

TT 1 April 06

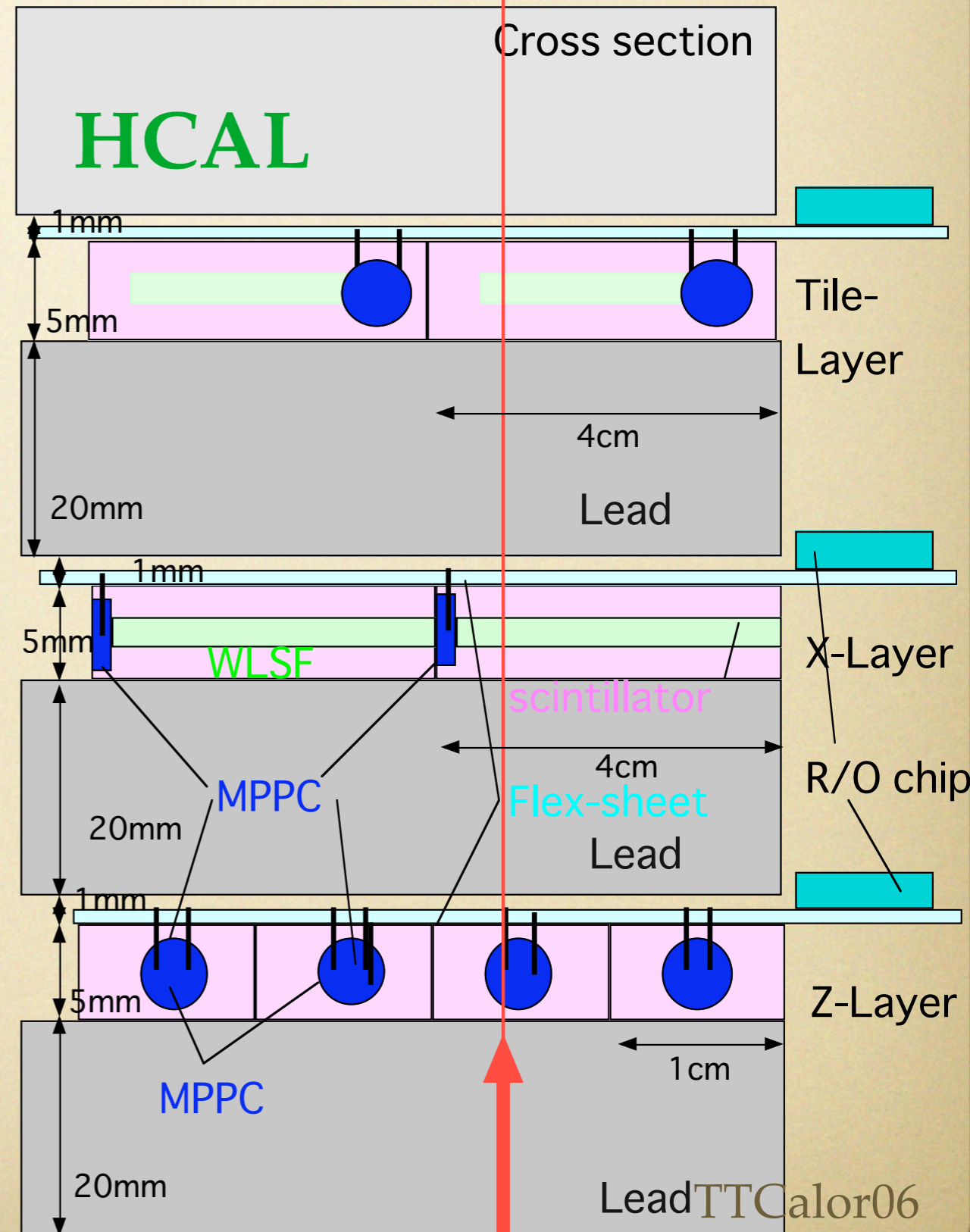
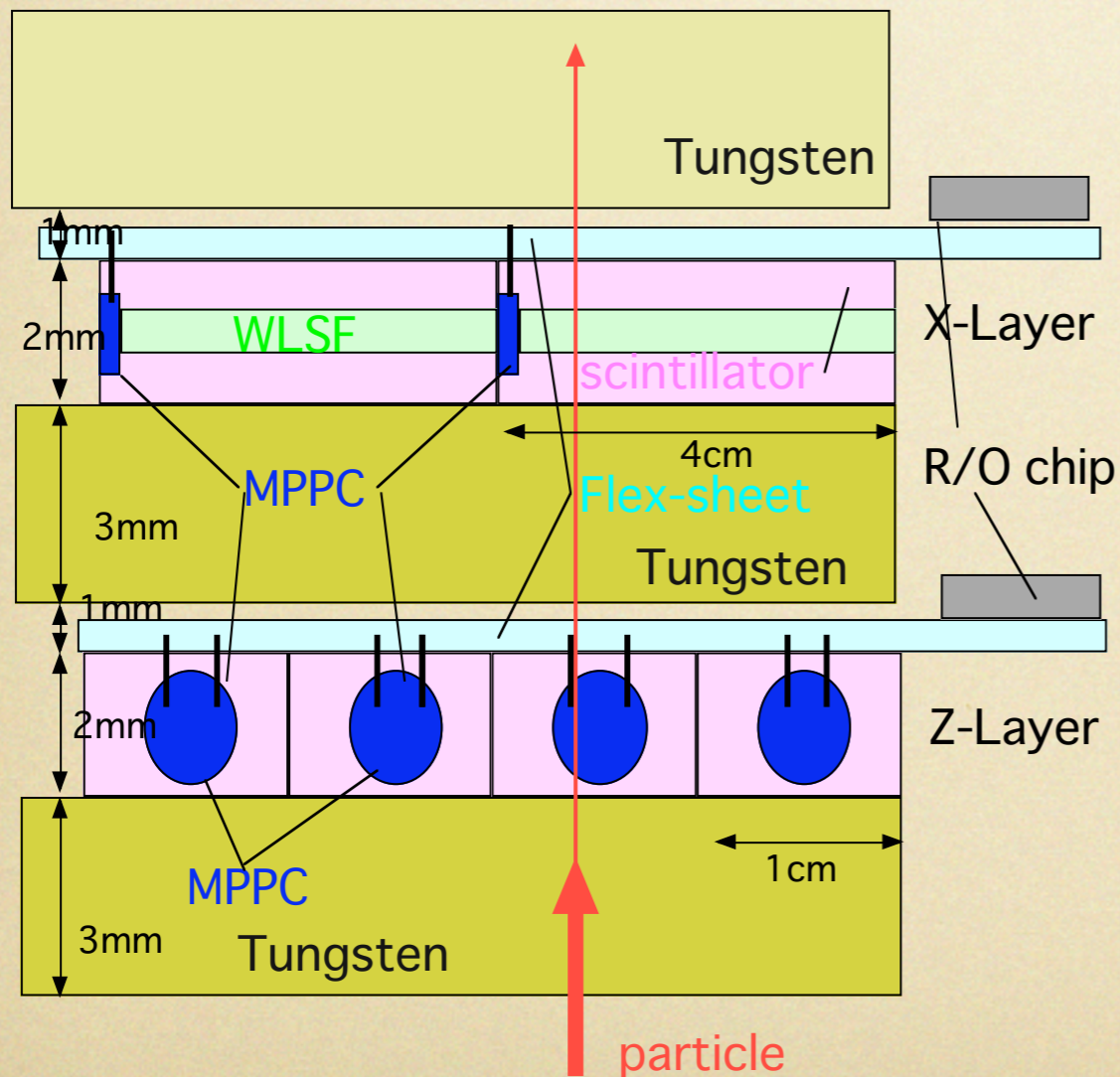

TT Calor 06

particle



# GLC-CAL parameters

	absorber	active material	Layers barrel/ec	strip length	N. R/O
<b>ECAL</b>	W 3mm	scintillator 2mm	33/ 33	5cm?	~10M ch
<b>HCAL</b>	Pb 20mm <b>compensating</b>	scintillator 5mm	46/ 48	20cm?	~4M ch

# scintillator strip CAL. experience

## ECAL test with MAPMT

20cmx1cmx2mm  24layers

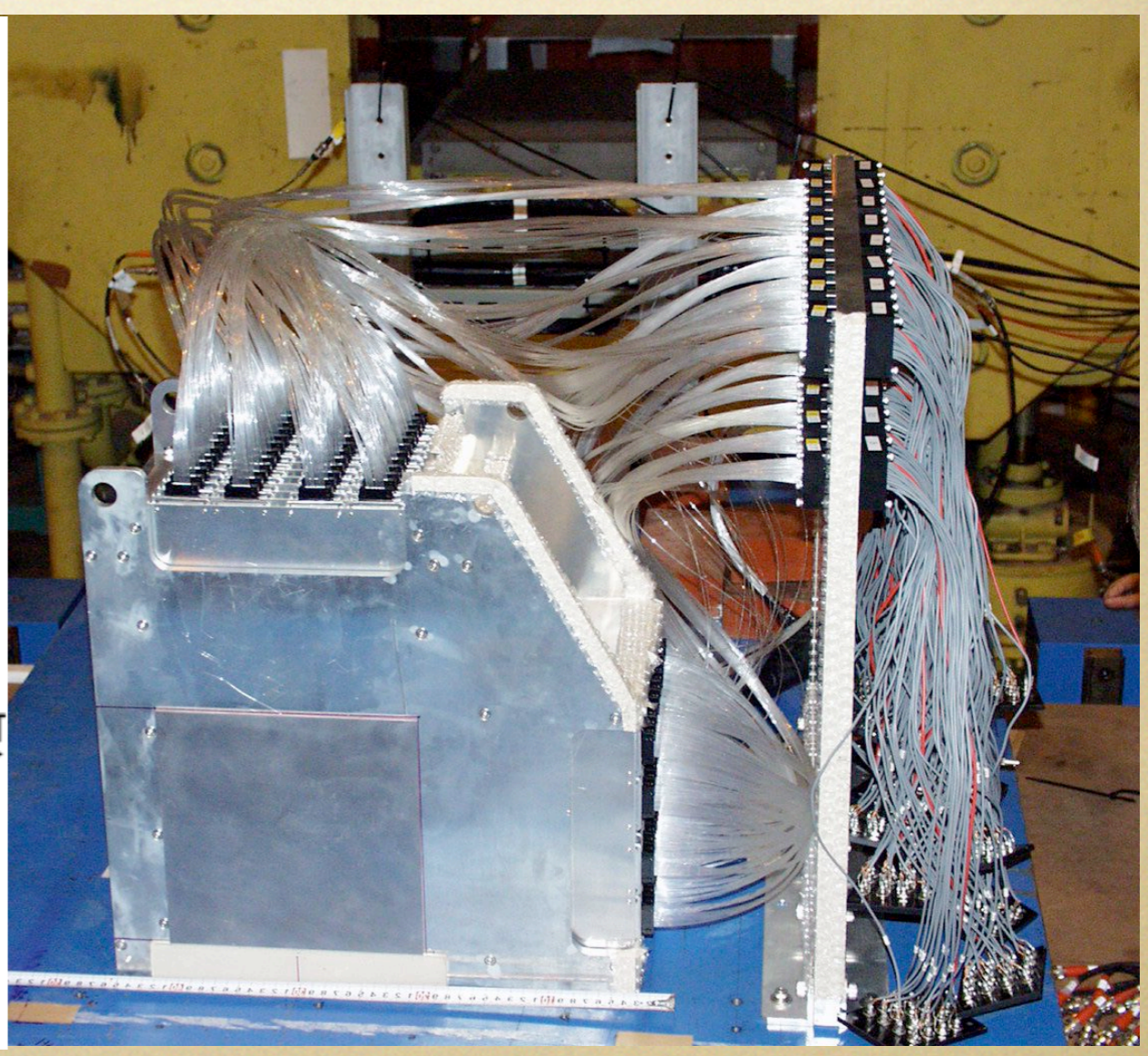
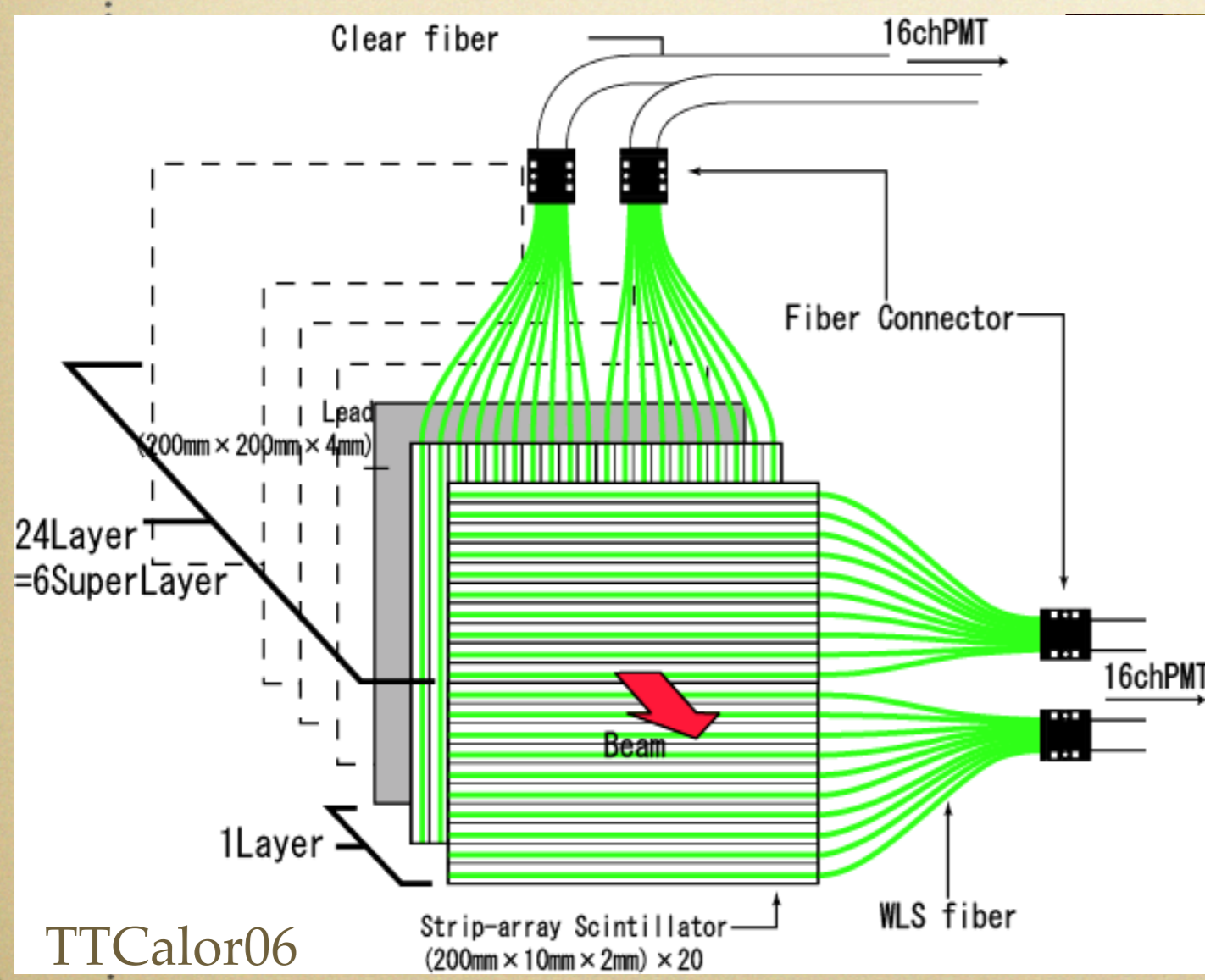

# SSCAL experinice cont.

pictorial detector  
a typical event

Integrated lateral shower profile

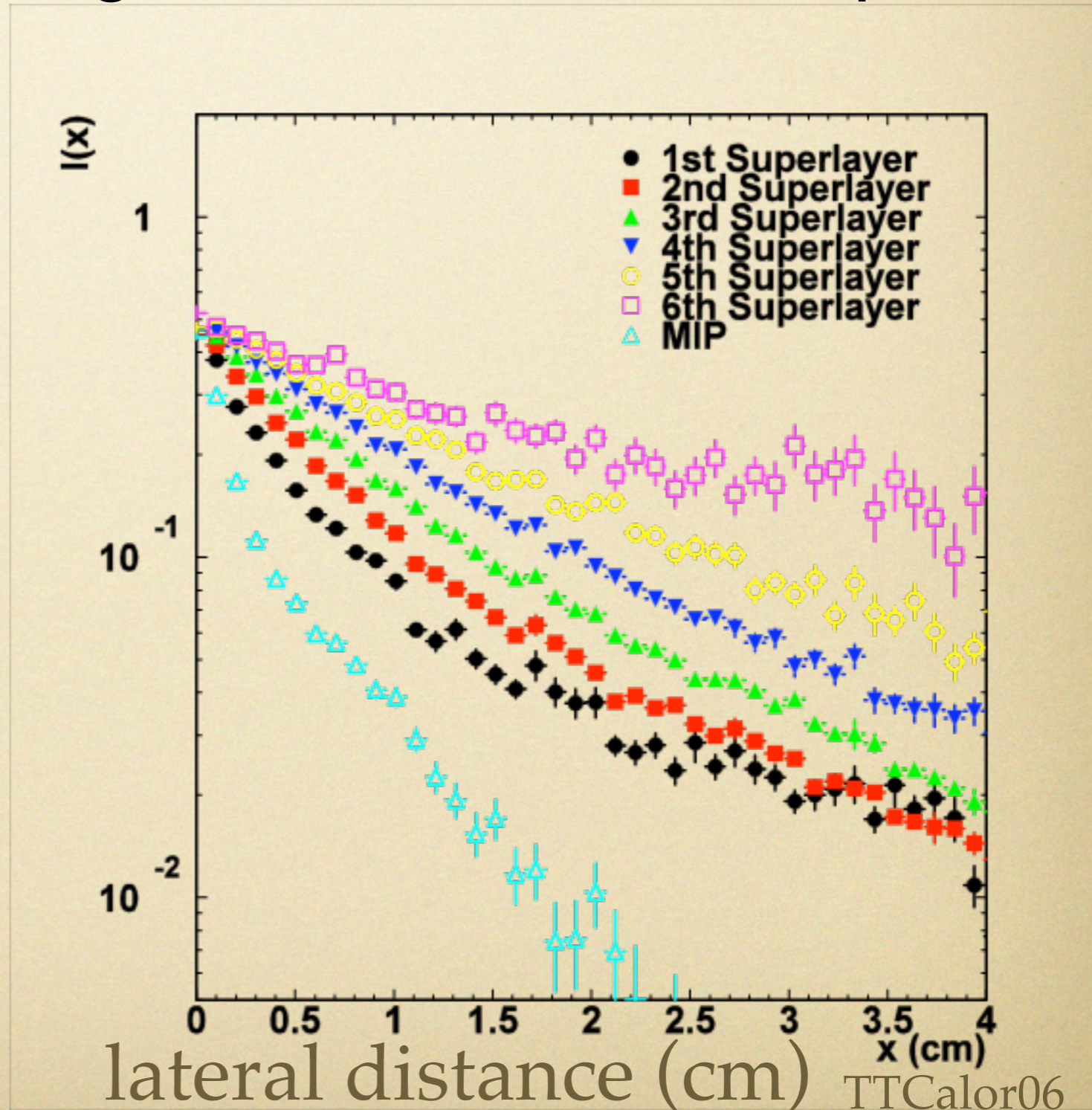
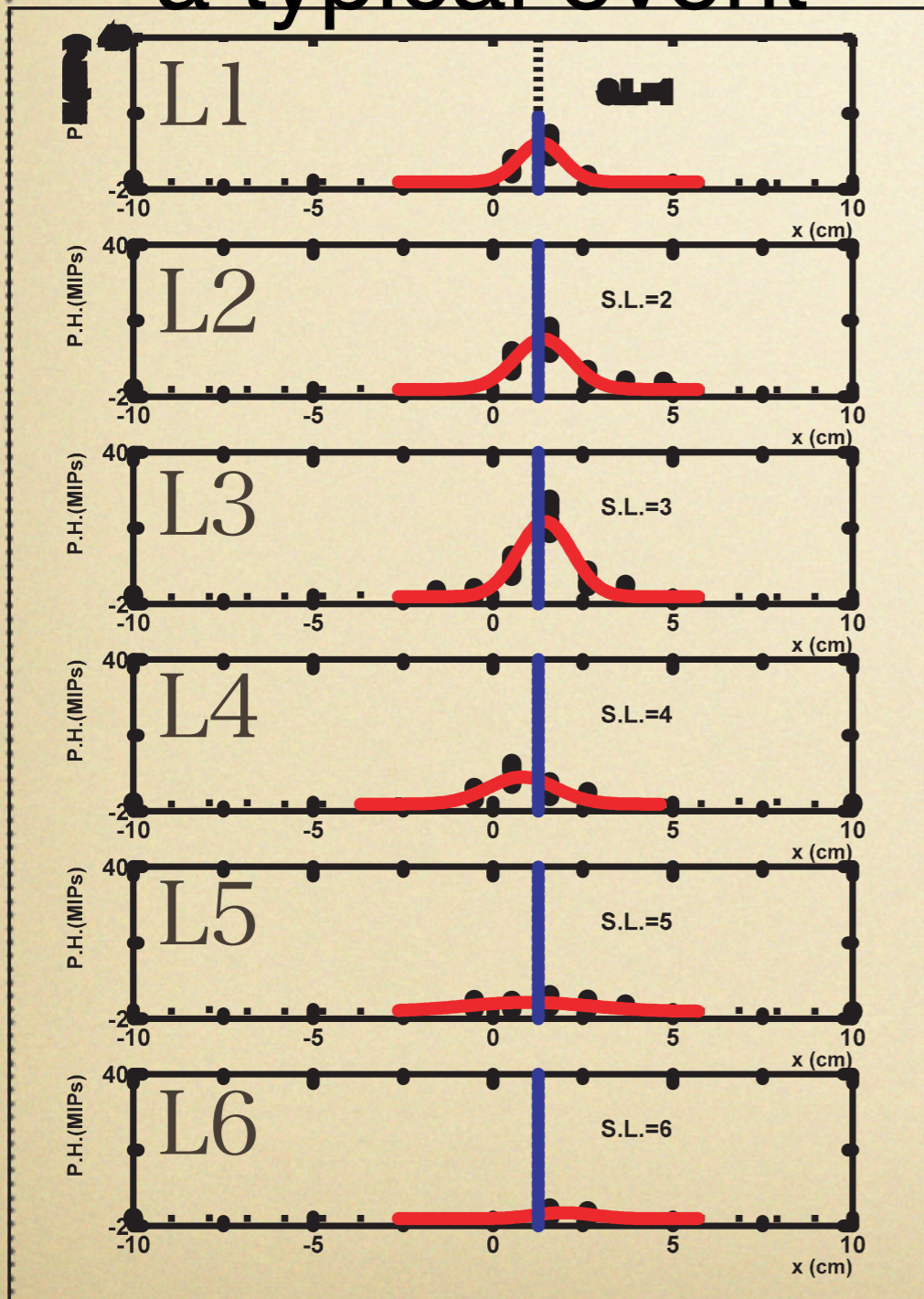

# SSCAL experinice cont.

pictorial detector

Integrated lateral shower profile

4 GeV e,  $\theta=15.9$  degree

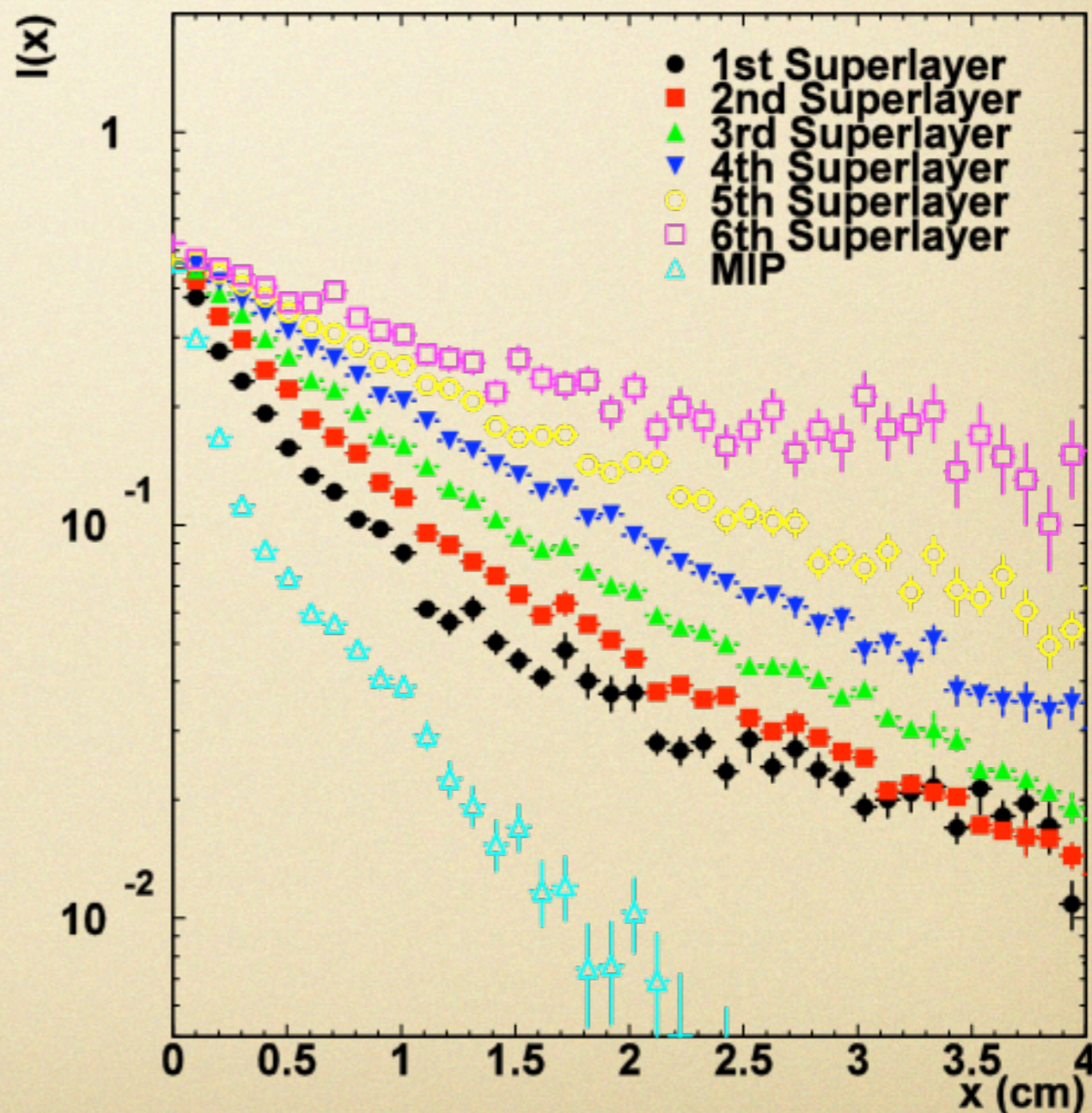
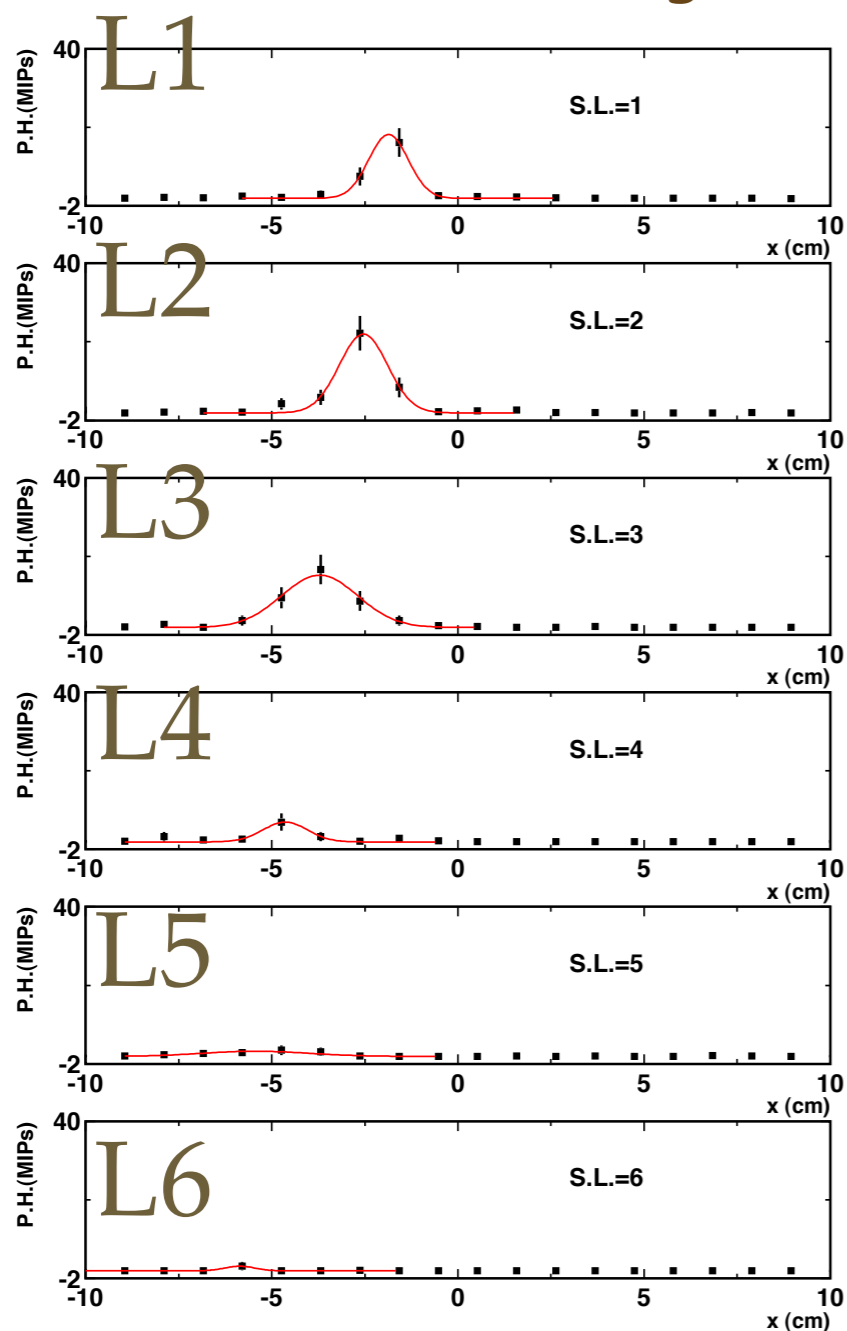

TTCalor06

# scintillator Tile CAL.

## experience

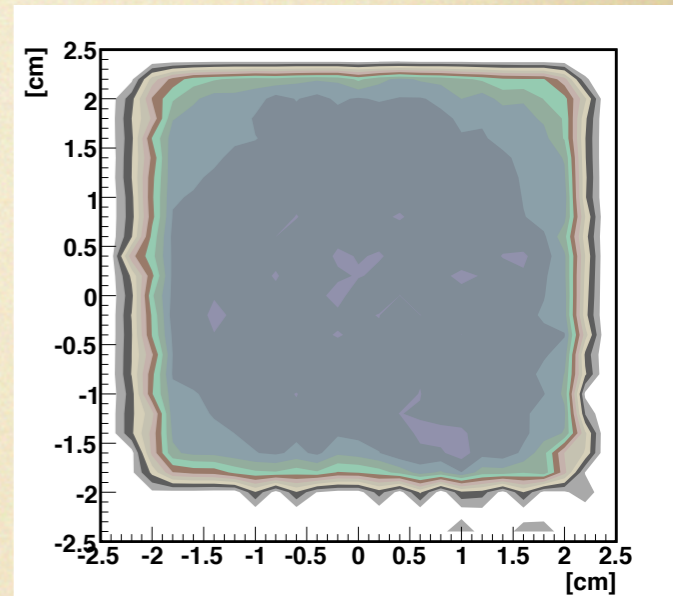
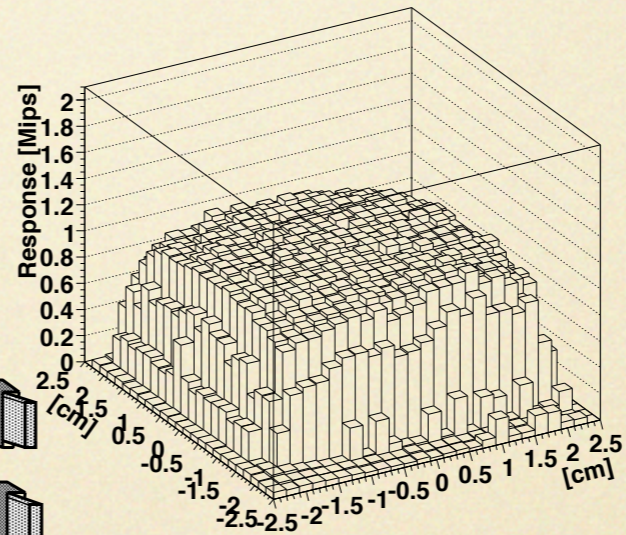
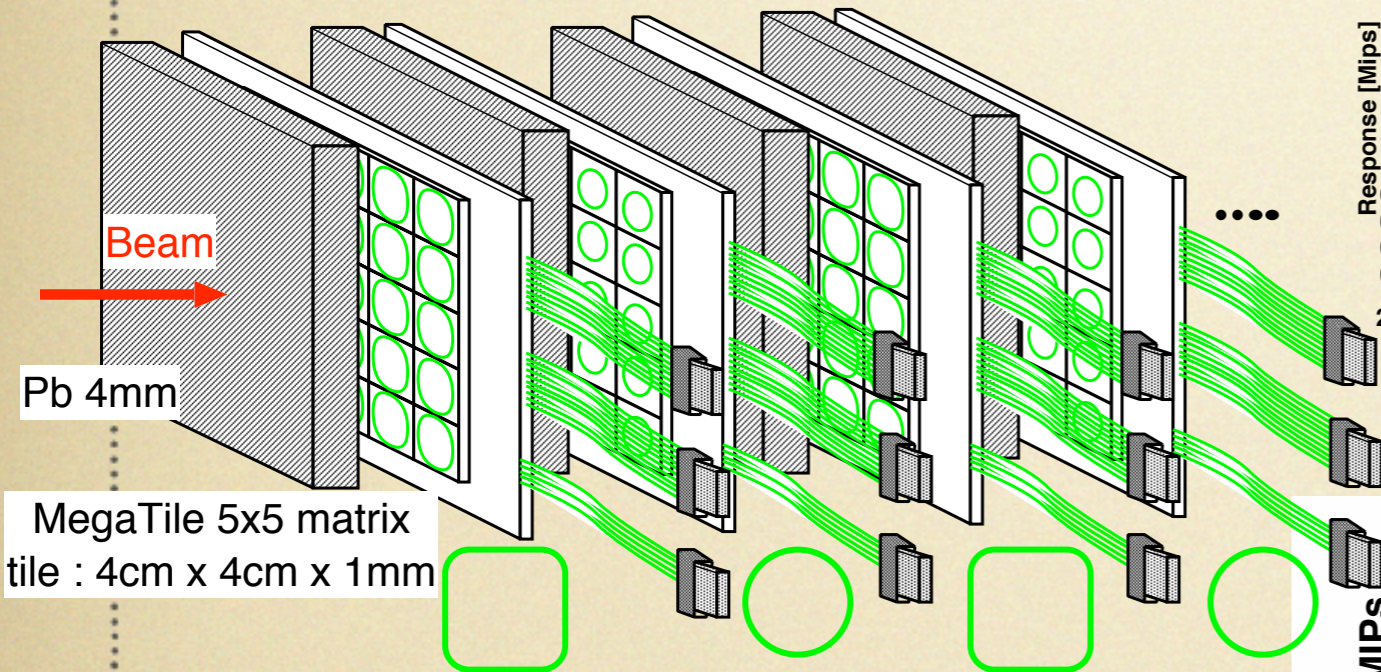

Shower Curve 1GeV to 4GeV

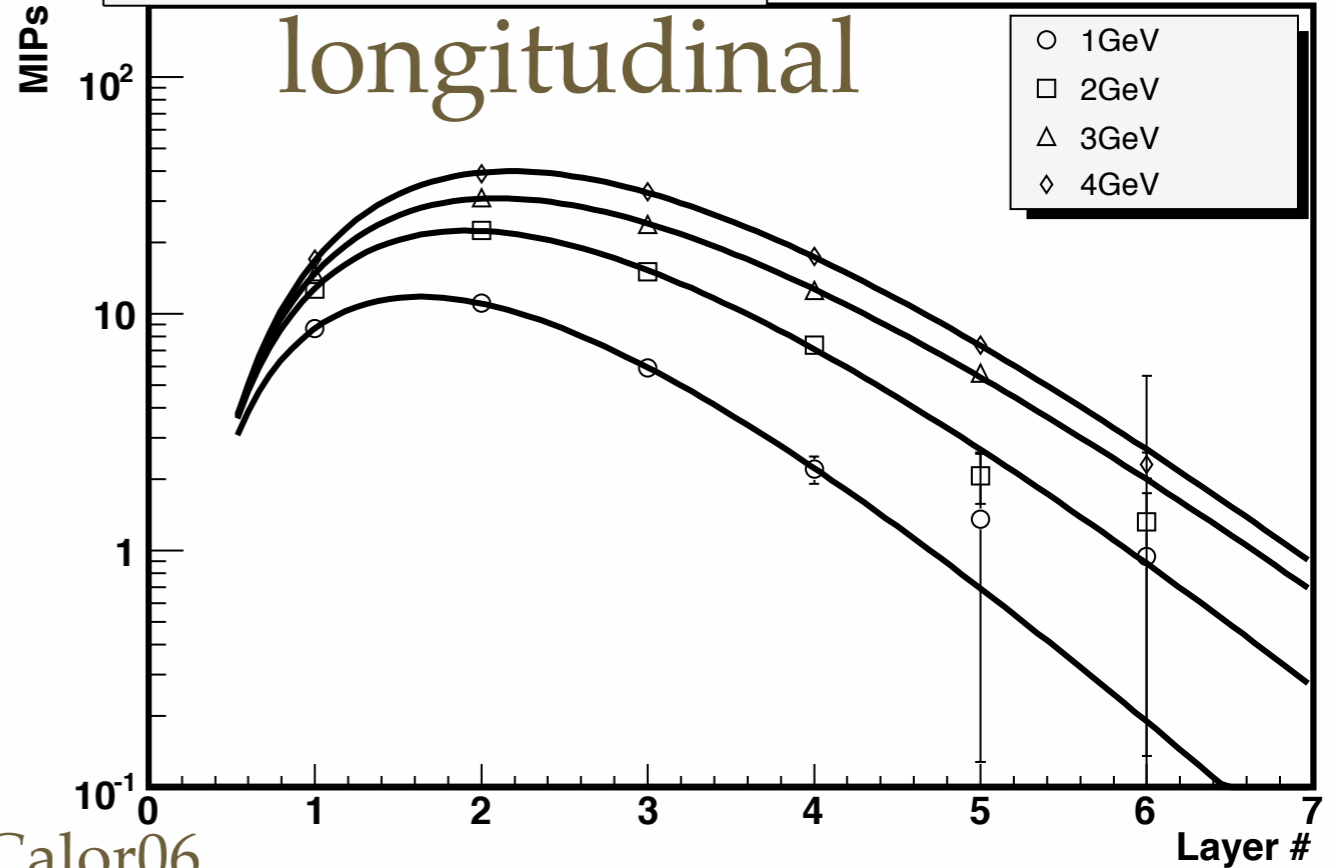

TTCalor06

# Pi-zero

## finding in ECAL

1cm width assumed

finding efficiency \* 10<sup>3</sup>

Y strips

X strips

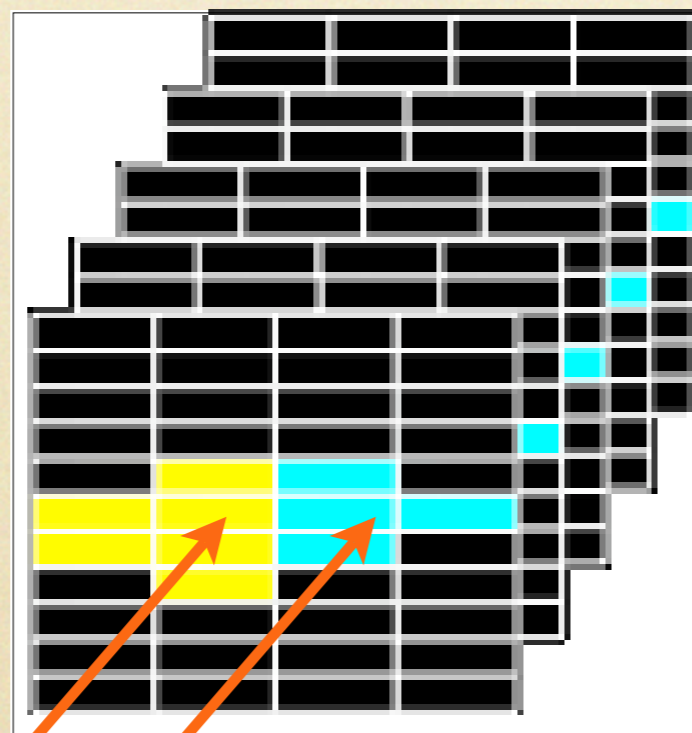
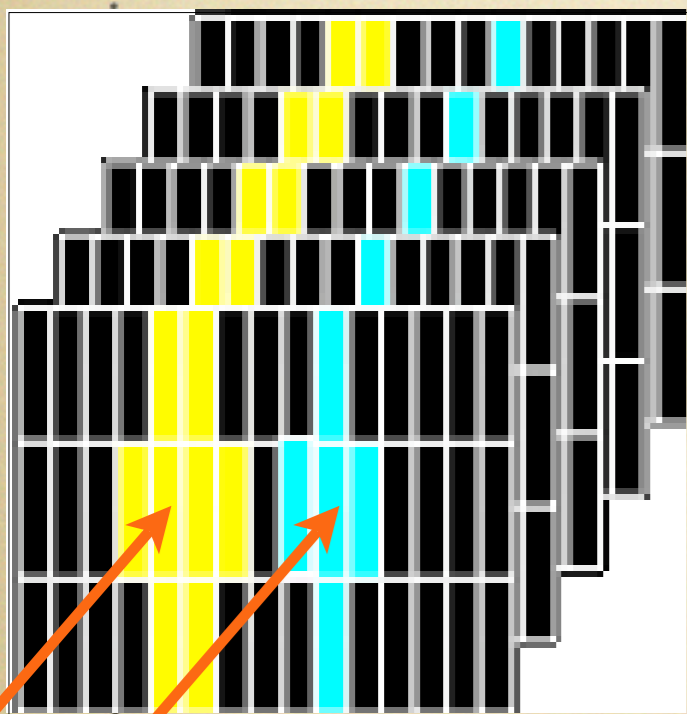

two photons from pizero

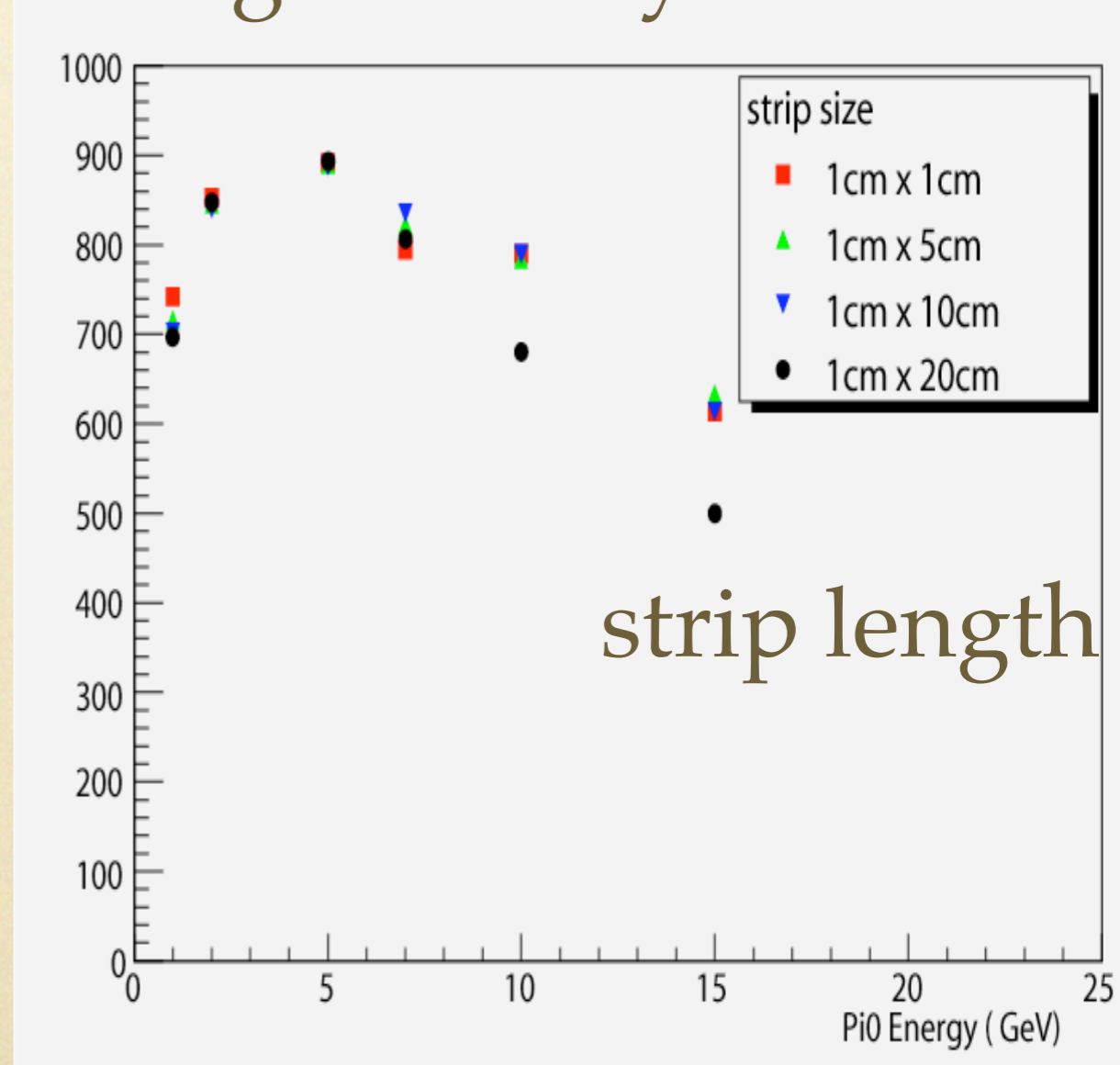

Epi-zero (GeV)

TTCalor06

# scintillator HCAL

## neutron sensitive

timing info.

a pion event  
digitized hits

a pion interaction in HCAL layers

Pb/Sci

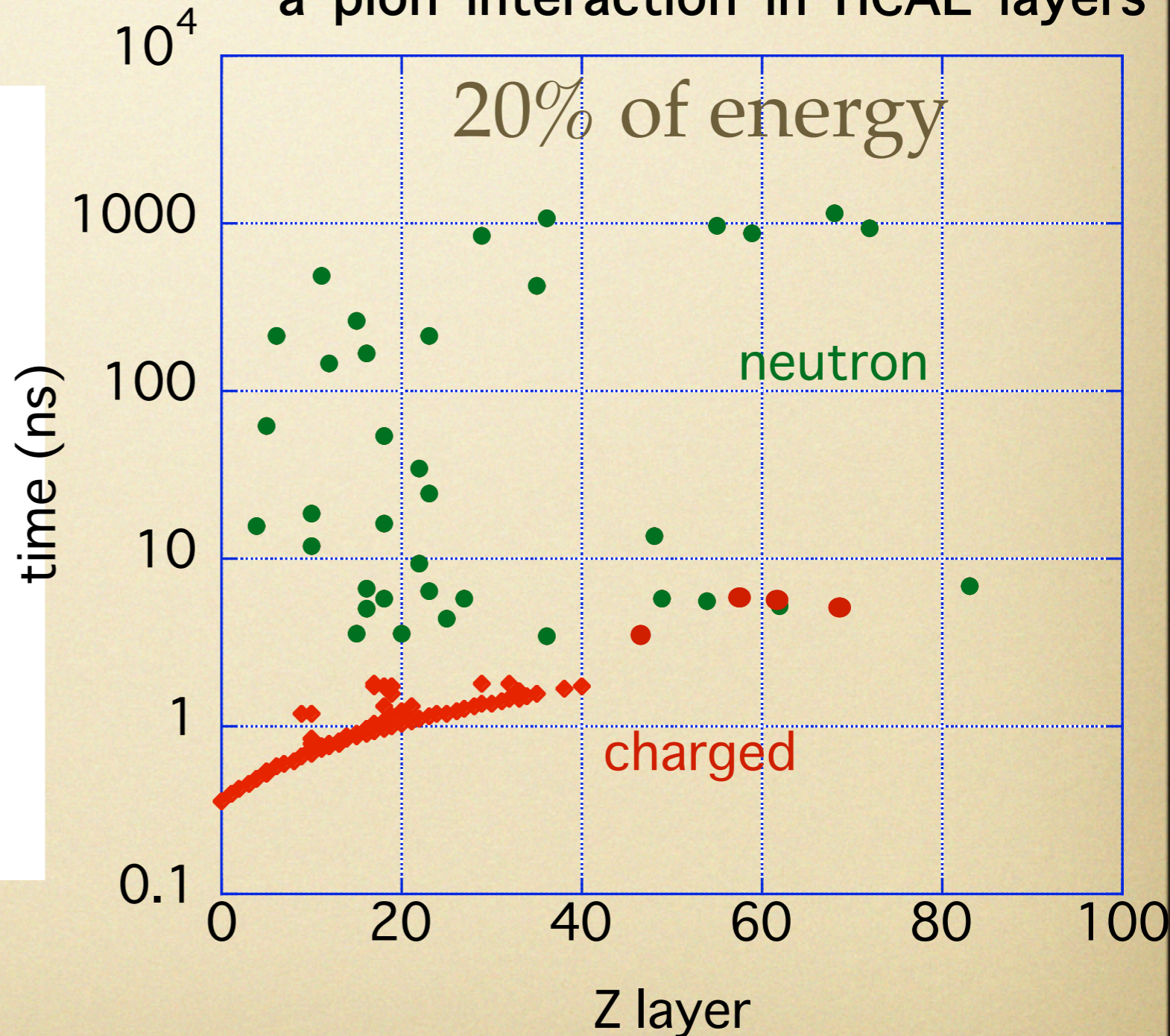
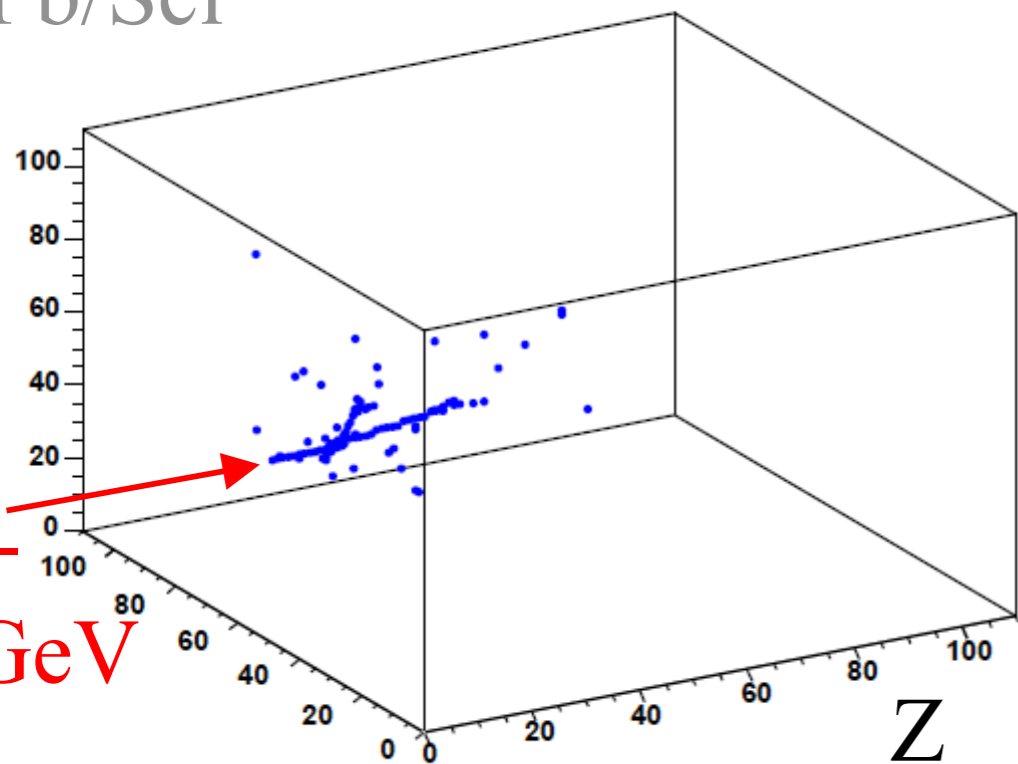

1cm x 1cm  
granularity  
with 8mm lead

# current R&D issues

- Photon sensor (MPPC) and prototype test at beam

MPPC semiconductor pixel photon sensor with Geiger or Limited Geiger Mode

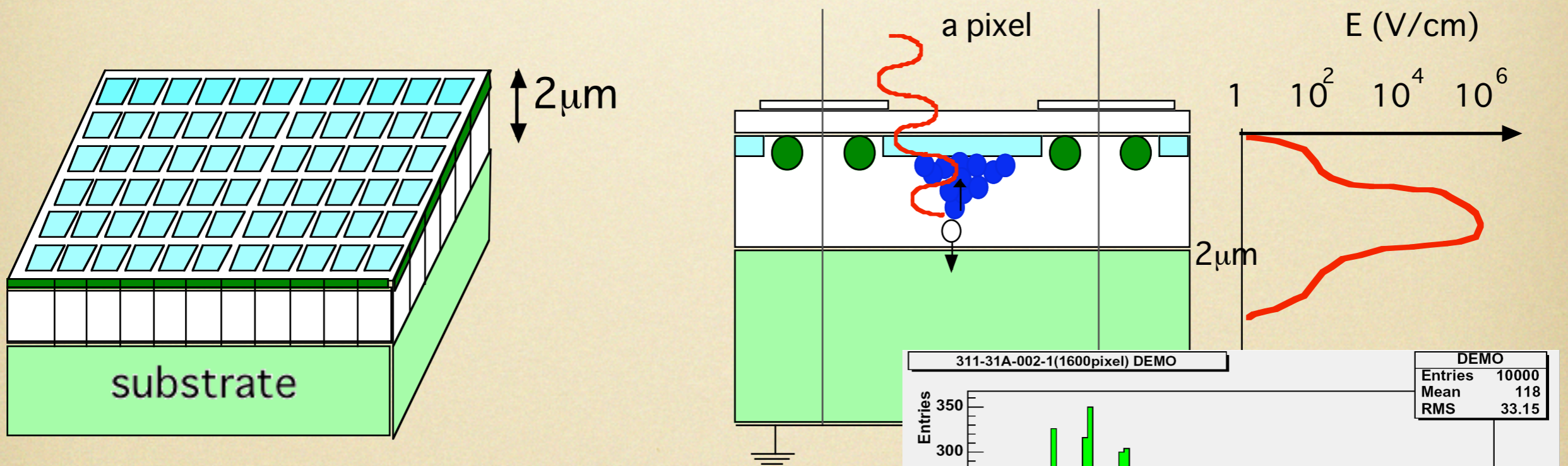

photon counting capability

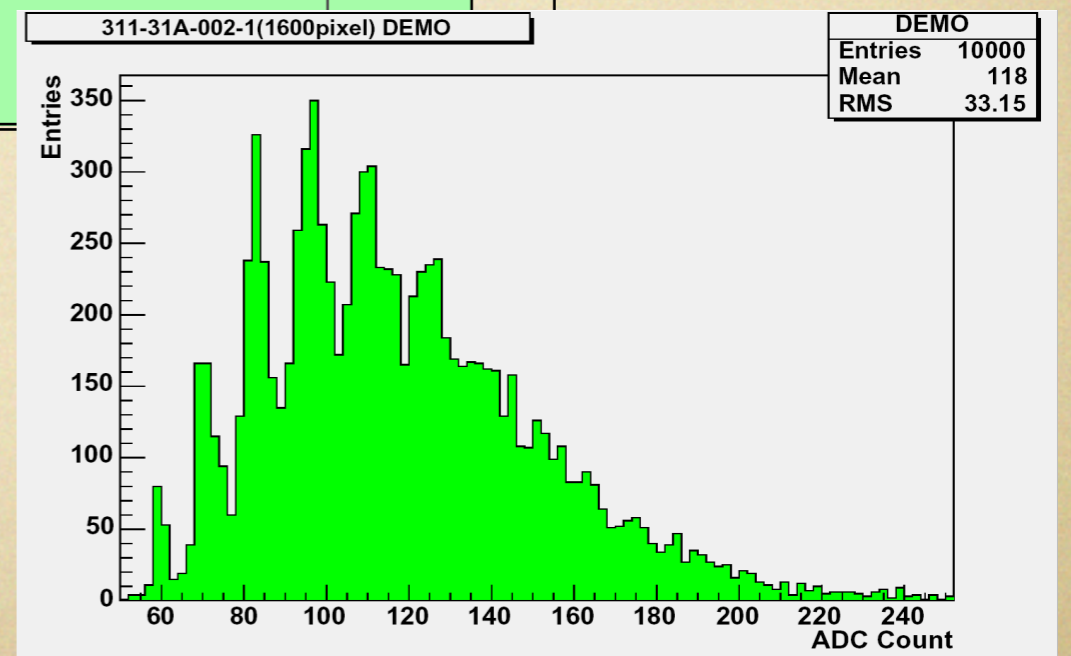



# MPPC (Multi Pixel Photon Counter)

## by HPK

- linearity is important for calorimeter  
however, limited by number of pixels
- fixed to a fiber diameter (~1mm)

number of fired pixels

400pix sample

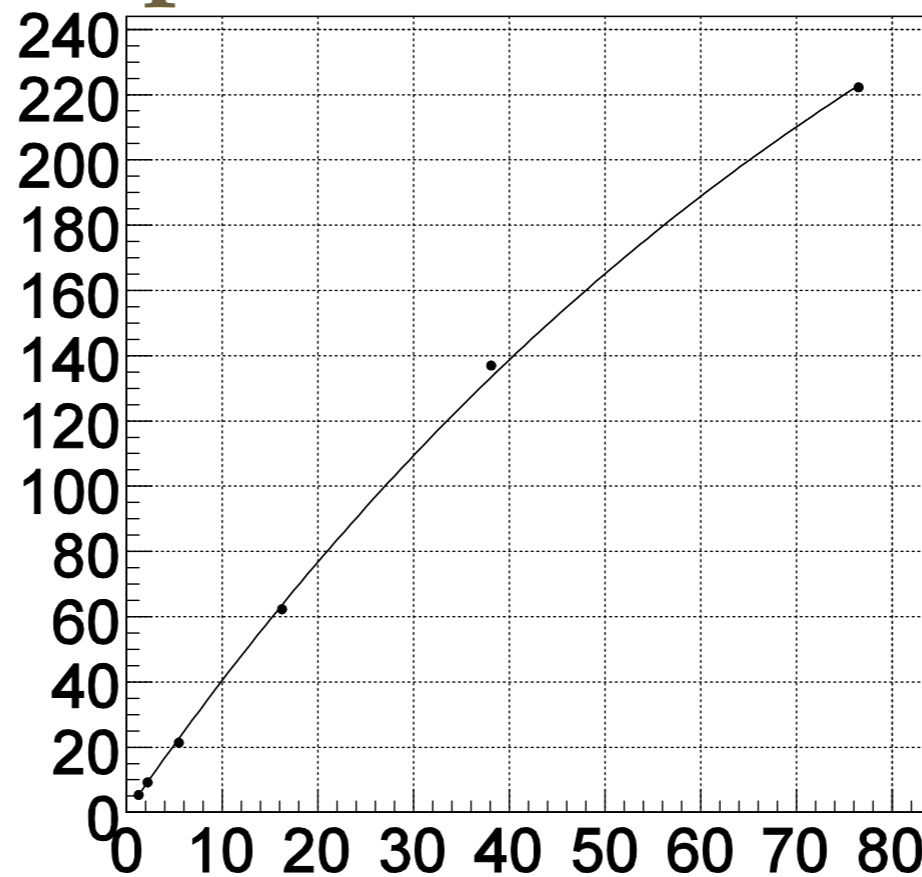

pmt ADC

TTCalor06

# MPPC (HPK)

- pixel test by laser scanner

400 pixel

1600 pixel

gain

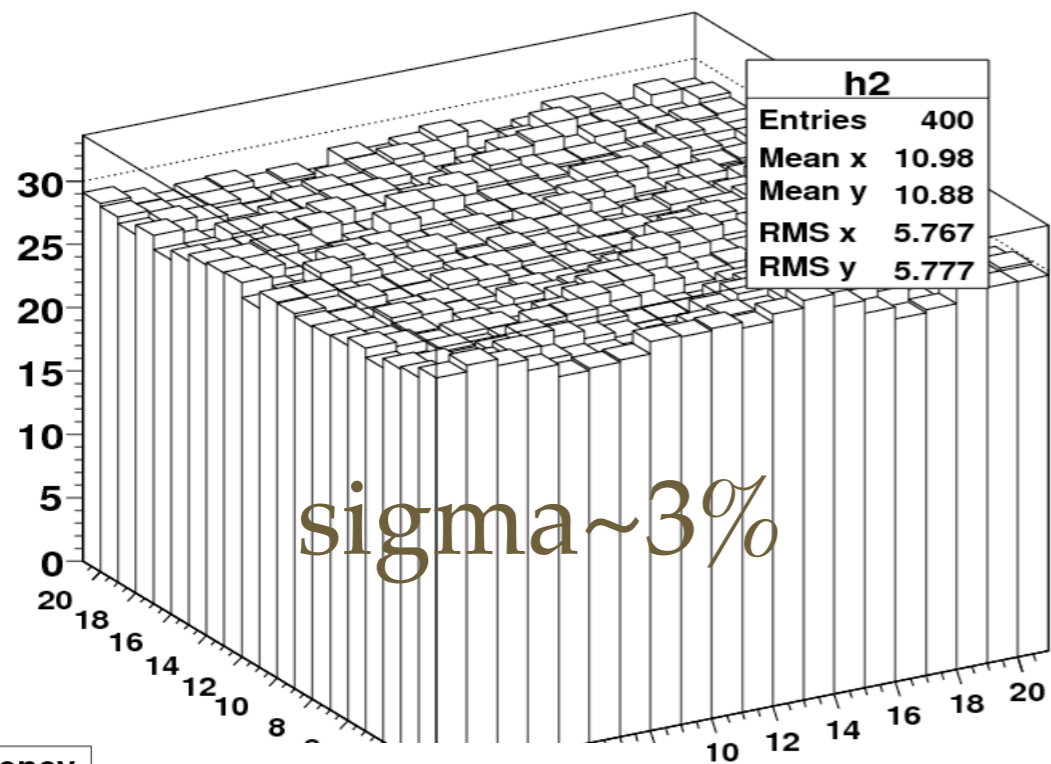

Gain

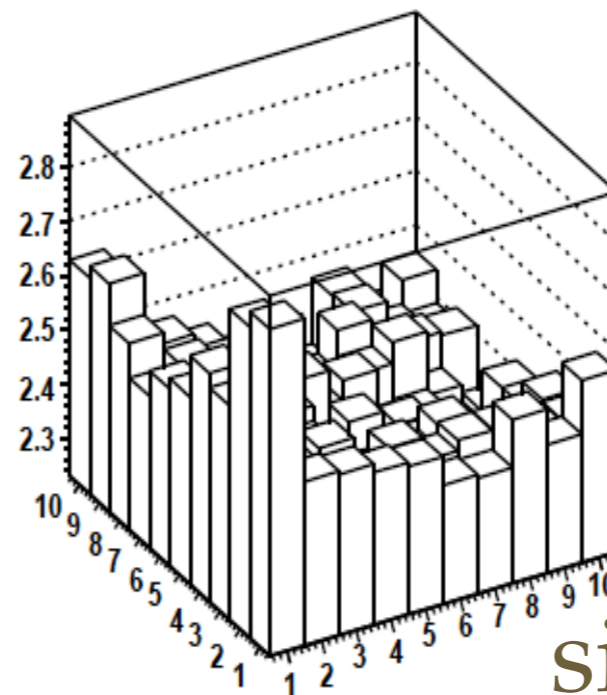

Gain

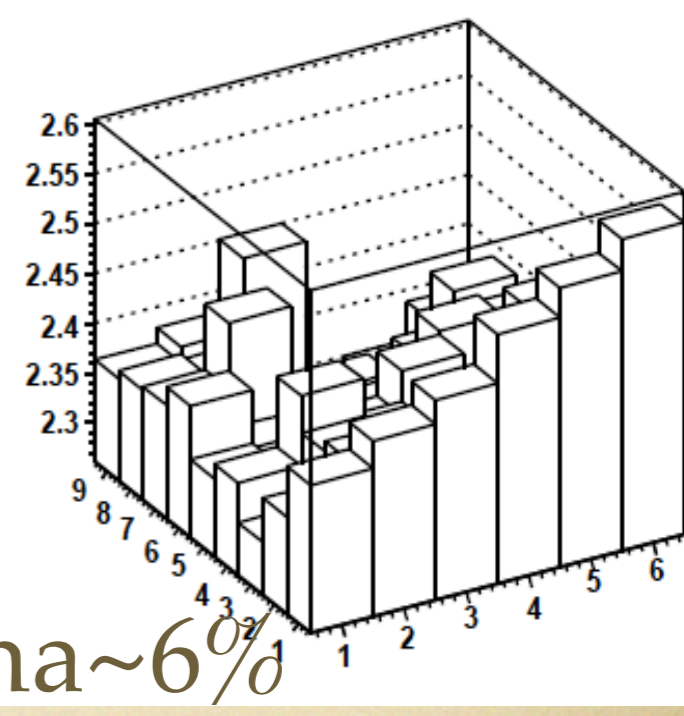

efficiency

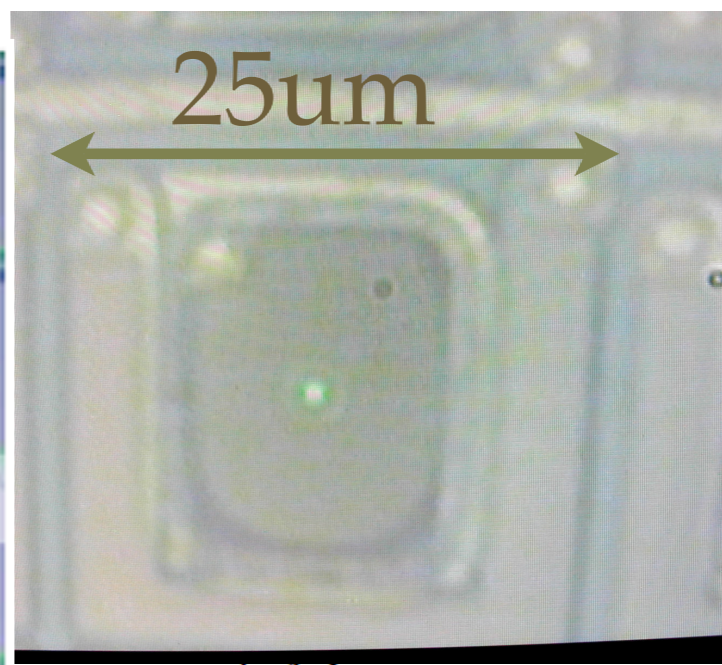
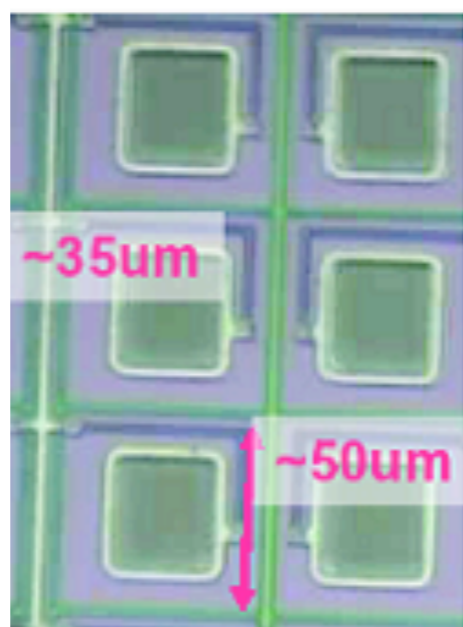
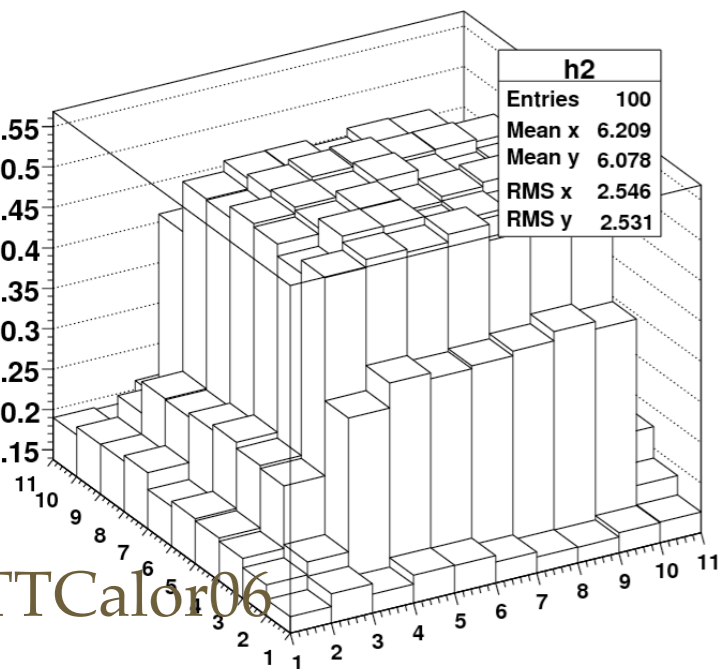

Efficiency

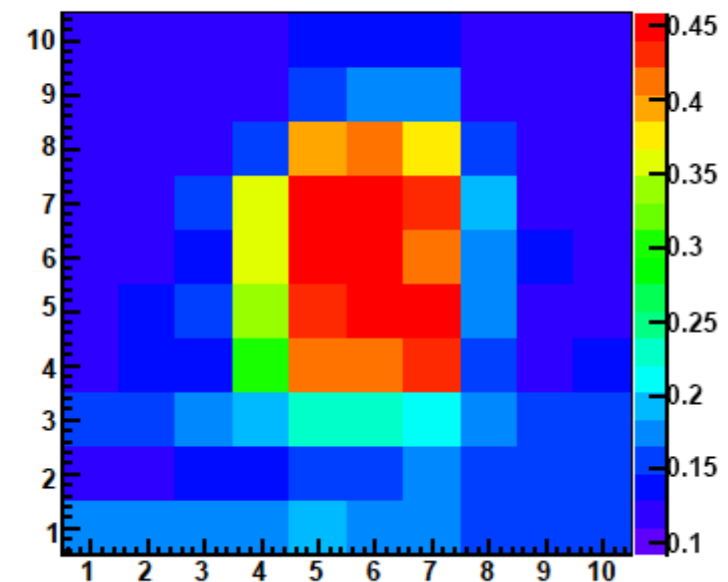

(pitch 50 um)



# prototype HCAL

we will test the prototype at Fermilab 2008

Pb / scintillator sandwich HCAL

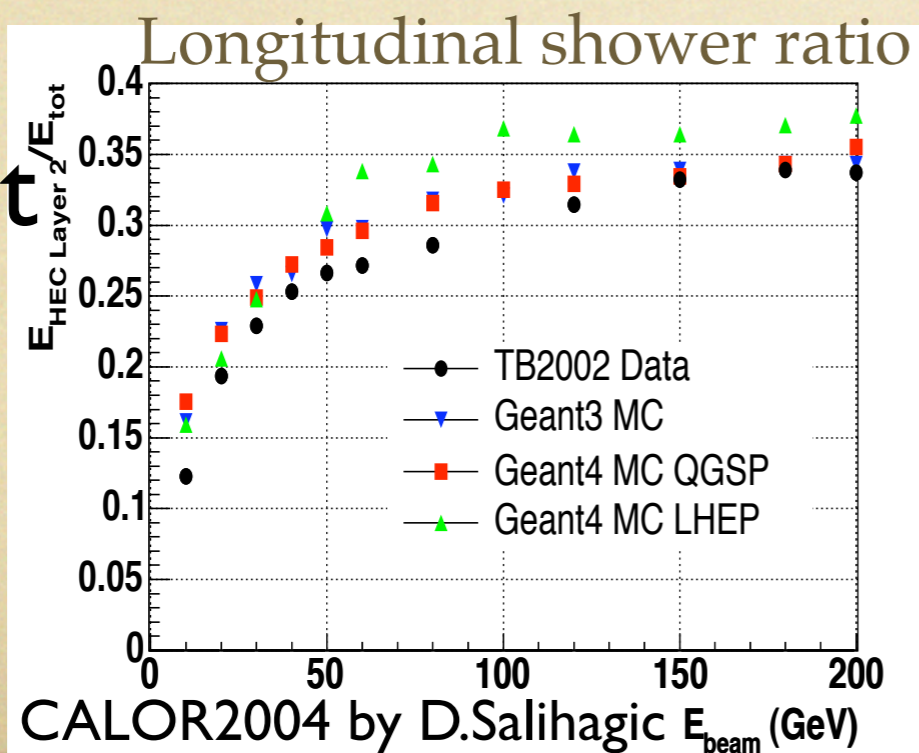
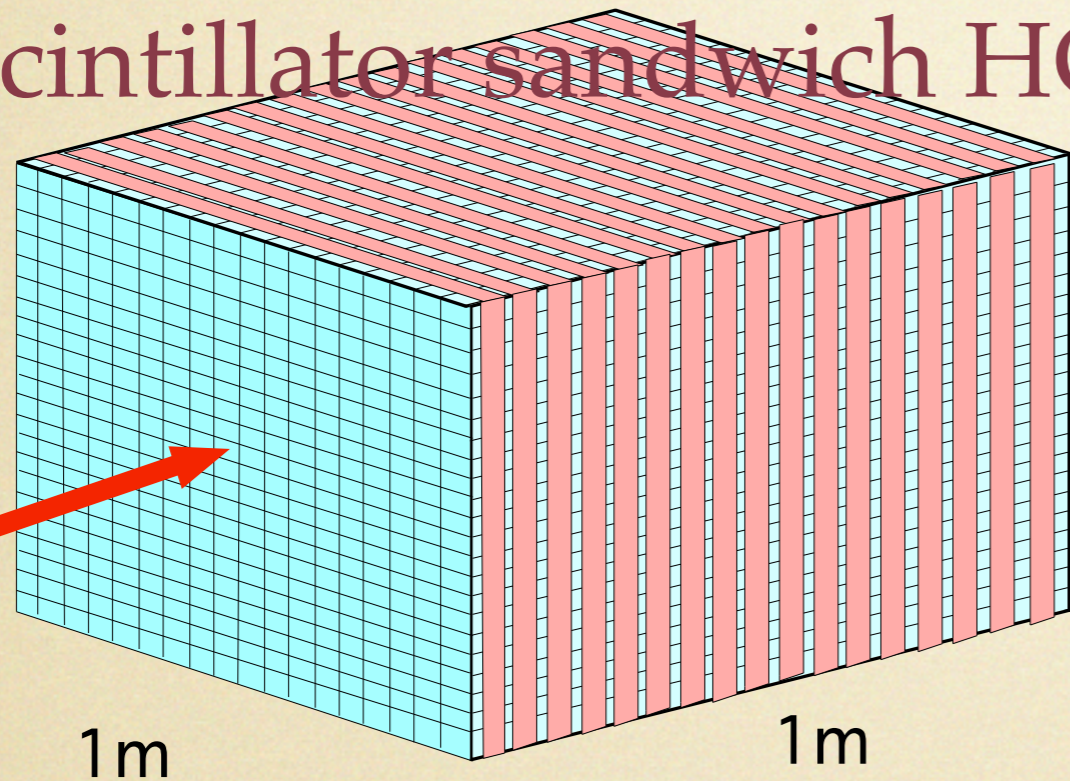

Hadron model dep.  
hadron shower radius

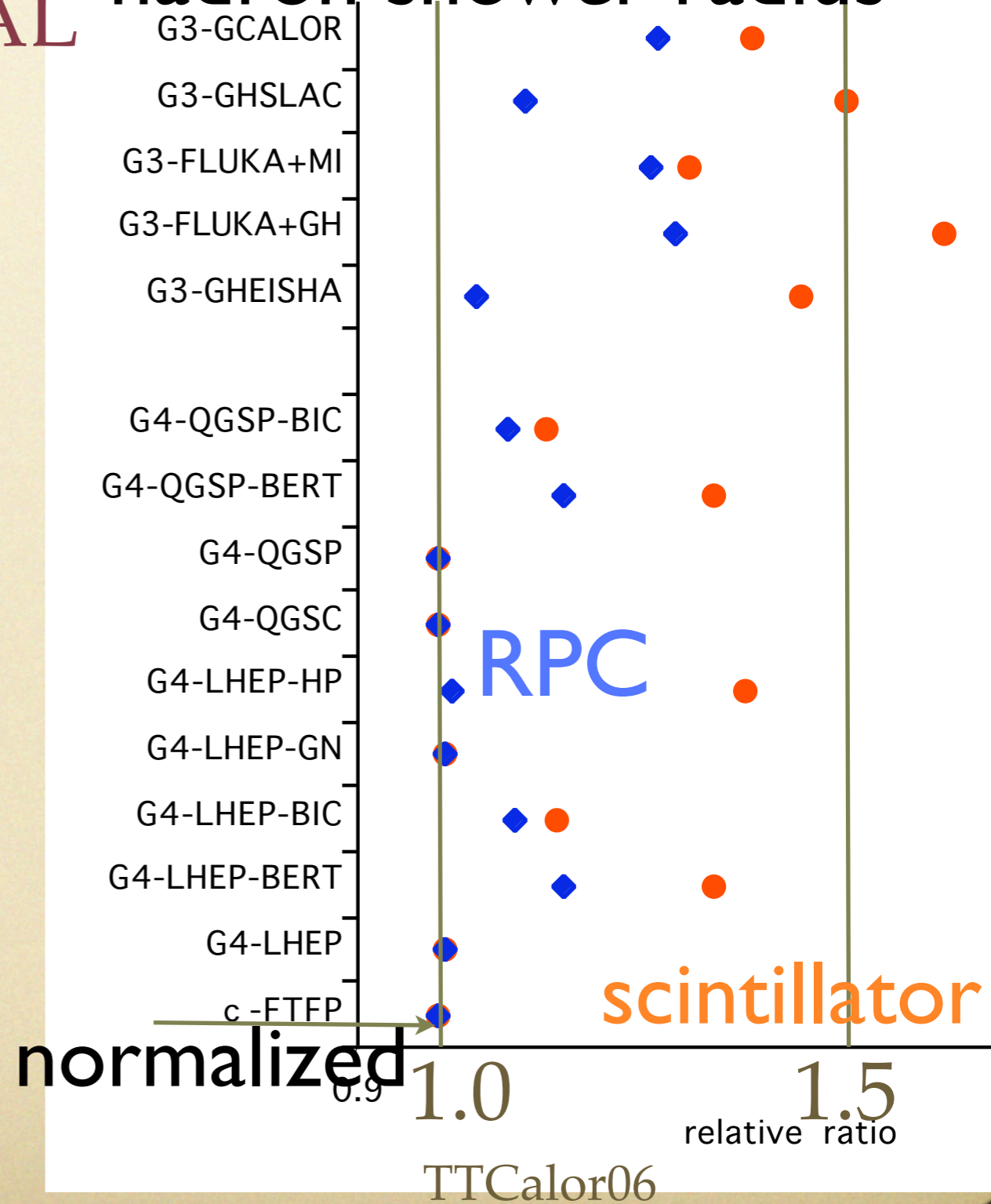

# open issues

- optimization of detector parameters by PF
- strip length/width (ECAL and HCAL)
- electronics development
  - number of channels

# summary and outlook

- **GLD calorimeter**
  - **scintillator based calorimeter**
- **under development**
  - **MPPC & tools (PFA)**
  - **beam test to verify PFA**
- **ILC-CAL**

# backups

- compensation in HCAL
-

# compensation

transverse spread of EM shower

Pb/Sci

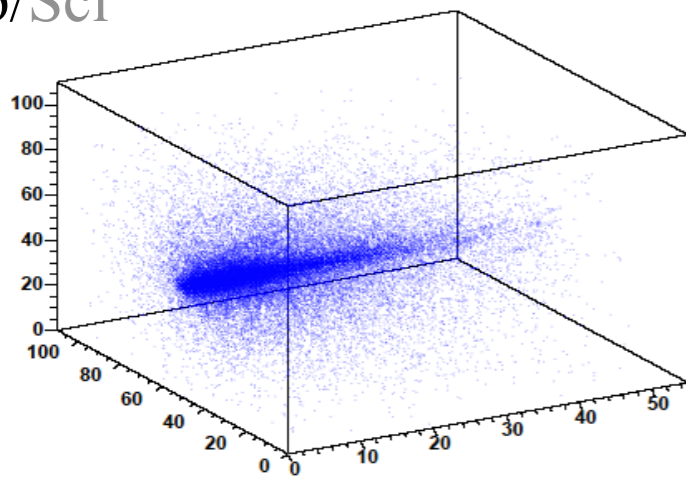

Pb/Sci

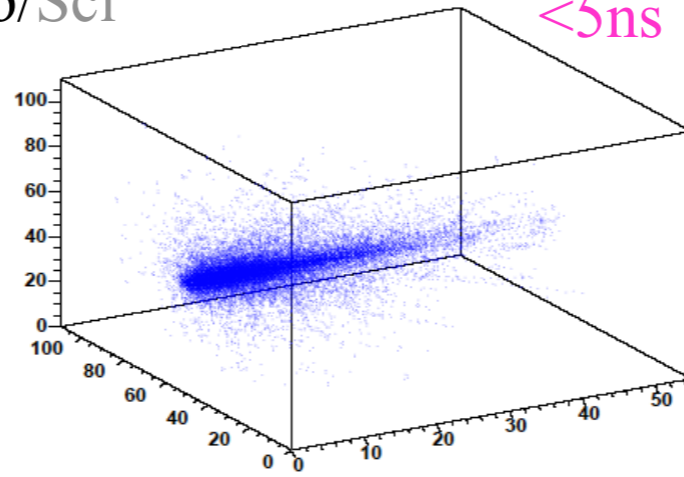

<5ns

Lead 20mm/Sci 5mm 4GeV pi-

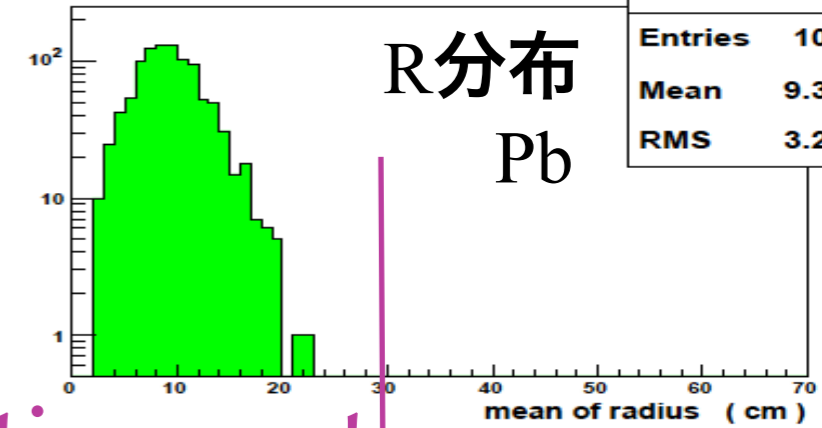

R分布  
Pb

Lead no cut	
Entries	1000
Mean	9.36
RMS	3.22

Fe/Sci

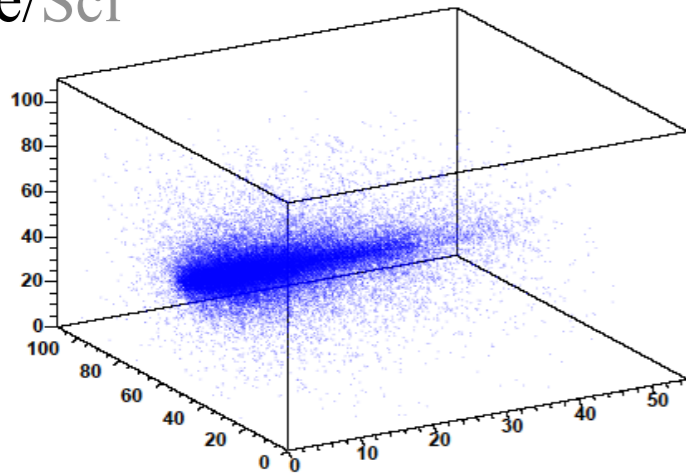

Fe/Sci

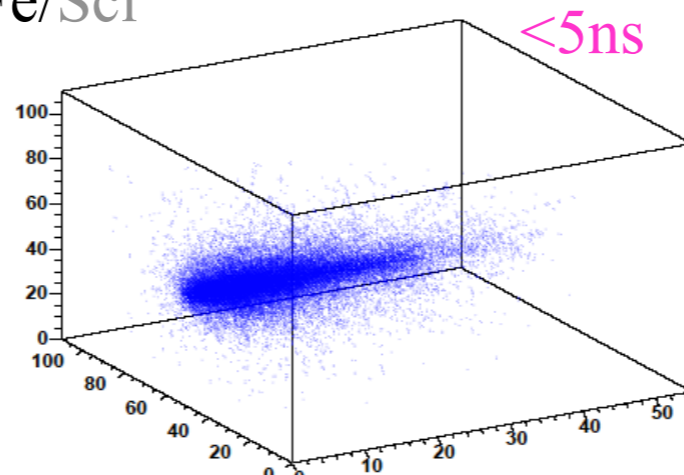

<5ns

Lead 20mm/Sci 5mm 4GeV pi-

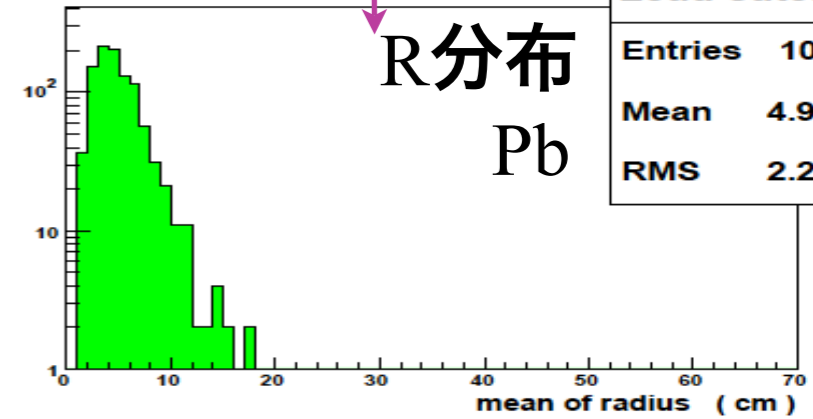

R分布  
Pb

Lead cut5ns	
Entries	1000
Mean	4.90
RMS	2.28

time cut