



# Drive Beam injector frond end developments



- DB injector introduction
- Beam dynamics design
- Hardware design, klystron, buncher, gun
- Conclusions and outlook

# Main activities and goal for 2018

## Design and Implementation studies:

- **Baseline design and staging strategy**
- Solid cost basis and more optimized power/energy (aim for 20% energy reduction)
- Proof of industry basis for key components/units, in particular those specific for CLIC
- Comprehensive reliability/robustness/uptime analysis
- **Pursue increased use of X-band for other machines/applications (hard to set concrete goal)**
- **CDR status: not optimized except at 3 TeV and not adjusted for Higgs discovery, not optimized cost, first power/energy estimates without time for reductions, limited industrial costing, very limited reliability studies**

## System-tests:

- Complete system-tests foreseen for next phase, and comprehensive documentation of the results at CERN (CTF3) and elsewhere
- **Strategy for further system verification before construction (XFEL, connected to light-sources, further drive-beam verifications) or as part of initial machine strategy.**
- **CDR status: CTF3 results initial phase (as of early 2012), ATF and FACET very little, no convincing strategy for further system verification**
- **Demonstrator of drive beam FE and RF power unit based on industrial capacity – will open for larger facilities beyond 2018 if necessary**
- **CDR status: Nothing done beyond CTF3**

## X-band developments:

- Statistics for gradient and structure choice (energy reach) and other X-band elements
- **CDR status: Single elements demonstrated – limited by test-capacity**

## Technology developments:

- Demonstration of critical elements and methods for the machine performance:
  - DR, main linac, BDS with associated instrumentation and correction methods (combination of design, simulation, system-tests and technologies)
  - **Stability/alignment (locally and over distances)**
  - **Module including all parts**
- **CDR status: alignment/stability partly covered, BBA assumed, wakefield mon. perf. assumed, no complete module**



# CLIC Layout at 3 TeV

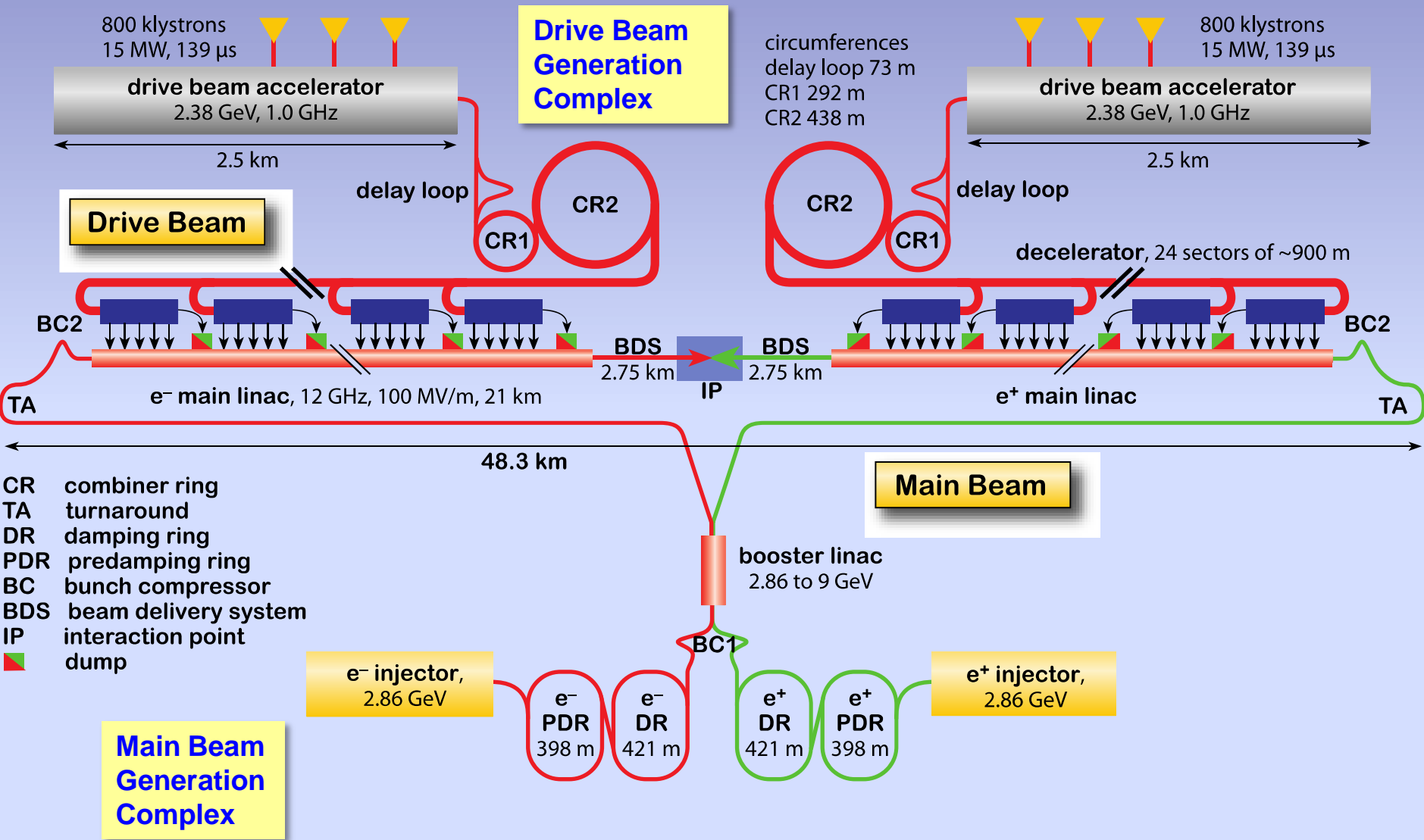



# CLIC DB front end, Post CDR Project

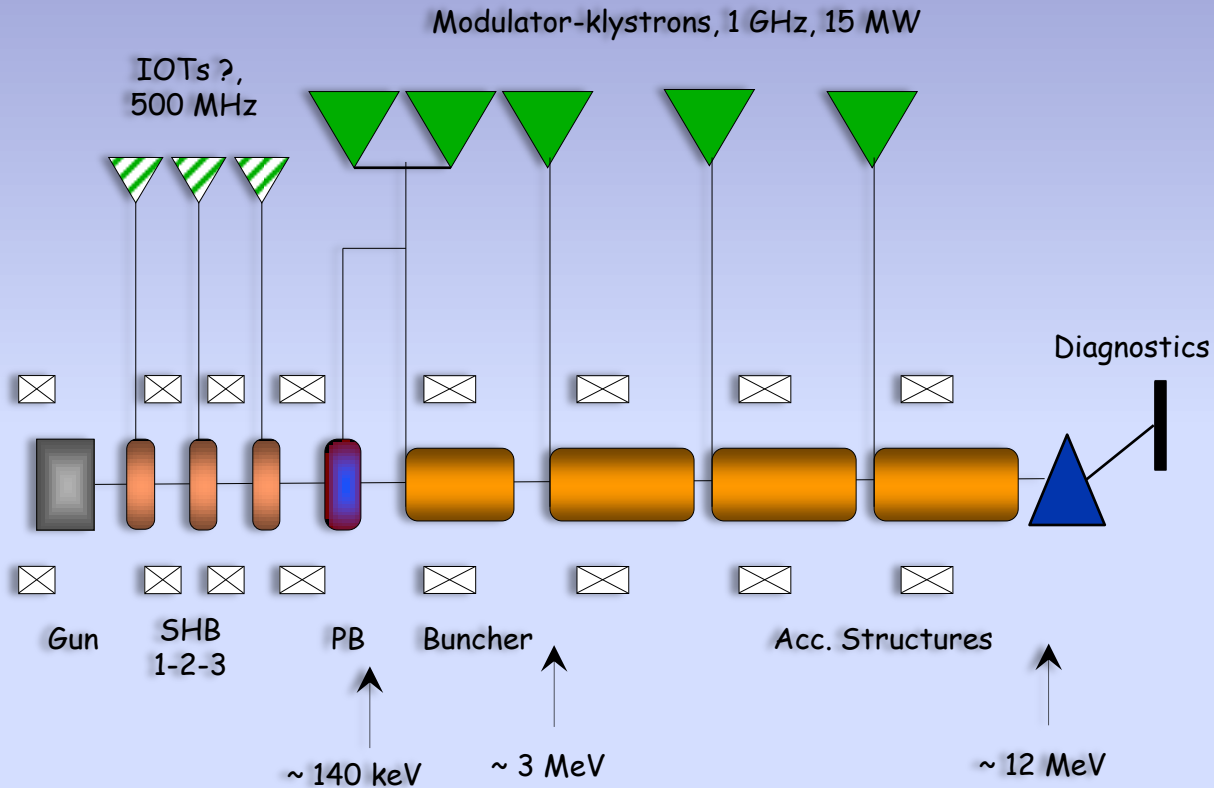

For time being only major component development:  
GUN, SHB, high bandwidth 500 MHz source, 1 GHz MBK, modulator  
and fully loaded accelerating structure



# CLIC DB injector specifications



Parameter	Nominal value	Unit
Beam Energy	50	MeV
Pulse Length	<b>140.3</b> / 243.7	$\mu\text{s}$ / ns
Beam current	4.2	A
Bunch charge	<b>8.4</b>	nC
Number of bunches	70128	
Total charge per pulse	<b>590</b>	$\mu\text{C}$
Bunch spacing	<b>1.992</b>	ns
Emittance at 50 MeV	100	mm mrad
Repetition rate	100	Hz
Energy spread at 50 MeV	1	% FWHM
Bunch length at 50 MeV	3	mm rms
Charge variation shot to shot	<b>0.1</b>	%
Charge flatness on flat top	<b>0.1</b>	%
Allowed satellite charge	< 7	%
Allowed switching time	5	ns



# Sub Harmonic Bunchers (SHBs)



Modulator-klystrons, 1 GHz, 15 MW

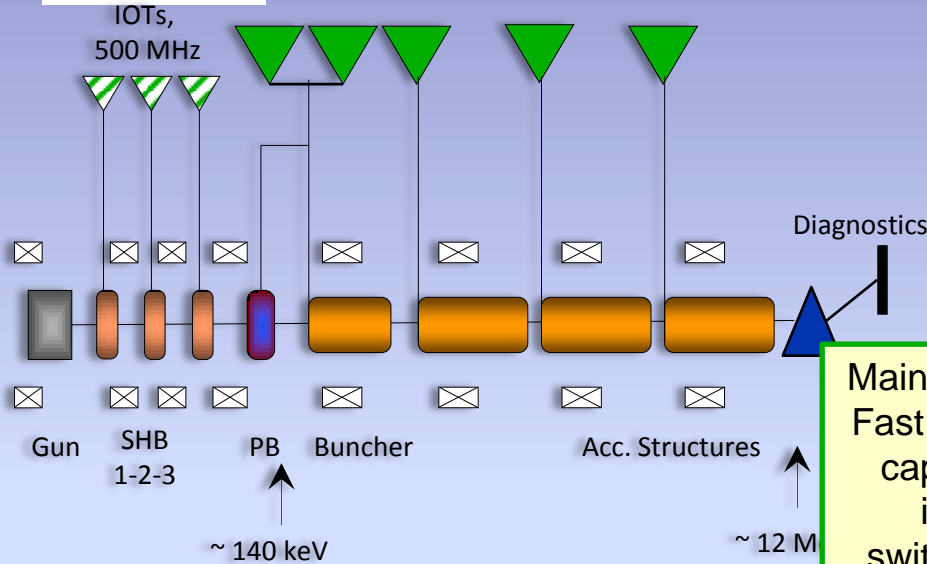

Main challenge of SHBs:  
Fast 180° phase flipping  
capability, simulation  
indicate < 18 ns  
switching time needed

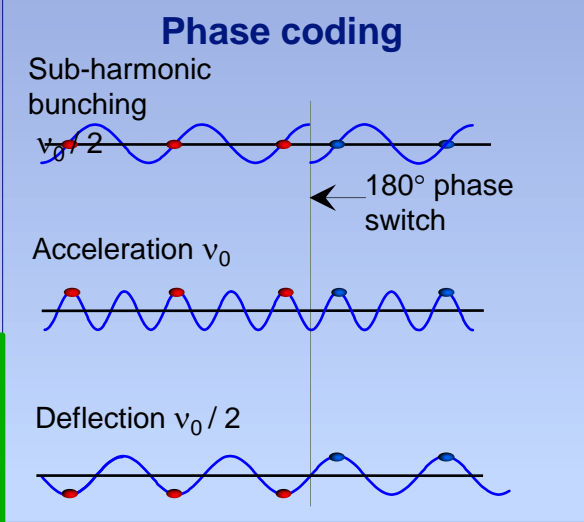

### Drive beam time structure - initial

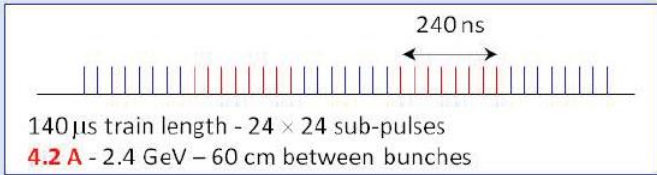

### Drive beam time structure - final

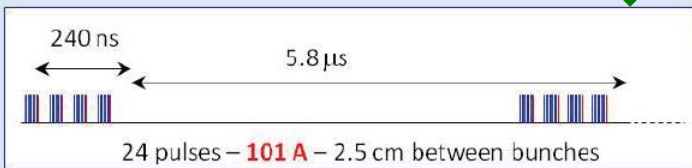

### Gap creation and combination

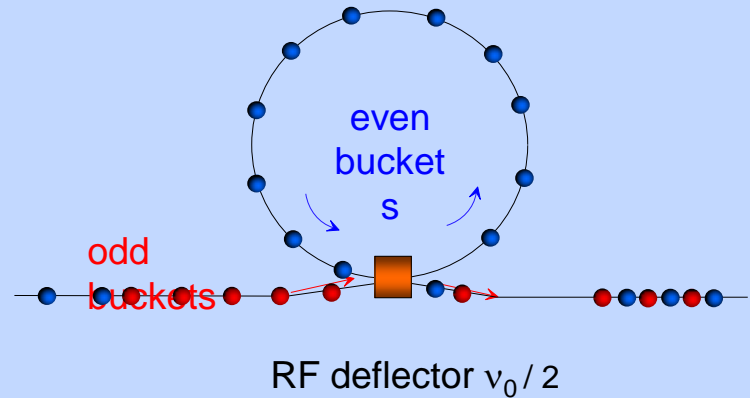

# CLIC drive beam injector layout

SOLENOIDS

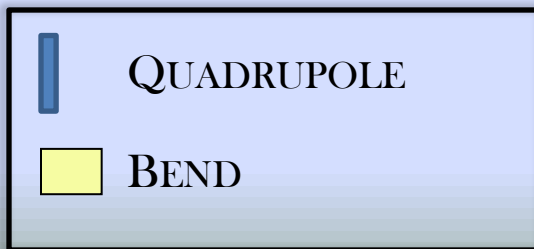
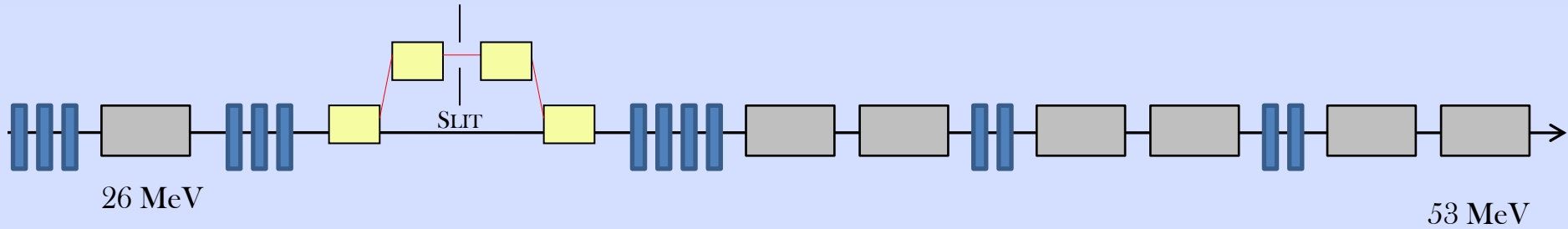
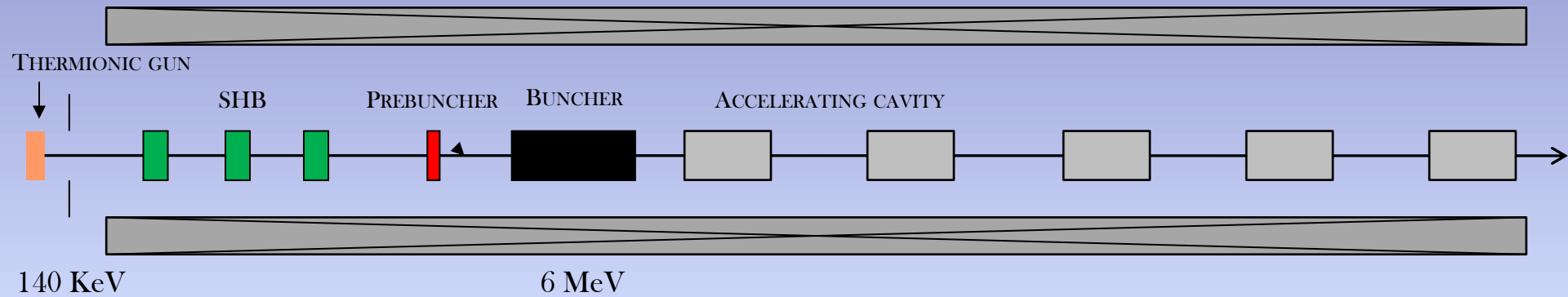

# DB injector optimization

## Optimization of the SHB system

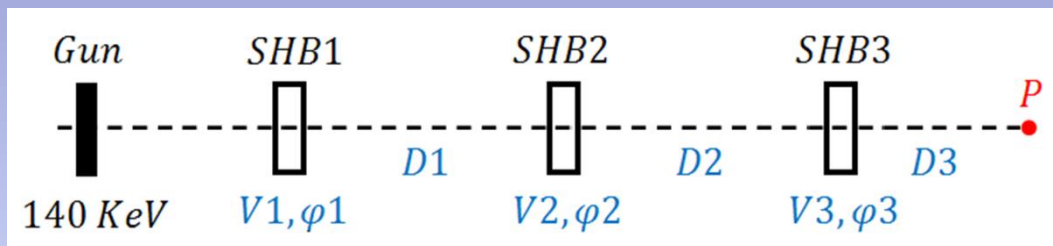

SHB	V (kV)	D (cm)	Satellite (%)
1	15	220	25.8
2	30	95	10.6
3	45	50	3.9

Particle population in [-60, 60]: 93.3%

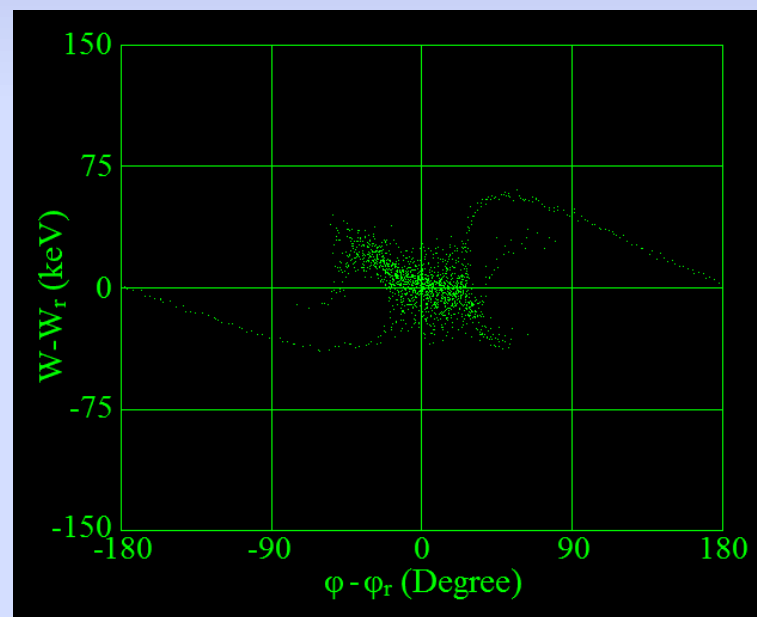

Additional 1 GHz pre-buncher for further optimization



# DB injector optimization

## Optimization of the TW buncher structure

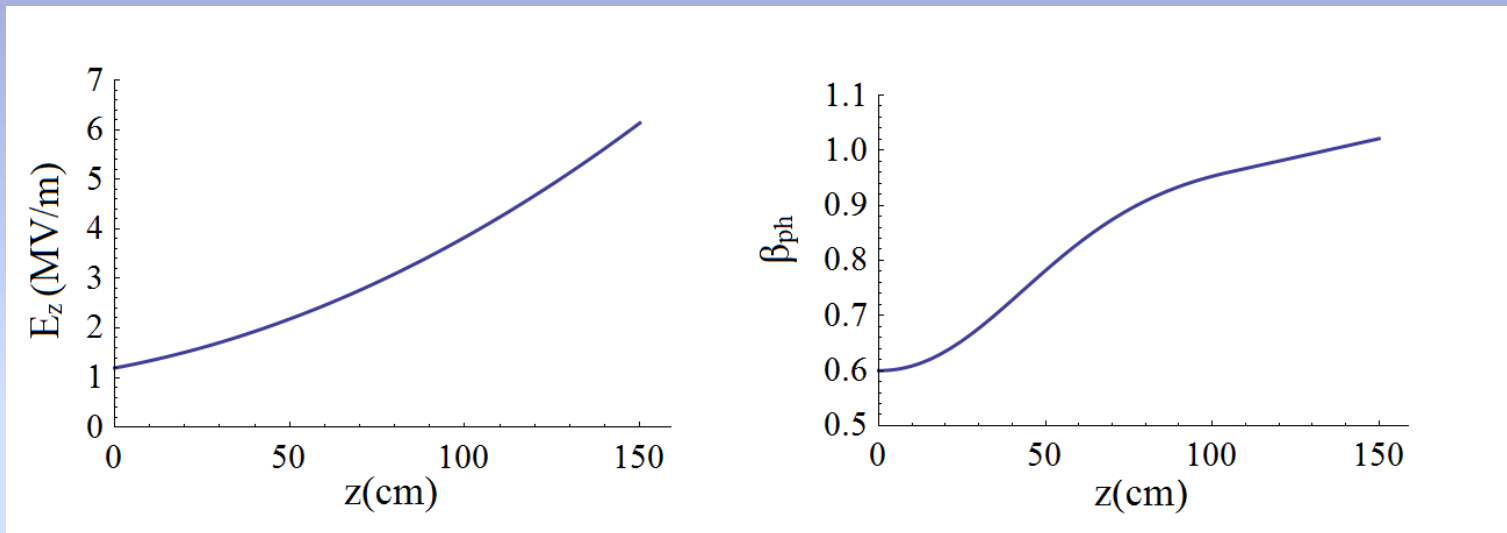

Parameter	Value
$E_{min}(MV/m)$	1.23
$E_{max}(MV/m)$	5.72
L(cm)	147
P(MW)	~20

# DB injector optimization

phase space after TW buncher

Final phase space at 50 MeV

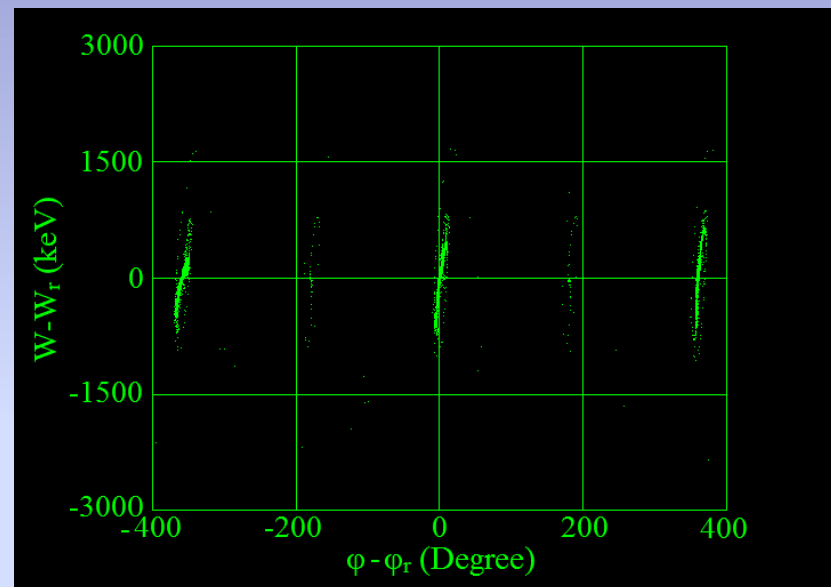
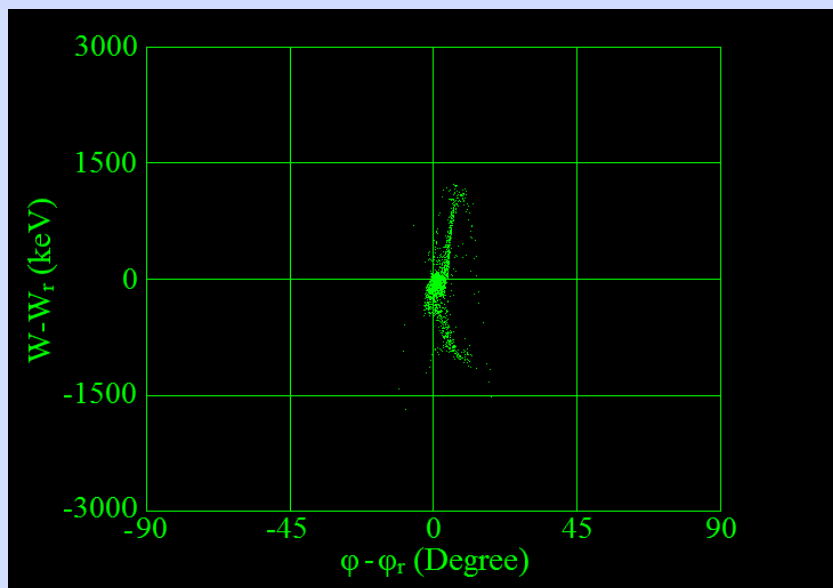

Parameter	Value
$\sigma_L$ (mm)	2.64
$\sigma_W$ (MeV)	0.480
$W_{av}$ (MeV)	50.0
Satellite (%)	2.2

# Tentative klystron

Thales



Toshiba



CPI #a



CPI #b



# Tentative klystron parameters



Recommended parameters of the L-band klystron for CLIC

Parameter	
Frequency, GHz	1.0
N beams	6
Cathode diam., cm	4.94
Cathode loading A/cm <sup>2</sup>	1.76-1.96
$\mu$ -perveance/beam	0.45
Peak power (max), MW	20-25
Cathode Voltage, kV	160 - 180
Cathode current, A	180-202
Efficiency, %	>70

Estimations from Igor Syrathev

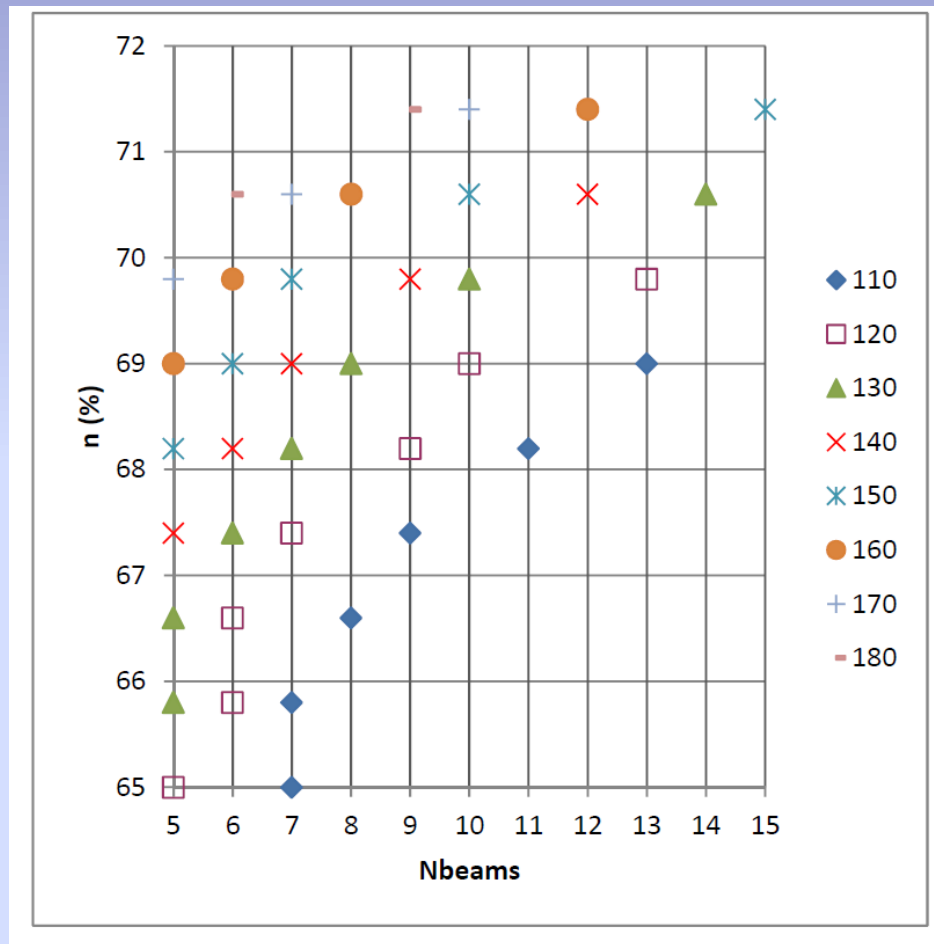

Efficiency for 20 MW for different voltages (Thales study)

# Modulator design

## – Main modulator specifications

Average power of 200kW per modulator R

Reproducibility of the peak pulse amplitude is **about  $10^{-5}$**  (frequency range between 6 kHz and 4 MHz).

At lower frequencies, feedbacks compensates

Higher frequencies are naturally filtered by the machine

**Modulator main specifications**

Pulse voltage	$V_{kn}$	150	kV
Pulse current	$I_{kn}$	160	A
Peak power	$P_{out}$	24	MW
Overall efficiency	$Eff_{glob.}$	>90	%
<b>Rise &amp; fall times</b>	$t_{rise}$	<b>3</b>	<b><math>\mu</math>s</b>
Flat-top lenght	$t_{flat}$	140	$\mu$ s
Repetition rate	$Rep_r$	50	Hz
Flat-top stability	FTS	0.85	%
<b>Pulse repeatability</b>	<b>PPR</b>	<b>10-100</b>	<b>ppm</b>

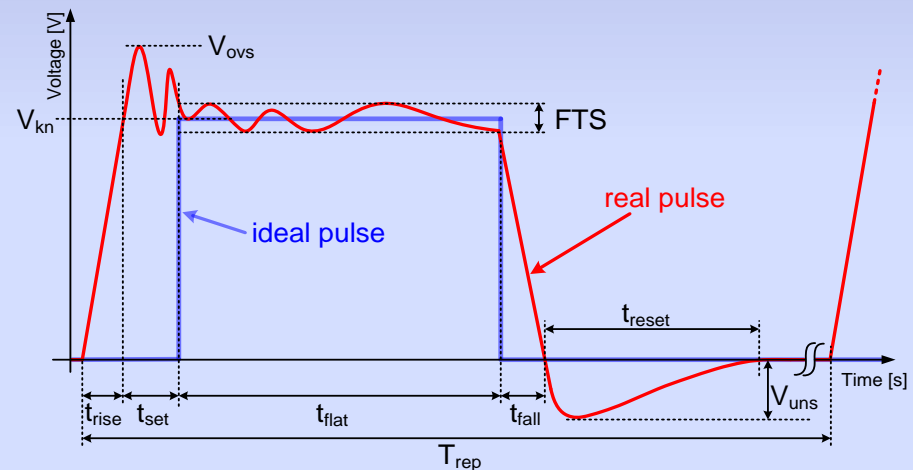

- Low AC power fluctuation
- High reliability / availability

# R&D strategy and status

## – General concept

1. At CERN we study common issues to all R&D partners
2. Tasks allocation considering partner expertise
3. Obtain 2 topologically different solutions ( $V_{AC}$  not defined)

Low voltage configuration

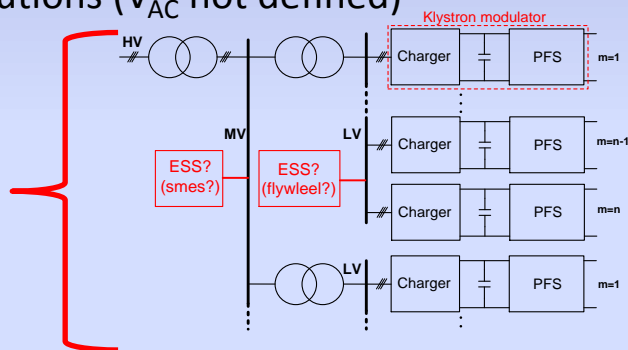

High voltage configuration

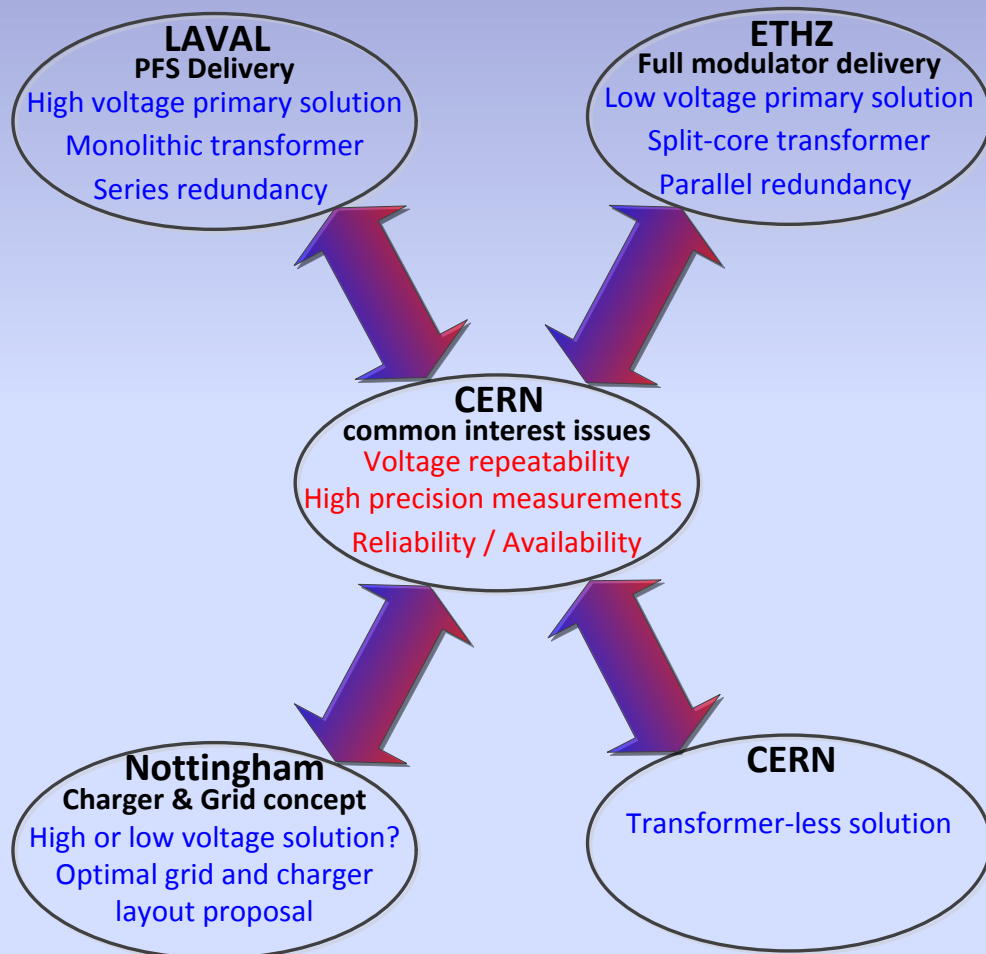
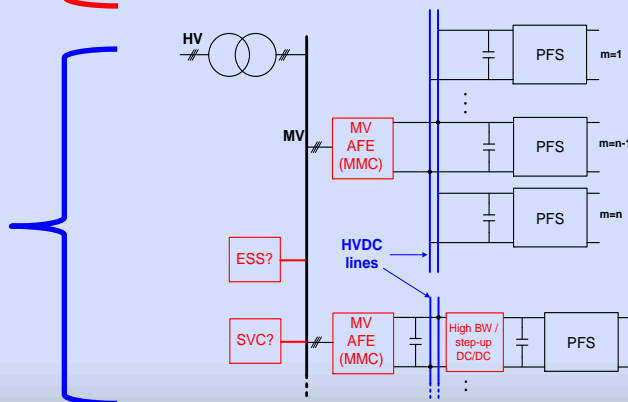

# R&D strategy and status

- ETH: Topology defined-matrix transformer based

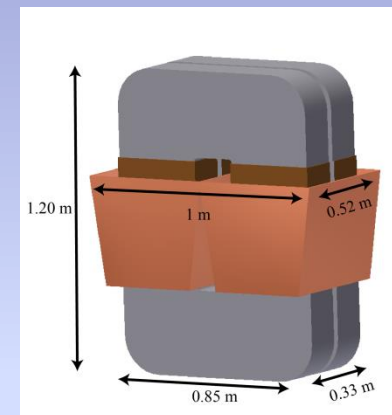
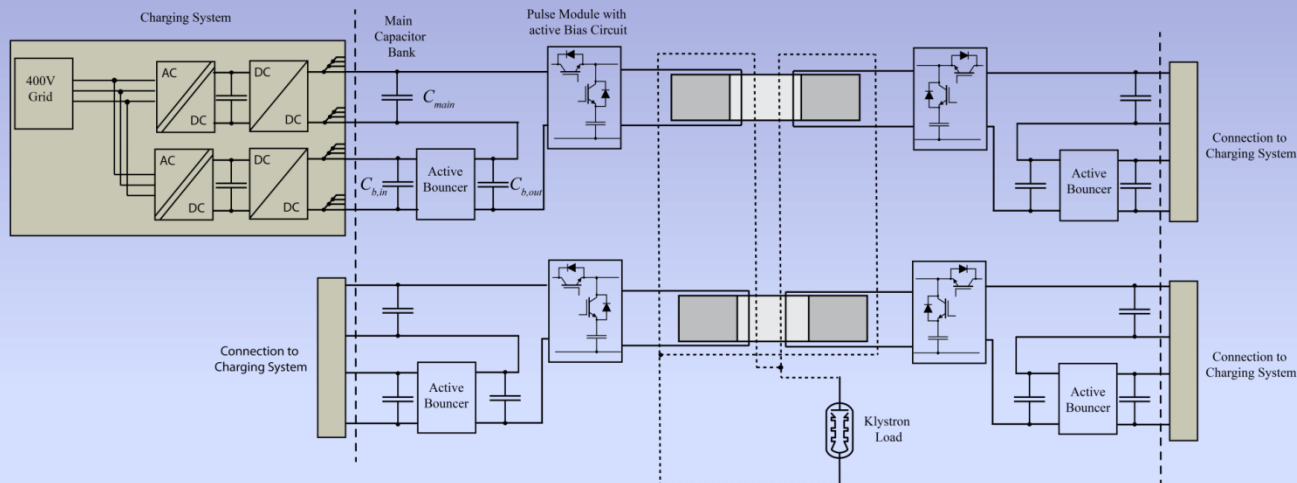

Pulse transformer design almost finished  
 Expected prototype beginning 2014  
 Active bouncer theoretical design almost finished – construction in 2014

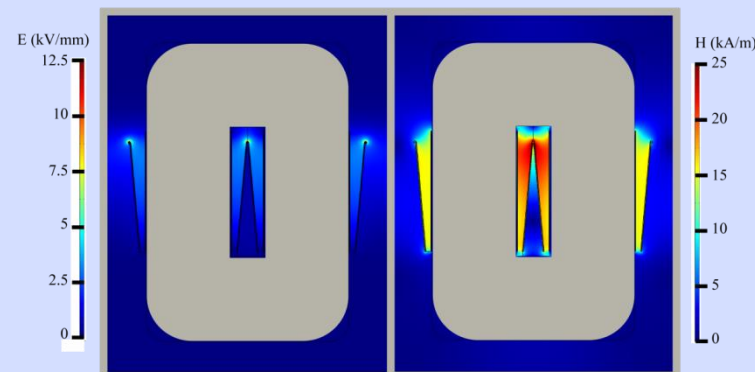

# Sub-harmonic bunching system

## Status:

RF design existing, mechanical design advanced,  
Next: launch prototype (in aluminum ?)

## Power source:

500 MHz, 15-115 kW, wide band (60 MHz) sources needed for fast phase switching. Started to discuss with industry and collaborations.

	SHB 1	SHB 2	SHB 3
Beam velocity	0.62 c	0.62 c	0.62 c
Current	5 A	5 A	5 A
Voltage	15 kV	30 kV	45 kV
Bunch form factor	0.058	0.57	0.73
Detuning	1.6 MHz	12.1 MHz	12.7 MHz

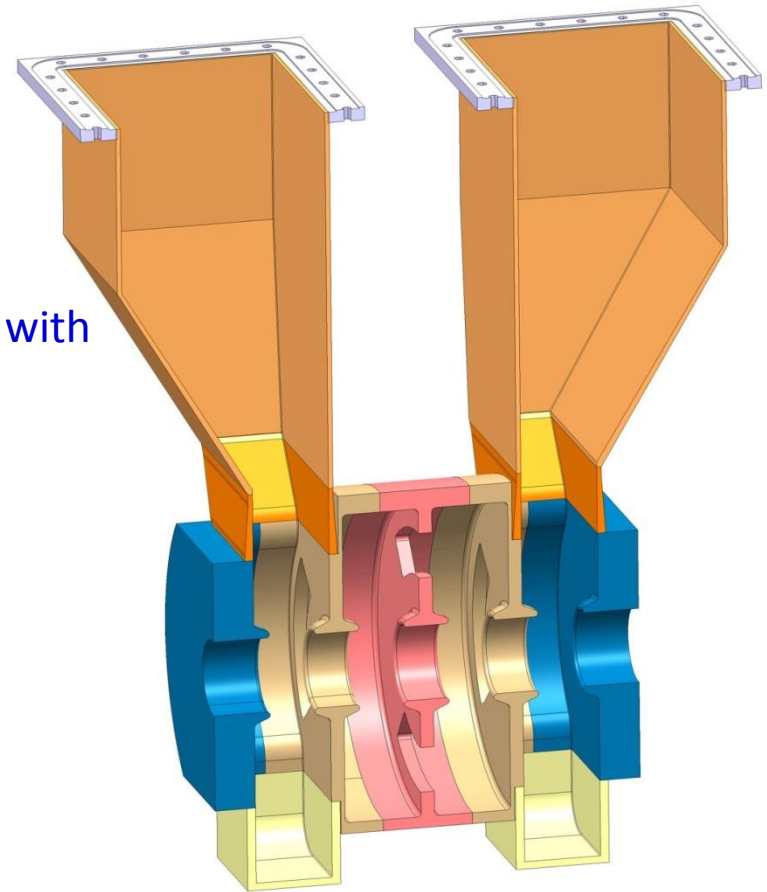



# Thermionic Gun design

140 kV, 5-7 A

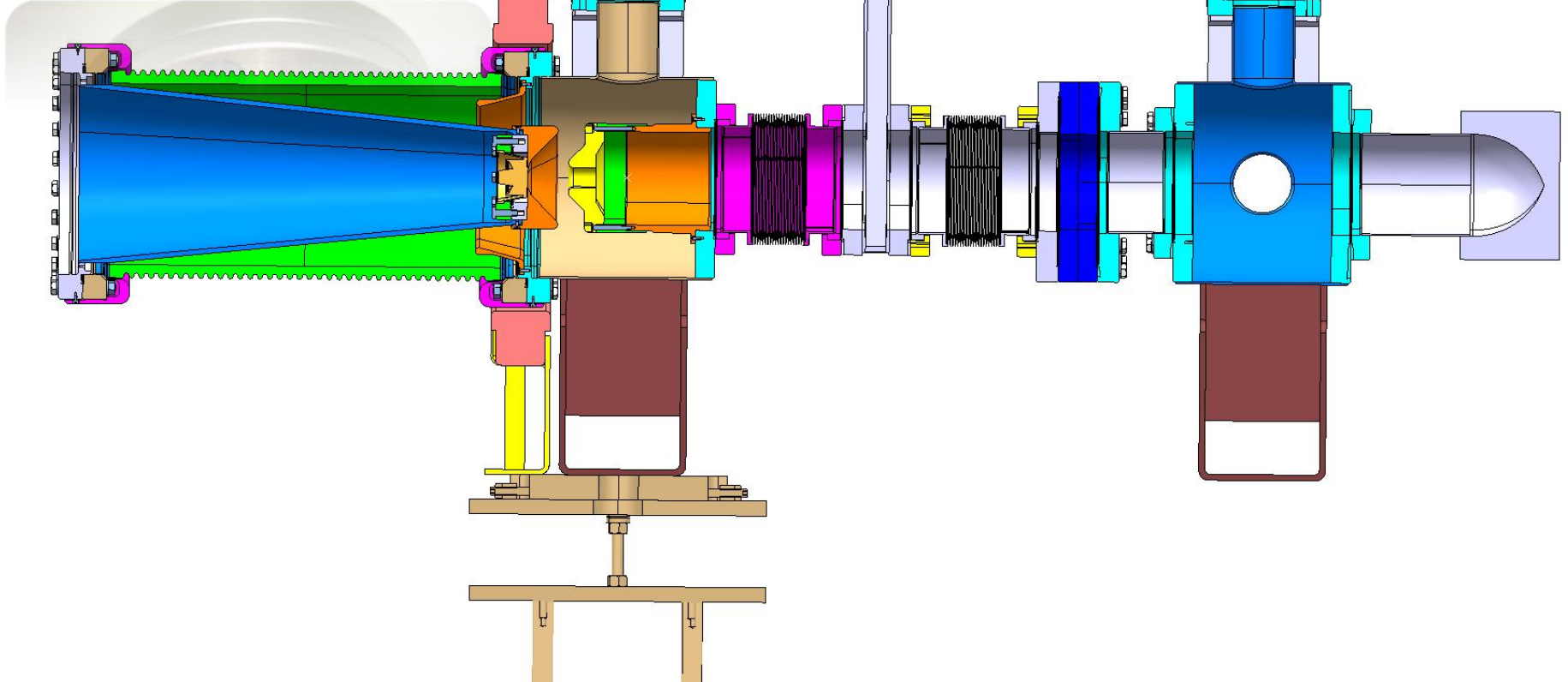

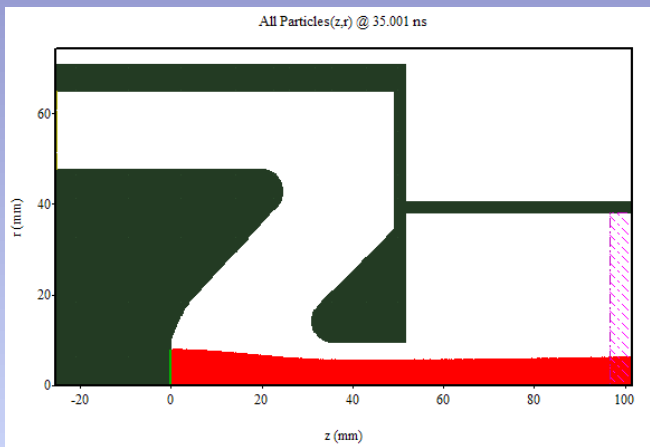

Typical MAGIC snapshot: particle positions in r-z

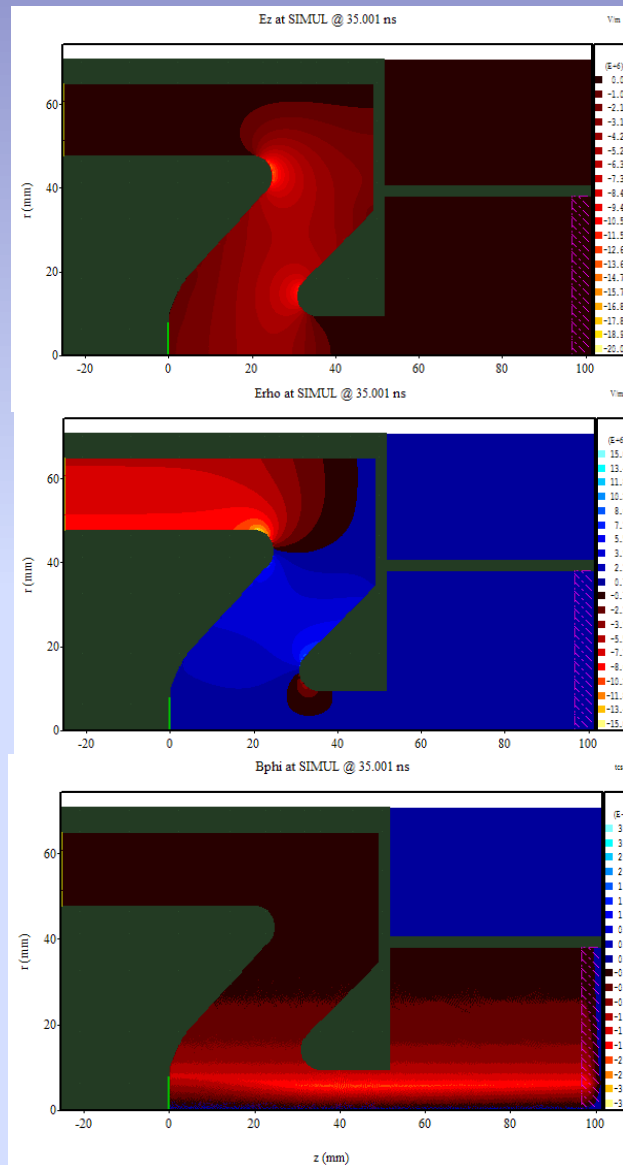
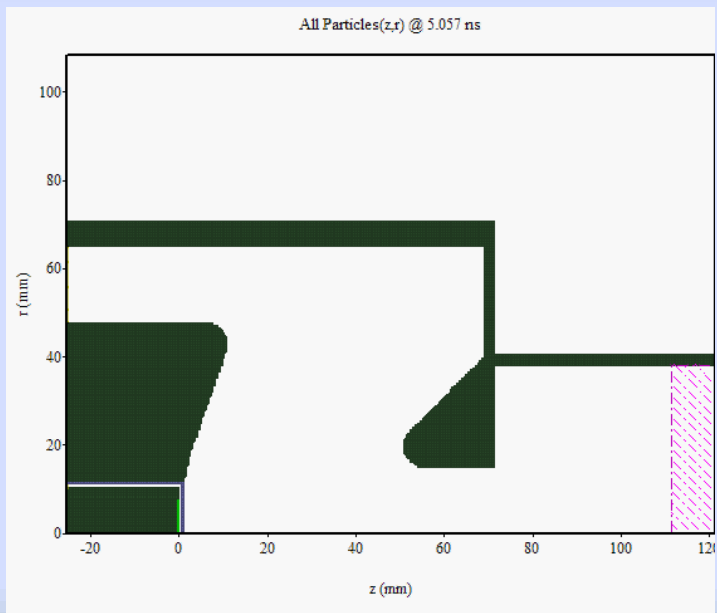

$E_z$

$E_r$

$B_\phi$

# Gun simulations

## Emittance vs voltage

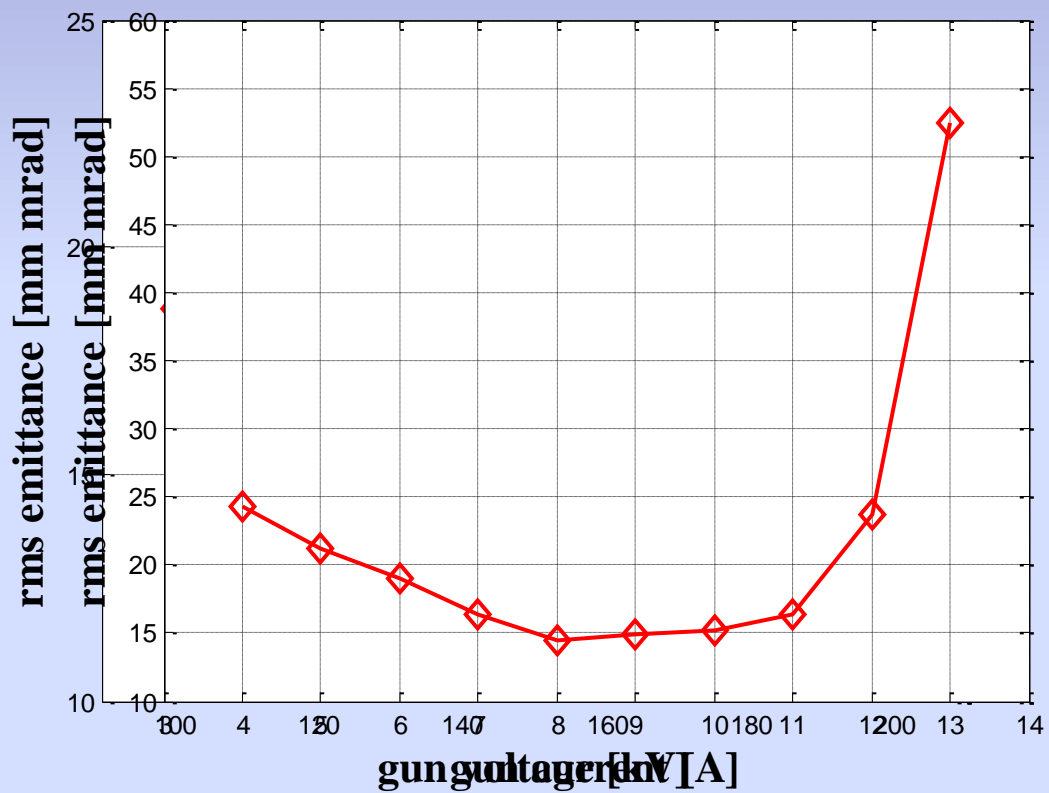

# DB-accelerator structure

RF-design existing,  
next steps: mechanical design and prototype

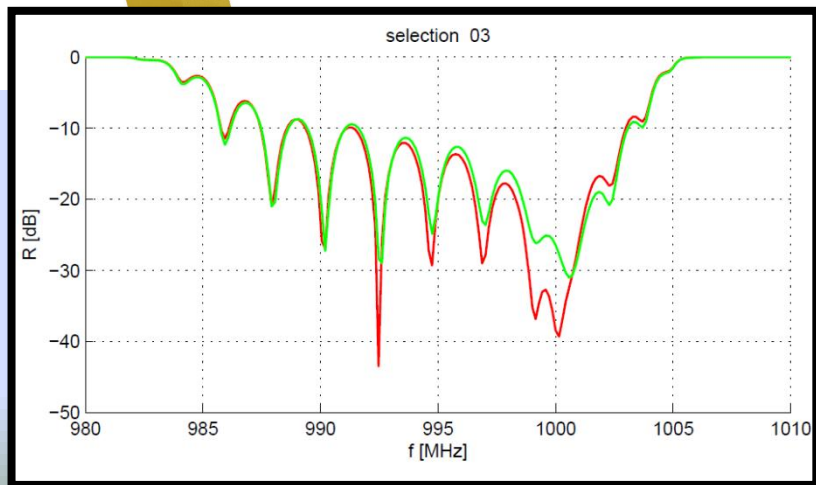
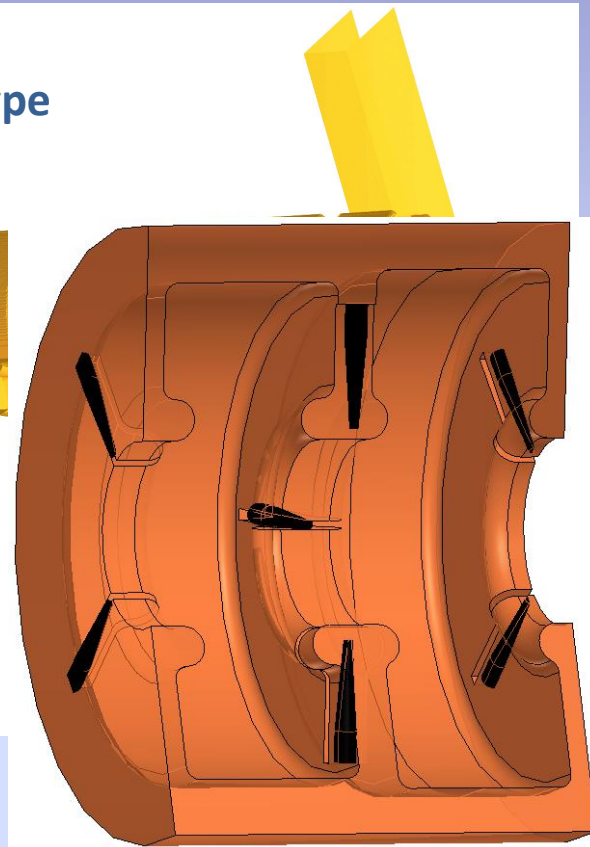

**Input and output coupler design finished**  
Correct match, input reflection < 30 dB.  
(red and green: two different geometries; red is final)

# DB-accelerator structure

f0= 1.000 GHz, BP Radius= 49.00 mm, mean(Pin)= 15.00 MW

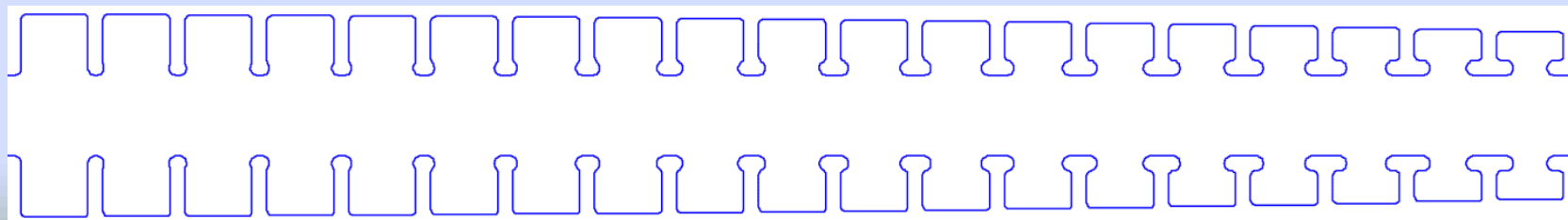
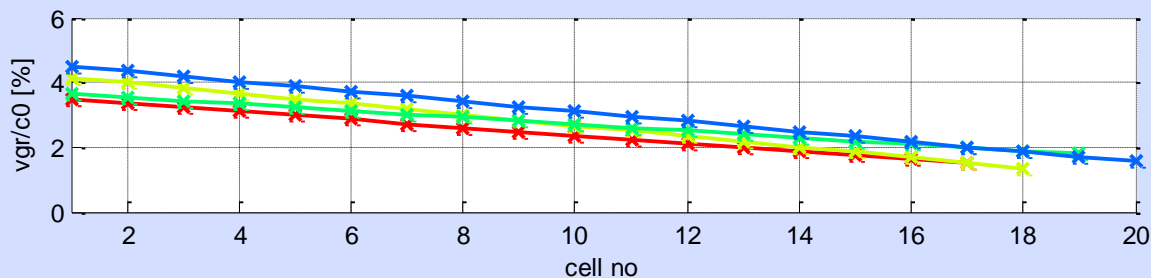
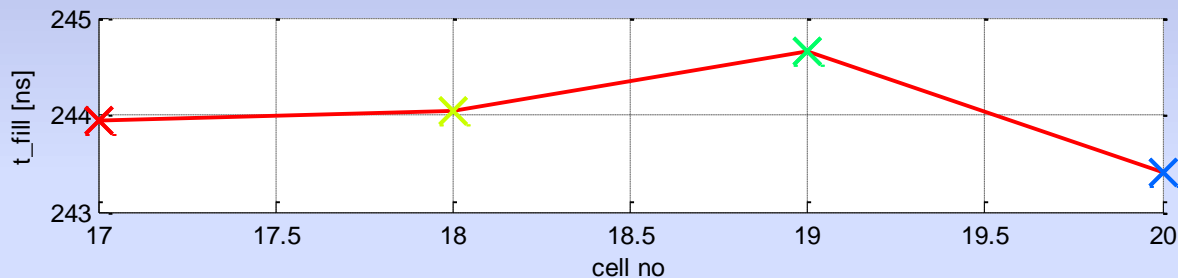
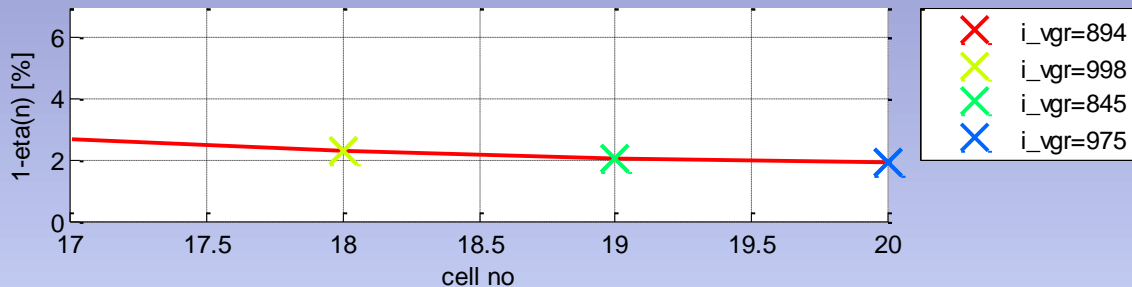

## Parameters:

$f = 999.5$  MHz

$P_{in} = 15$  MW

$R_B = 49$  mm

$N = 19$  cells

OD= 300 mm

$L = 2.4$  m

$T_{fill} = 245$  ns

$\eta_{RF-Beam} = 97.5$  %



# Conclusion and Outlook

- Challenging Drive beam frond project
- Key elements under design or manufacturing
- Large collaborative effort
  
- Hope to get some 'real' CLIC drive beam hardware to test in 2014
- CLIC collaboration workshop, February 2014



End

# Gun Test Facility

Gun test area:

former GTF available, Bldg. 162-R-004/008, needs some refurbishment

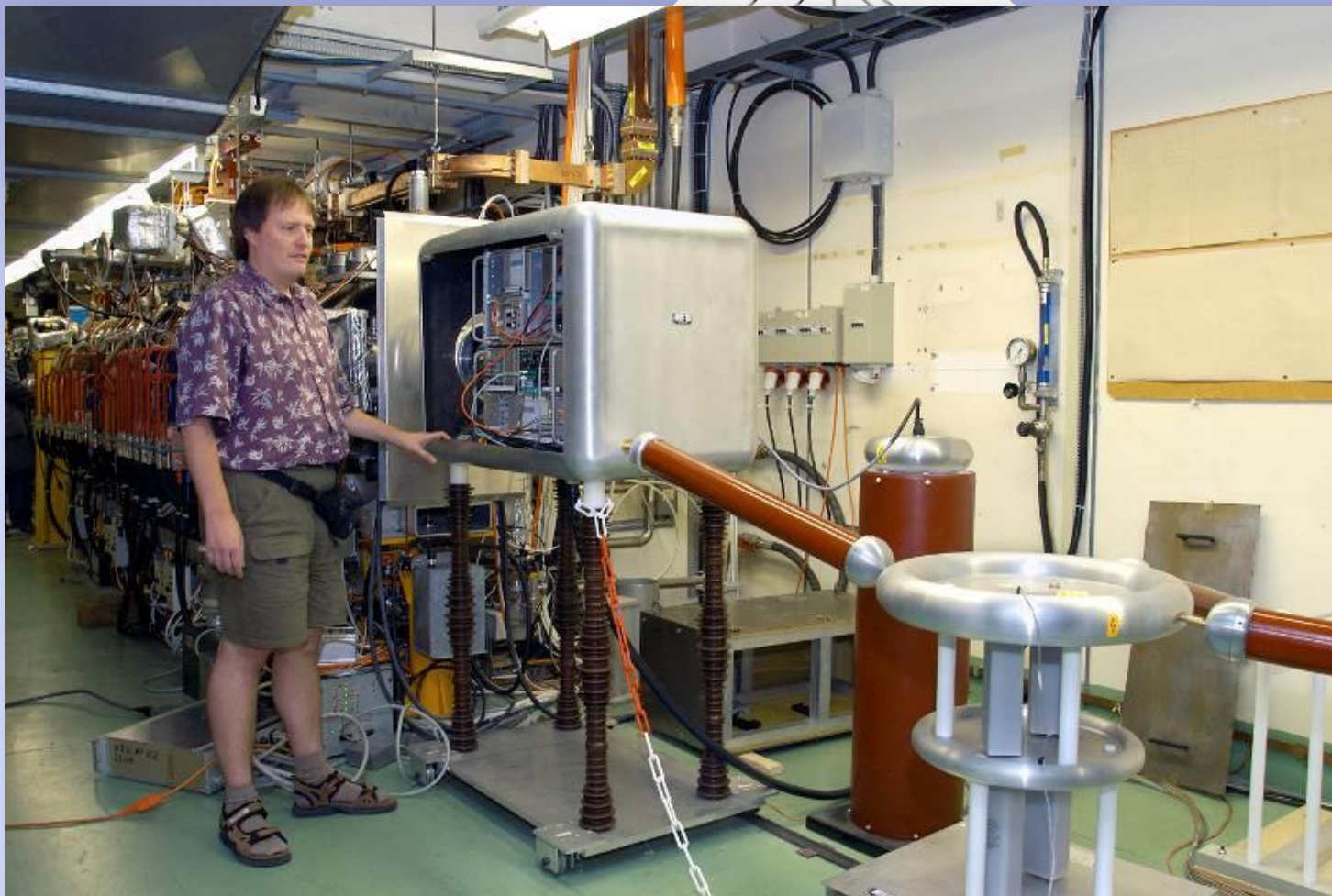





# What do we plan to do until 2016

## Optimistic and rough planning

Task	2012	2013	2014	2015	2016
Space needed		prepare gun test facility	prepare Klystron test sand	prepare injector building	injector building
Gun	conceptual design	design	GUN test facility	GUN test facility	
SHB Buncher	design	fabrication	testing		
500 MHz power source	specification		Purchase, testing		
Buncher	specification		design		
1 GHz structure	specification	design	mechanical design	manufacturing	high power test
Diagnostis	specification, purchase		IC in gun test		
LLRF		specification	fabrication+test	ready for klystron test	
1 GHz klystrons		Tender, design	fabrication of prototype	Receive Klystron 1	Klystron 2
1 GHz Modulator		R&D	R&D	Receive first MDK	MDK2
Injector integration, vacuum, controls, magnets, diagnostics	on hold	on hold	design		

Create a gun test facility to test the source  
and a high power test stand to test the klystron, modulator and rf structures

Thales



Toshiba



CPI #a



CPI #b

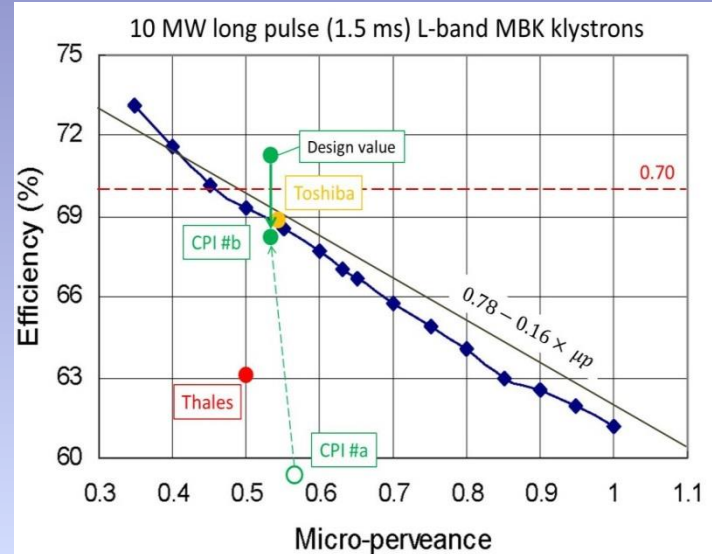

In saturation

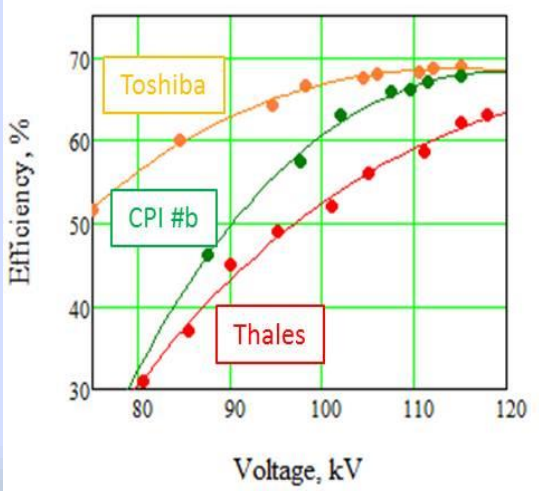

In saturation

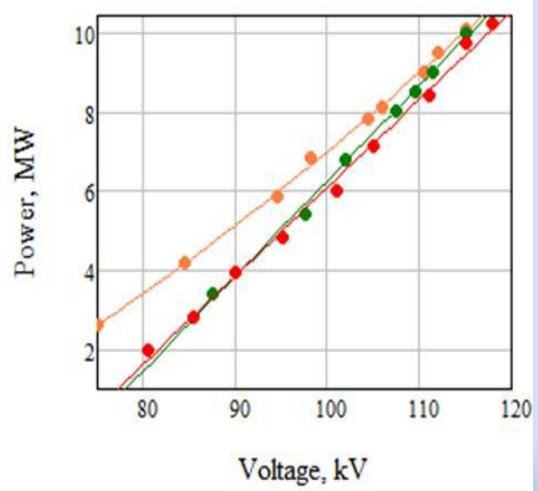

In terms of achieved RF efficiency, the klystrons with RF circuit adopted by Toshiba and CPI provides values very close to the 70%, as is specified in CLIC CDR (67.8% for CPI and 68.8% for Toshiba). **These values validate the feasibility of a slightly higher efficiency with minimised design/fabrication efforts, when scaled in frequency down to 1.0 GHz.**

# DB-Gun strategy and planning

1-2/2013	3-4/2013	1-2/2014	3-4/2014
SLAC design study based on YU156	SLAC mechanical design with YU156	Fabrication	Test
Concept for GTF	Prepare local and purchase equipment	HV-test for PS ready install equipment	Gun test
Design GUN CERN-CESTA based on YU796 and YU156 modular ?	Mechanical design based on YU796	Fabrication	Test
	Modulator design CESTA	Prototype	Prototype at CERN
Concepts for HV deck electronics	Design of pulser electronics	Fabrication and tests	Ready for use

# R&D strategy and status

- LAVAL University

Two novel active bouncer topologies under evaluation (small scale protos beginning 2014)

Monolithic transformer design almost finished – small scale proto in 2014

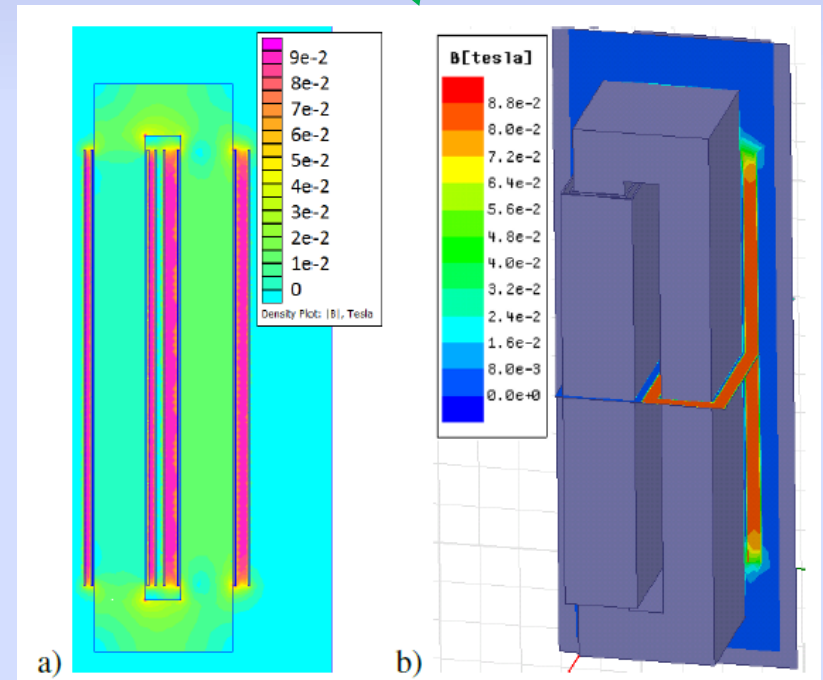
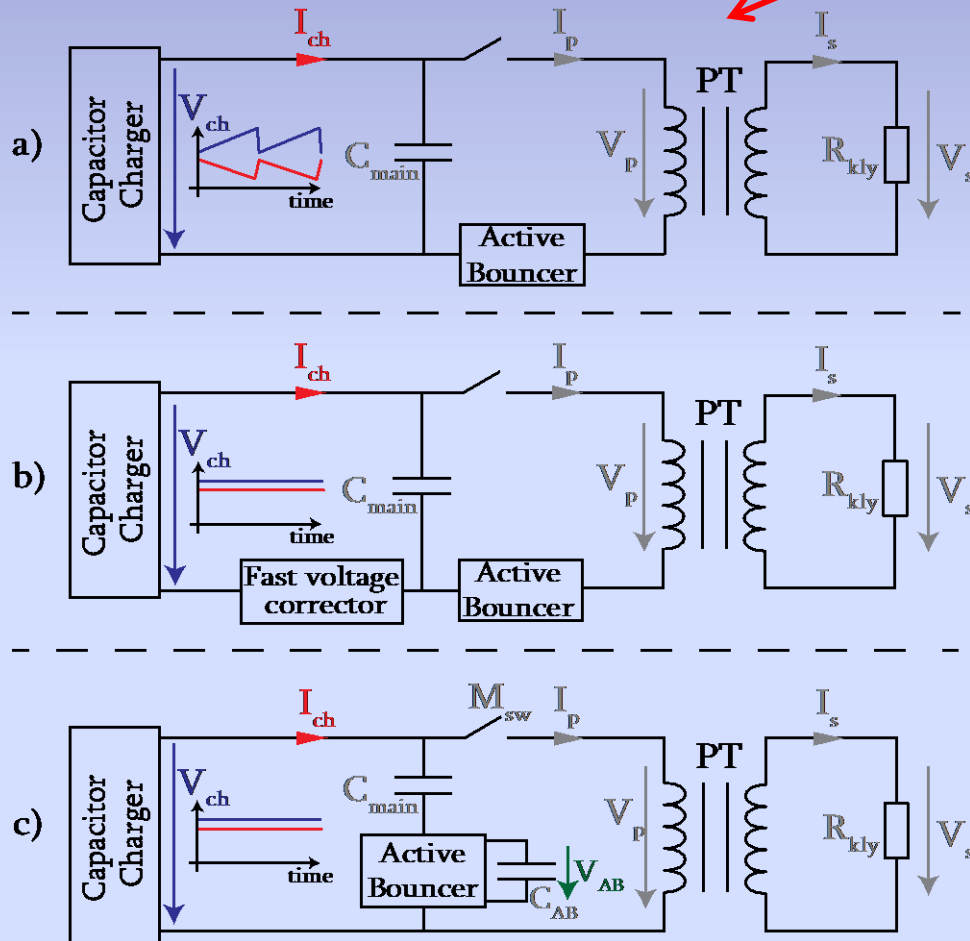

# 800 MHz SPS IOT switching test

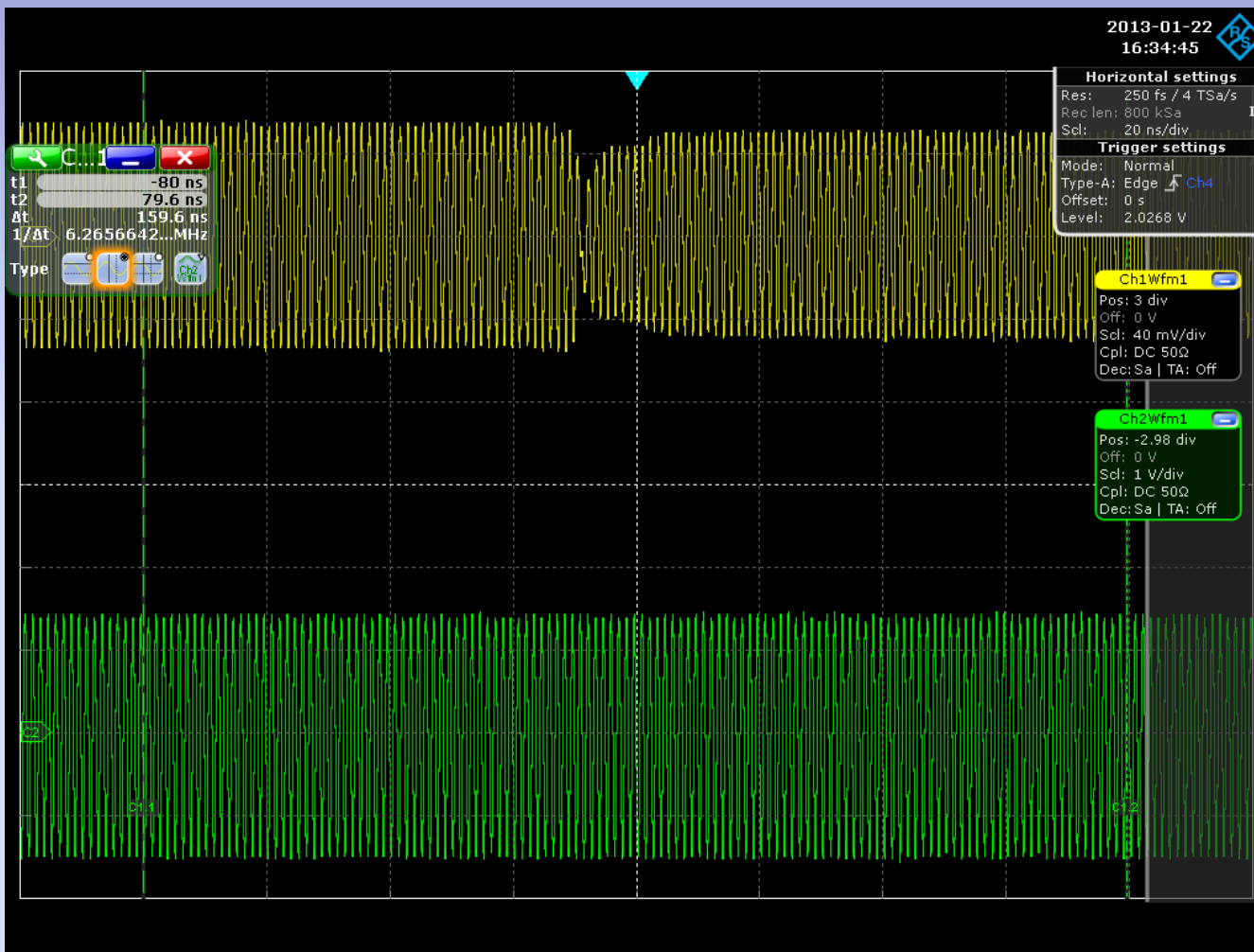

~800ns switching time → BW 6505MHz

# Thermionic Gun design

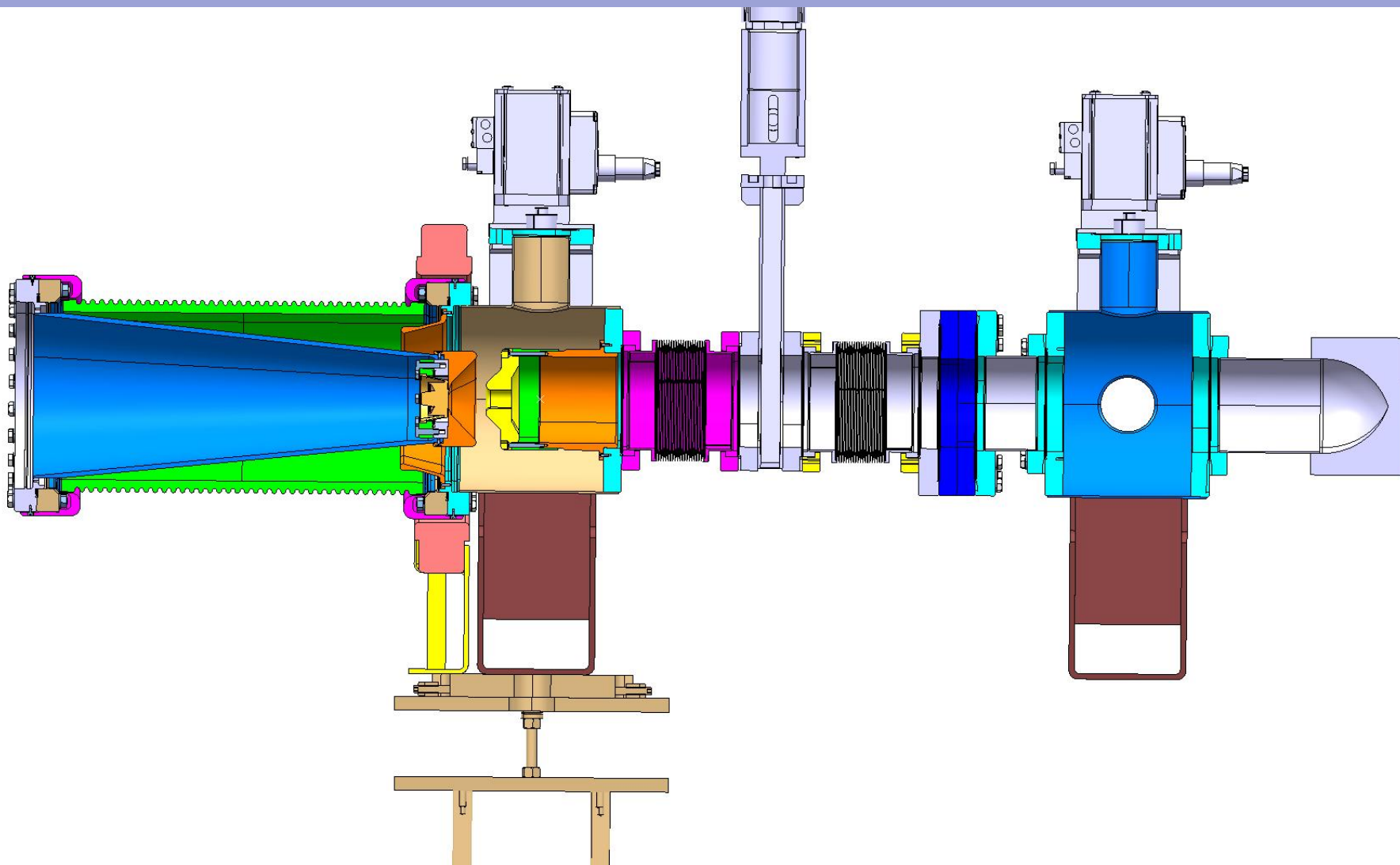

# Gun simulations Using EGUN

ANALYSIS OF OUTPUT DATA FROM EGN2(C)1988 W.B.HERRMANNSFELDT

7.000 A , COMPRESSION=2.9

ANALYSE

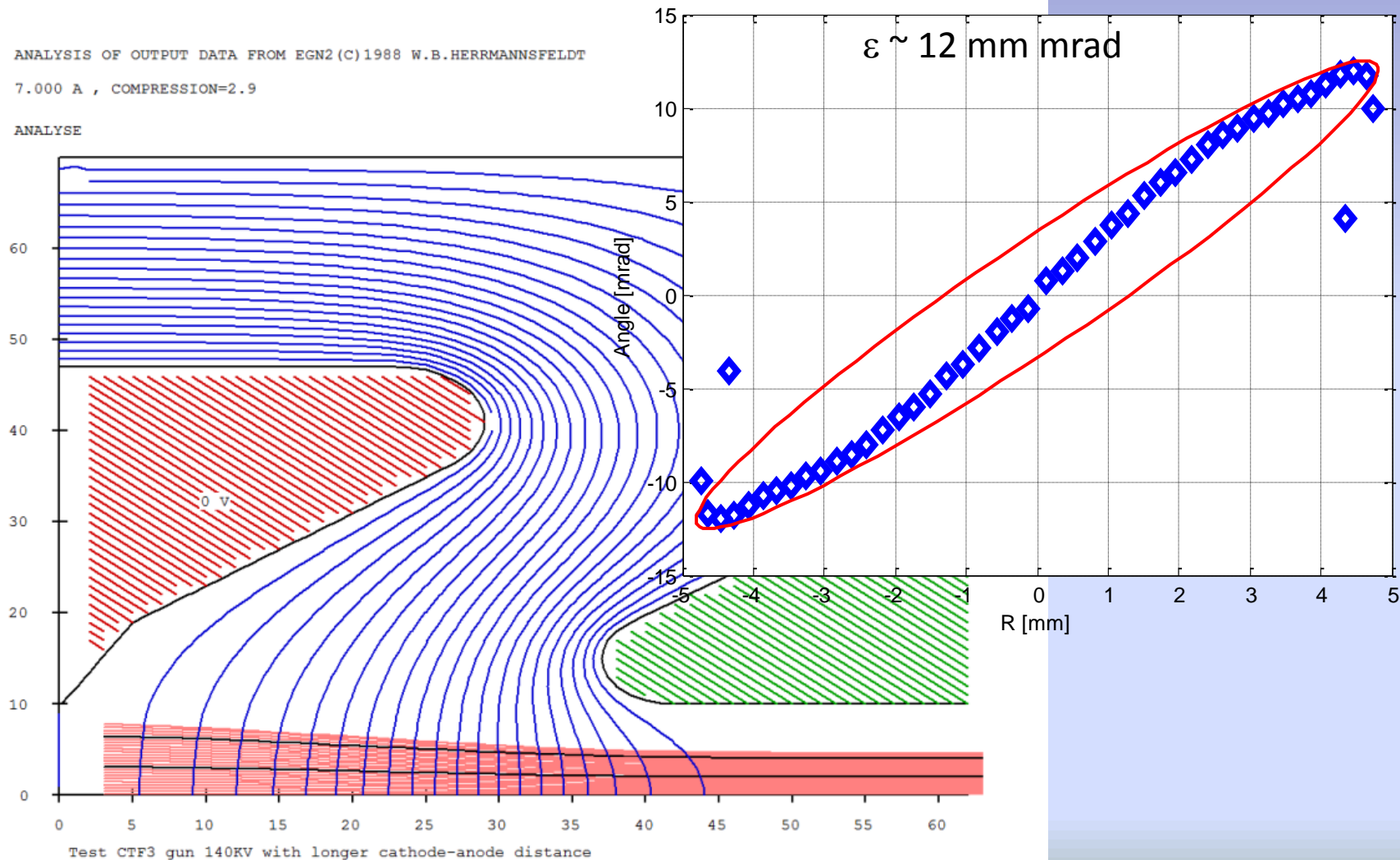

# Optimum aperture found

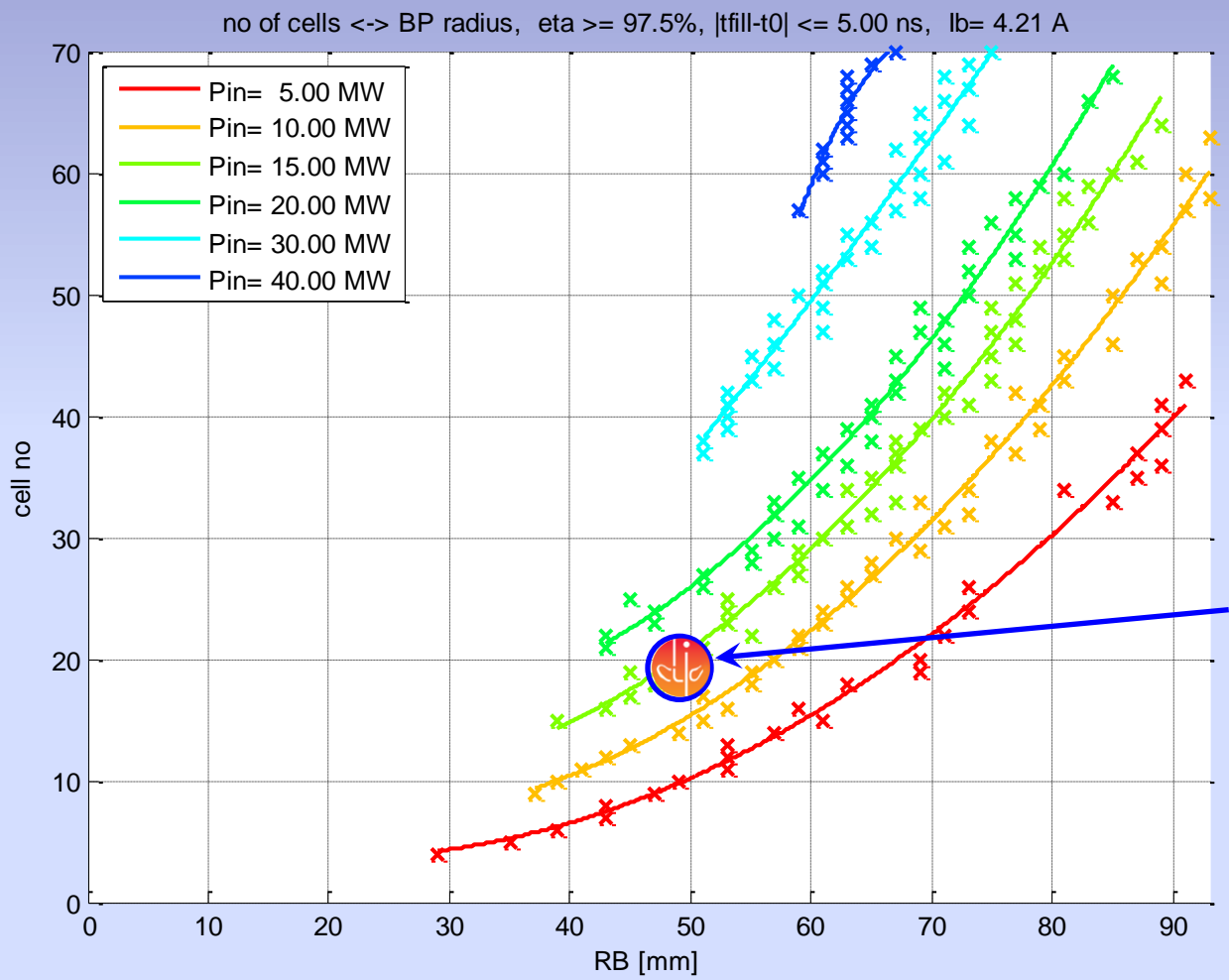

$$\eta_{RF} \geq 97.5 \%$$

$$|t_{fill} - 245 \text{ ns}| \leq 5 \text{ ns}$$

$$P_{in} = 15 \text{ MW}$$

Beam dynamic  
(Avni Aksoy):

$$R_B = 49 \text{ mm,}$$

$$N = 19 \text{ cells}$$

Rolf Wegner