



Accelerating Structures Wakefields Measurement at FACET

G. De Michele^{1,2,3}, E. Adli^{1,4}, A. Grudiev¹, A. Latina¹, D. Schulte¹, W. Wuensch¹

¹CERN, ²PSI, ³EPFL, ⁴The University of Oslo

Acknowledgement: G. Riddone¹, A. Solodko¹ for the mechanical design

PAUL SCHERRER INSTITUT

PSI

EPFL

ÉCOLE POLYTECHNIQUE
FÉDÉRALE DE LAUSANNE

Overview

- Prototype RF design
- Simulation of the experiment with PLACET
- Prototype mechanical design
- Current schedule

Transverse wakefield suppression

The main performance issues for the CLIC main linac accelerating structures are:

- high accelerating gradient (100MV/m)
- RF-to-beam efficiency
- transverse wakefields suppression

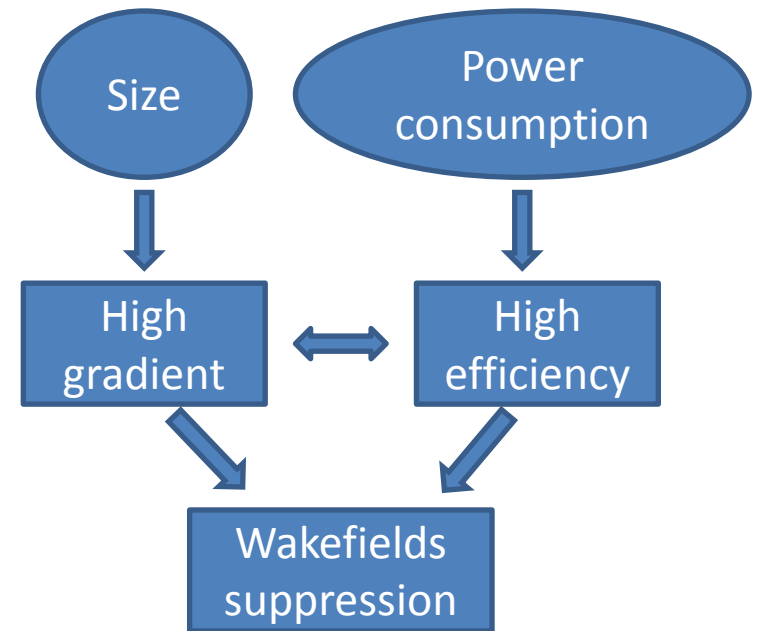

The 100MV/m accelerating gradient is a consequence of the 3TeV collision energy while limiting the machine length below 50km. The performance of the accelerating structures drives the efficiency and cost of CLIC.

The accelerating RF structure

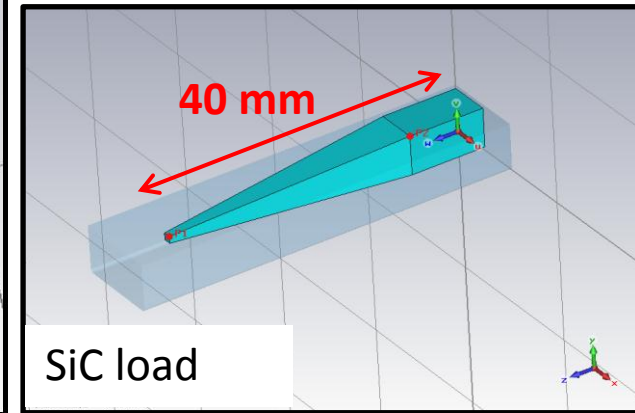
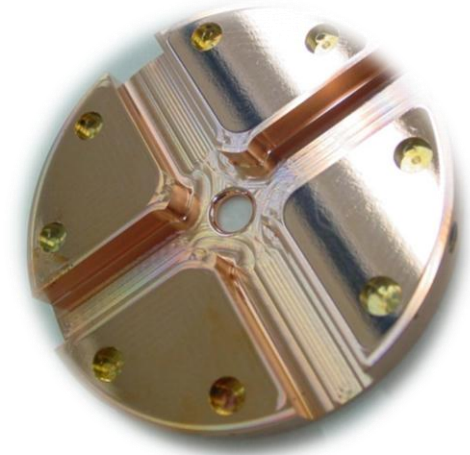
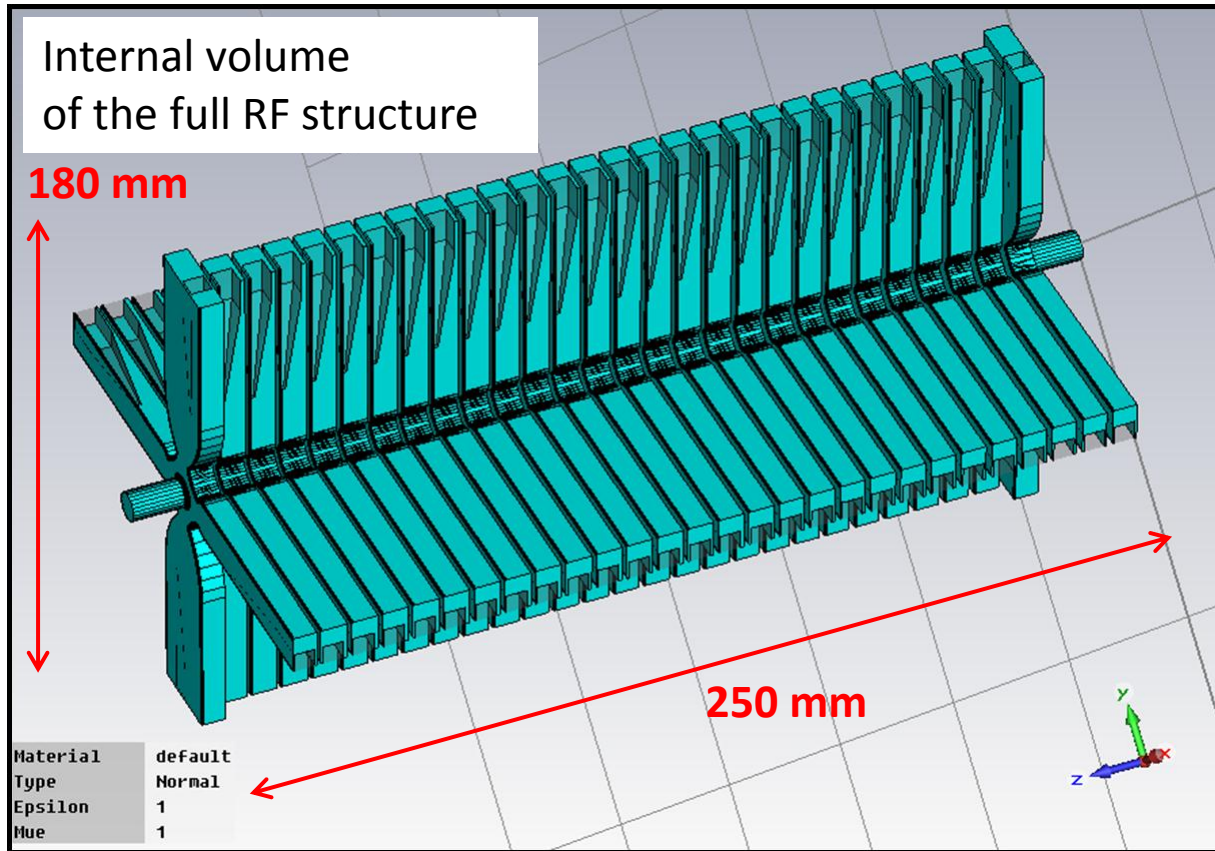

- travelling wave structure at 12GHz
- 26 accelerating cells
- double-feed coupler

- four damping waveguides in each cell
- 104 silicon carbide loads

Wakefields simulations

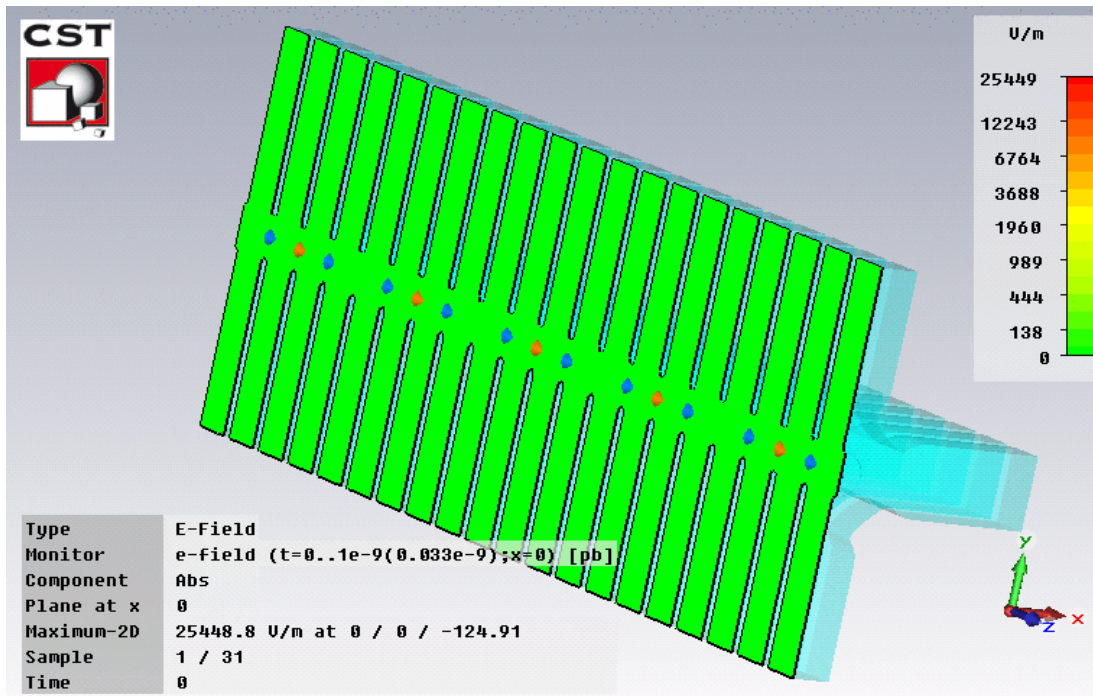

The accurate simulation of wakefields, even in complex structure, can lowered the design cost. This experiment will give us a feedback on the goodness of our simulations tools (CST PS, GdfidL).

$$p_z = -\frac{q_1 q_2}{c} W_z(s)$$

$$\vec{p}_\perp = \frac{q_1 q_2}{c} \vec{W}_\perp(s)$$

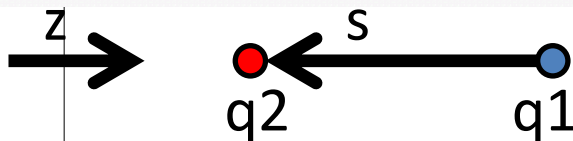

$$\vec{W}_\perp(\vec{r}, \vec{r}', s) = \frac{1}{q_1} \int_{z_1}^{z_2} dz [\vec{E}_\perp + c(\hat{z} \times \vec{B})]_{t=(z+s)/c}$$

$$W_z(\vec{r}, \vec{r}', s) = -\frac{1}{q_1} \int_{z_1}^{z_2} dz [E_z(\vec{r}, z, t)]_{t=(z+s)/c}$$

$$\vec{V}_\perp(s) = \int_0^\infty ds' \lambda(s-s') \vec{W}_\perp(s')$$

$$V_z(s) = \int_0^\infty ds' \lambda(s-s') W_z(s')$$

The predicted transverse wakefield

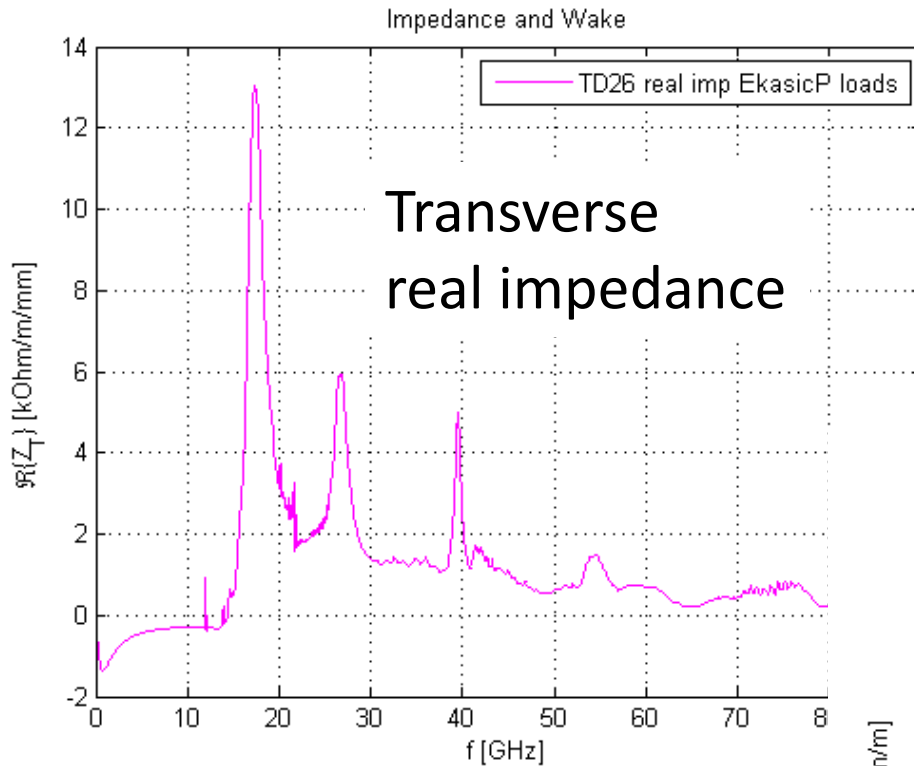

Absolute value
of the envelope of
the transverse wake

LCWS, UT

Three main dipolar
bands in the
impedance spectrum

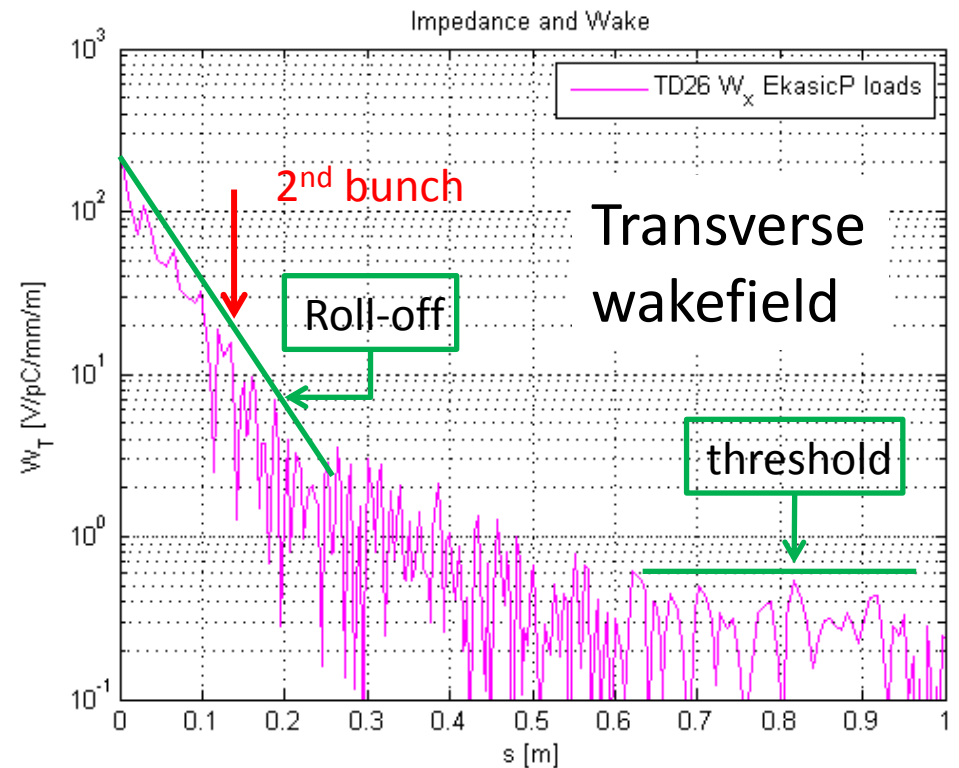

Overview

- Prototype RF design
- **Simulation of the experiment with PLACET**
- Prototype mechanical design
- Current schedule

Why FACET?

- Possibility of having driving and witness bunches with positrons and electrons.
- Adjustable bunch spacing for a timing span behind the driving bunch.
- Bunch length flexibility: ideally shorter than 1mm in order to resolve the 3rd dipole band which shows up a peak around 40GHz.

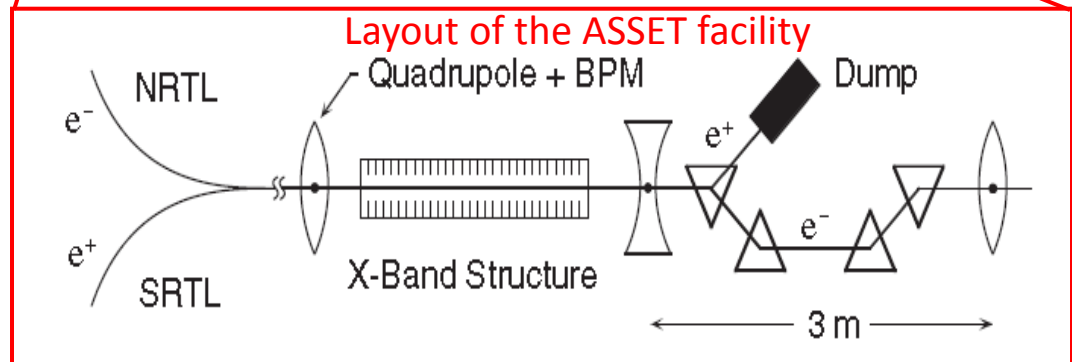
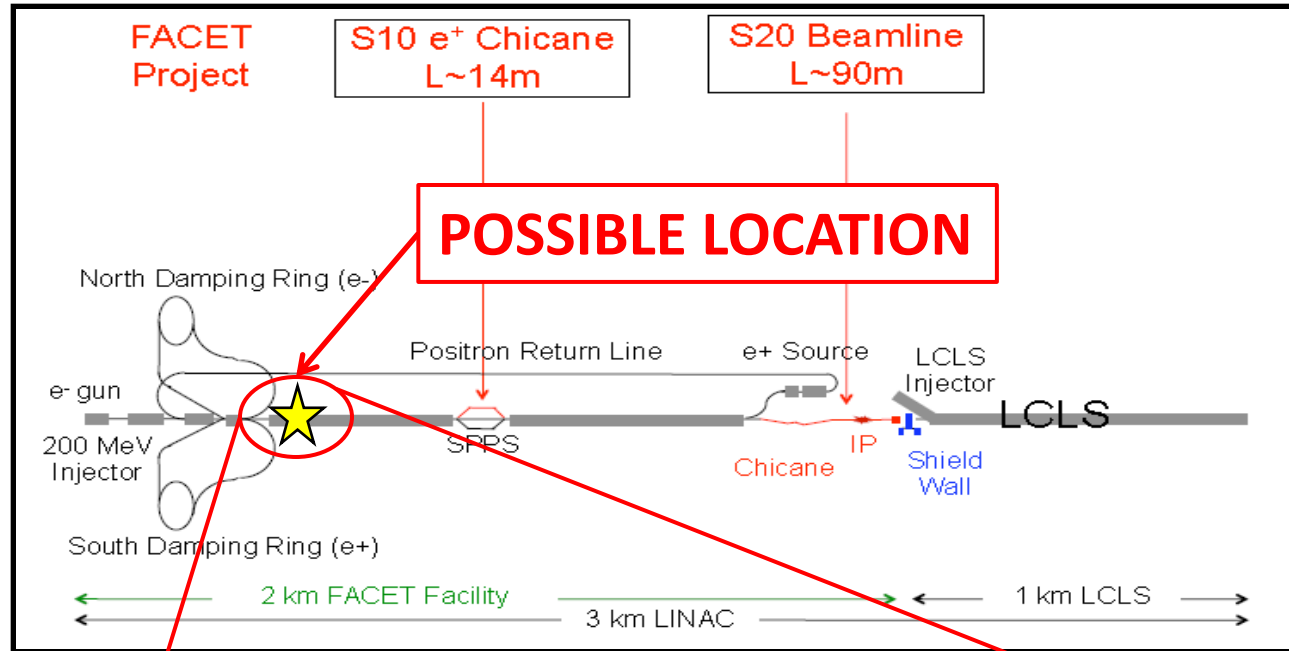

Where in FACET

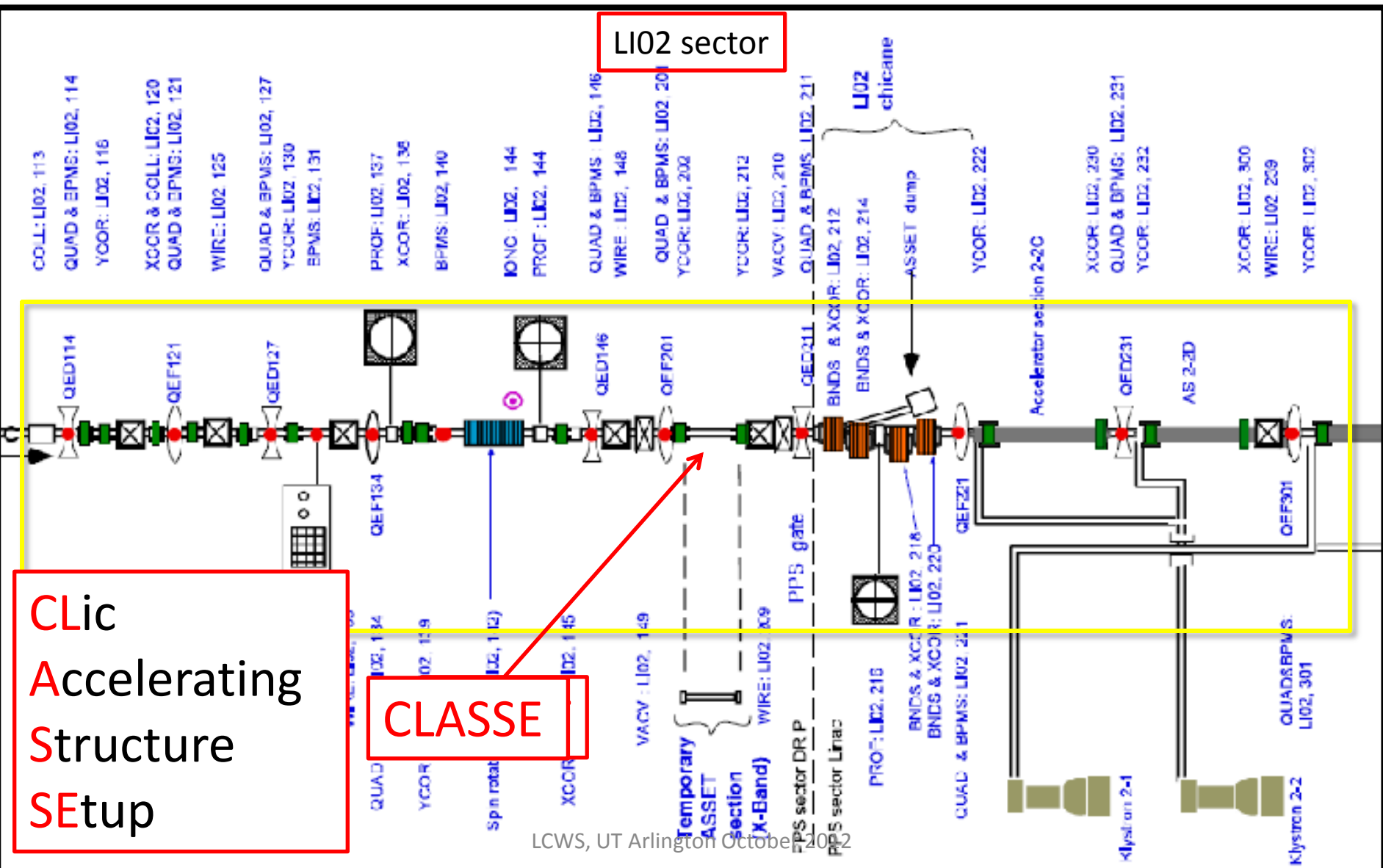

Experiment simulations with tracking code PLACET

A. Latina
G. De Michele

- BPMs upstream and downstream of the structure are needed in order to determine the bunch offset in the structure, as well as dipole corrector magnets to generate this offset.

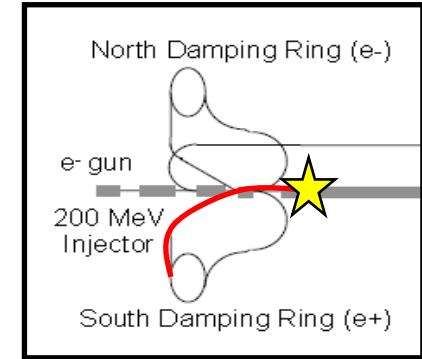

- Lattice simulations from the extraction kicker in DR to LI02
- Only BPMs downstream of correctors are sensitive to the correction itself. That means that the lattice response is triangular.

Response Matrix of all BPMs due to all Y-correctors applying 1kV for each corrector

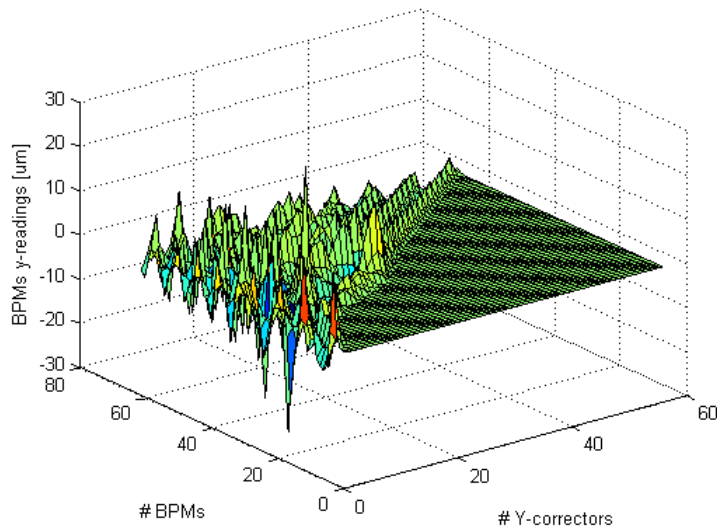

Response Matrix of all BPMs due to all X-correctors applying 1kV for each corrector

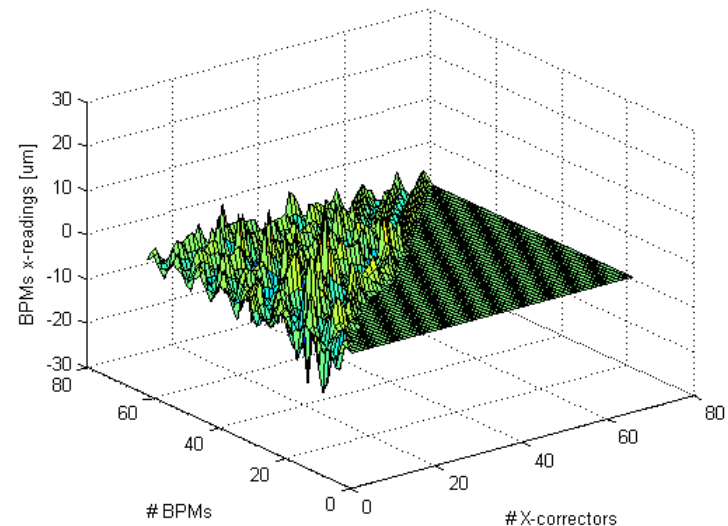

Positrons: offset scan to drive wakefields

The BPMs just before and after the RF prototype are LI02, 201 and LI02, 211.

With only two correctors in the SRLT seems possible to shift the positron beam in the RF prototype. The shifts (-1:0.5:1) on the drive bunch are shown at the location of the RF structure (66 to 70m)

Positron beam X-offsets in BPMs M020201T and M020211T

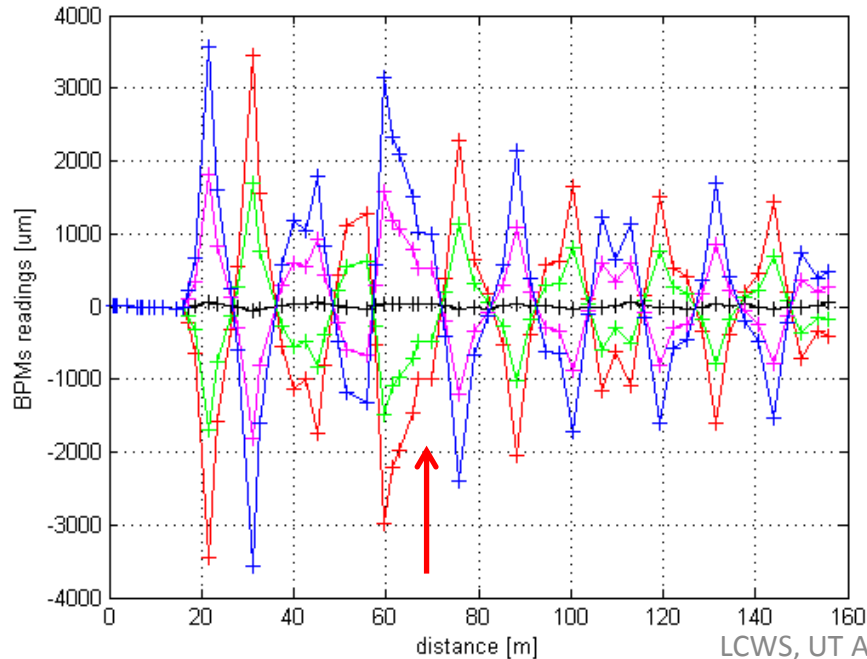

Positron beam Y-offsets in BPMs M020201T and M020211T

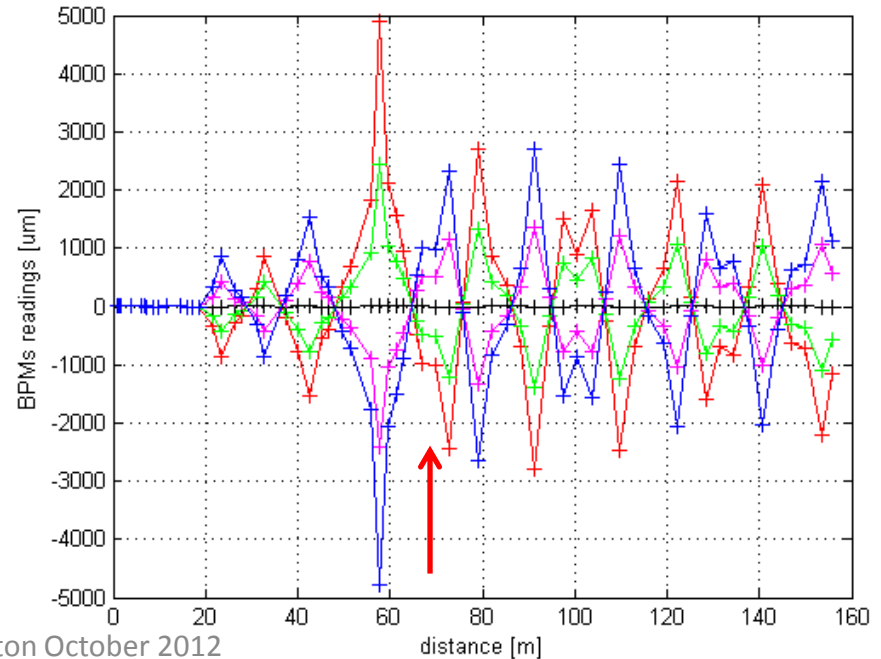

BPMs resolution

From the experiment proposal:

The transverse wake-field $W_{\perp}(t)$ is normalized in units of the drive bunch offset, drive bunch charge and structure length. In a case study where $Q_d = 3 \text{ nC}$, $E_w = 1.19 \text{ GeV}$, $L = 1.5 \text{ m}$, $W_{\perp}(t) = 1 \text{ V/pC/mm/m}$, $\Delta y_d = 0.5 \text{ mm}$ one obtains a deflecting angle $\Delta\Phi_y = 1.89 \mu\text{rad}$. In order to resolve this angle a single BPM located downstream at 1 m distance should have a resolution better than $2 \mu\text{m}$.

An accurate data analysis is required

- Good knowledge of the optics is essential
- Orbit fit to determine the kick

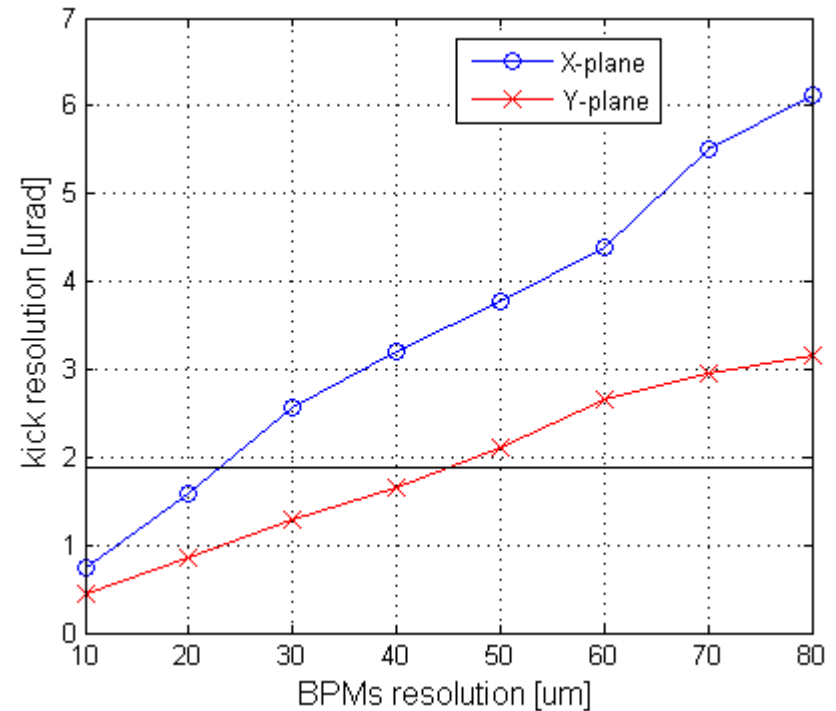
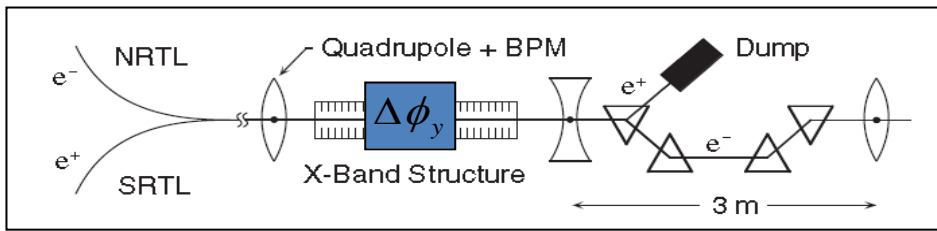

Re-constructed kick from R-matrices before and after the experiment region

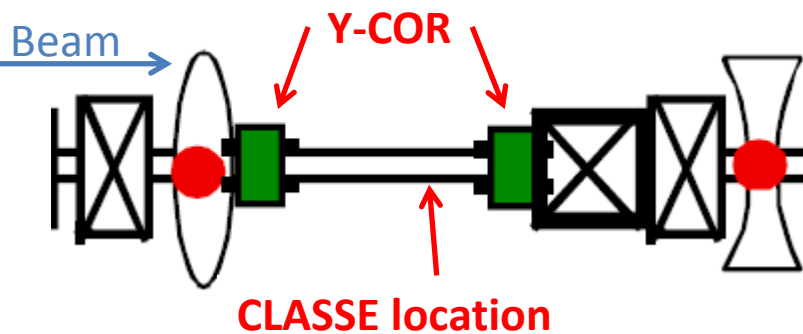
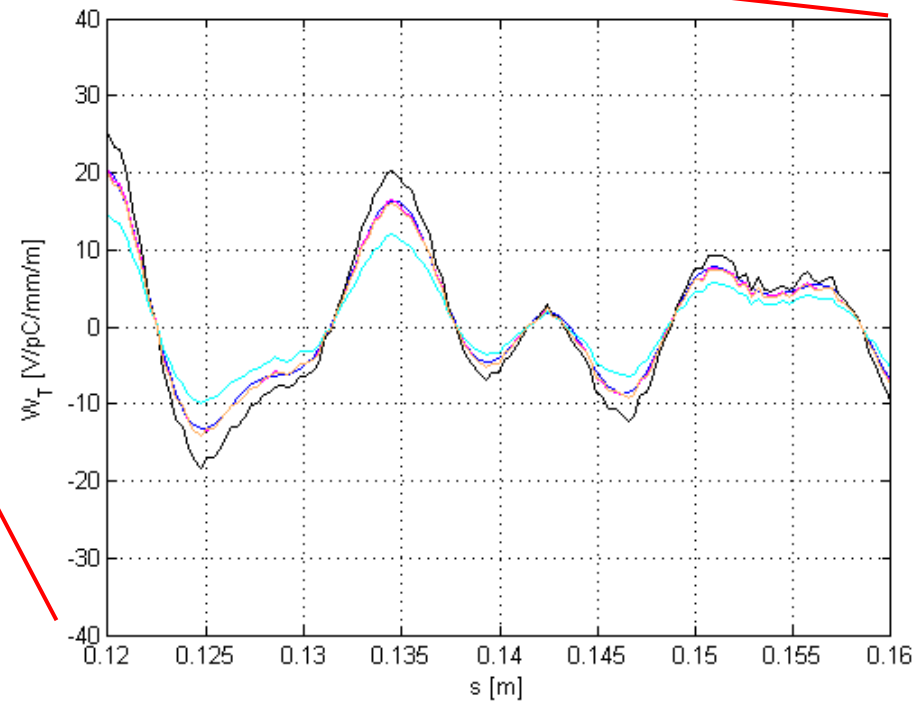
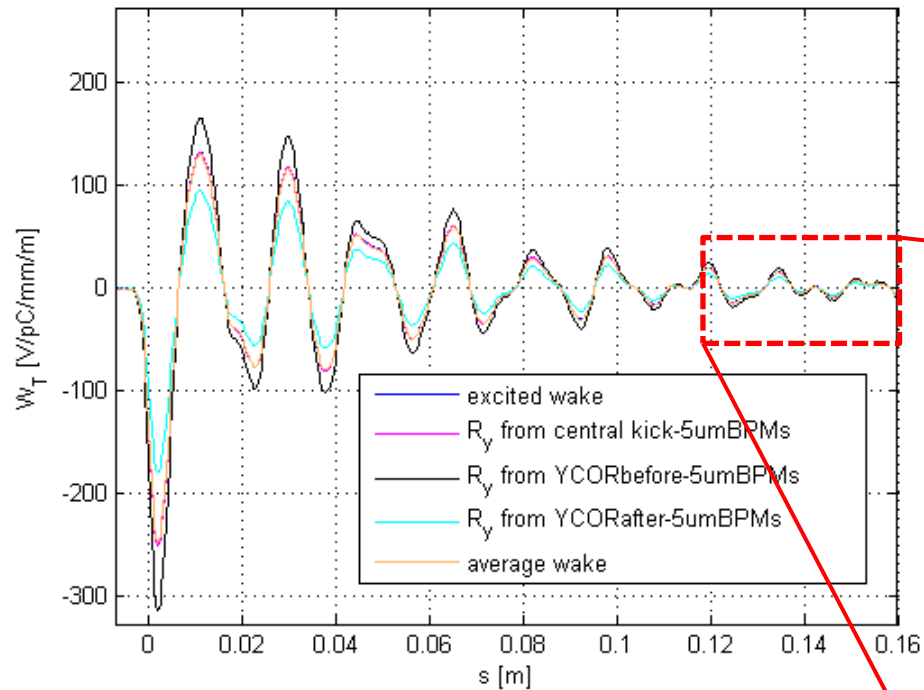

BPMs acquisition in 10sec at 10Hz

We will calculate the **standard deviation of the mean** and not of the measurements. This will give us a better resolution of BPMs. Below, PLACET simulations performed with 5um resolution on BPMs.

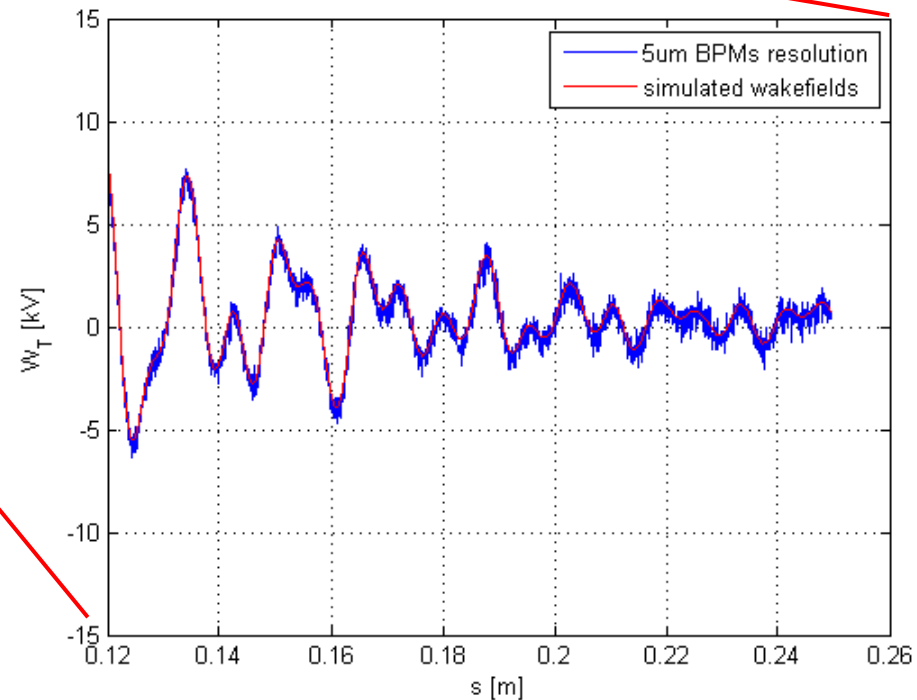
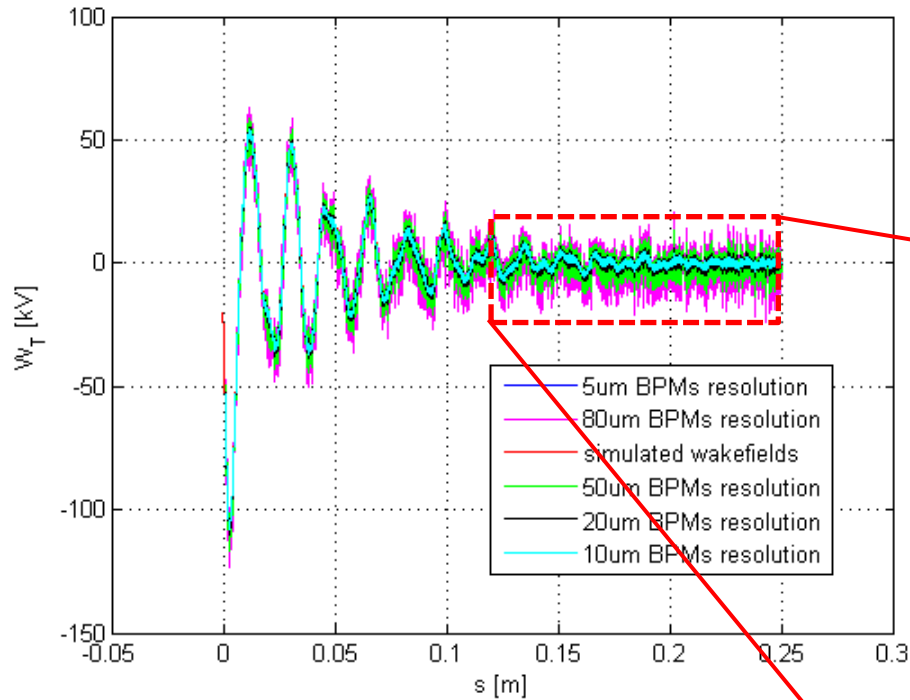

Overview

- Prototype RF design
- Simulation of the experiment with PLACET
- **Prototype mechanical design**
- Current schedule

CLASSE prototype scheme

- six TD26 accelerating structures
- simple vacuum tank
- no RF power
- clamped aluminum cells
- available length: 76.80 inches
- dimensions: 1753x675x569mm (plus vacuum pumps length)
- Total weight: ~390 kg

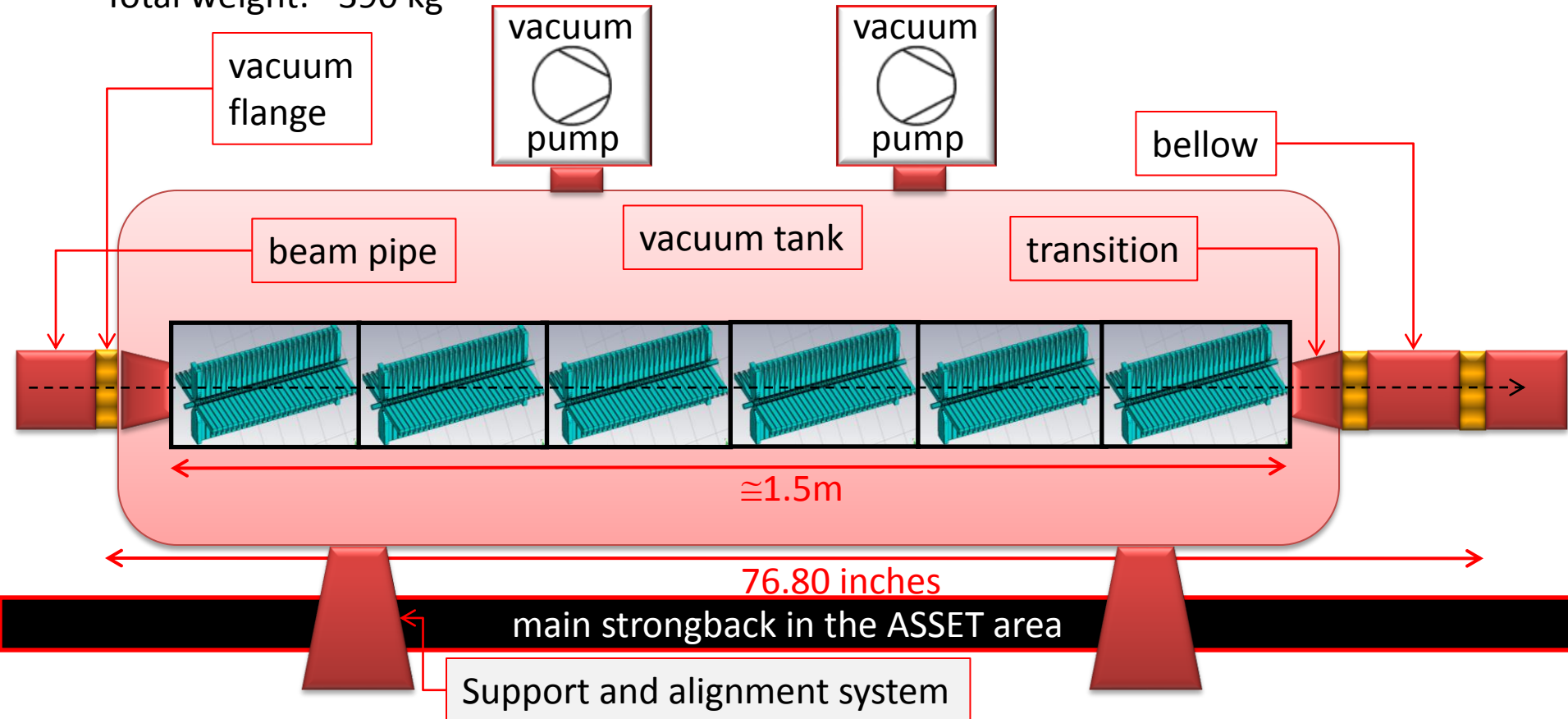

CLASSE prototype mechanical design (1/2)

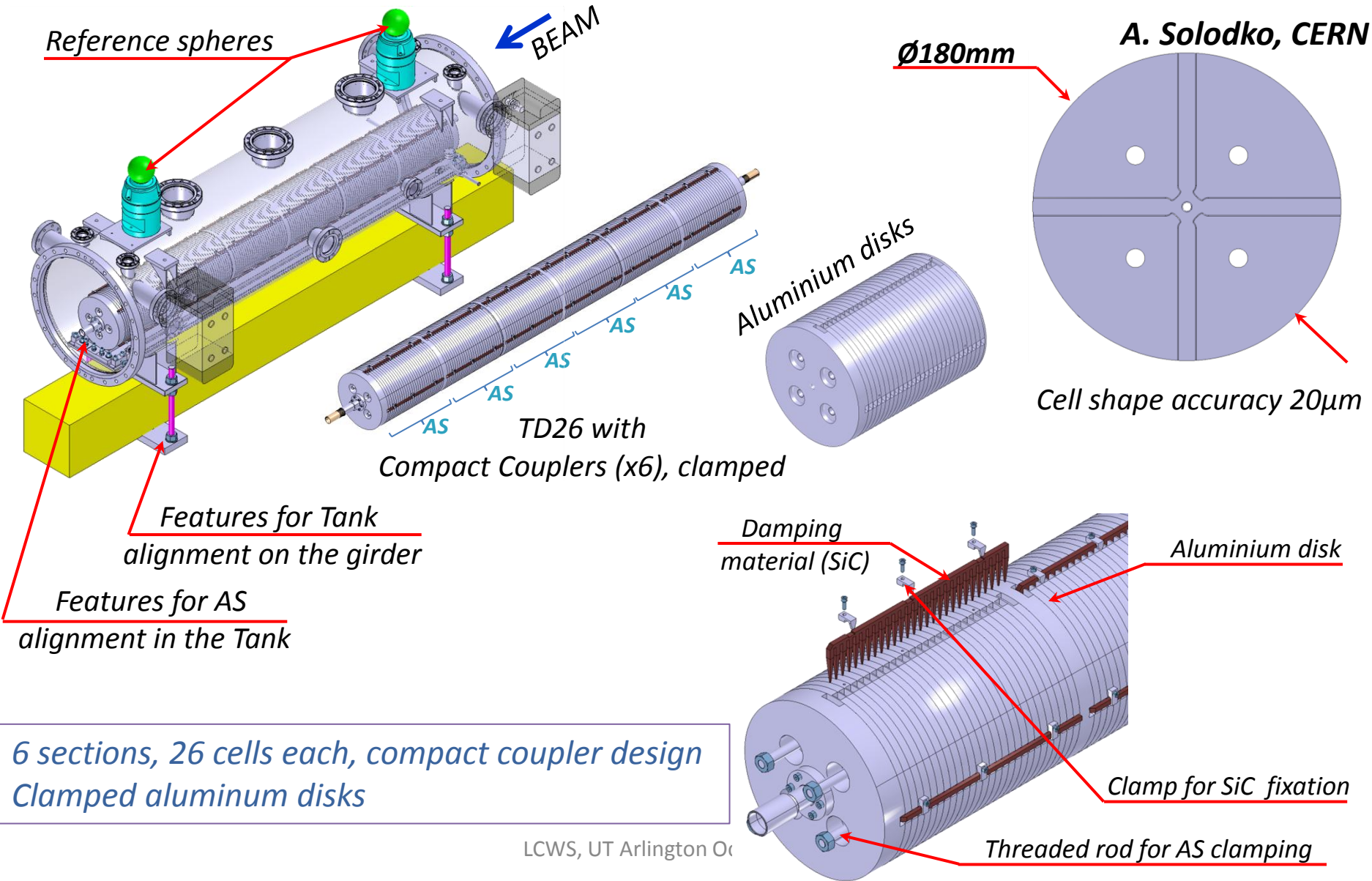

6 sections, 26 cells each, compact coupler design
Clamped aluminum disks

CLASSE prototype mechanical design (2/2)

Frames for AS fixation

Blocks for horizontal AS alignment (x4)

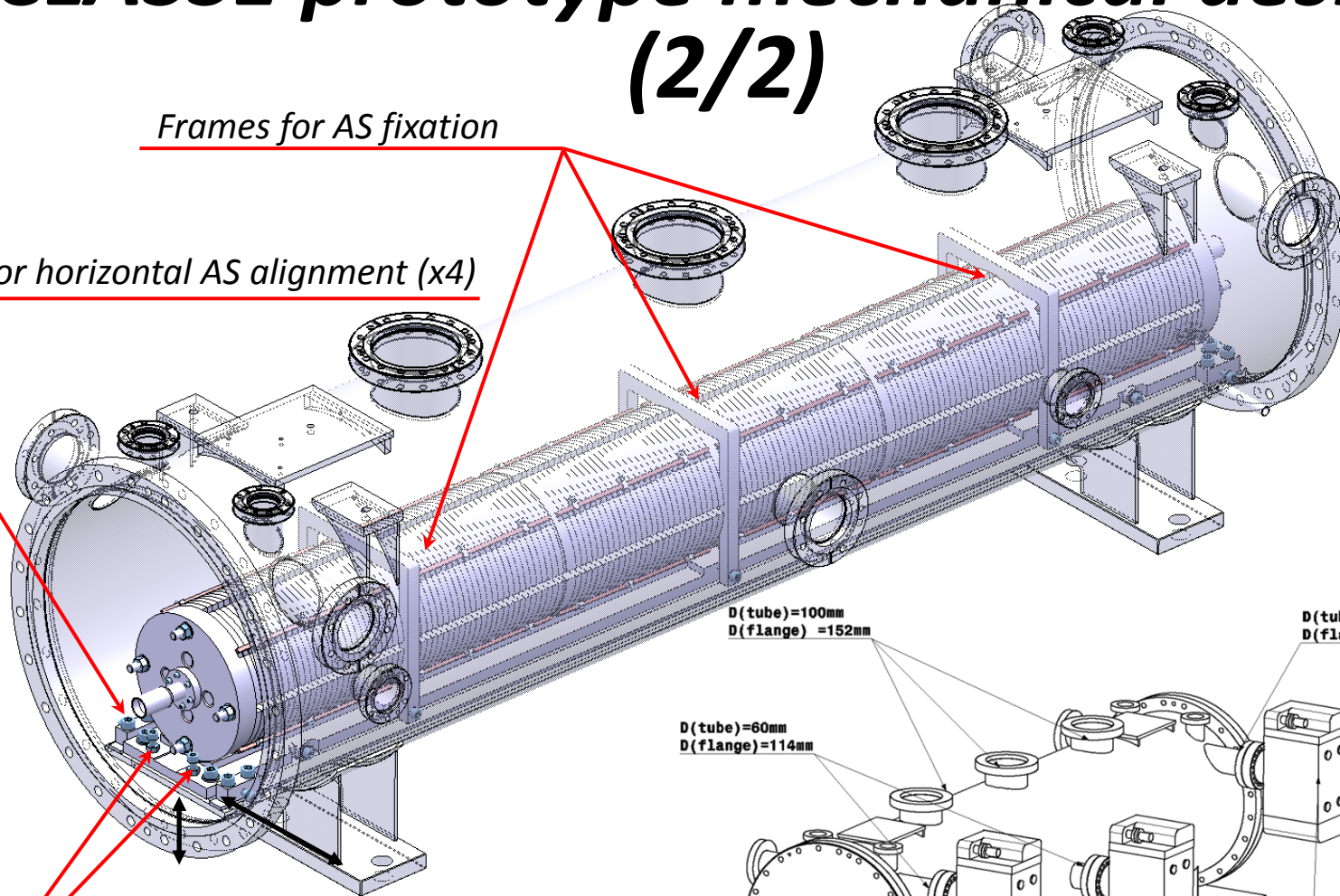

D (tube) = 100mm
D (flange) = 152mm

D (tube) = 60mm
D (flange) = 114mm

D (tube) = 60mm
D (flange) = 114mm

Screws for vertical AS alignment (x5)

- Deflection of the structure under gravity has been checked.

Possible positions of ion pumps
(noble diode pumps, 53-55 l/s)

Overview

- Prototype RF design
- Simulation of the experiment
- Prototype mechanical design
- **Current schedule**

Prototype Production Plan

1		FACET prototype production	160 days	Tue 05/06/12	Mon 14/01/13
2		Working on 2D	11 days	Tue 07/08/12	Tue 21/08/12
3	✓	Check interface with existing layout	4 days	Tue 07/08/12	Fri 10/08/12
4		Approval of disk drawings	5 days	Tue 14/08/12	Mon 20/08/12
5	✓	Approval of component drawings	5 days	Wed 15/08/12	Tue 21/08/12
6		Tank modification	32 days	Mon 03/09/12	Tue 16/10/12
7		Tank modification	20 days	Mon 03/09/12	Fri 28/09/12
8		Tank cleaning	10 days	Mon 01/10/12	Fri 12/10/12
9		Leak test	2 days	Mon 15/10/12	Tue 16/10/12
10		Tendering process	66 days	Tue 05/06/12	Tue 04/09/12
11	✓	Technical spec for SiC	5 days	Tue 05/06/12	Mon 11/06/12
12	✓	Tendering process	15 days	Tue 12/06/12	Mon 02/07/12
13	✓	Technical spec for discs	5 days	Wed 08/08/12	Tue 14/08/12
14		Tendering process	15 days	Wed 15/08/12	Tue 04/09/12
15		Part production	80 days	Tue 21/08/12	Mon 10/12/12
16		Standard - precision parts manufacturing	3 mons	Wed 22/08/12	Tue 13/11/12
17		High - precision parts manufacturing	45 days	Wed 05/09/12	Tue 06/11/12
18		SiC machining	80 days	Tue 21/08/12	Mon 10/12/12
19		Raw material request and supply	1 mon	Tue 21/08/12	Mon 17/09/12
20		Machinig	3 mons	Tue 18/09/12	Mon 10/12/12

- The structure will be ready for shipping in mid-January. Most likely it could arrive at SLAC in mid-February
- Beam time of 6 shifts: 1-2 shifts per day followed by 1-2 days break-time for offline data analysis

Thank you