



# CLIC MDI STATUS

Lau Gatignon / CERN

On behalf of the MDI Working Group

LC2013 Workshop, Hamburg, 28 May 2013

# OUTLINE

- Introduction
- QD0 prototype measurements
- QD0 pre-alignment
- QD0 stabilisation
- IP feedback
- Anti-solenoid compensation
- Post-collision line (back to MDI since 2012)
- Coming soon: study option with QD0 in tunnel

# The CLIC interaction region: one IP, two Experiments

 **Push-Pull scheme**

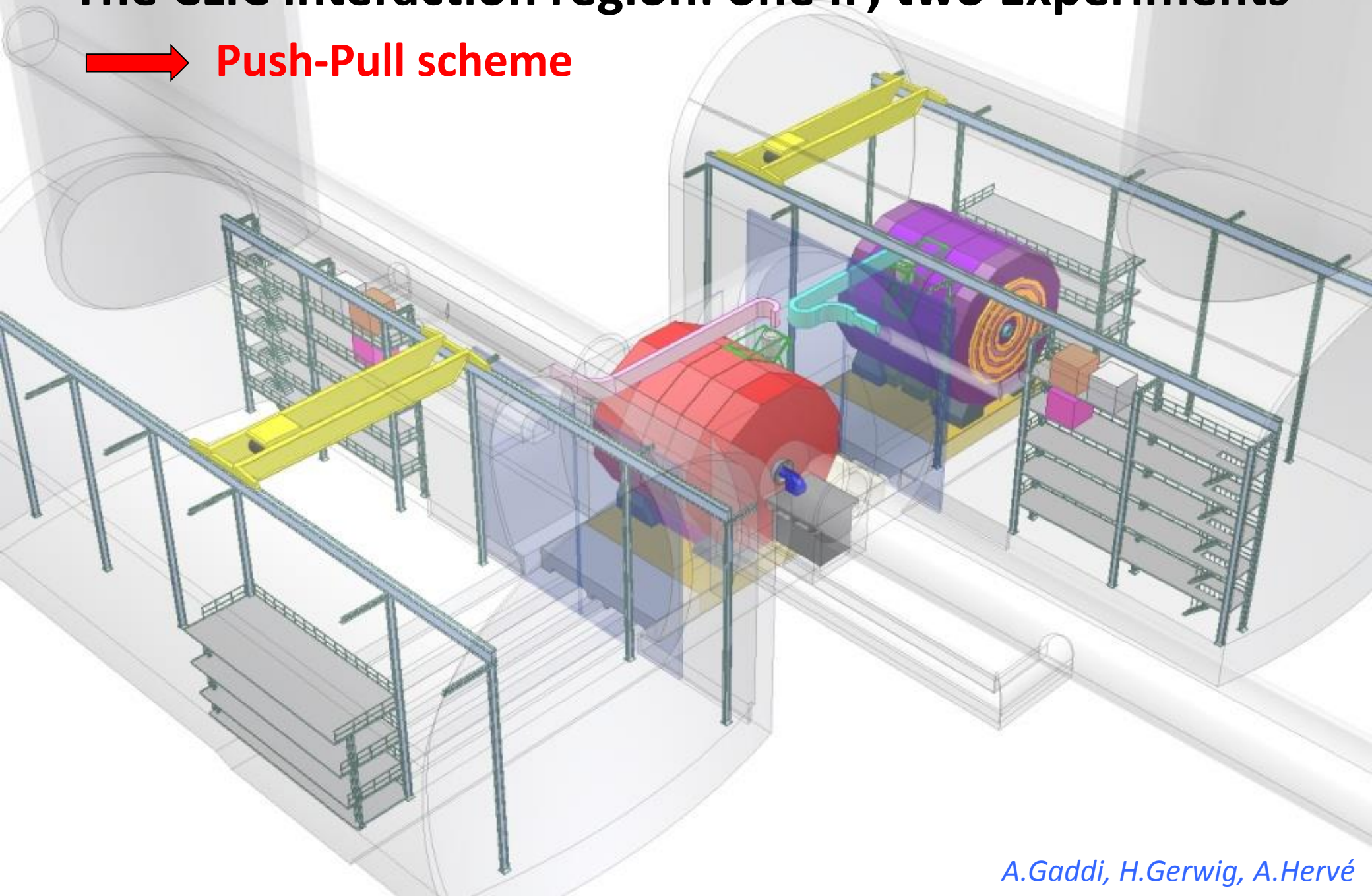

e.g.: CLIC\_SID DETECTOR

*N.Siegrist, H.Gerwig*

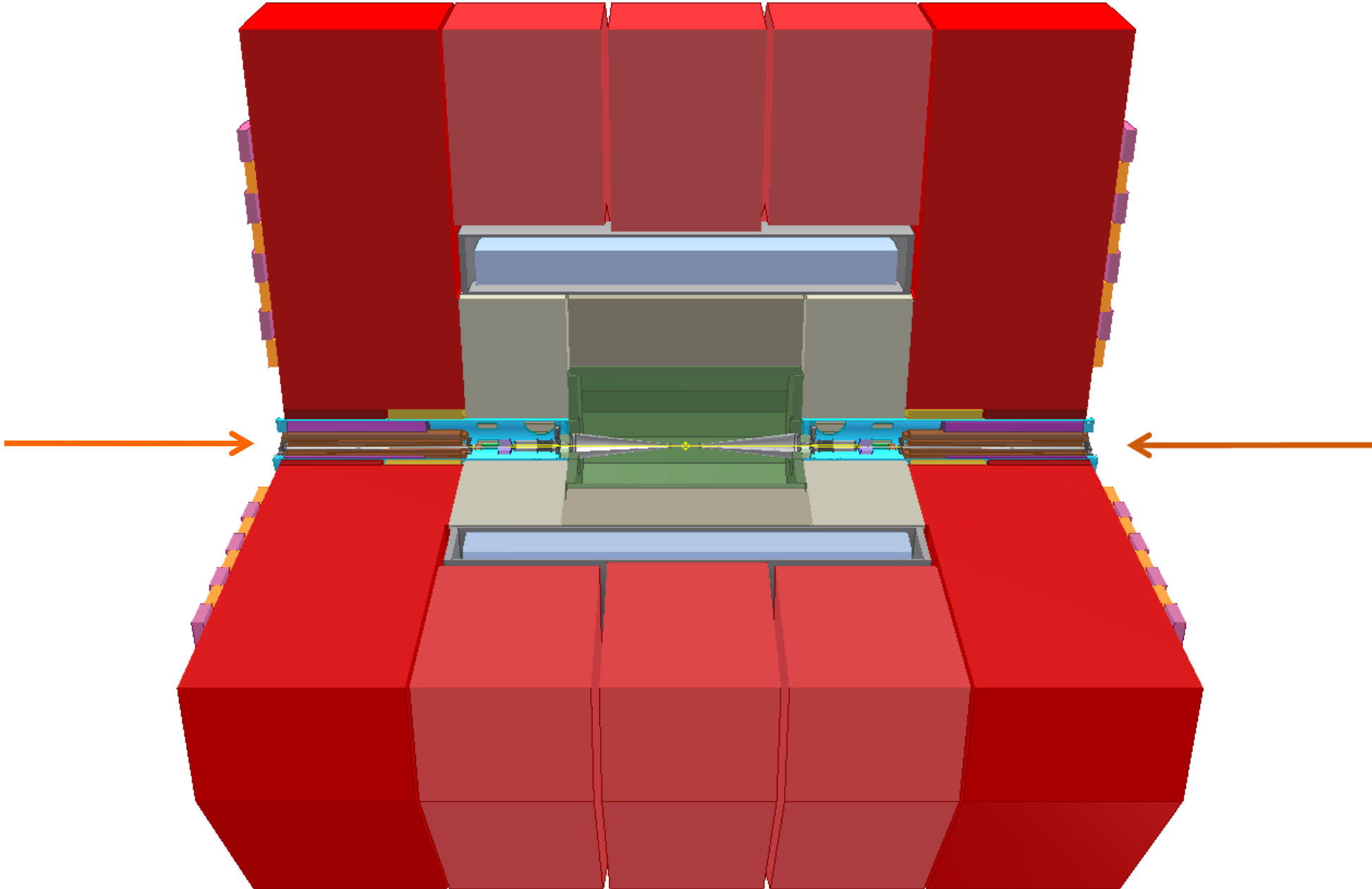

# MACHINE DETECTOR INTERFACE

Plus others .....

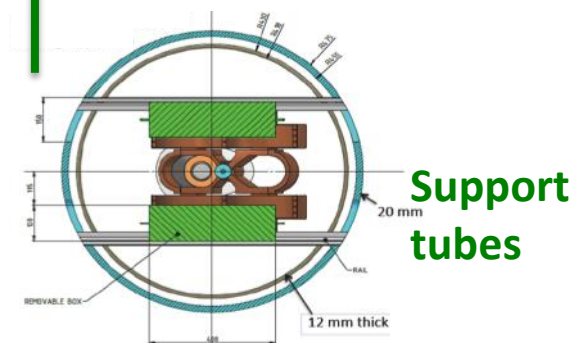
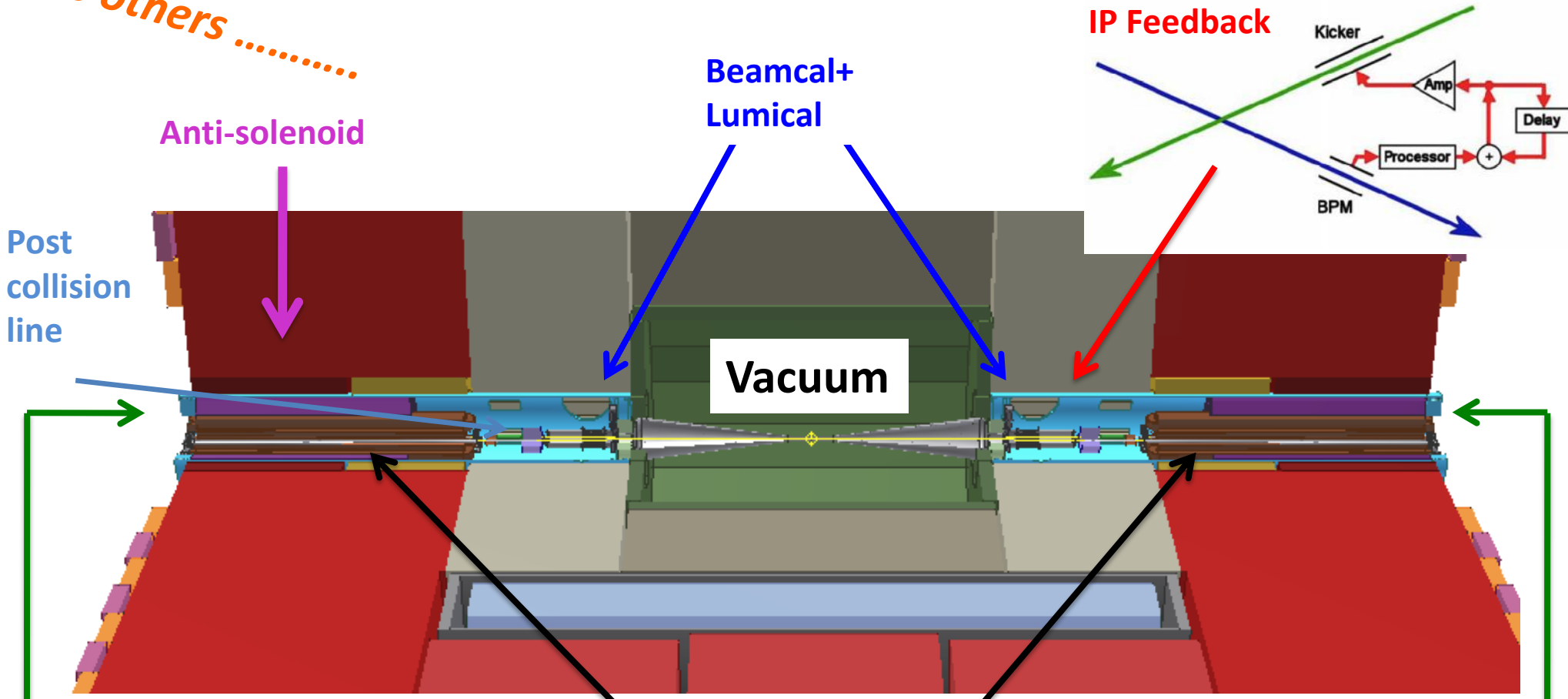

Support tubes

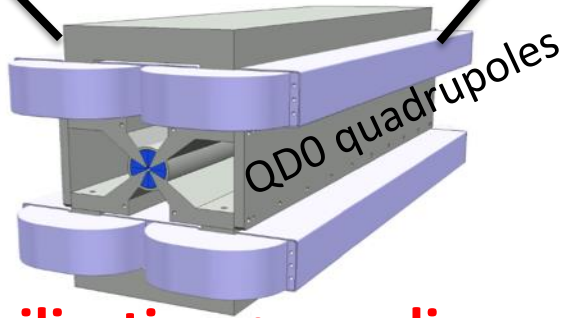

+Stabilization + prealignment

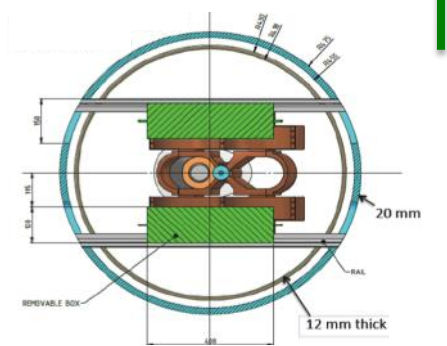



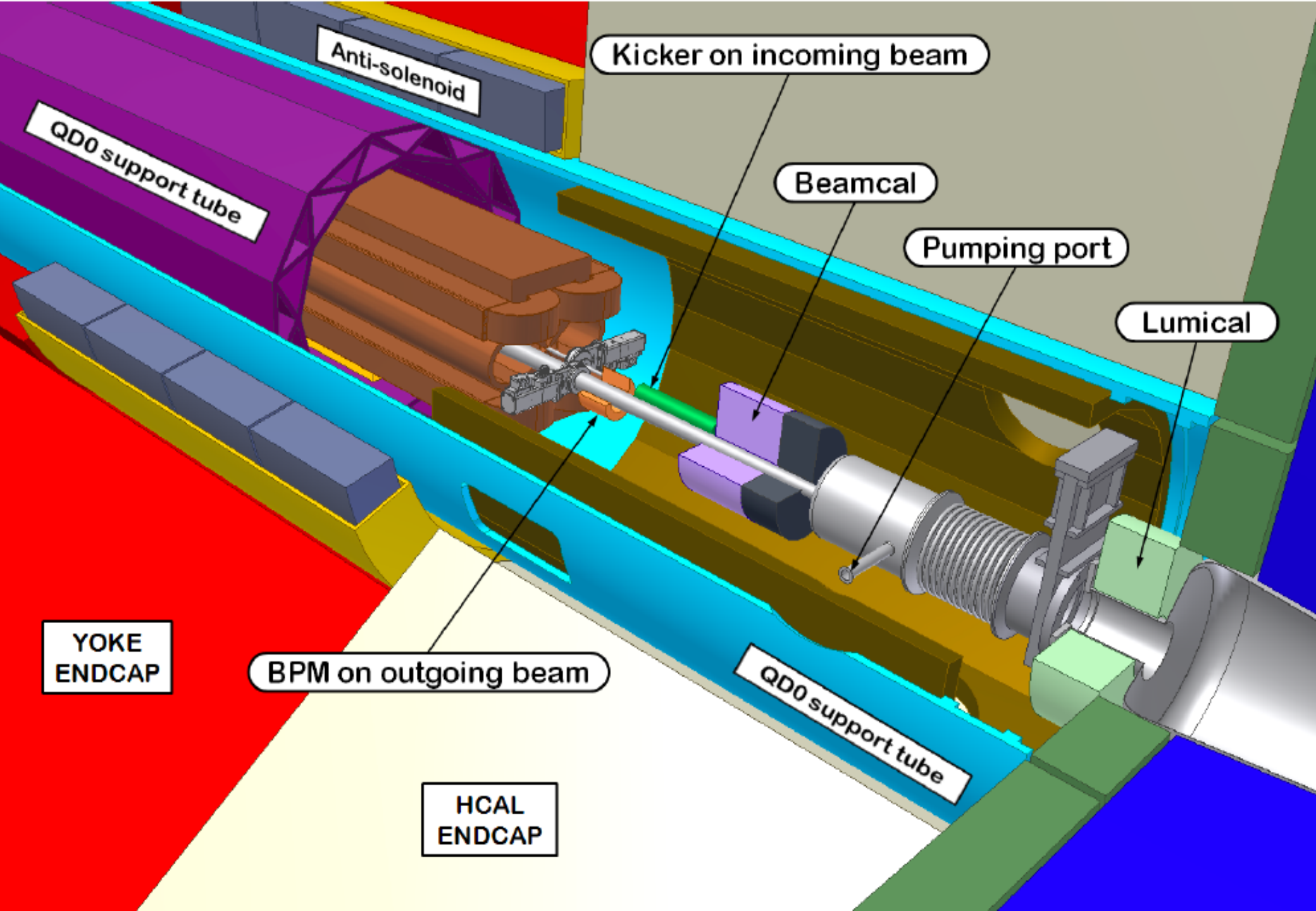

Anti-solenoid

Kicker on incoming beam

QD0 support tube

Beamcal

Pumping port

Lumical

YOKE ENDCAP

BPM on outgoing beam

QD0 support tube

HCAL ENDCAP

- Introduction
- **QD0 prototype measurements**
- QD0 pre-alignment
- QD0 stabilisation
- IP feedback
- Anti-solenoid compensation
- Post-collision line (back to MDI since 2012)
- Coming soon: study option with QD0 in tunnel

# QD0 study & design requirements

<i>QD0 Baseline Parameter</i>	<i>Value</i>
Nominal target for field gradient	575 T/m
Magnetic length	2.73 m
Magnet aperture (required for beam)	7.6 mm
Magnet bore diameter	8.25 mm* <i>* Including a 0.30 mm vacuum chamber thickness</i>
Good field region (GFR) radius	1 mm
Integrated field gradient error inside GFR	< 0.1%
Gradient adjustment	+0 to -20%

## Magnet design boundary conditions:

- As much as possible **compact design** (to be compatible with an  $L^*$  of 3.5 m, so minimizing the solid angle subtracted to the experiment Detector)
- Compatible with **magnet active stabilization** (i.e. minimize magnet weight and vibration sources, ex. coil water cooling)
- Presence of the **post-collision line beam vacuum chamber** (in its closer position at 35 mm from beam axis)



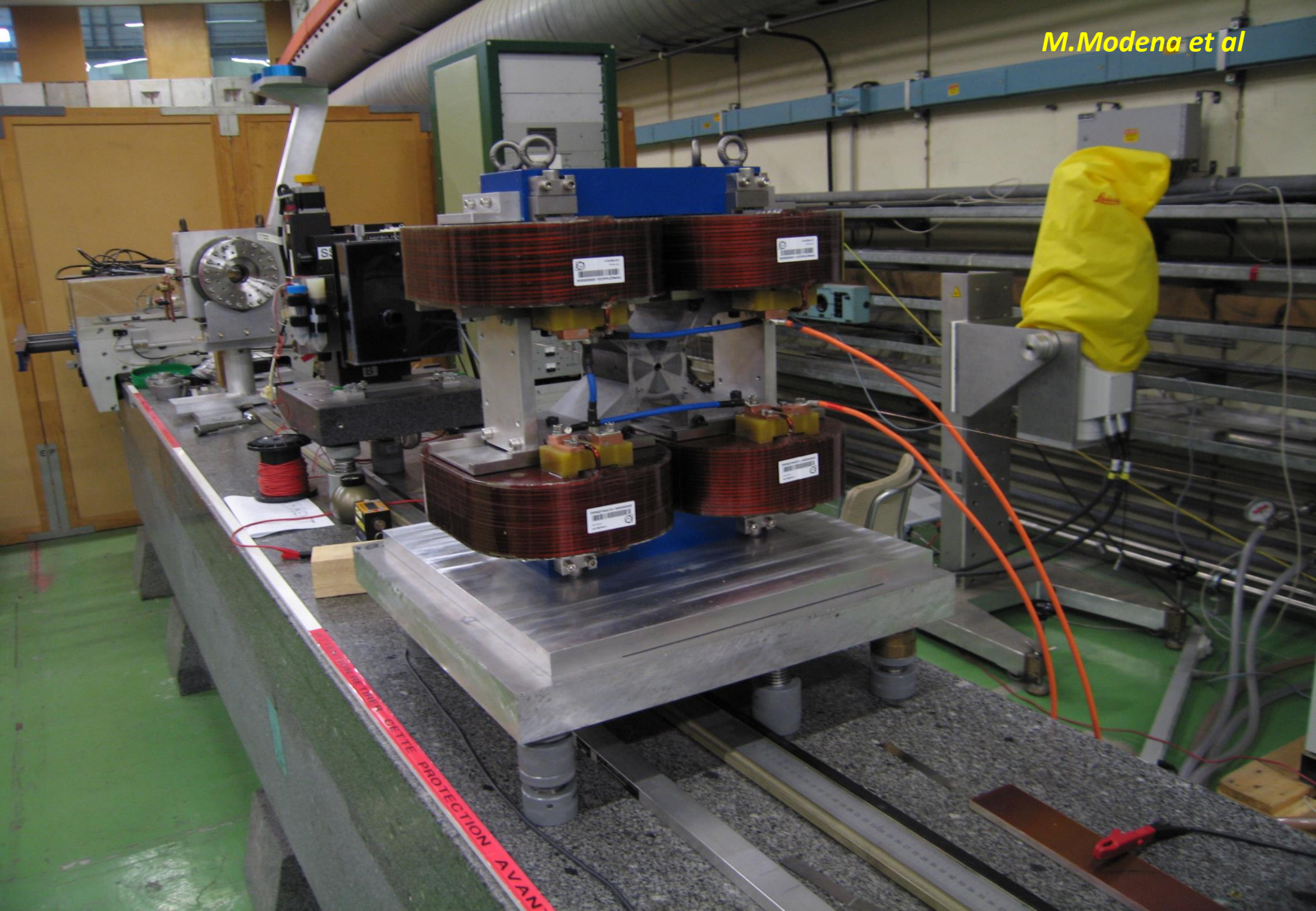



# The "Single Stretched Wire" and "Rotated Vibrating Wire" MM System

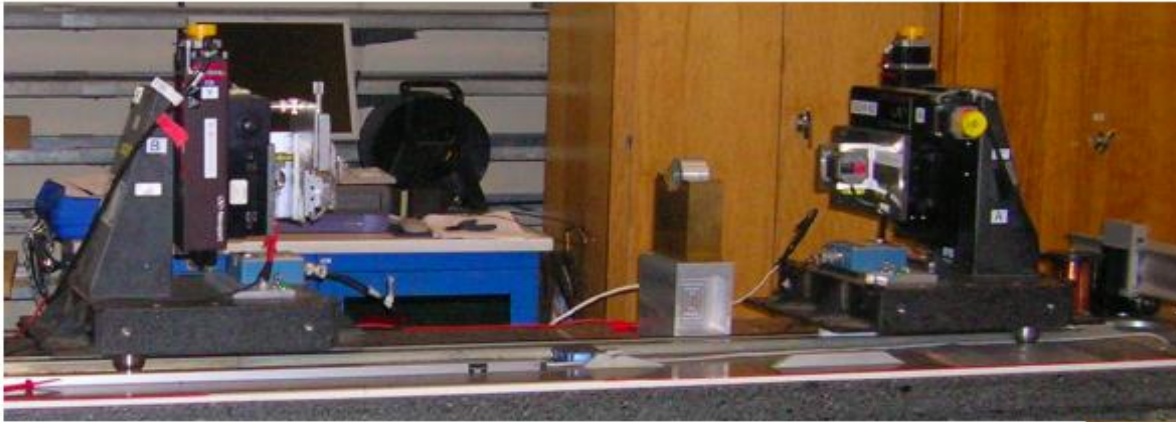

## Optical sensor linearization



23/03 Measurement setup

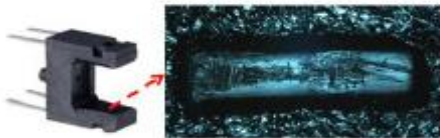

GAP 3 mm, Slit 0.3 mm

Scratched surface: nonlinear response

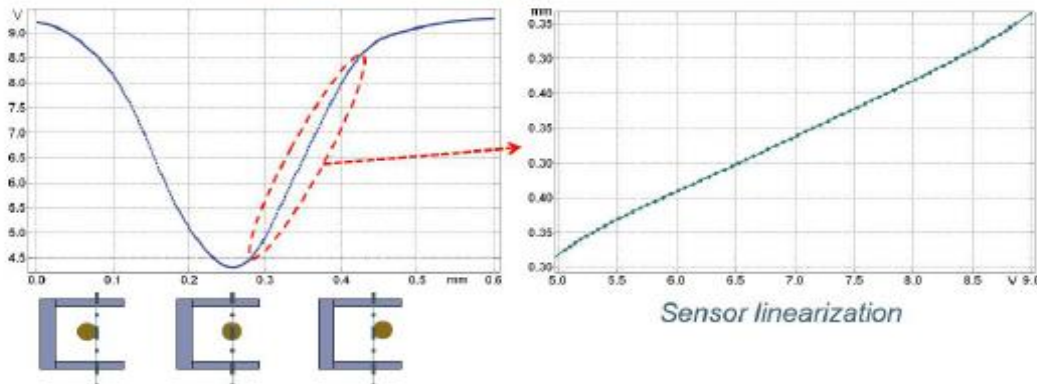

**Two** campaign of measurements were done in 2012 with QD0 prototype in two different configuration:  
 - in January 2012: the magnet equipped with the  $\text{Nd}_2\text{Fe}_{14}\text{B}$  blocks was measured with the Vibrating wire system  
 - in August 2012: the same type of measurement was done for the configuration with  $\text{Sm}_2\text{Co}_{17}$  blocks .

Here below are shown the measurements of the MEASURED Gradient (red dots) (extrapolated from the INTEGRATED GRADIENT effectively measured), together with the COMPUTED Gradient (blue curves).

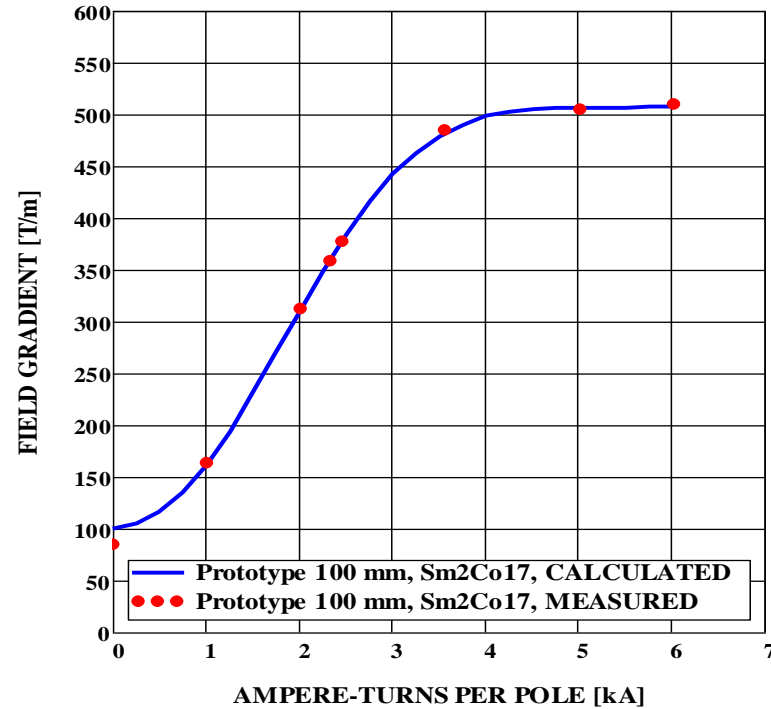
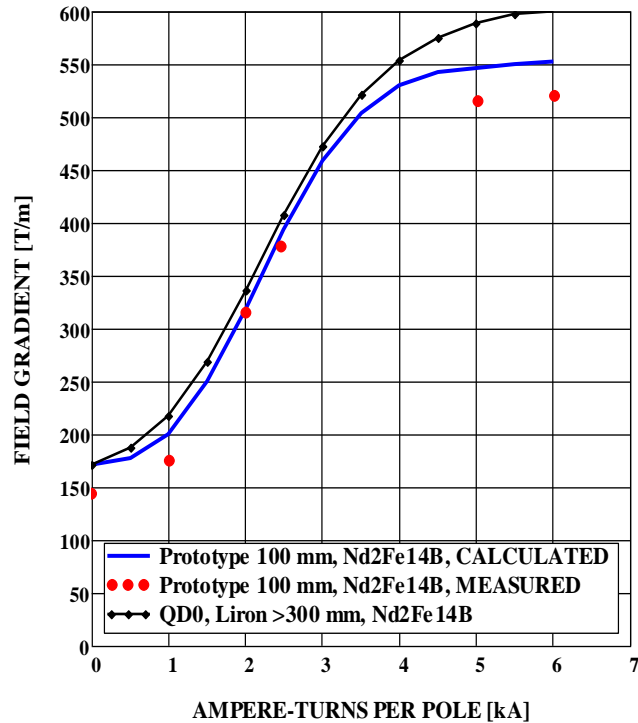

The measured Gradient in the configuration with  $\text{Sm}_2\text{Co}_{17}$  blocks it is in very good agreement with the FEA computation. This is not the case for the  $\text{Nd}_2\text{Fe}_{14}\text{B}$  blocks were a difference of  $\sim -6\%$  is visible. This could have 2 possible explanation but the 1<sup>st</sup> was then excluded by a 2<sup>nd</sup> FEA cross-check:

-The Permendur saturate at lower level than expected. → The magnetization curve extracted from the Test Report of the raw material provided by the Supplier was utilized for the FEA computation that confirm that the problem is not coming by the Permendur quality.

-The quality (magnetization module and/or direction) of the  $\text{Nd}_2\text{Fe}_{14}\text{B}$  PM blocks is not the expected one → we should get more indication of this possibility when the PM blocks measuring device (by Helmholtz coils) will be delivery to the MM Section.

## 2. Preliminary considerations for CLIC SDO sextupole design:

*“Closed yoke” version:*

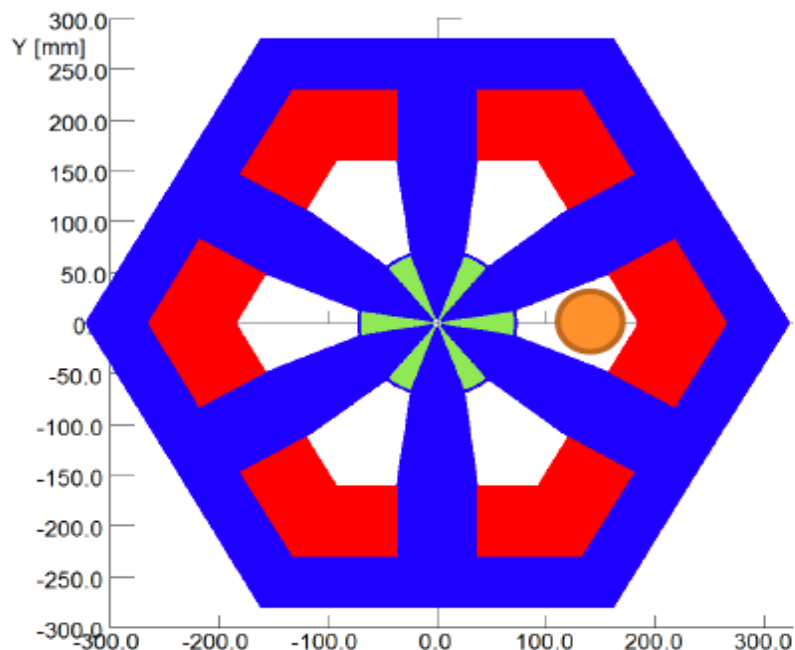



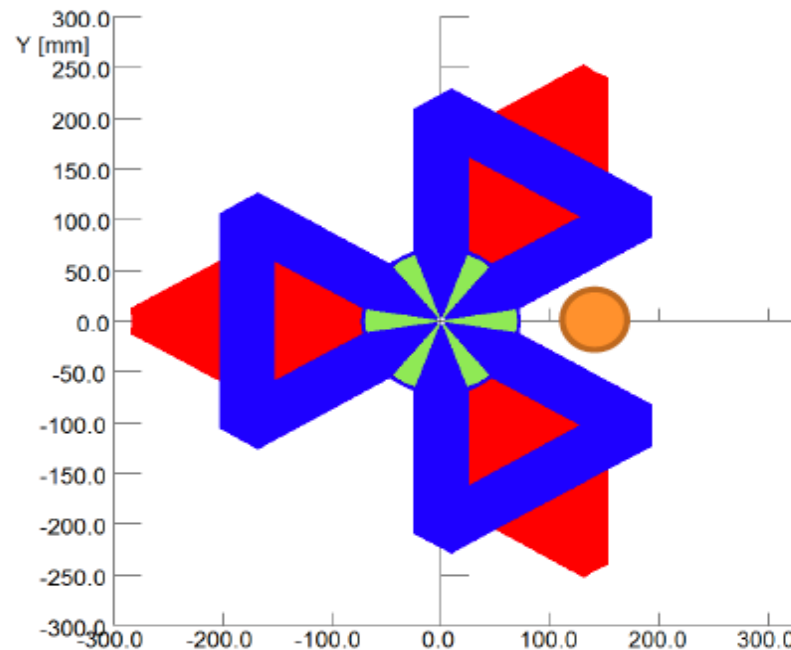

*“Open yoke” version:*



### **Main parameters:**

Aperture (radius):	4.3 mm
Max. Achievable	
Sextupole gradient:	220 000 T/m <sup>2</sup>
Magnetic length	250 mm
Amperturns NI	5300 Amps

-  Coils
-  1010 steel yoke
-  Permanent magnet blocks (NdFeB)
-  Post-collision line

*See talk by M.Modena  
on Thursday afternoon*

- Introduction
- QD0 prototype measurements
- **QD0 pre-alignment**
- QD0 stabilisation
- IP feedback
- Anti-solenoid compensation
- Post-collision line (back to MDI since 2012)
- Coming soon: study option with QD0 in tunnel



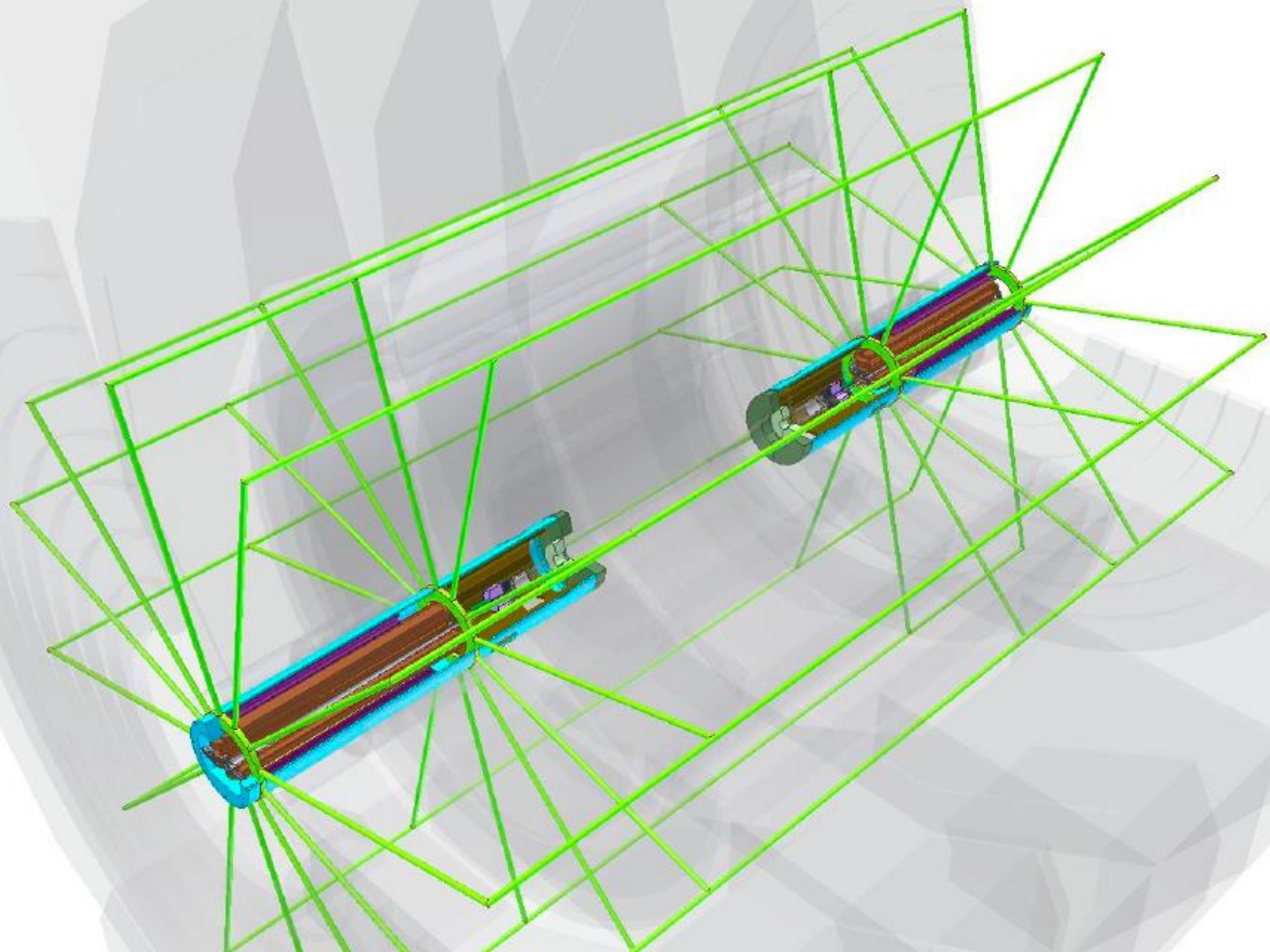

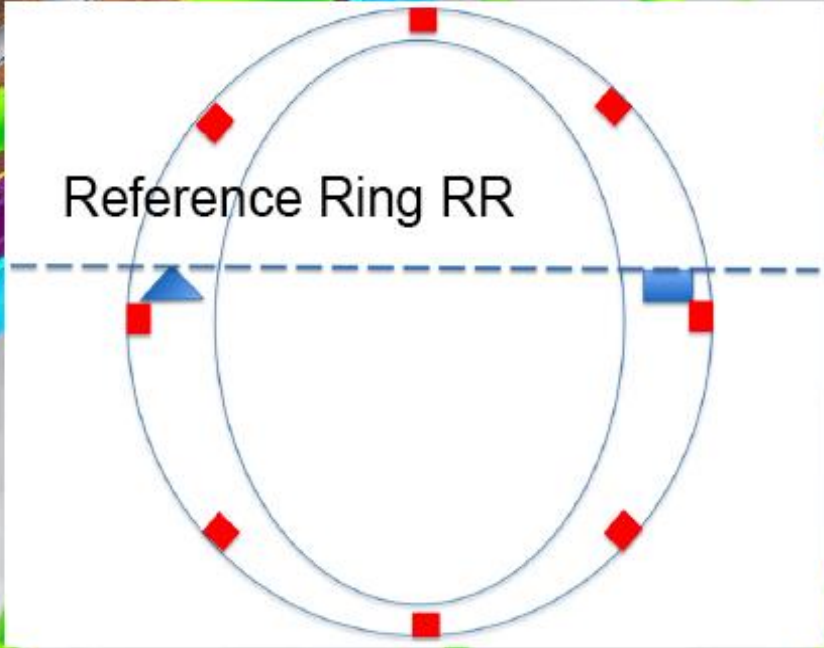
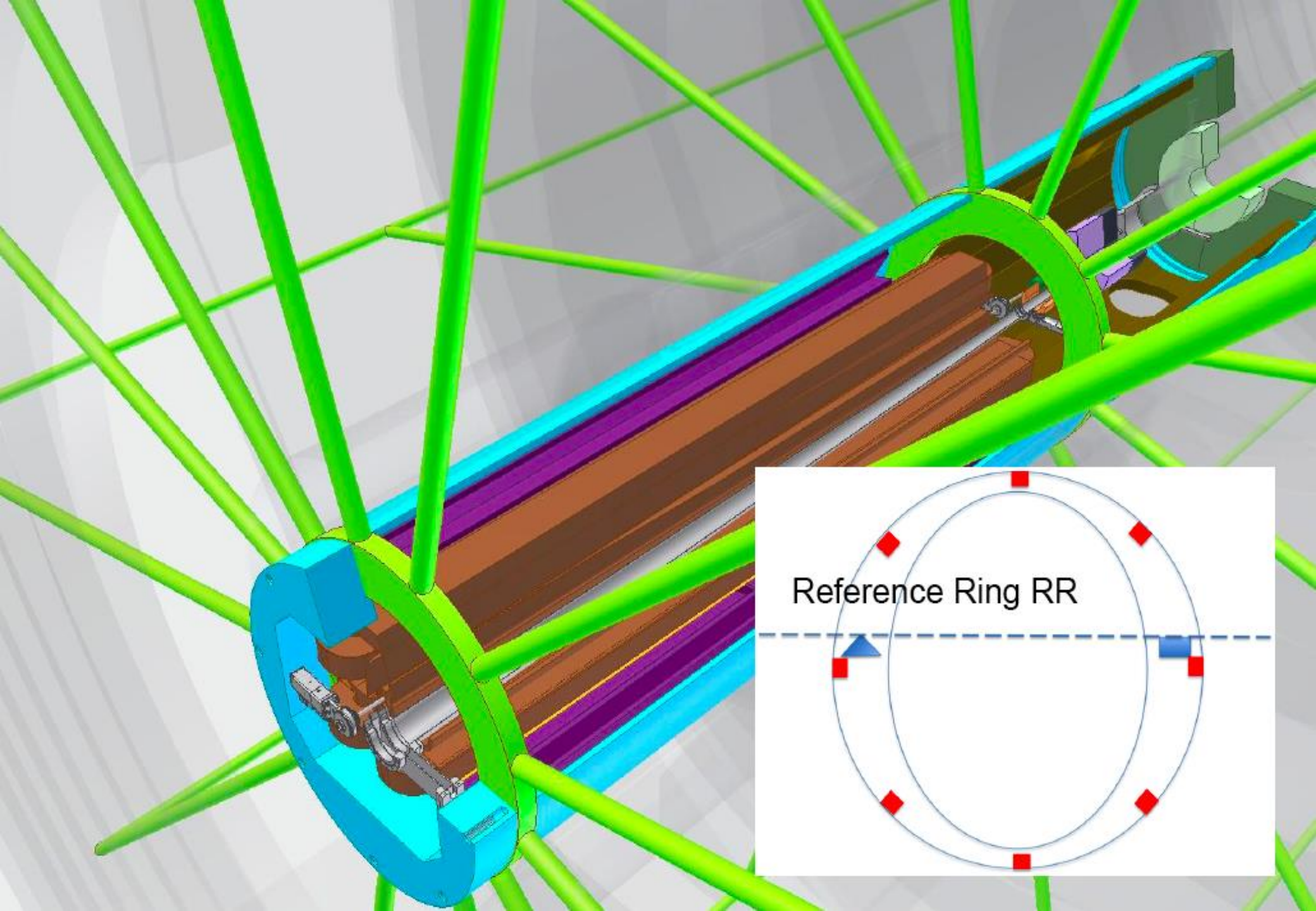



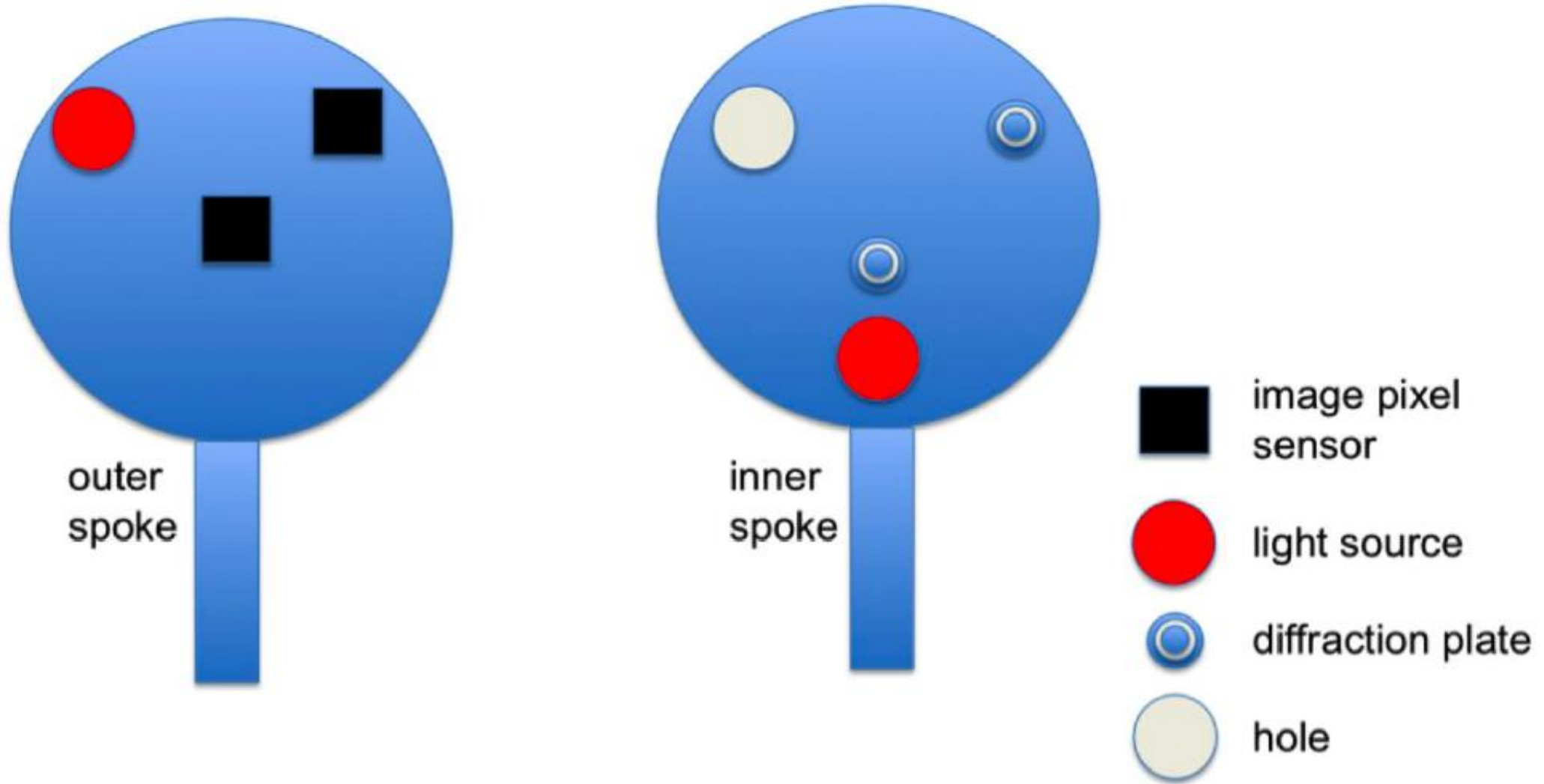



1 m spoke raw data; 6 mm spring clearance

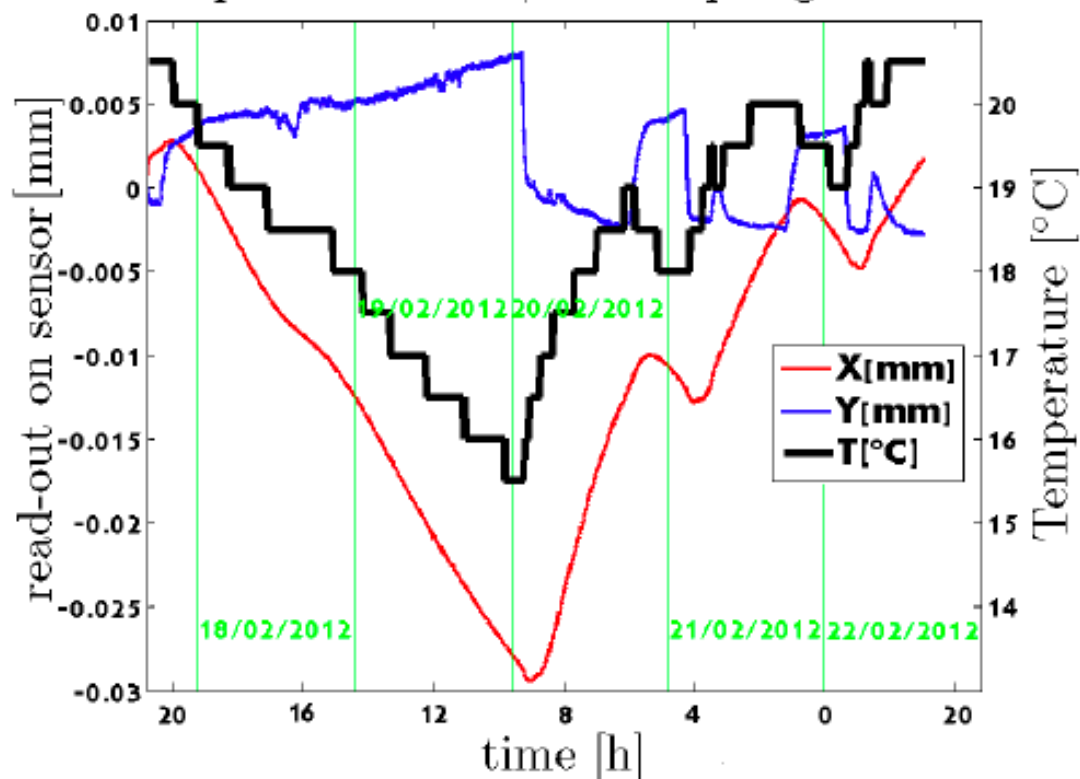
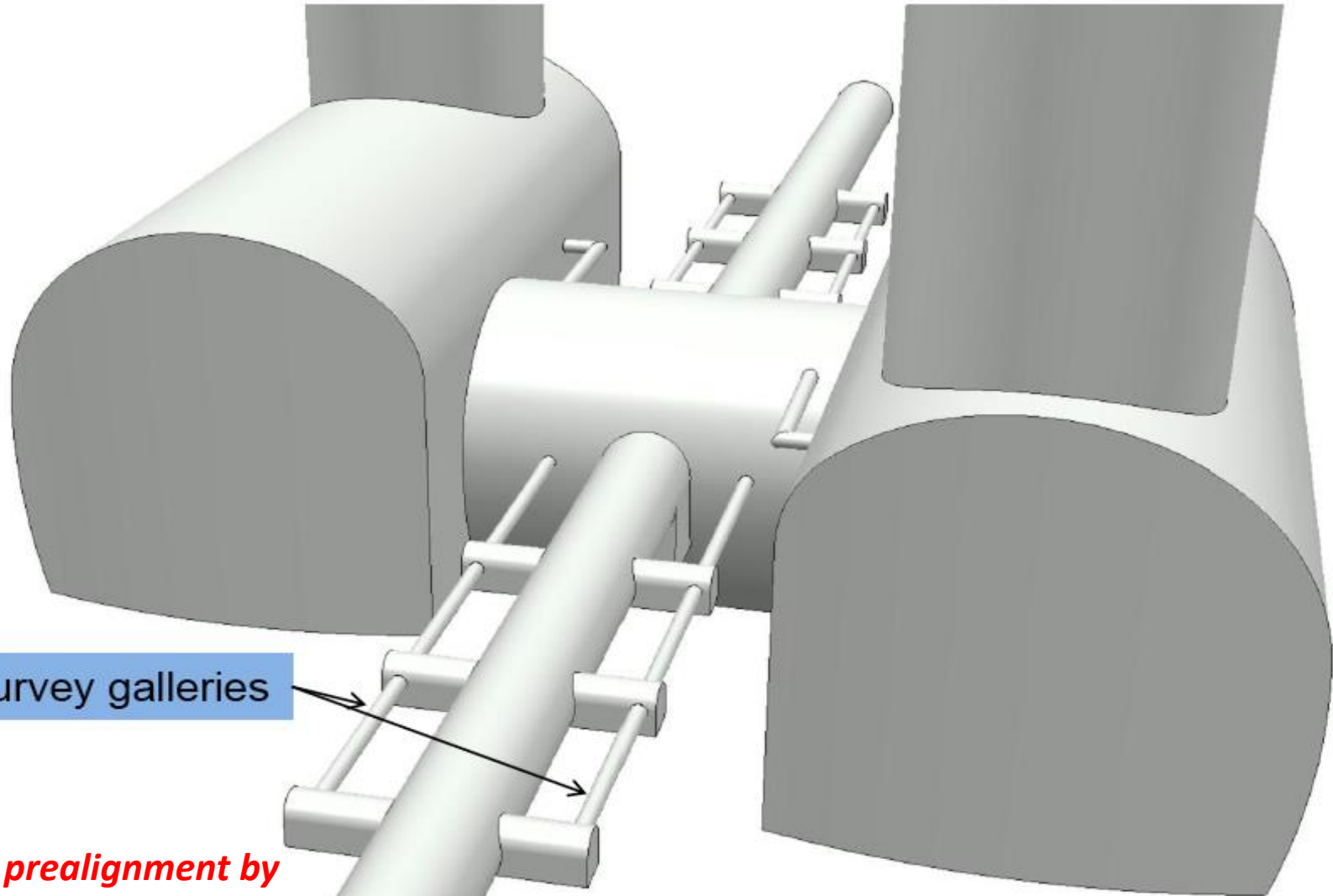

Figure 7.10: 4 day Rasnik measurement of the expansion of granite table and temperature. The x coordinate is in the length direction of the 1 m Zerodur spoke

# MDI area - proposed survey channels



Mini survey galleries

*See talk on prealignment by  
H.Mainaud Durand on Thursday afternoon*



- Introduction
- QD0 prototype measurements
- QD0 pre-alignment
- **QD0 stabilisation**
- IP feedback
- Anti-solenoid compensation
- Post-collision line (back to MDI since 2012)
- Coming soon: study option with QD0 in tunnel

-Active foot:

Lower electrode of  
the capacitive  
sensor

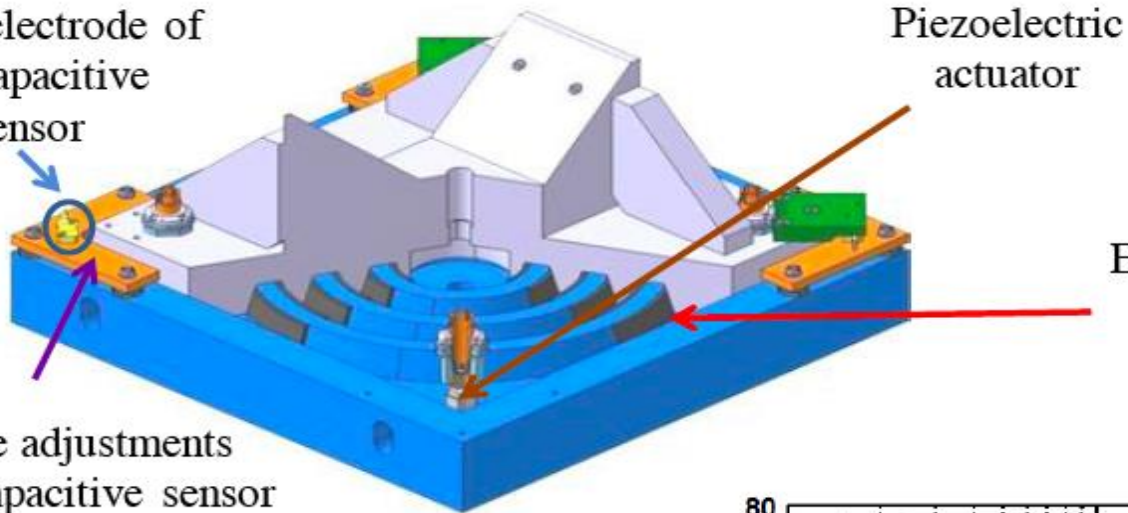

Elastomeric strips  
for guidance

Fine adjustments  
for capacitive sensor  
(tilt and distance)

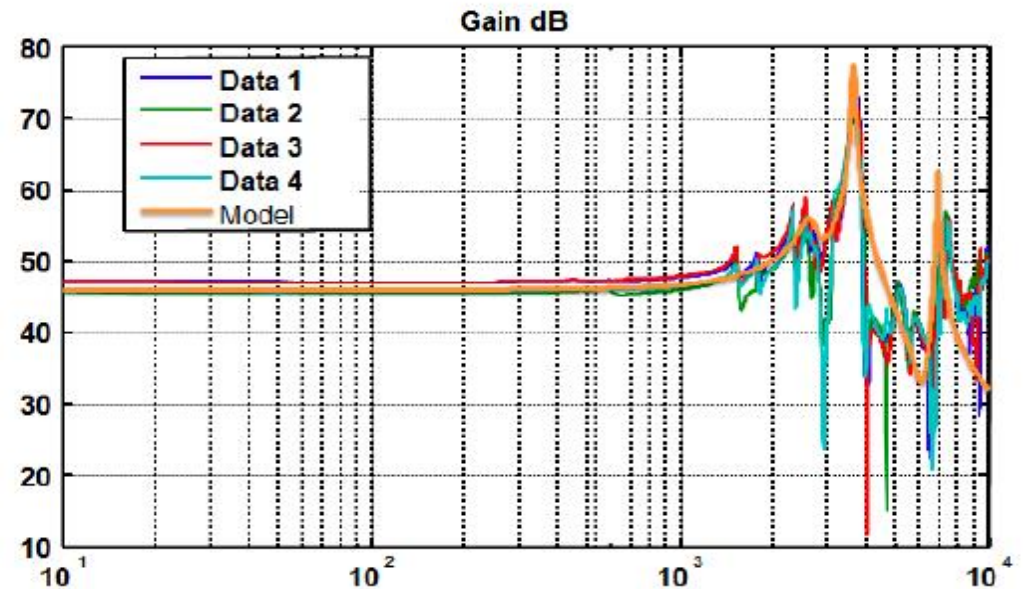
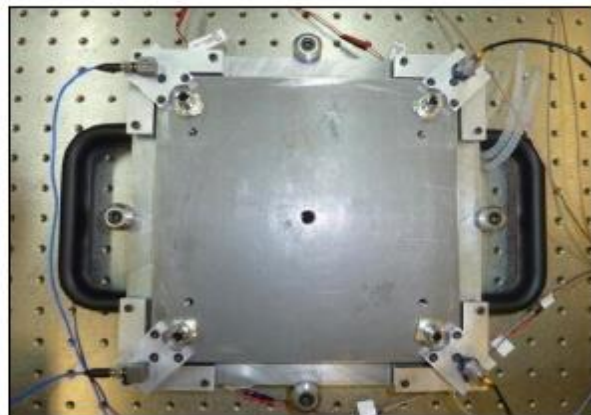

# Mechanical active stabilisation – experimental setup

- Control architecture :



Matlab and dSPACE ControlDesk  
For monitoring and analysis



- Used sensors :
  - Geophones : GURALP CMG-6T
  - Accelerometers : WILCOXON 731A



Amplifiers, filters input/output board  
for signal conditioning



dSPACE  
Real time hardware for  
Rapid Control Prototyping



✓ All is taken into account in simulation (noise, ADC, DAC...).

## Mechanical active stabilisation – Results

- *Simulation and experimental results (RMS) :*

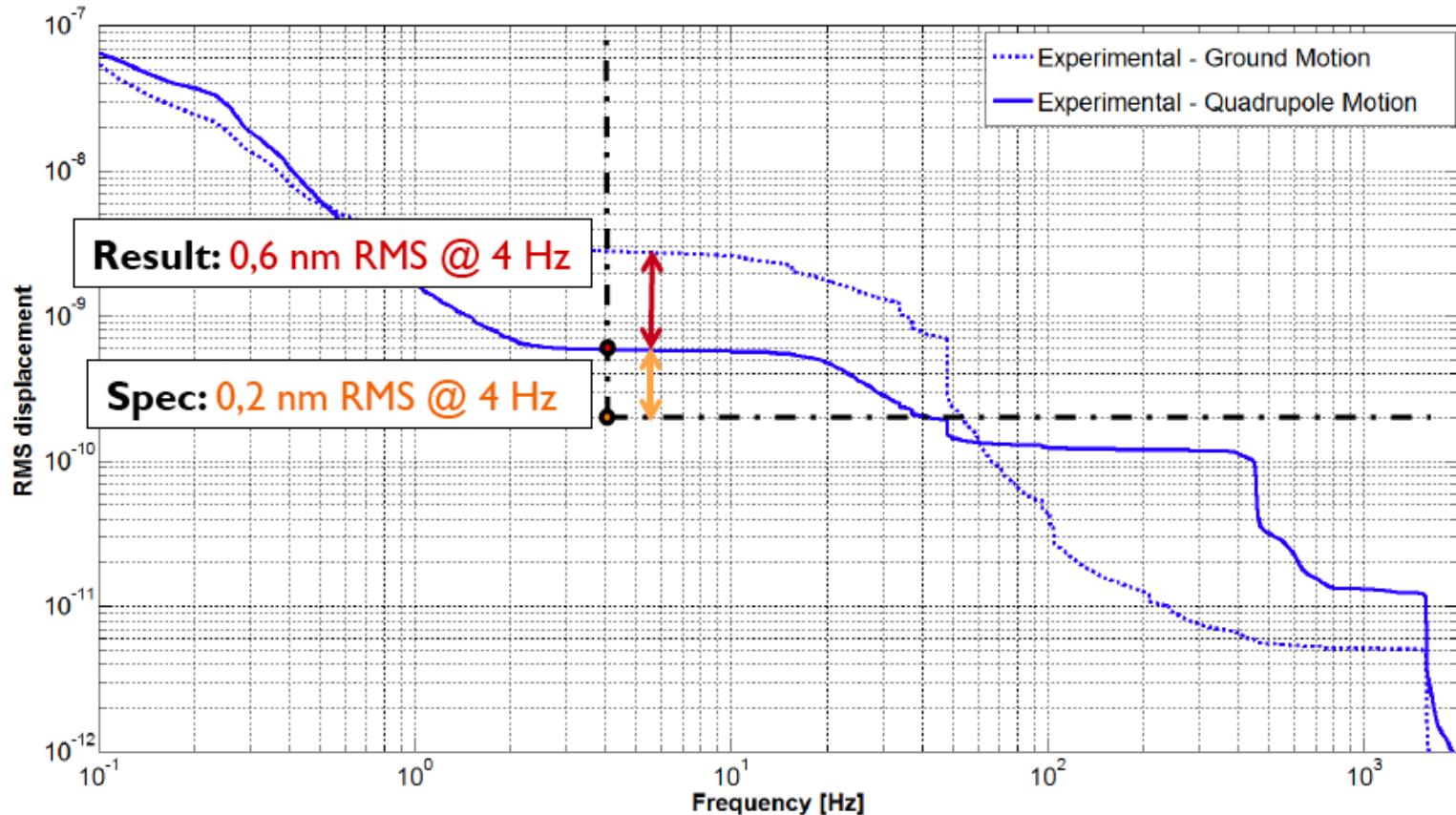

- **Publication in progress (accepted) : Balik et al, “Active control of a subnanometer isolator“, JIMMSS.**



## New development

### Dummy QD0 magnet stabilization

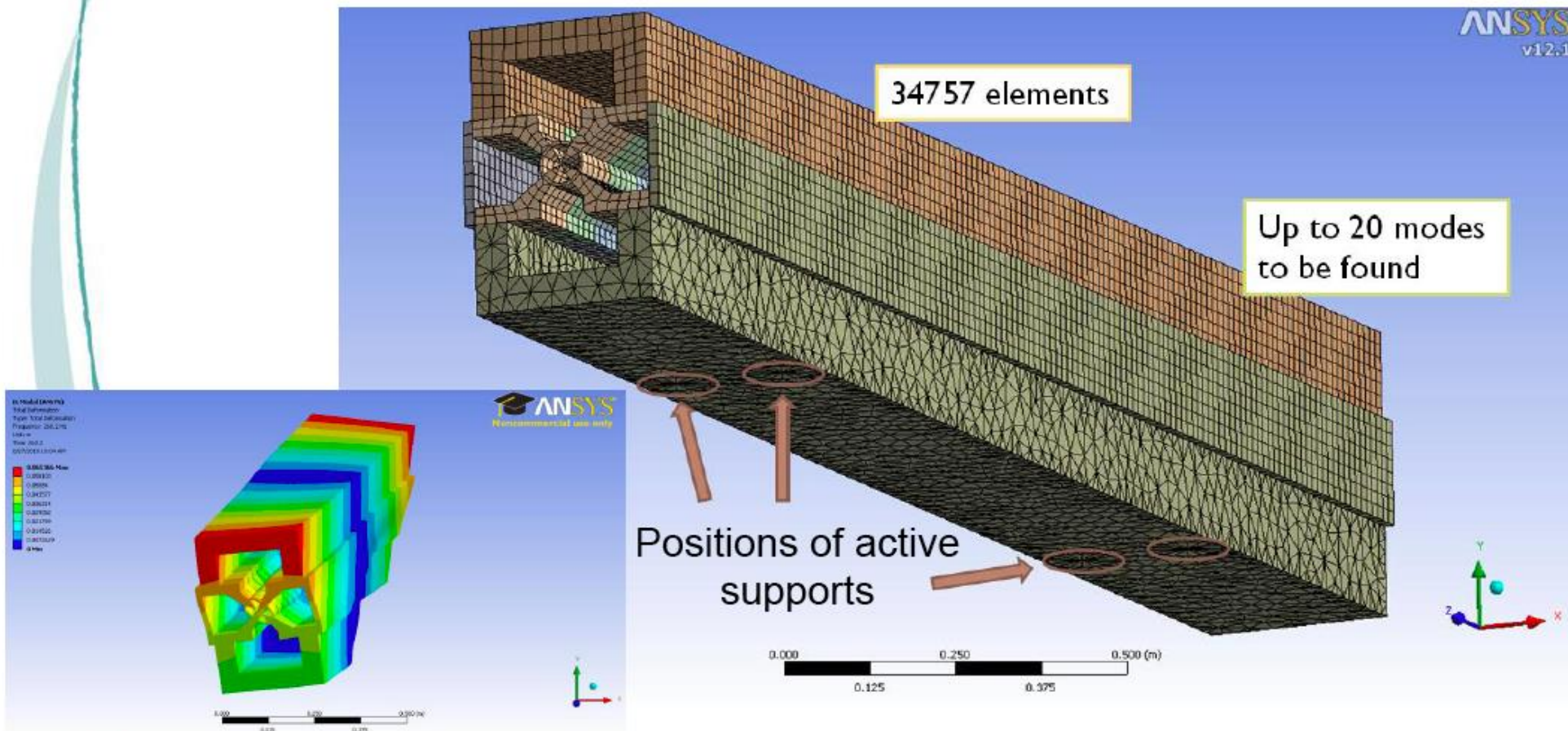

- QD0 Model Ansys-> Matlab ->simulink
- Multi-support simulation -> demonstrator



# Finite element model (Full scale)

9

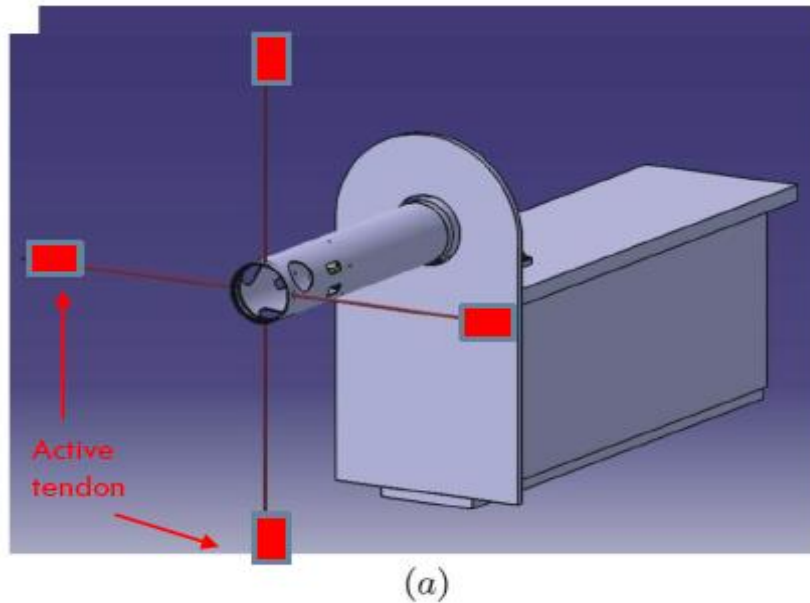

$$\begin{cases} k_{cable} = 6.7 \cdot 10^7 \text{ N/m} \\ L_{cable} = 3.32 \text{ m} \\ d_{cable} = 39.64 \text{ mm} \\ E_{cable} = 180 \text{ Gpa} \end{cases}$$

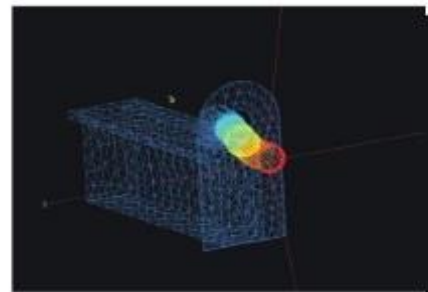
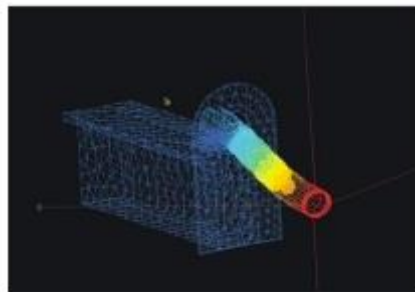

Resonances  
frequencies  
multiplied by 2

←

**Q: Where to fix the cables?**

# Numerical results

10

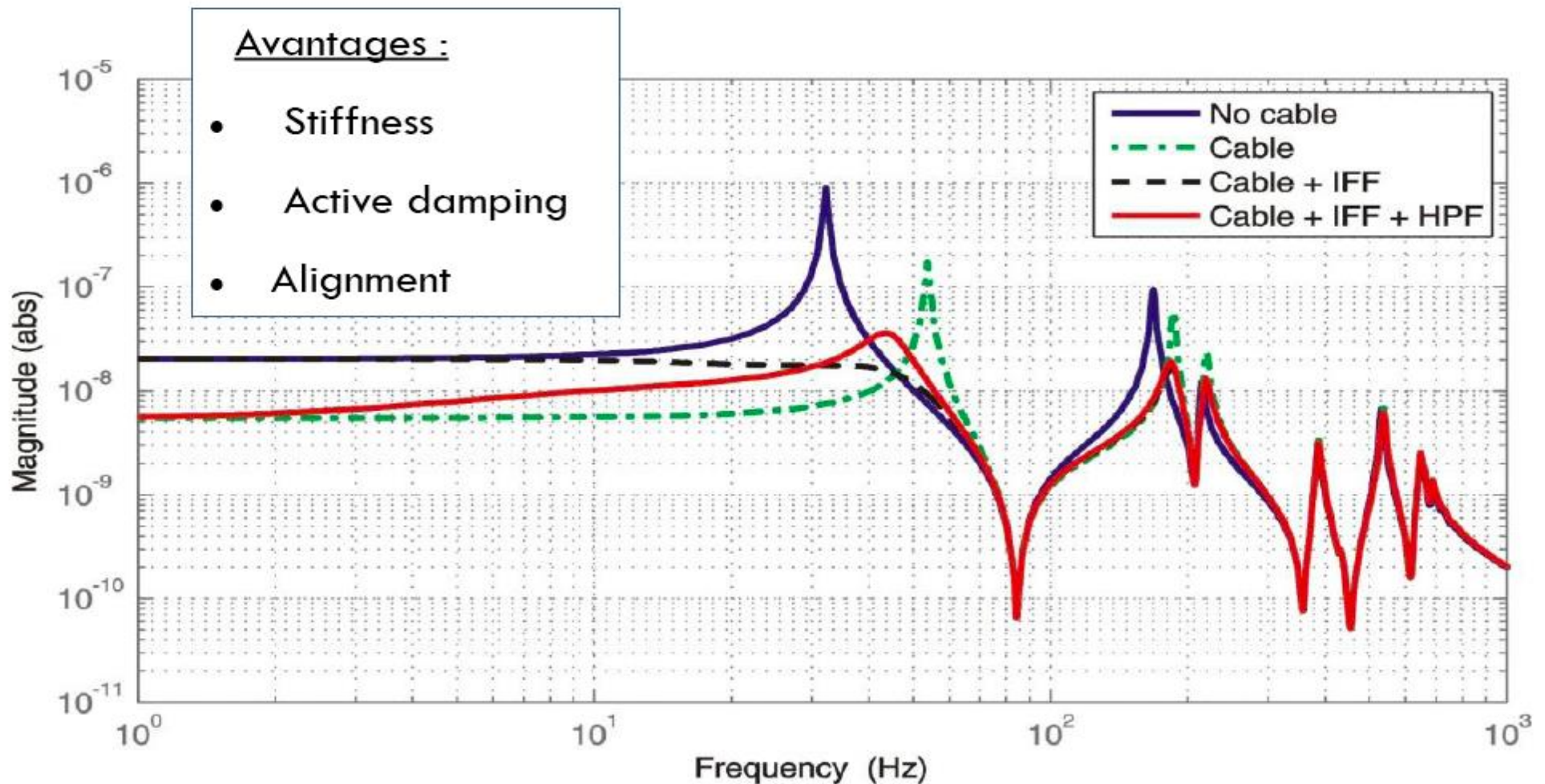

# Experimental set-up

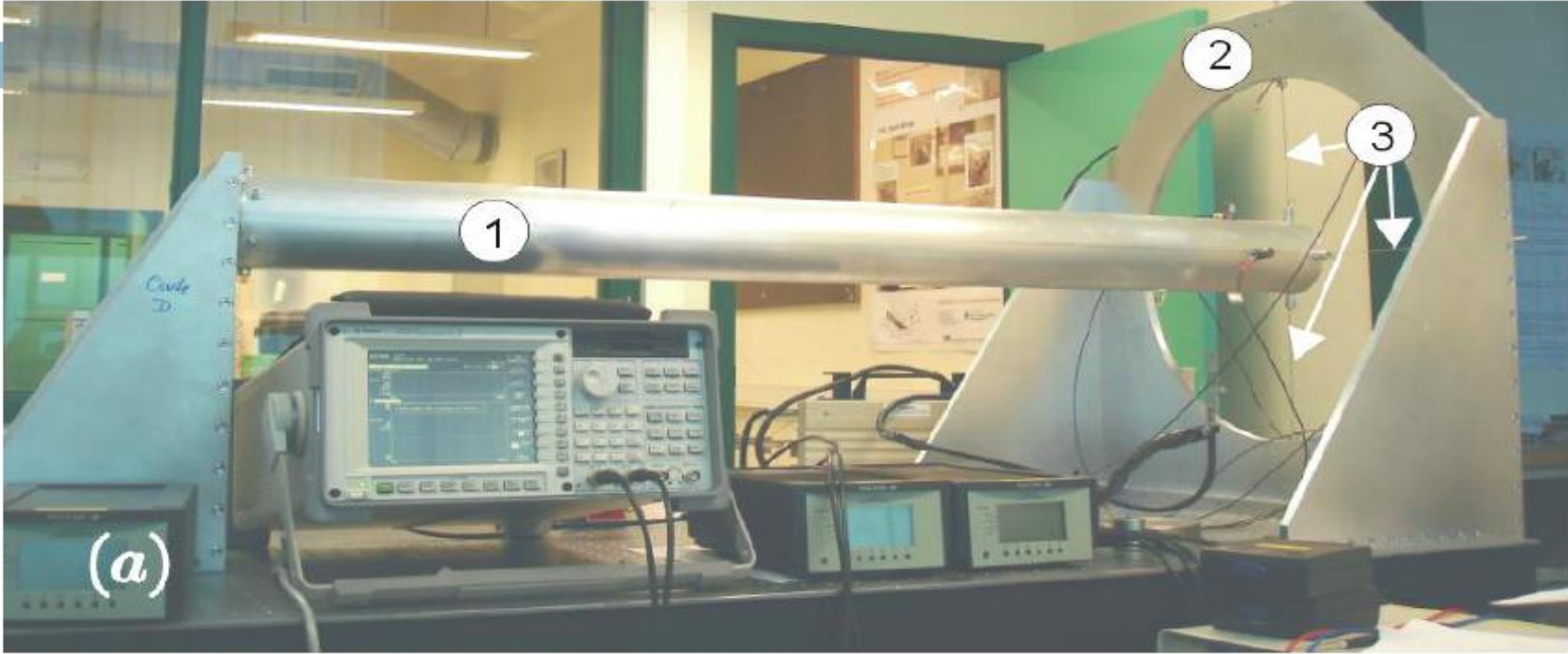

- 1. Cantilevered tube  
(corresp. to flexible structure)
- 2. Rigid frame
- 3. Carbon cables  
(corresp. to carbon tie rods)
- 4. Piezoelectric actuator
- 5. Force sensor
- 6. Dedicated fixation/tension system

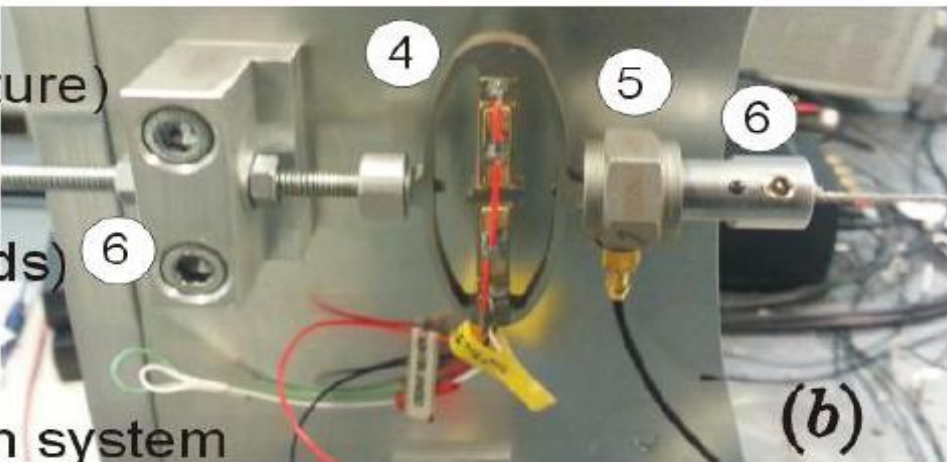

- Introduction
- QD0 prototype measurements
- QD0 pre-alignment
- QD0 stabilisation
- **IP feedback**
- Anti-solenoid compensation
- Post-collision line (back to MDI since 2012)
- Coming soon: study option with QD0 in tunnel



# LC intra-train feedback system - concept

Last line of defence  
against relative beam  
misalignment

Measure vertical position  
of outgoing beam and  
hence beam-beam  
kick angle

Use fast amplifier and  
kicker to correct  
vertical position of  
beam incoming to IR

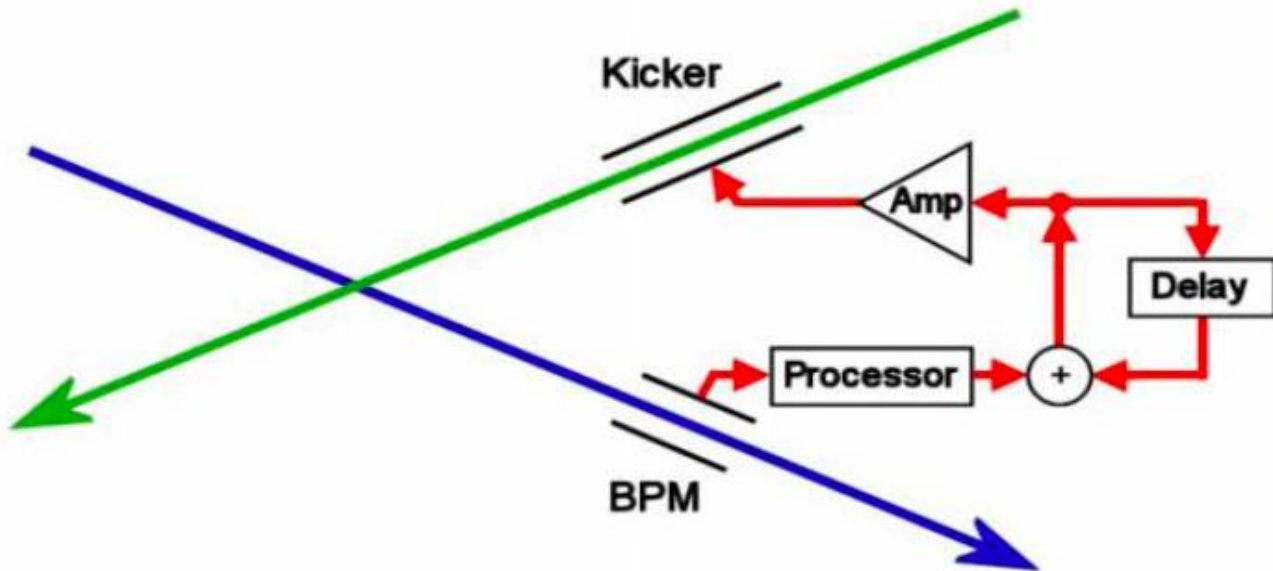

**FONT – Feedback On Nanosecond Timescales**



# IP FB Design Status: CLIC

---

**Conceptual design developed and documented in CLIC CDR (2011)**

**NB primary method for control of beam collision overlap is via vibration isolation of the FF magnets, and dynamic correction of residual component motions**

**IP position feedback:**

**allows IP beam position correction of  $\pm 50$  nm of vertical beam motion, and possibility to correct within bunchtrain duration**

**More realistic engineering design can be developed in next project phase**

# CLIC prototype: FONT3 at KEK/ATF



*See talk by Ph.Burrows  
on Wednesday morning*

**BPM resolution ~ 1 $\mu$ m  
Latency ~ 23ns  
Drive power > +/-50nm @ CLIC**

- Introduction
- QD0 prototype measurements
- QD0 pre-alignment
- QD0 stabilisation
- IP feedback
- **Anti-solenoid compensation**
- Post-collision line (back to MDI since 2012)
- Coming soon: study option with QD0 in tunnel





# Residual field (BZ) inside QD0

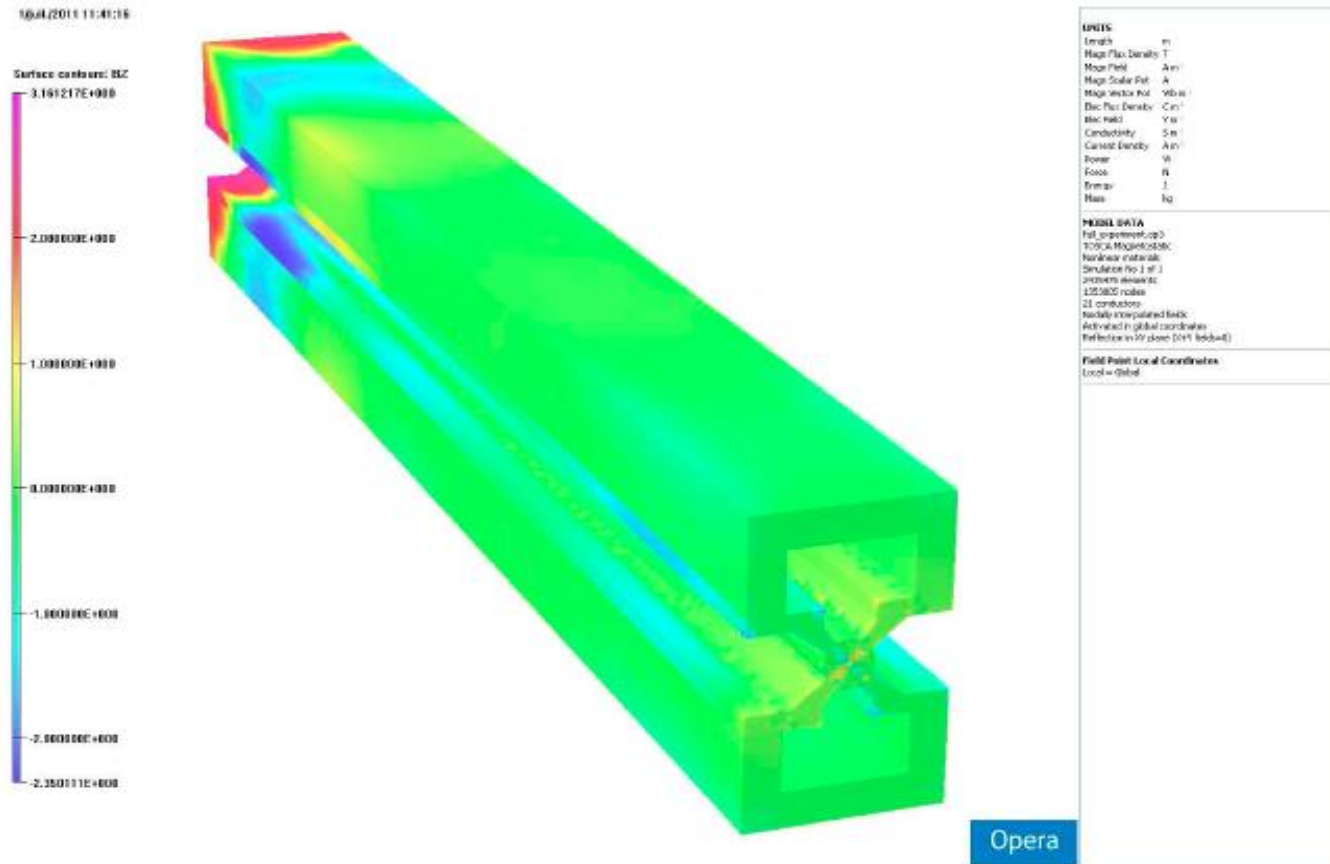

Excellent performance of anti-solenoid,  
still some issues at the QD0 extremity



# Main improvements

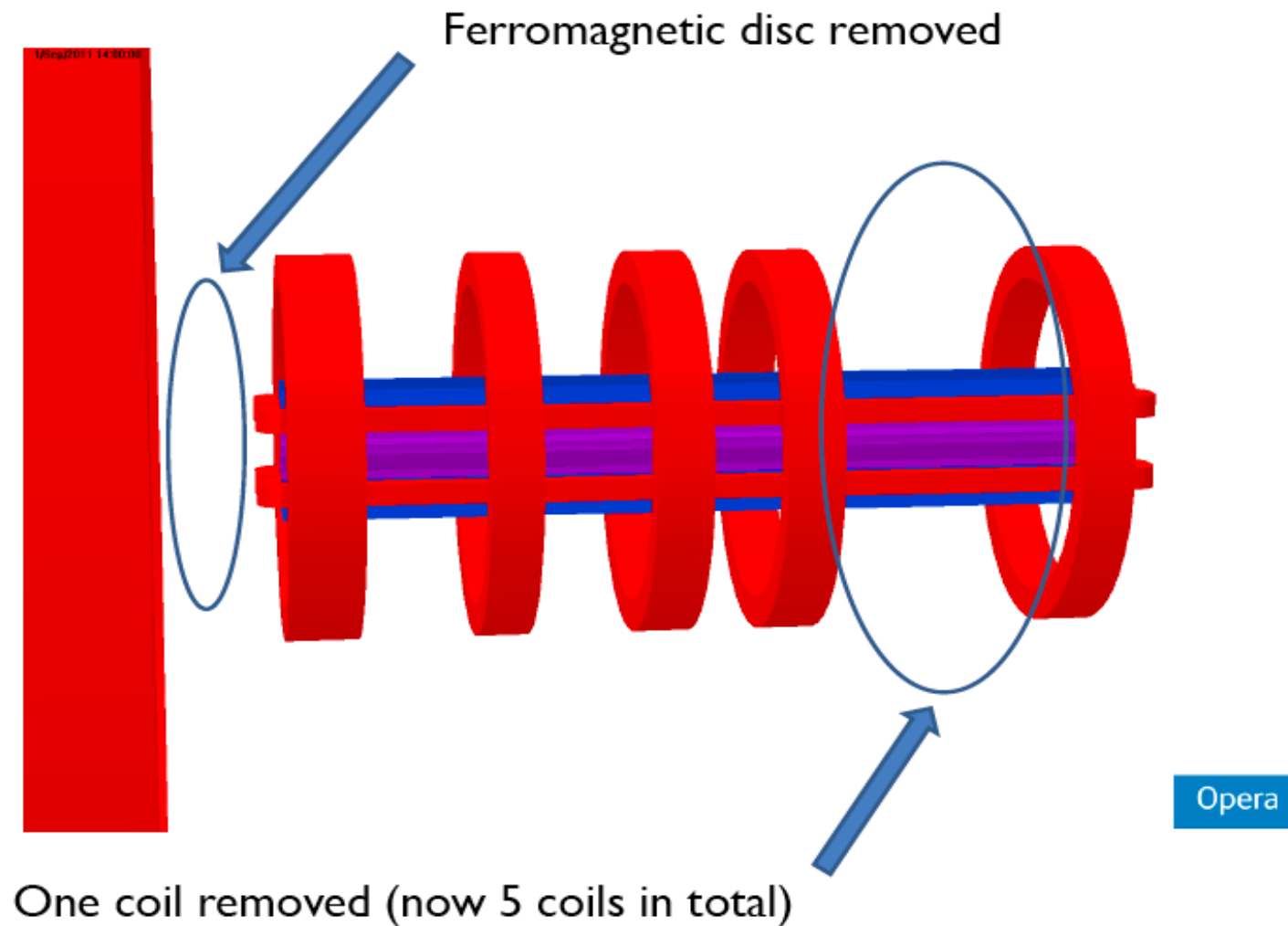



# Field maps – BZ

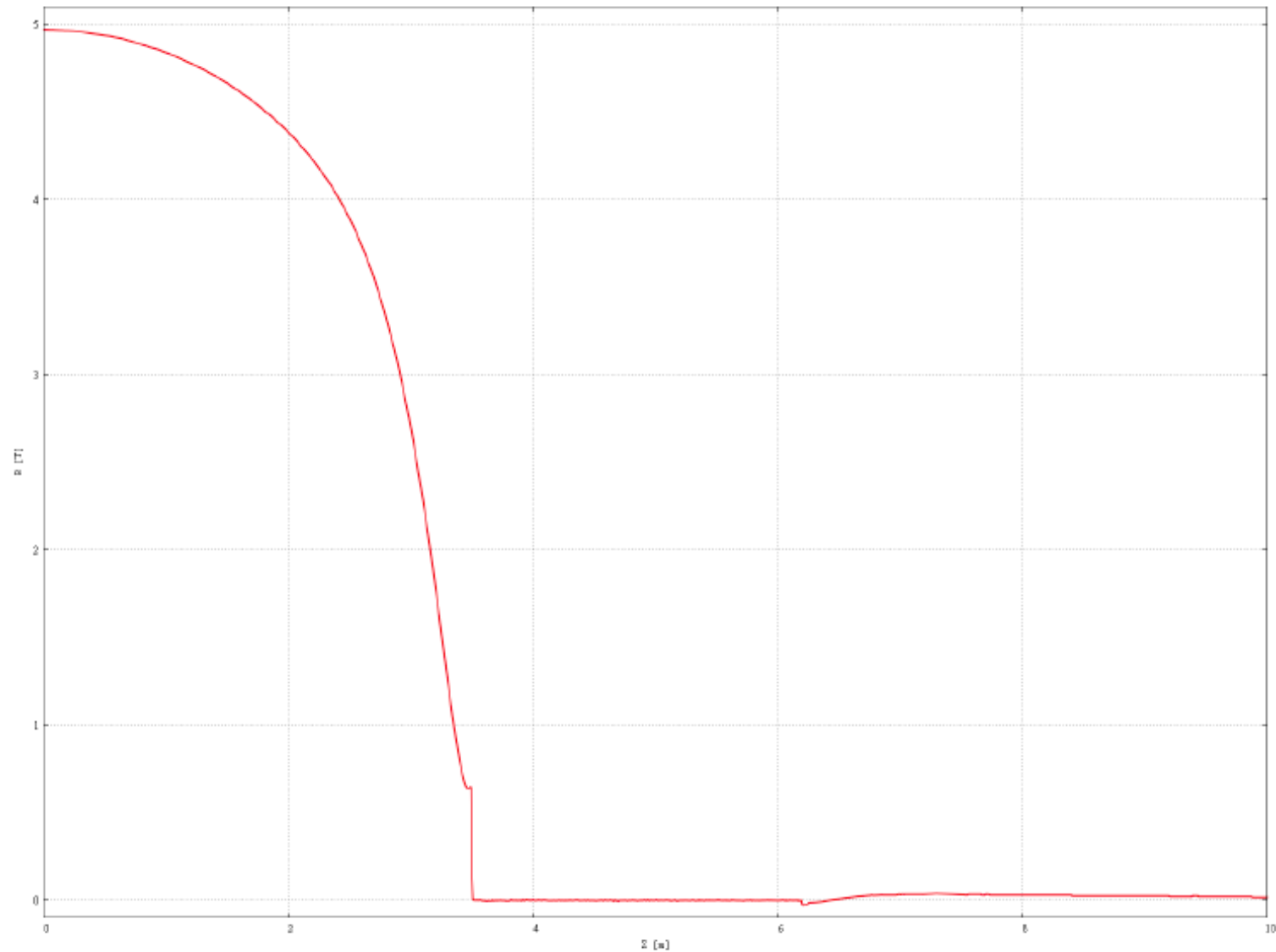

- Introduction
- QD0 prototype measurements
- QD0 pre-alignment
- QD0 stabilisation
- IP feedback
- Anti-solenoid compensation
- **Post-collision line** (back to MDI since 2012)
- Coming soon: study option with QD0 in tunnel



# Energy deposition in beamline components

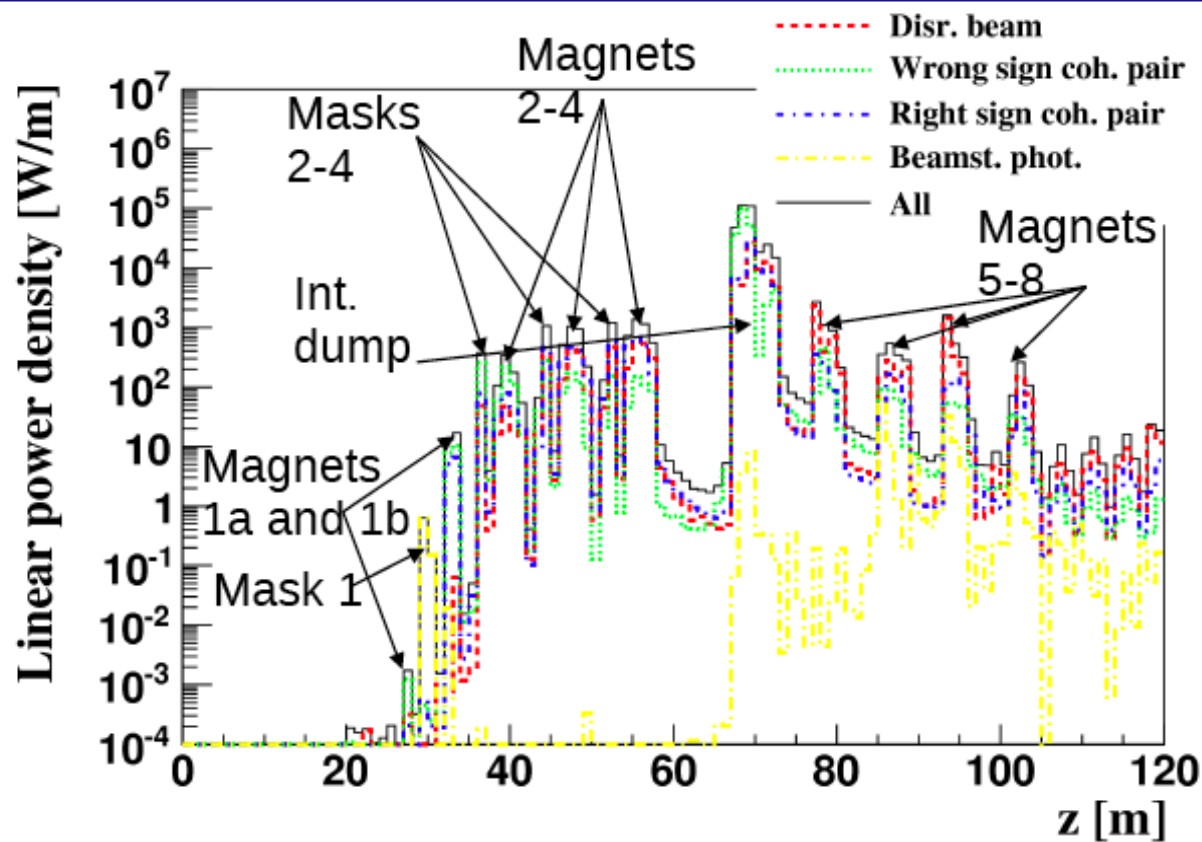

- IPAC 11, TUPC023
- As much energy lost in magnets as in masks
- For energy loss in *coils* of magnets 5-8, wrong sign coherents dominate.

# Magnet lifetime

- **[TUPC028 IPAC 2011]**, V1 is the original post-collision line, V2 is the changed version with iron masks and 2m longer intermediate dump.

Component	Rate of E. dep. In coils [W] – v1	Rate of E. dep. In coils [W] – v2	Volume of coils [cm <sup>3</sup> ]	Mass of coils [kg]	Lifetime [year] – v1	Lifetime [year] – v2
1a + 1b	0.37	4.57	327152	2931.28	2525.47	203.18
2	250.78	39.57	503936	4515.27	5.71	36.16
3	1338.49	216.88	579120	5188.92	1.23	7.58
4	1739.05	256.71	755904	6772.9	1.23	8.36
5	229.63	102.16	921600	8257.54	11.4	25.61
6	207.84	133.28	921600	8257.54	12.59	19.63
7	137.01	79.03	921600	8257.54	19.1	33.11
8	15.37	11.28	921600	8257.54	170.26	232.02

# New layout

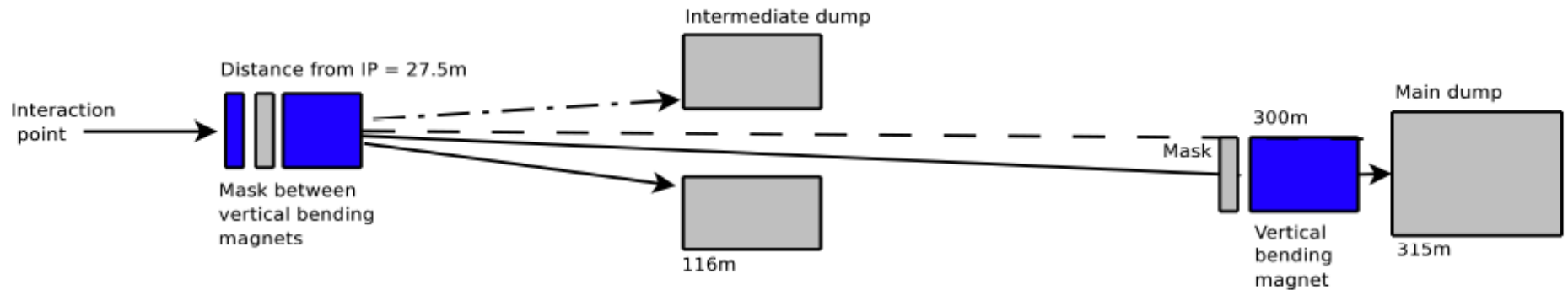

- Fewer magnets
- Downstream magnet further from intermediate dump
  - Less radiation damage
- Mask in front of last bending magnet coils

# Magnet lifetime study - new PCL

- New results
  - *Right:* energy dep. In magnet coil insulation material [ $\text{W}/\text{cm}^2$ ]
  - *Top right:* 1 litre voxels, magnet lifetime is 68000 +/- 7000
  - *Bottom right:* 125 cm<sup>3</sup> voxels lifetime 900 +/- 100 years

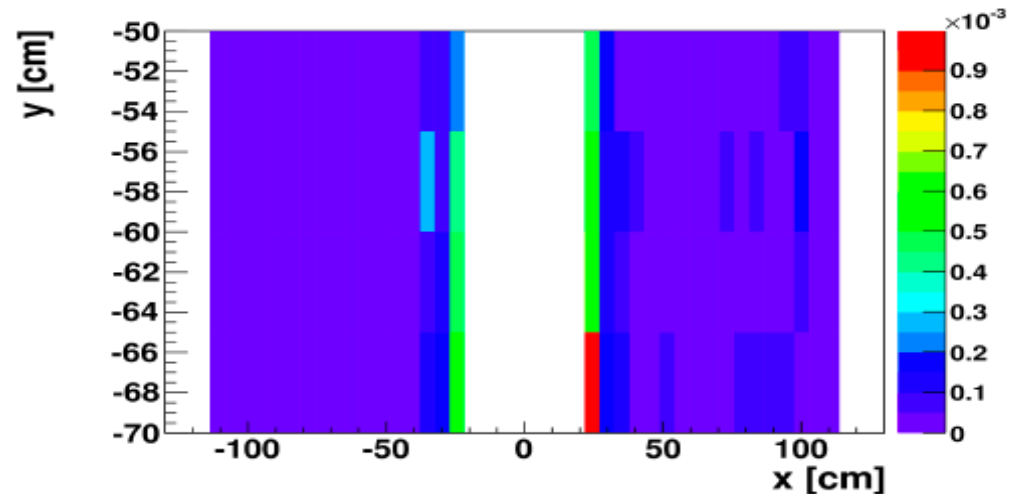
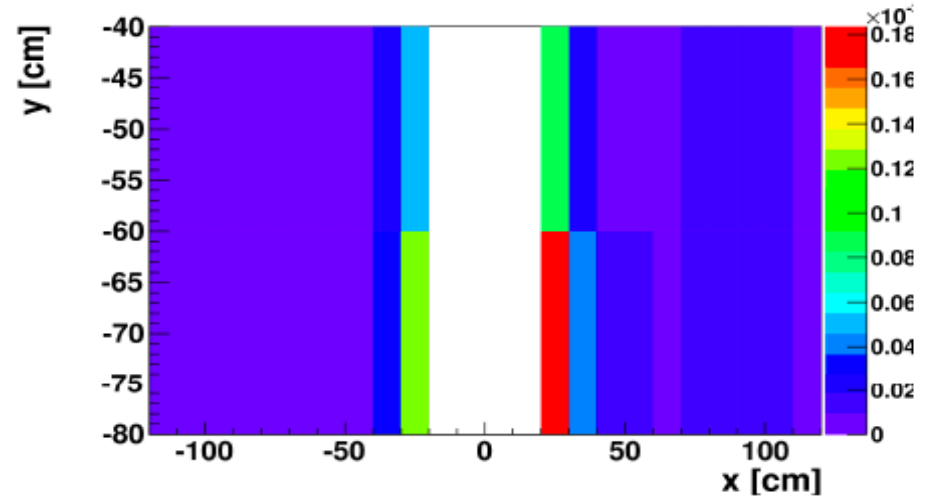

*See talk by L.Deacon  
on Thursday afternoon*



- Introduction
- QD0 prototype measurements
- QD0 pre-alignment
- QD0 stabilisation
- IP feedback
- Anti-solenoid compensation
- Post-collision line (back to MDI since 2012)
- Coming soon: study **option with QD0 in tunnel**

$L^* = 3.5 \text{ m}$

*Detector*

Solenoid  
d  
B-field

AntiSol

QD0

Integration

QD0

Radiation

Stabilisation

Lever arm

Space

Forces

AntiSol

Prealignment

Tunnel floor

z  
[m]

IP 2 4 6 8 10

$L^* = 6.5 \text{ m}$

*Detector*

AntiSol

QD0

AntiSol

QD0

Stabilisation

Prealignment

Tunnel floor

z  
[m]

IP 2 4 6 8 10

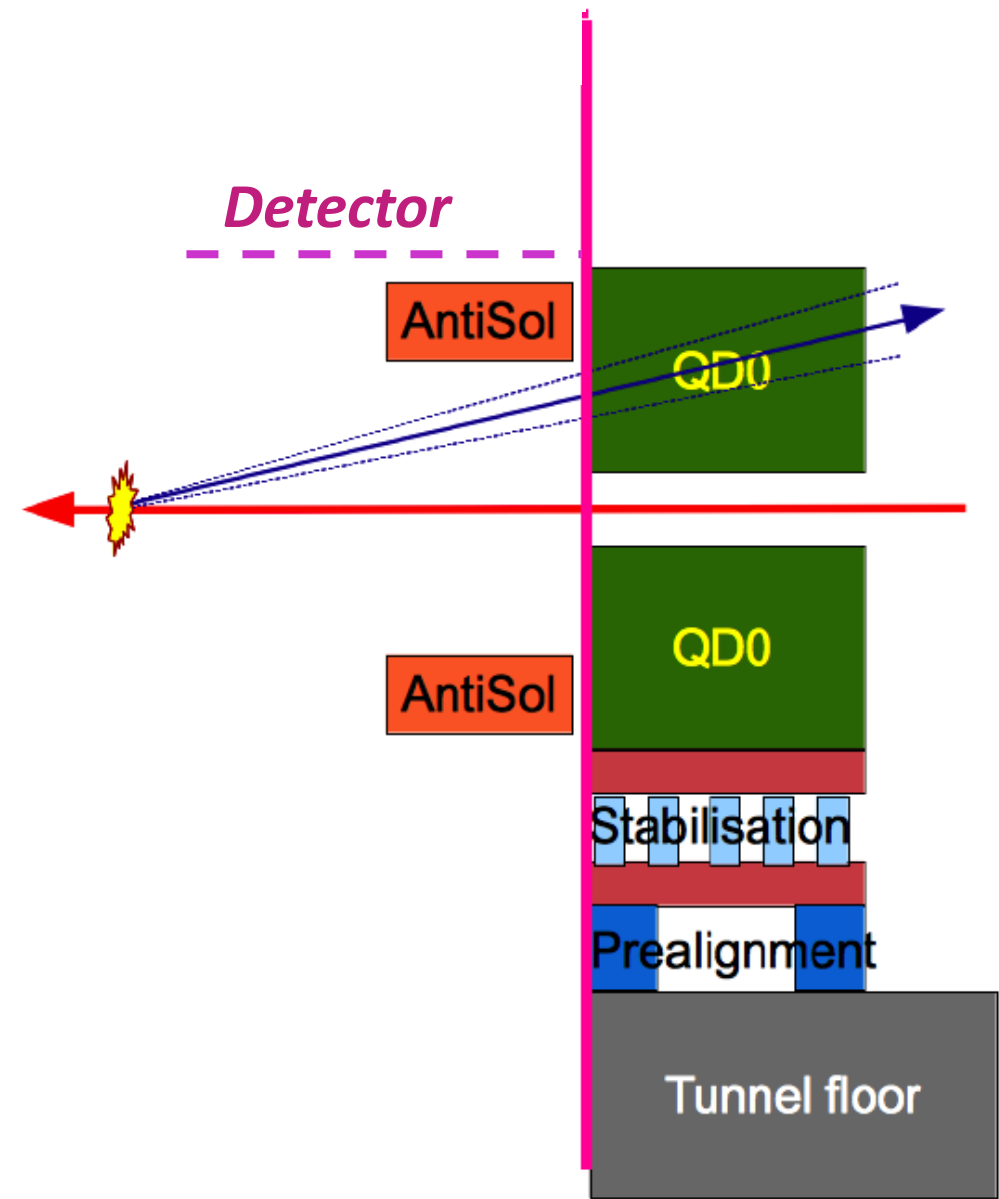
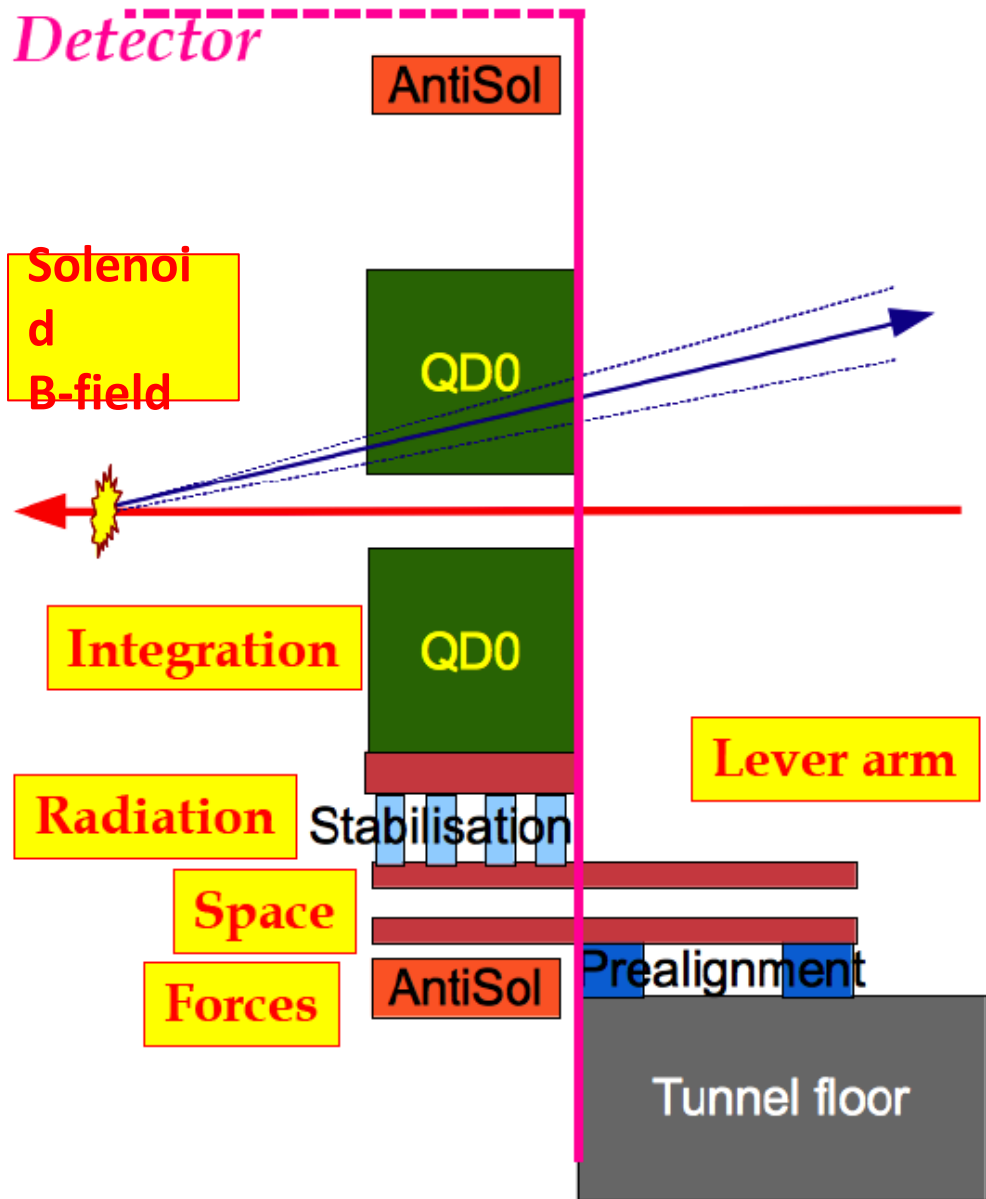

# So the questions are

- How much luminosity does one lose (on paper)?
- How much acceptance can one gain (on paper)?
- How serious is the luminosity loss with respect to the difficulties to keep it stable inside the detector environment, i.e. are there effective luminosity losses due to such issues for the short  $L^*$  ?
- What is the net balance between luminosity and acceptance in terms of the physics reach?

**This is now being addressed**

# MDI members and contributors

Julie Allibe, Alexander Alov, Robert Appleby, Armen Apyan, Kurt Artoos, Guillermo Zamudio Ascensio, Jerome Axensalva, Antonio Bartalesi, Marco Battaglia, Gerjan Bobbink, Enrico Bravin, Laurent Brunetti, Helmut Burkhardt, Phil Burrows, Francois Butin, Christophe Collette, Barbara Dalena, Fernando Duarte Ramos, Lawrence Deacon, Konrad Elsener, Arnaud Ferrari, Andrea Gaddi, Mark A. Gallilee, Martin Gastal, Lau Gatignon, Hubert Gerwig, Christian Glenn, Harry van der Graaf, Christian Grefe, Edda Gschwendtner, Michel Guinchard, Alain Hervé, Andréa Jérémie, Michel Jonker, YoungIm Kim, Andrea Latina, Thibaut Lefèvre, Yngve Levinsen, Lucie Linssen, Helène Mainaud Durand, Sophie Mallows, Dirk Mergelkuhl, Michele Modena, John Osborne, Thomas Otto, Colin Perry, Javier Resta Lopez, Giovanni Rumolo, André Philippe Sailer, Hermann Schmickler, Daniel Schulte, Jochem Snuverink, Markus Sylte, Rogelio Tomàs Garcia, Davide Tommasini, Raymond Veness, Joachim Voltaire, Alexey Vorozhtsov, Volker Ziemann, Franck Zimmermann