

High brightness beam generation with a photo-cathode 500kV DC gun

Hiroshima University/KEK
Masao KURIKI



Contents



- Introduction
- Photo-cathode 500kV DC gun
- HV test and beam test
- Summary



Introduction

ILC Design parameter

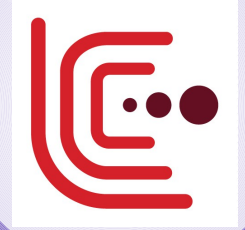
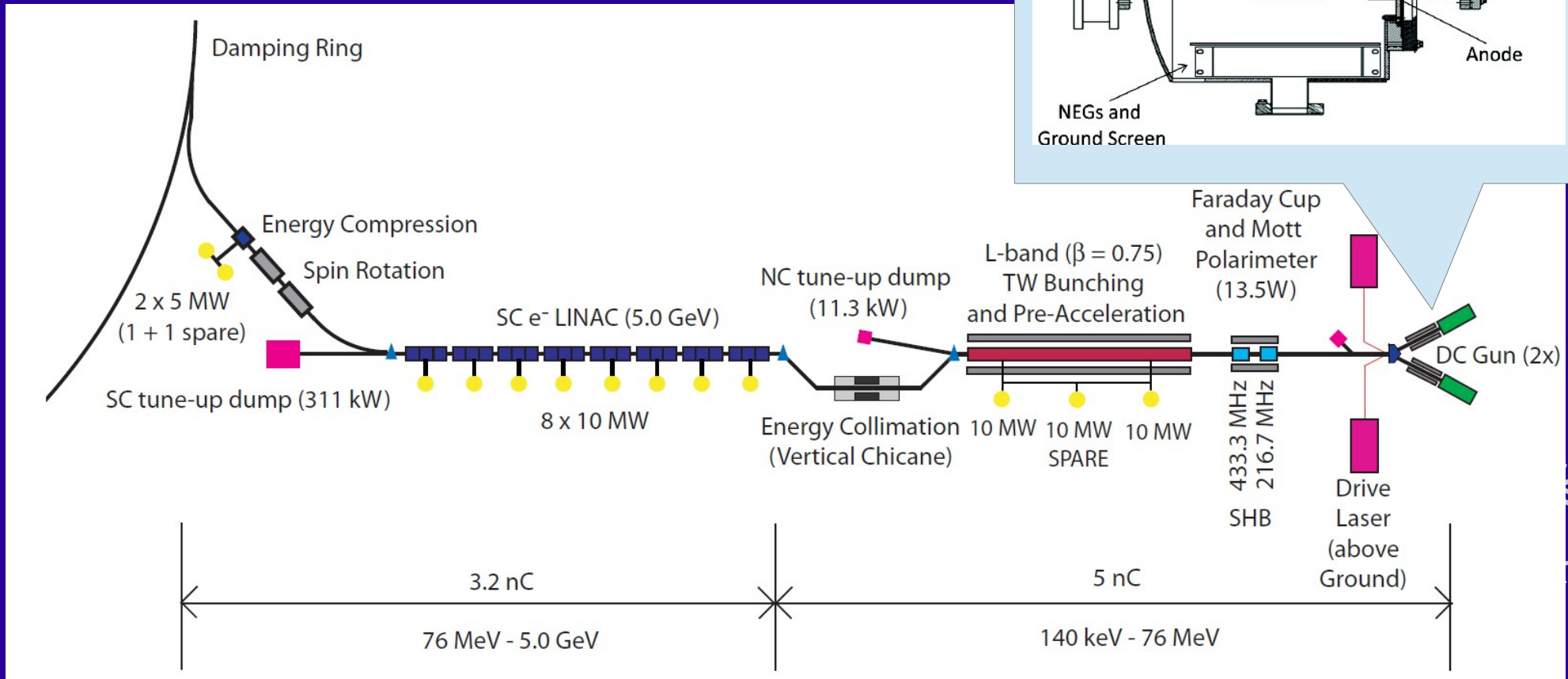
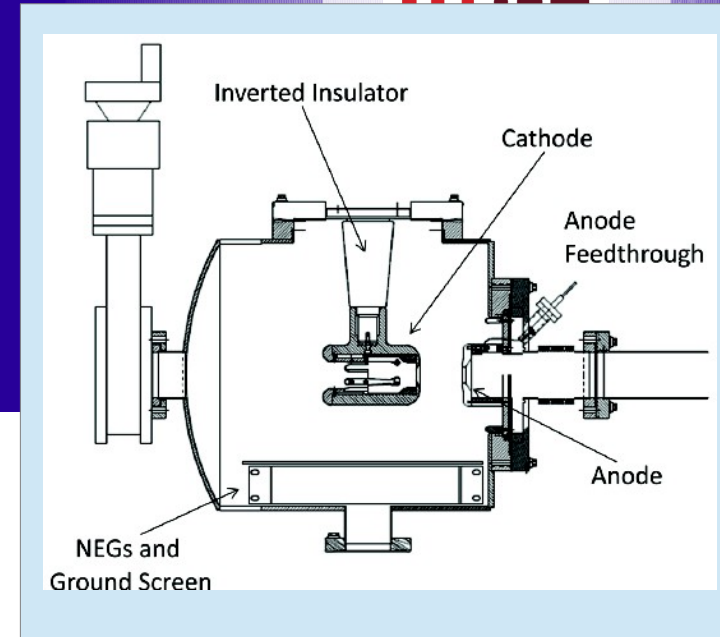

Table 4.1. Electron Source system parameters.

Parameter	Symbol	Value	Units
Electrons per bunch (at gun exit)	N_-	3×10^{10}	
Electrons per bunch (at DR injection)	N_-	2×10^{10}	
Number of bunches	n_b	1312	
Bunch repetition rate	f_b	1.8	MHz
Bunch-train repetition rate	f_{rep}	5	Hz
FW Bunch length at source	Δt	1	ns
Peak current in bunch at source	I_{avg}	3.2	A
Energy stability	σ_E/E	<5	% rms
Polarisation	P_e	80 (min)	%
Photocathode Quantum Efficiency	QE	0.5	%
Drive laser wavelength	λ	790 ± 20 (tunable)	nm
Single-bunch laser energy	u_b	5	μJ

ILC electron source (1)

- NEA GaAs/GaAsP superlattice cathode.
- 200kV inverted type DC gun.
- >80% pol. , 3.2nC/bunch at IP.



ILC electron source (2)



- NEA GaAs/GaAsP for polarization is not compatible to RF Gun; DC photo-cathode gun is the only solution for LC.
- Current density from 200kV gun is limited by space charge resulting ~ 1 ns bunch length.
 - 1ns \rightarrow 200ps : two SHBs (316.7 and 433.3MHz).
 - 200ps \rightarrow 20ps : TW 1.3GHz buncher ($\beta=0.75$).
 - Solenoid field for focusing.
- It is desirable to increase HV for shorter initial bunch length.
 - Simplfy the bunching section.
 - Potentially less beam loss and less margin.
- Improving 200kV \rightarrow 500kV, the bunch length becomes 4 times shorter.



500kV DC gun

HV DC gun program in Japan



- Photo-cathode HV DC gun R&D program has been carried out by a collaboration among JAEA, KEK, Nagoya U. and Hiroshima U. since 2007.
- This is a common effort for multiple projects: ERL light source, Laser Compton Scattering photon source(Quantum Beam project), and Linear Colliders.
- 500kV and high beam current operation has been confirmed in a test beam line.
- The gun is now under commissioning as the injector of Compact ERL at KEK which is a demo-machine for GeV class ERL light source.

Impact of HV on emittance

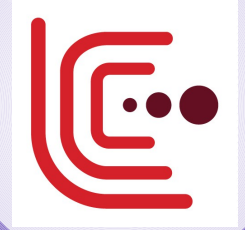

- Beam emittance is grown by non-linear space charge.
- High field of the gun makes the beam emittance better by preventing the emittance growth.

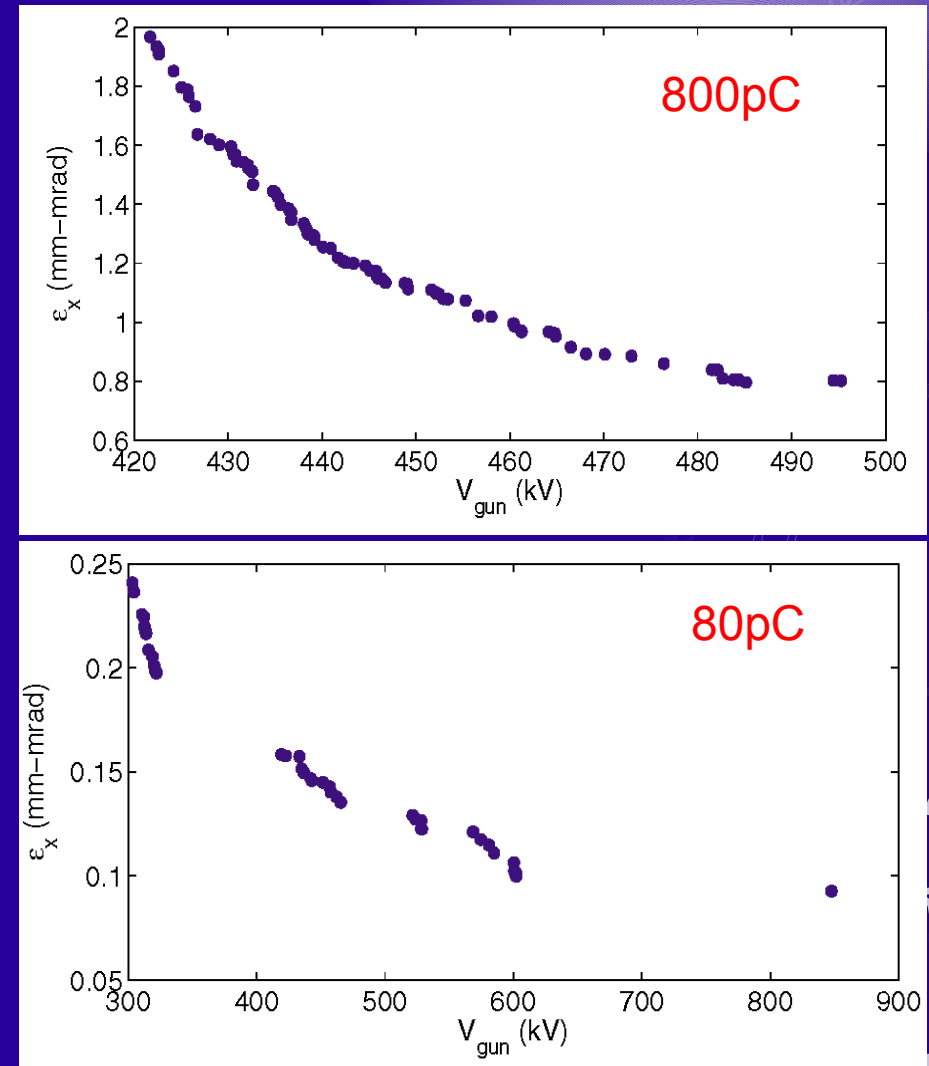

I. V. Bazarov and C. K. Sinclair,
PRSTAB 8, 034202 (2005)

ERL Project in Japan

- The next generation SR light source based on 3 GeV ERL (PERL) has been proposed.
- PERL is extendable to X-ray FEL oscillator.
- For technical demonstration, cERL (compact ERL) is now under commissioning.
- cERL: Laser Compton X/ γ -ray sources.



Parameters	Value
Energy	35/245 MeV
Current	10mA
Emittance (norm.)	0.1-1.0 mm.mrad



Quantum Beam Project



- High brightness X-ray source with LCS (Laser Compton Scattering) based on Super-conducting accelerator.
- Experiment was carried out at STF (Superconducting Test Facility, KEK) with a L-band NC RF gun.
- A conceptual design with DC PC gun has 400 times more brightness because of the high duty.

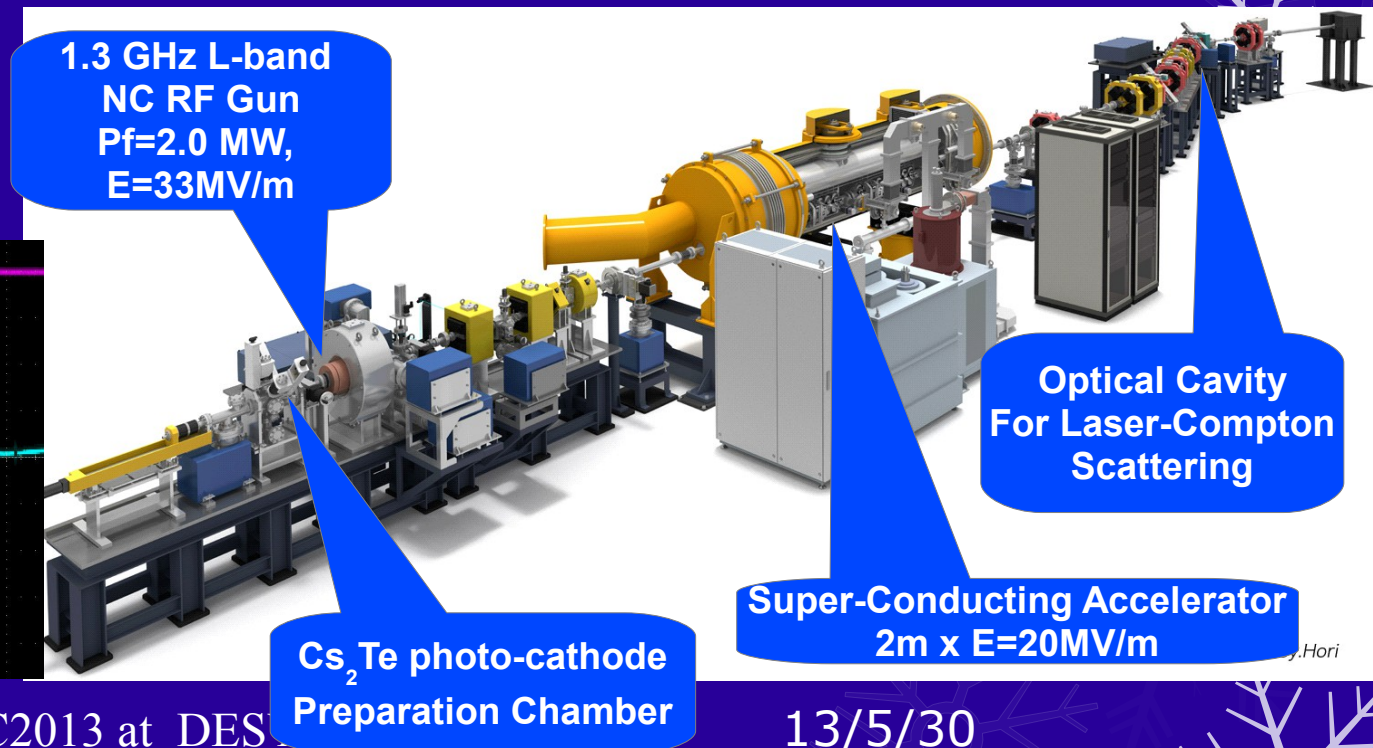
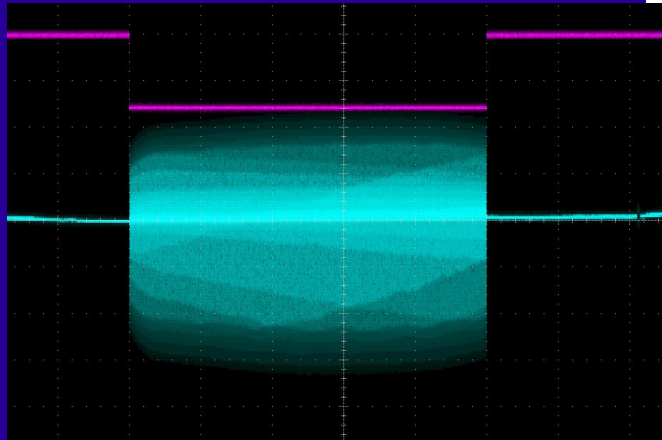

500kV DC gun



- 500kV DC biased gun with ceramic insulator.
- High voltage and high field are essential for high brightness and low emittance beam generation.
- Guard rings on the ceramic insulator prevent HV breakdown and ceramic punch through.
- The guard rings are also effective to prevent concentration of the bias voltage in a small region.

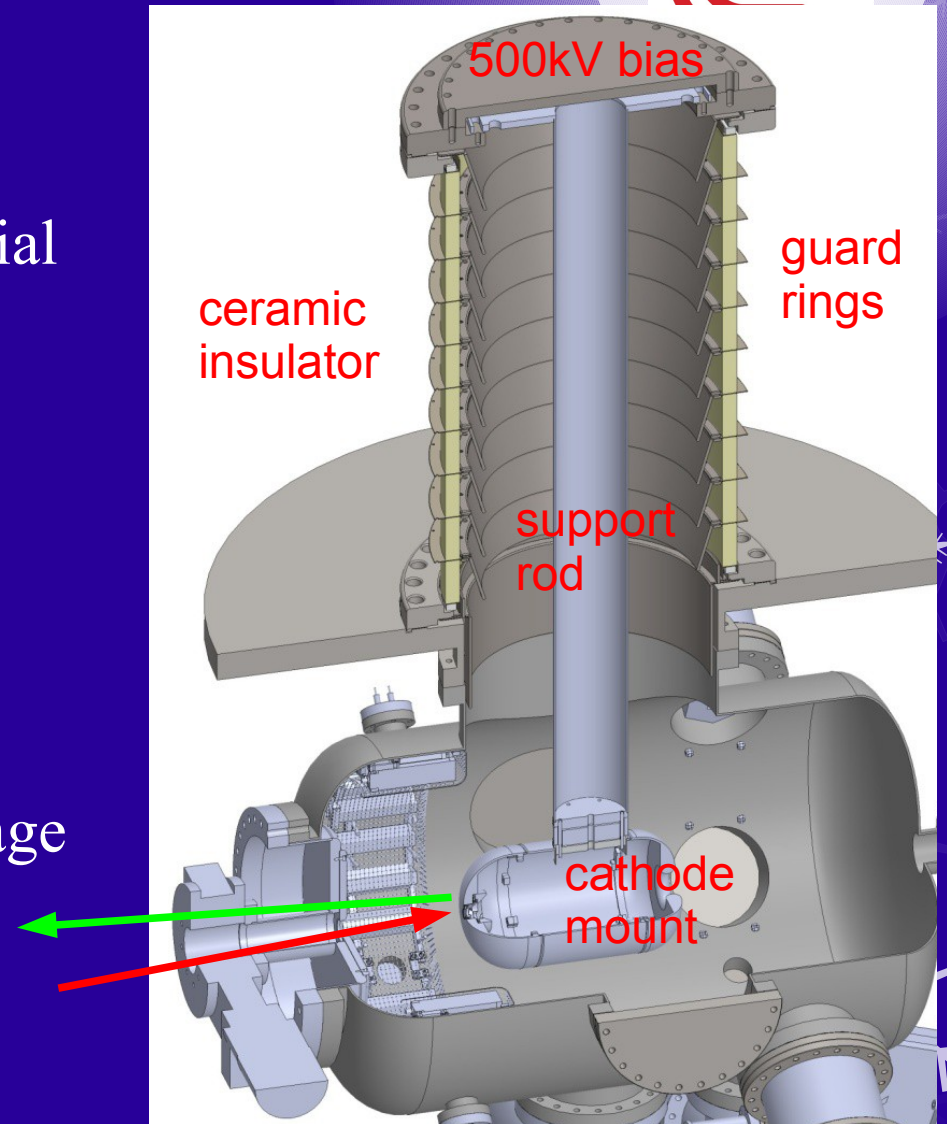

Segmented Structure with guard rings (1)



Segmented

- HV of DC gun has been limited by ceramic insulator destruction.
- The reason is considered to be field emission from the support rod and field concentration by discharge.
- To prevent these phenomena, we employed segmented structure with guard rings.

One insulator

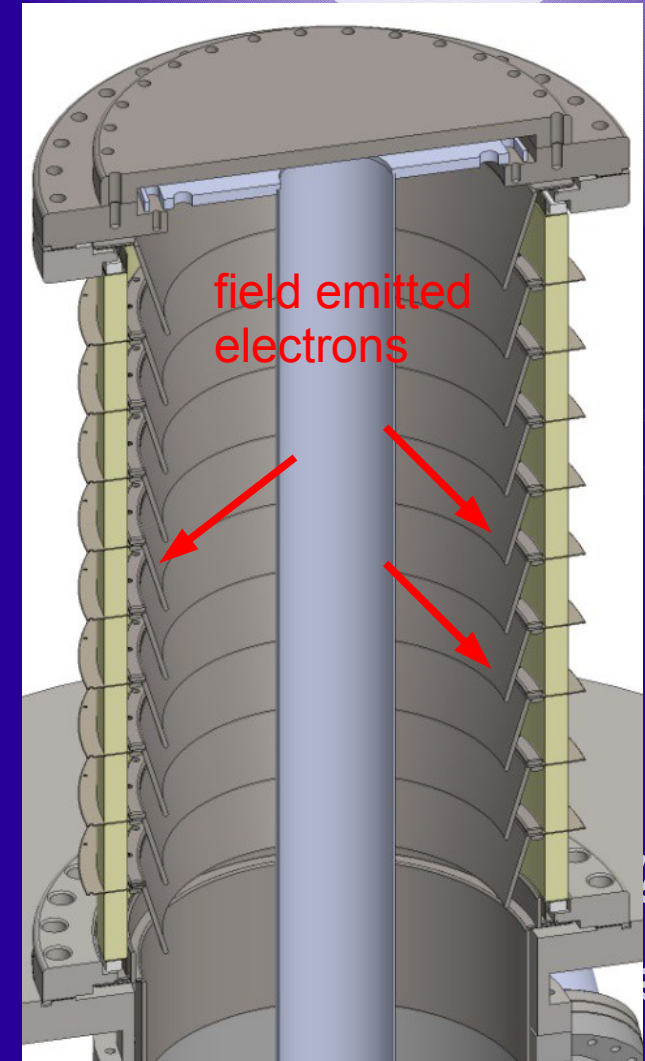
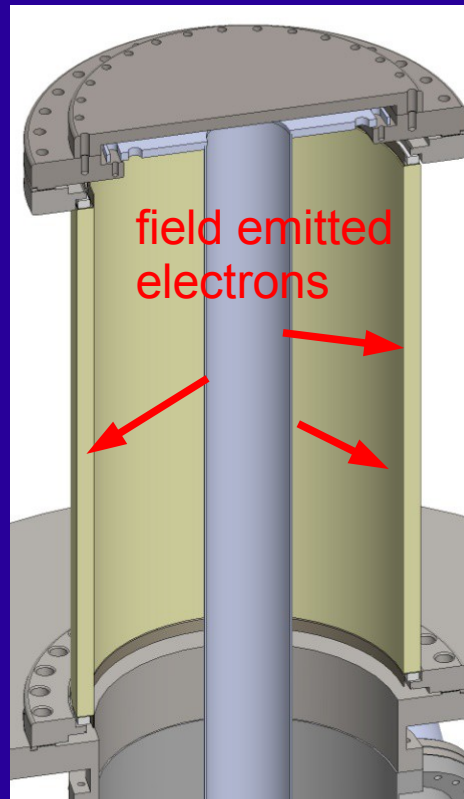

Segmented Structure with guard rings (2)



- Guard rings shade the ceramic from electrons emitted from the support rod by field emission.
- The bias voltage is distributed equally among each segments.
- Charge up and voltage concentration resulting ceramic destruction is therefore strongly prevented.

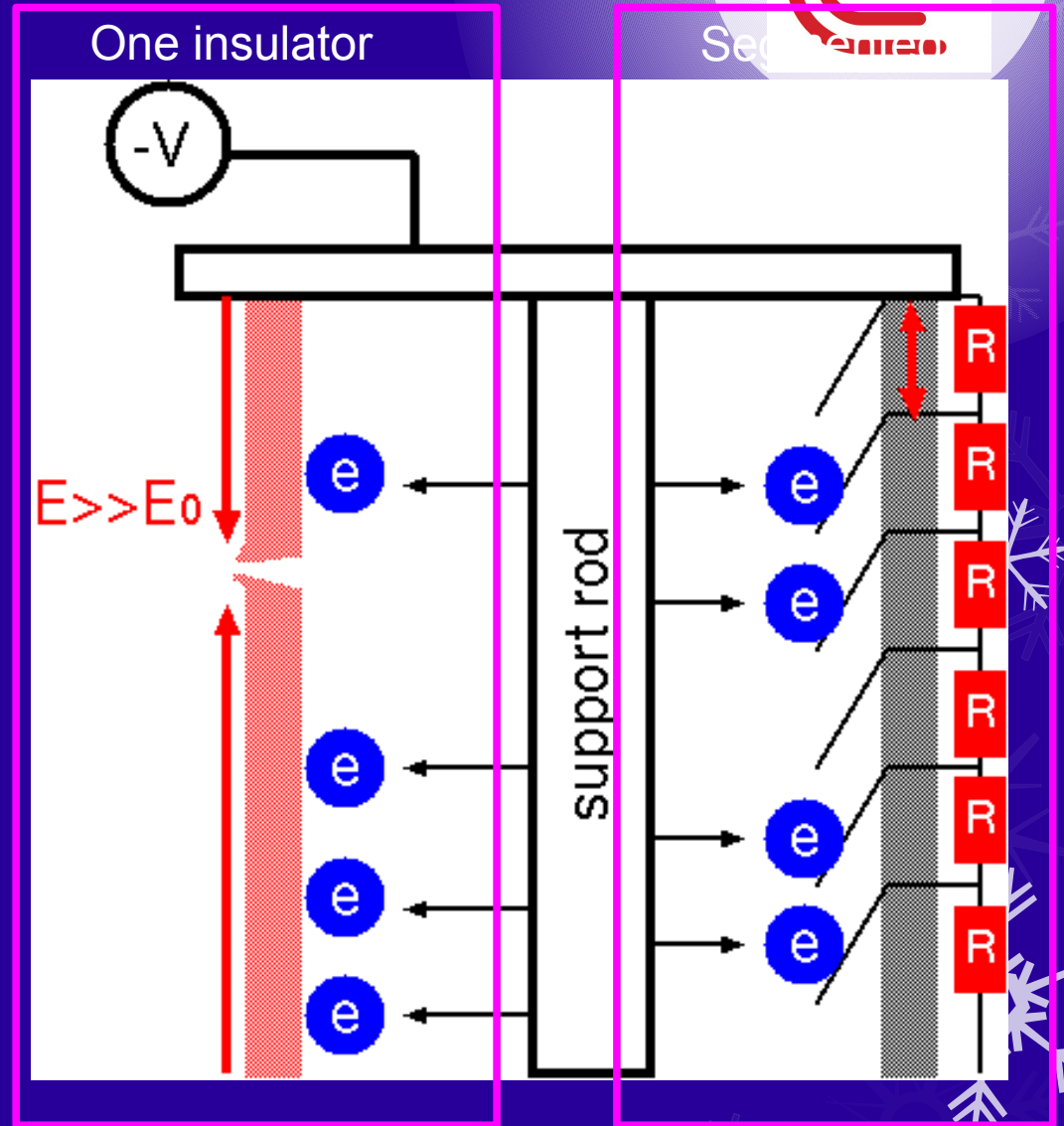



HV and Beam test

The 500kV DC gun system

- A 500kV DC photo-cathode gun with a cathode preparation system.
- High pumping ability by IP and NEG for extremely low vacuum pressure, $<1e-9$ Pa.
- Surface field <10 MV/m for less field emission.

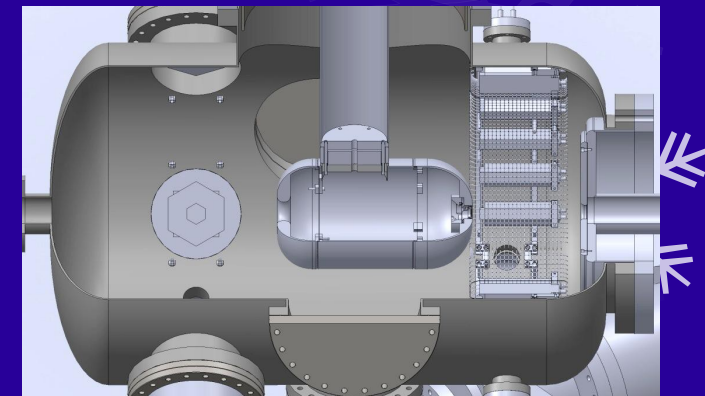
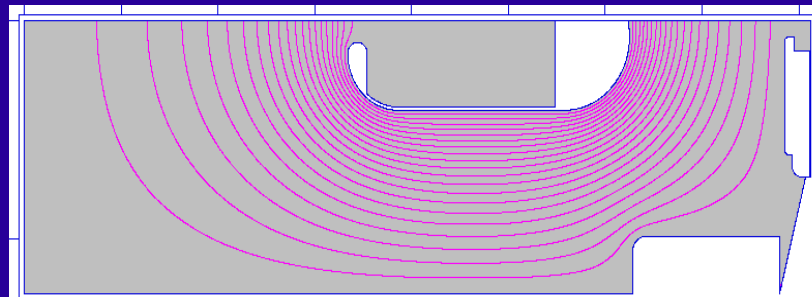
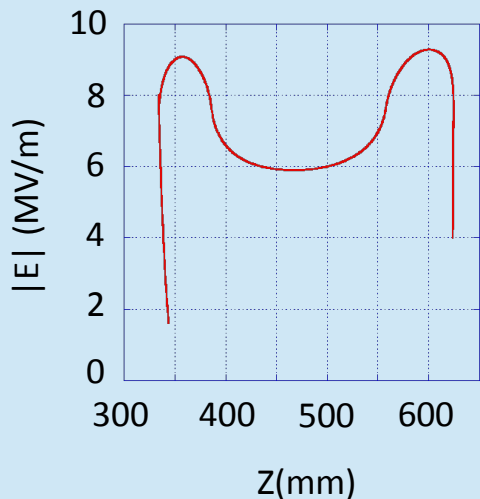
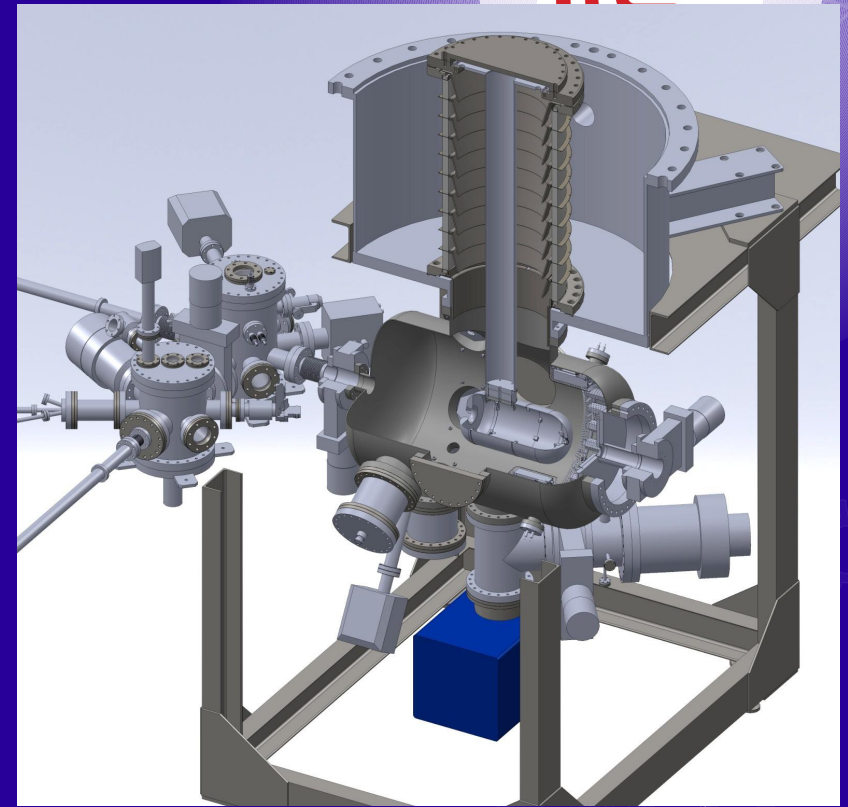

JAEA DC gun beam line



- HV and beam test was carried out at JAEADC gun beam line.
- Laser: 5W 532nm.
- $\sigma_x=0.1\text{mm}$.
- Water cooled beam dump which is capable to measure the beam current.
- Differential pumping to prevent contamination to the cathode.

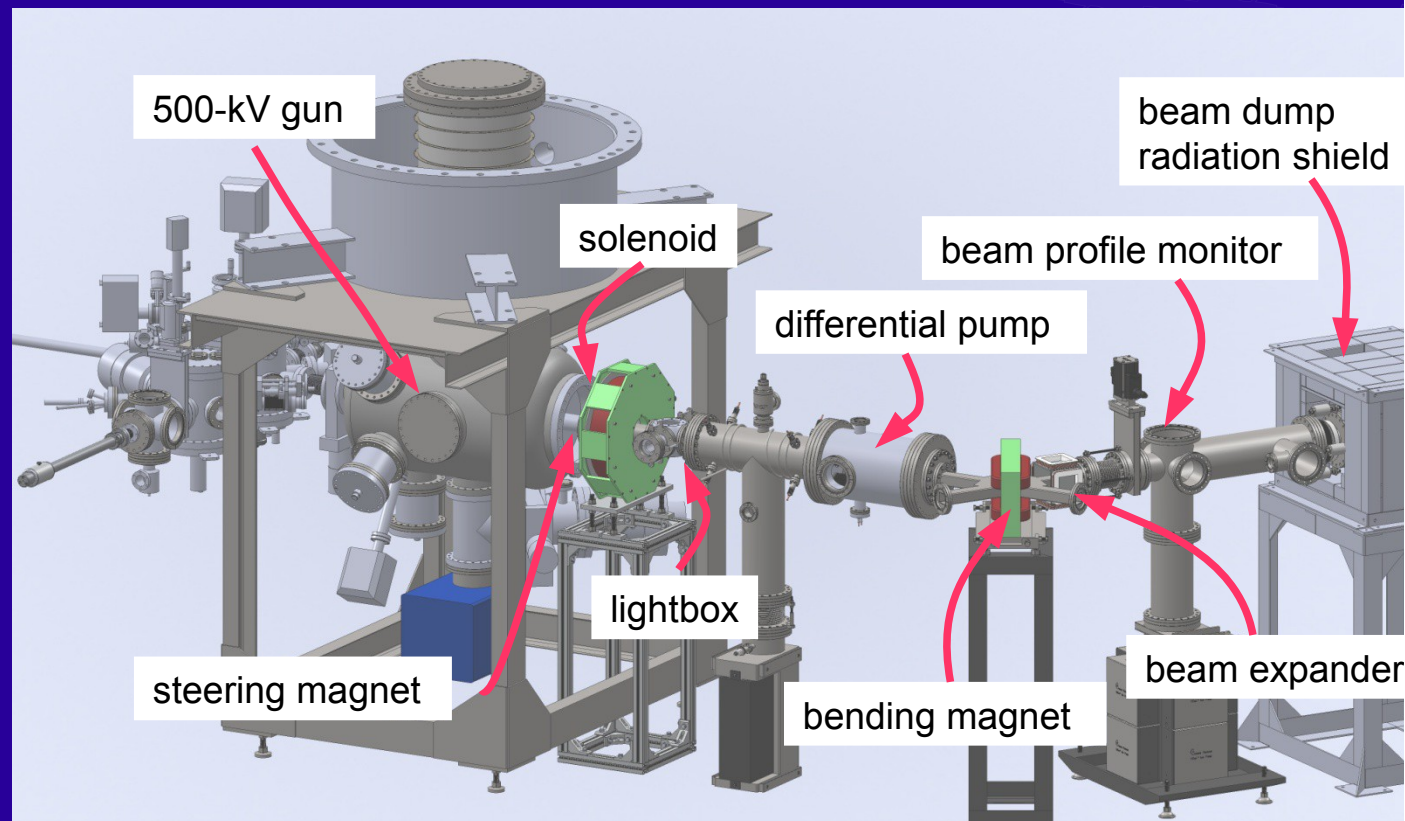

500keV Beam Operation



- After HV conditioning up to 550kV, 500kV was quickly achieved.
- $> 2.0\text{mA}$ current was achieved with 1.5 W laser and 0.28% QE.
- Vacuum pressure at gun was maintained at UHV during the operation.

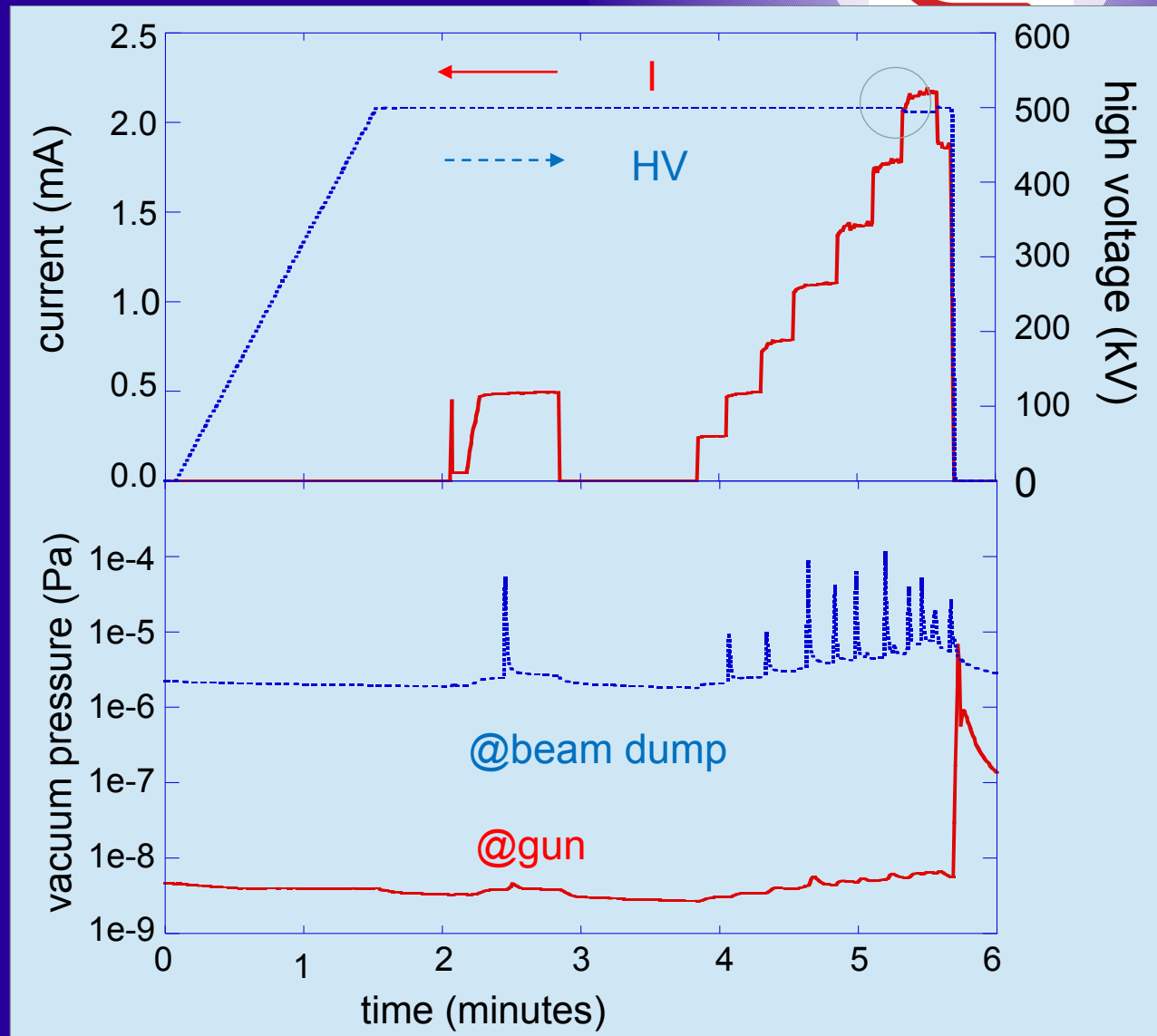

10mA Beam operation



- 10 mA beam operation has been demonstrated.
- The test was carried out at lower voltage (180keV) due to field emission from dust which was fixed by wiping.
- 10mA was achieved, but a significant vacuum pressure escalation was observed.

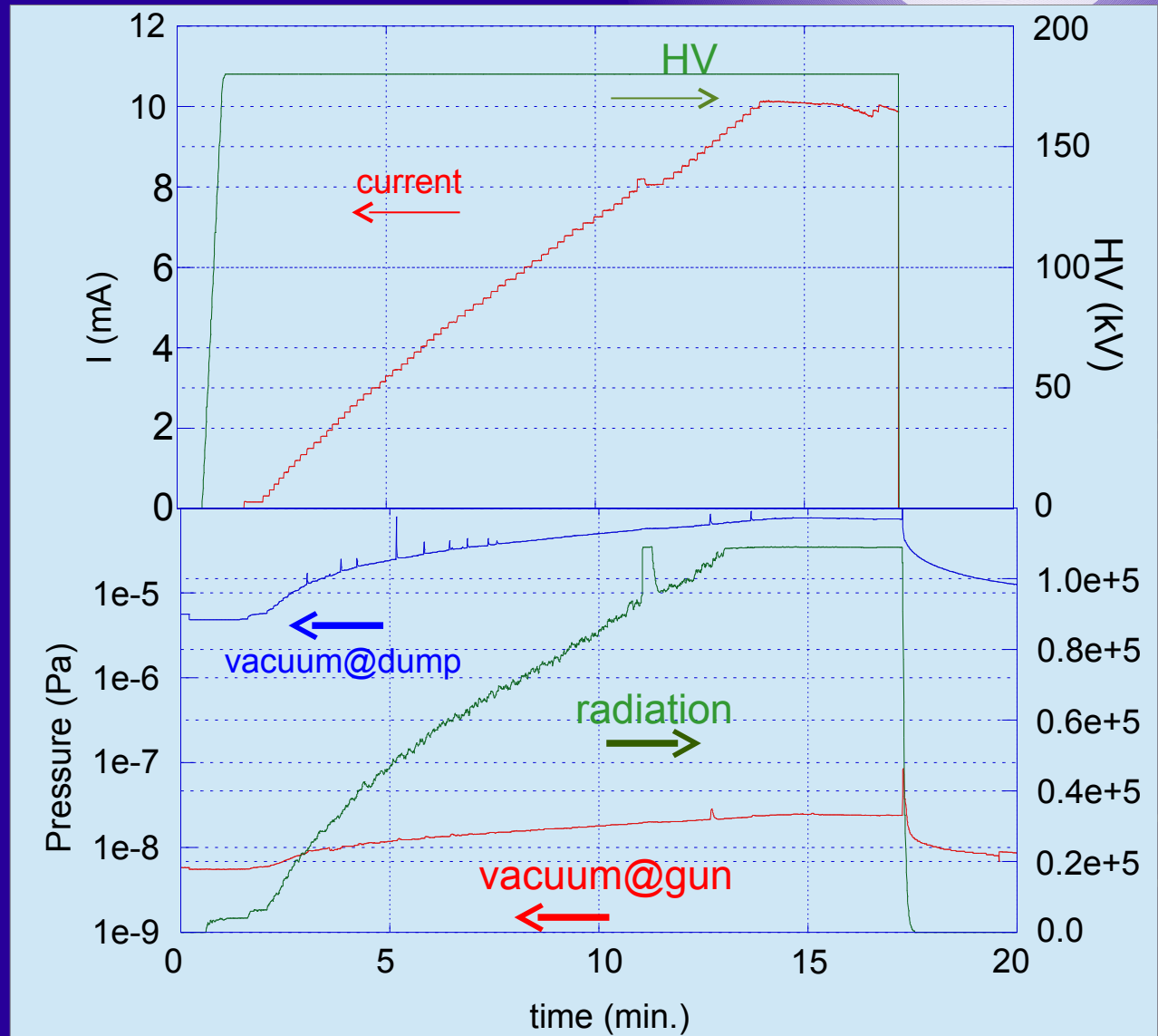

Operational Lifetime



- Operational lifetime was examined by continuous beam operation.
- Beam current decay was observed showing QE degradation.
- Charge lifetime was extracted to be 48C.
- It is enough for LCs, but not sufficient for ERL light source.

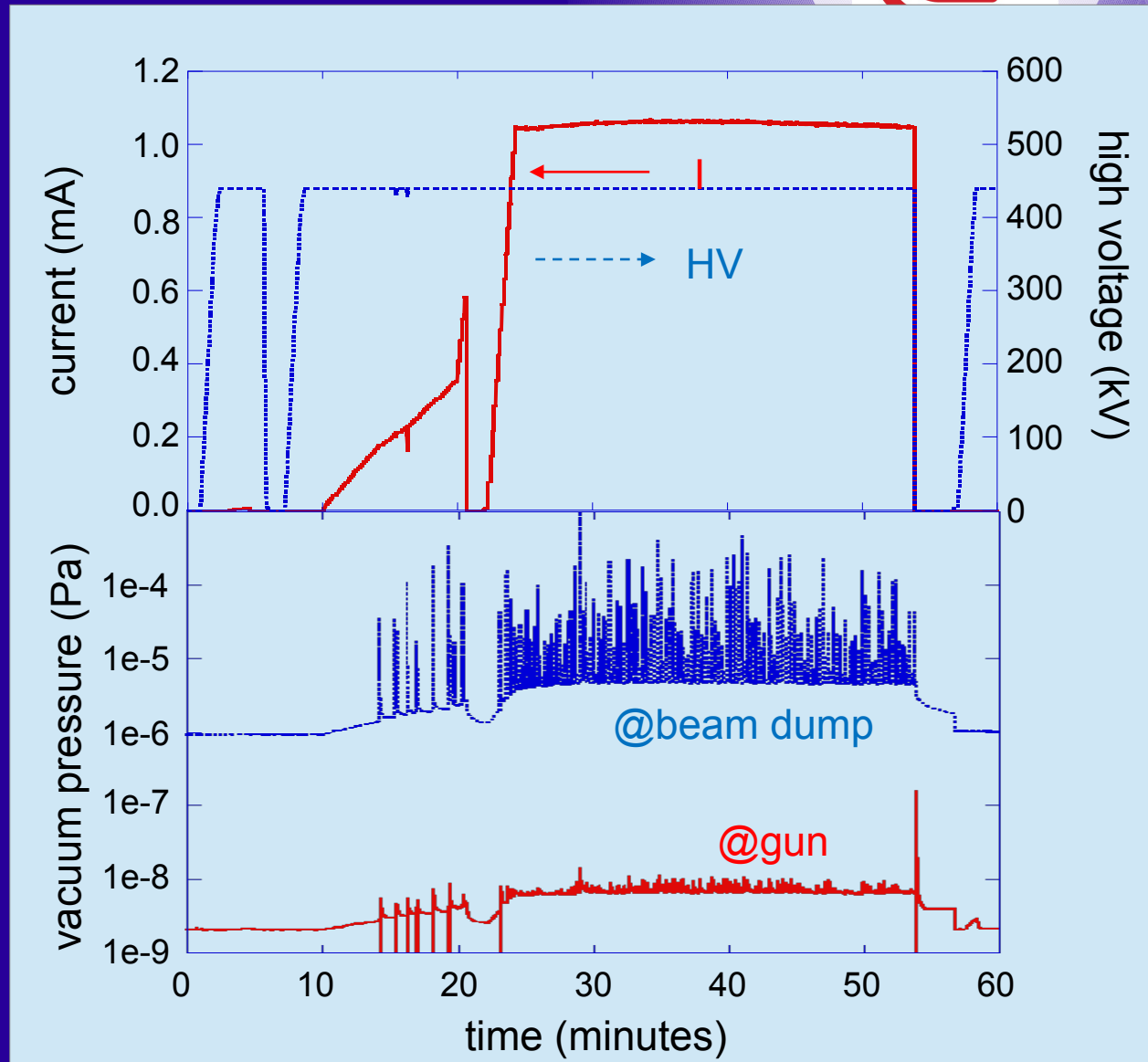

Move to cERL

- The developed gun has been moved to cERL at KEK.
- Now, the gun is under commissioning.
- The electron beam from the cERL gun has been confirmed.
- Performance of the cERL gun will be examined in the commissioning.

Stay tuned!



Summary



- 500kV DC photo-cathode gun is developed for multiple accelerator projects which require highly polarized and/or high brightness electron beam.
- Stable operation at 500kV has been confirmed.
- 10mA beam generation has been demonstrated.
- The gun is now under commissioning for cERL at KEK.
- The technology is applicable for ILC.
 - The bunch length from the gun can be shorten.
 - The bunching section can be simplified.
 - The energy spread could be less.

500kV DC gun R&D group



N. Nishimori^{a)}, R. Nagai^{a)}, S. Matsuba^{a)}, R. Hajima^{a)}, M. Yamamoto^{b)}, Y. Honda^{b)}, T. Miyajima^{b)}, H. Iijima^{c)}, M. Kuriki^{c)}, M. Kuwahara^{d)}

a) JAEA, b) KEK, c) Hiroshima U., d) Nagoya U.