



Collective effects in Damping rings

Yannis PAPAPHILIPPOU
Accelerator and Beam Physics group
Beams Department
CERN

Eighth International Accelerator School for Linear Colliders
4-15 December 2013, Antalya

- So far, the beam dynamics effects, ignored interaction of particles with each other and the vacuum chamber environment, i.e. results are independent on bunch charge
- There are many effects of collective nature that depend directly on the bunch intensity. Important ones for the damping rings include:
 - Space Charge
 - Intrabeam scattering
 - Microwave instability
 - Coupled-bunch instabilities
 - Fast-ion instability
 - Electron-cloud
- Observed phenomena associated with each effect can vary widely, depending on the exact conditions in the machine
- Not all effects modeled with sufficient accuracy or completeness, to allow completely confident predictions...

- Each particle in the bunch sees electric and magnetic fields from all the other particles in the bunch.

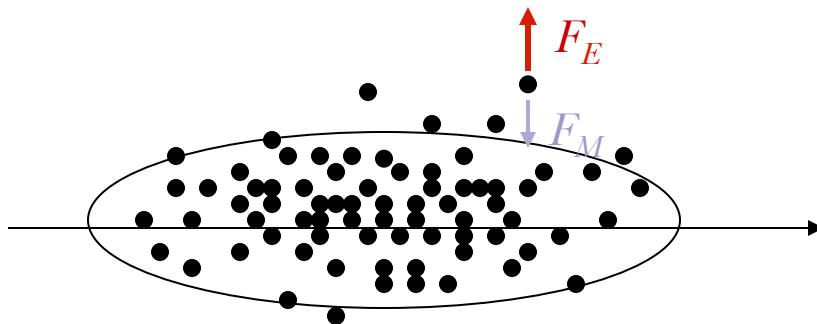

- For bunches moving close to the speed of light, magnetic force almost cancels the electric force.
- Viewed in the rest frame of the bunch, there is no magnetic force (neglecting the relative motion of the particles within the bunch)
- But the expansion driven by the Coulomb forces is slowed by time dilation when viewed in the lab frame

- An expression for the vertical space-charge force (normalized to the reference momentum), for Gaussian bunches expanded to first order in y is:

$$F_y \approx 2 \frac{r_e}{\gamma^3} \frac{\lambda_z}{\sigma_y (\sigma_x + \sigma_y)} y$$

- r_e is the classical radius of the electron
 - γ is the beam energy
 - λ_z is the longitudinal density of particles in the bunch
 - σ_x, σ_y are the rms bunch sizes.
- The vertical force (integrated around the lattice) results in a vertical tune shift:

$$\Delta \nu_y \approx -\frac{1}{4\pi} \oint \beta_y \frac{\partial F_y}{\partial y} ds$$

- Since the density depends on the longitudinal position in the bunch, and the force F_y is really nonlinear, every particle experiences a different tune shift therefore, the tune *shift* is really a tune *spread*, or an “incoherent” tune shift

- The space charge incoherent tune shift can be written:

$$\Delta \nu_y \approx - \frac{r_e}{2\pi\gamma^3} \oint \frac{\beta_y \lambda_z}{\sigma_y (\sigma_x + \sigma_y)} ds$$

- Note the factor $1/\gamma^3$; for high-energy electron storage rings, this generally suppresses the space charge forces so that the effects are negligible. However, the tune shift becomes appreciable (~ 0.1 or larger) when:
 - the longitudinal charge density is high
 - the vertical beam size is very small
 - the circumference of the ring is large
- The damping rings will operate at reasonably high bunch charges and very small vertical emittances
- Space-charge effects need to be considered...

- Especially for longer rings and shorter bunches vertical tune-shifts become significantly large
- This can lead to emittance growth and dedicated codes are needed to evaluate the effect

Lattice	Beam energy	Circumference	Bunch length	$\Delta\nu_x$	$\Delta\nu_y$
PPA	5 GeV	2.8 km	6 mm	-0.001	-0.021
OCS2	5 GeV	6.1 km	6 mm	-0.002	-0.083
BRU	3.74 GeV	6.3 km	9 mm	-0.009	-0.119
MCH	5 GeV	16 km	9 mm	-0.009	-0.176
TESLA	5 GeV	17 km	6 mm	-0.019	-0.313

- Tracking simulations including the nonlinear form of the space charge forces are necessary
- Emittance growth is observed in both planes but mostly in the vertical

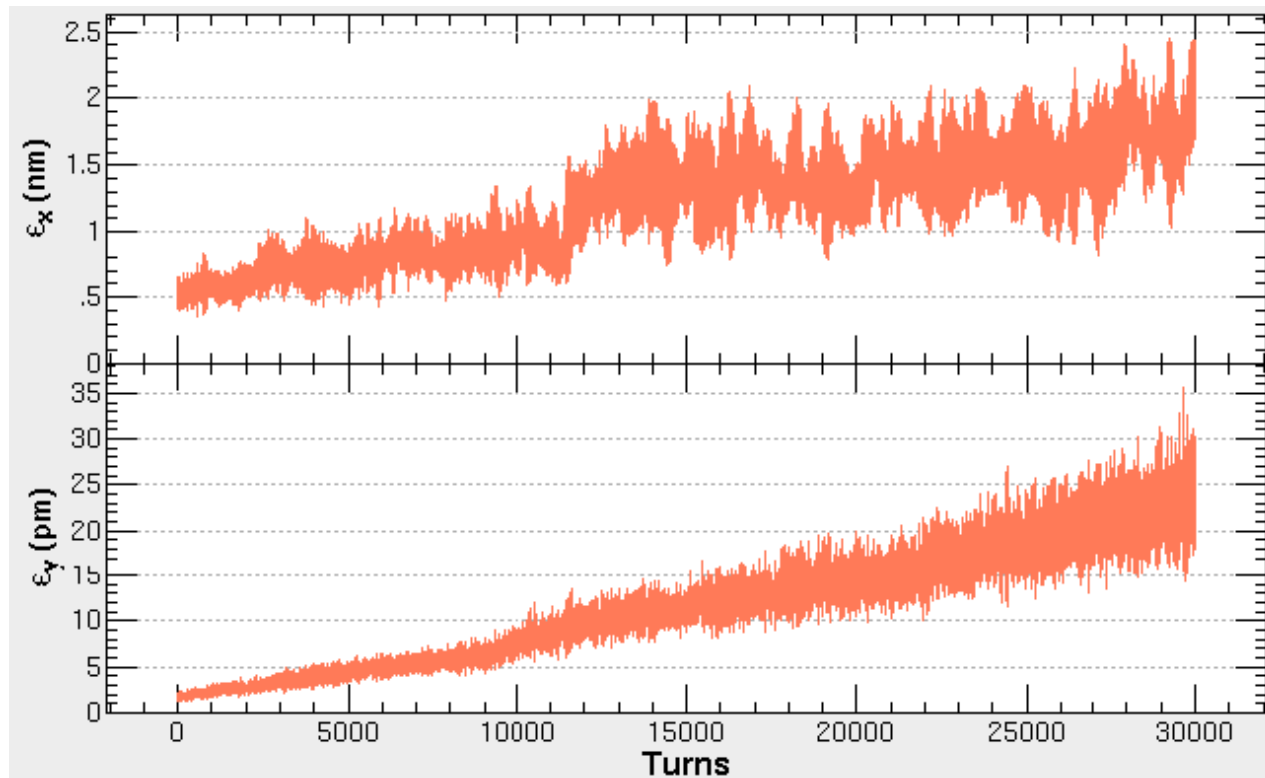

Emittance growth from space charge calculated by tracking in SAD (K. Oide)

- The emittance growth observed depends on the tunes of the lattice.

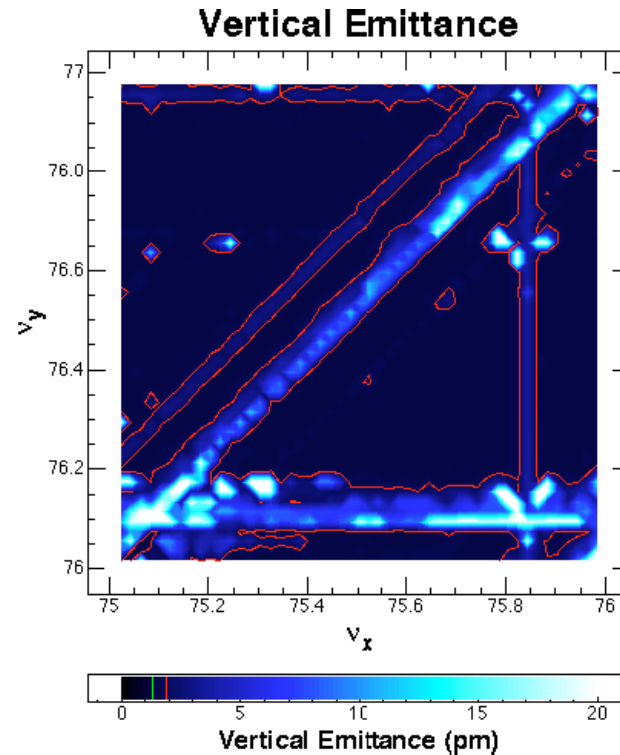
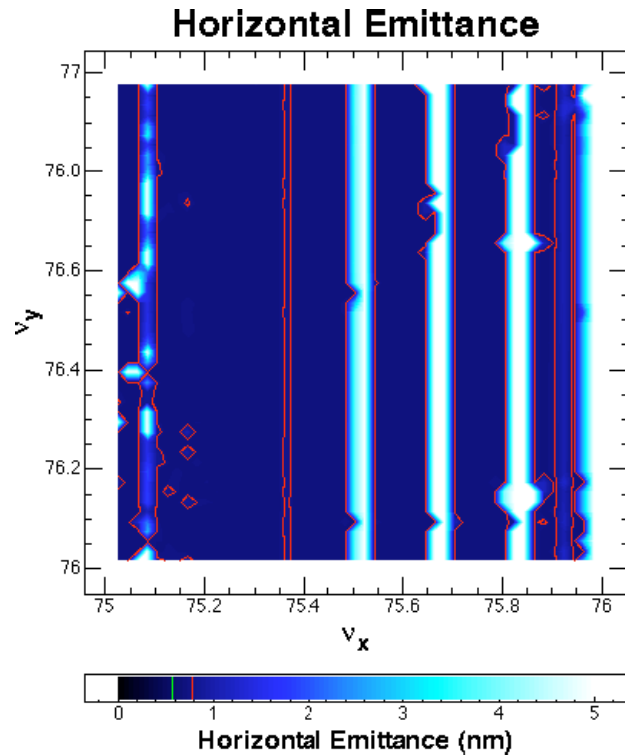

Tune scan of emittance growth from space charge
in a 17 km lattice calculated by tracking in SAD
(K. Oide)



- Space charge forces can be reduced by increasing the vertical beam size.
- In uncoupled lattice, this can be done (for a given emittance) by increasing the beta function
- An alternative is to use a “coupling transformation” that makes the horizontal emittance contribute to the vertical as well as the horizontal beam size. Even if the vertical emittance is orders of magnitude smaller than the horizontal, the beam can then be made to have a circular cross-section, without increasing the beta functions.
- In the old TESLA dogbone DRs, an appropriate transformation was used at the entrance to the long straight, and a corresponding transformation at the exit of the long straight, to remove the coupling and make the beam flat again
- Since there is no radiation emitted from the beam in the straight, the emittances are preserved!

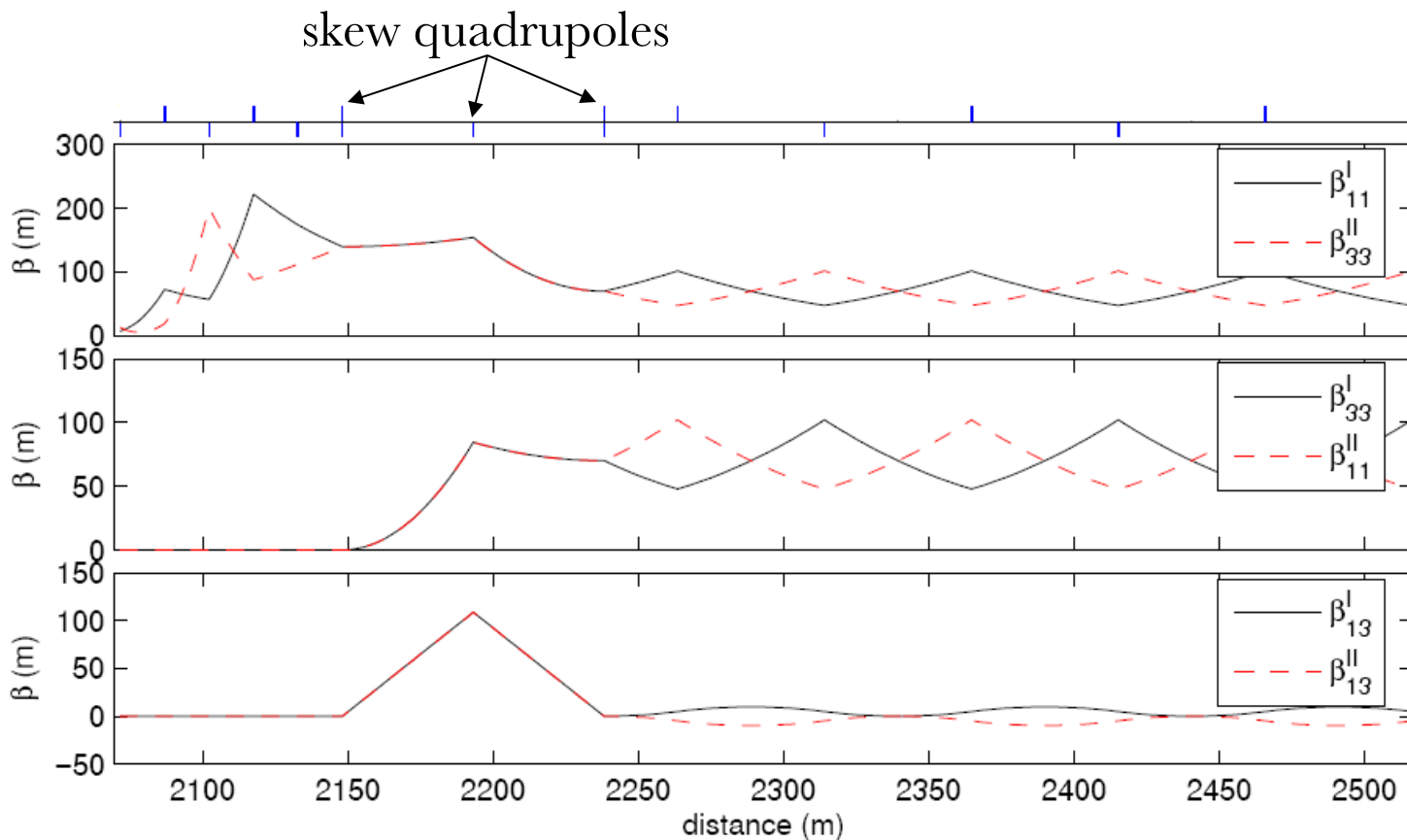

$$\langle x^2 \rangle = \beta_{11}^I \varepsilon_I + \beta_{11}^{II} \varepsilon_{II}$$

$$\langle xy \rangle = \beta_{13}^I \varepsilon_I + \beta_{13}^{II} \varepsilon_{II}$$

$$\langle y^2 \rangle = \beta_{33}^I \varepsilon_I + \beta_{33}^{II} \varepsilon_{II}$$

Lattice functions at the entrance to a long straight with a coupling transformation. The value of β_{33}^I gives the contribution of the “horizontal” emittance to the vertical beam size.



Space Charge and Coupling Bumps



- Coupling bumps do not necessarily solve the problem: although they mitigate space charge effects, they can drive resonances that themselves lead to emittance growth.

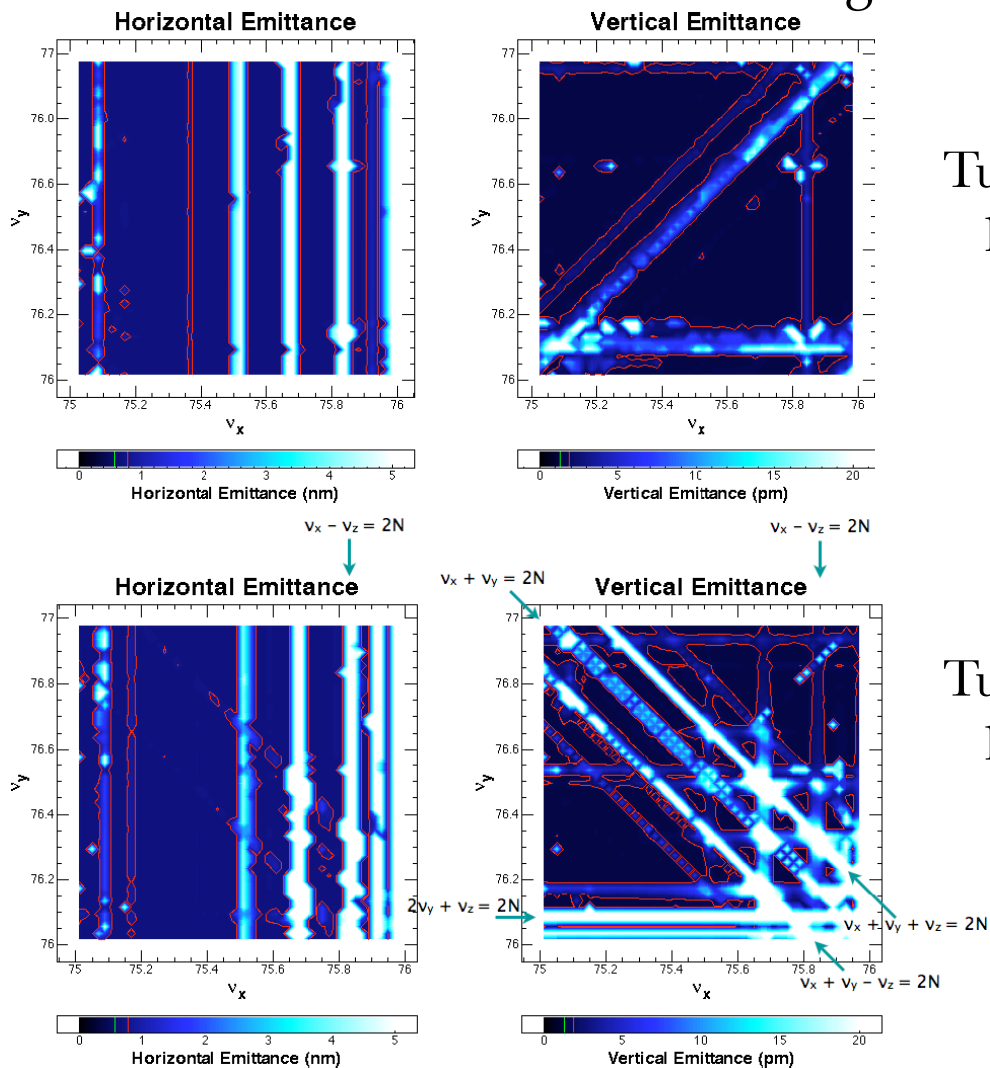

Tune scan of emittance growth in a 17 km lattice, with space charge, without coupling bumps.

Tune scan of emittance growth in a 17 km lattice, with space charge, and with coupling bumps.

$$\delta Q_{x,y} = - \frac{N_b r_e}{(2\pi)^{3/2} \gamma^3 \sigma_s} \oint \frac{\beta_{x,y}}{\sigma_{x,y} (\sigma_x + \sigma_y)} ds$$

$$\sigma_{s0} = \sigma_{p0} C \left(\frac{\alpha_p E}{2\pi h (V_0^2 - U_0^2)} \right)^{1/2}$$

$$\phi_s = \arcsin \left(\frac{U_0}{V_0} \right) \approx 70^\circ$$

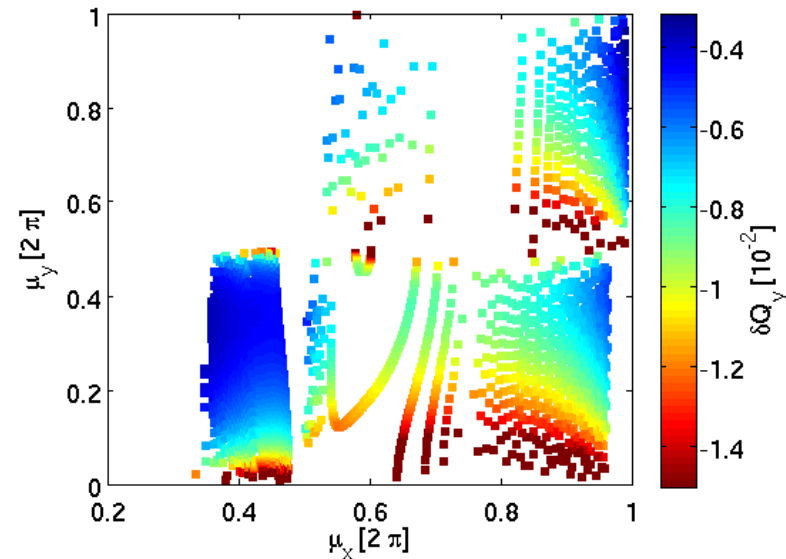
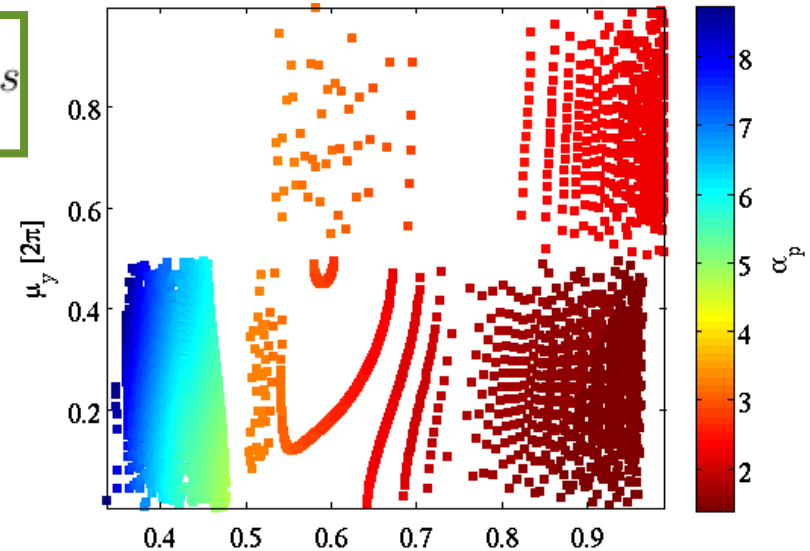

Contradiction

- Reduction of space charge tune shift \rightarrow Increase of bunch length
 - For same optics
- Increase of bunch length \rightarrow Increase of momentum compaction factor α_p or decrease of voltage V_0
- Decrease of voltage V_0 \rightarrow Increase the RF stationary phase ϕ_s



- Increasing α_p by raising the lattice detuning factor \rightarrow Larger dipole length (or smaller field) to keep the output emittance the same
- Positive impact on the longitudinal emittance
- Reduction of energy loss per turn and of the RF stable phase
- Achieve vertical space-charge tune-shift < 0.1

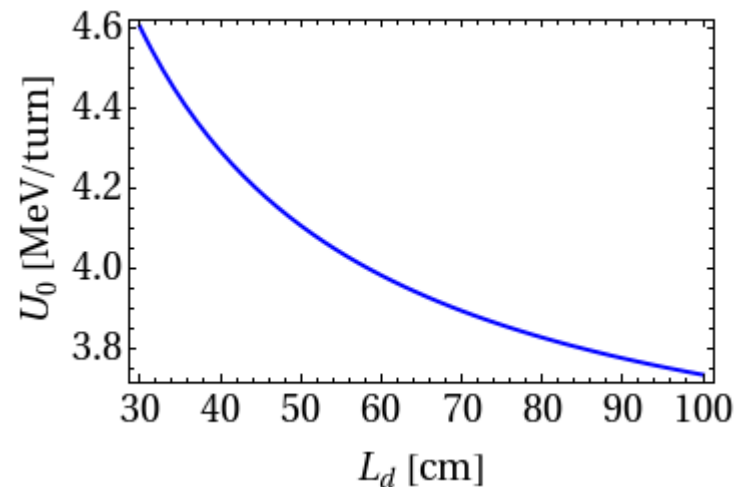

2013

Detuning Factor

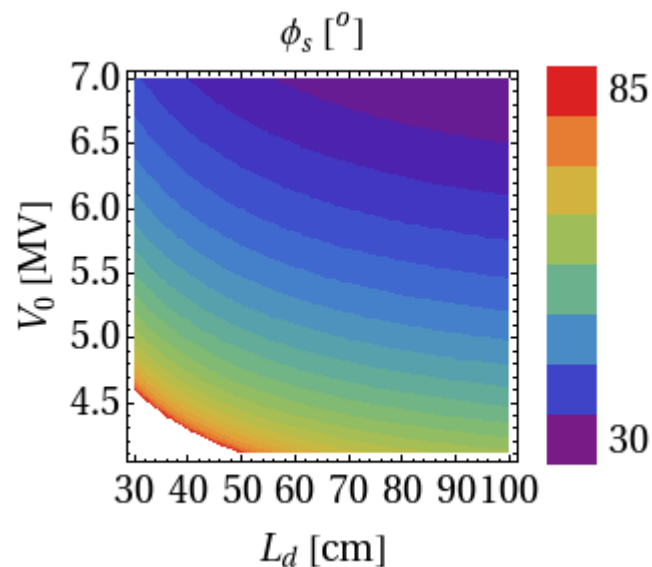
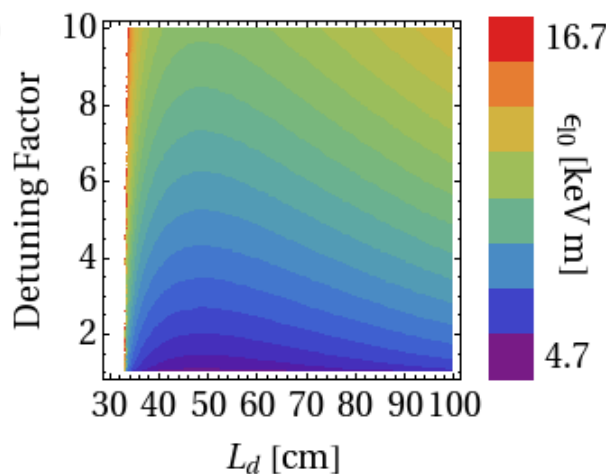
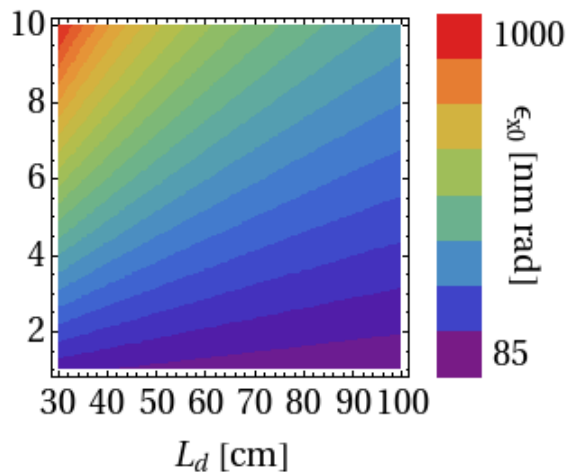

L



- Small angle **multiple Coulomb scattering** effect
 - Redistribution of beam momenta
 - Beam diffusion with impact on the beam quality
 - Brightness , luminosity, etc

- **Different approaches** for the probability of scattering
 - Classical Rutherford cross section
 - Quantum approach
 - Relativistic “Golden Rule” for the 2-body scattering process

- **Several theoretical models** and their **approximations** developed over the years → three main drawbacks:
 - Gaussian beams assumed
 - Betatron coupling not included
 - Impact on damping process?

Monte Carlo (MC) tracking codes can investigate these.



- Theoretical models calculate the **IBS growth rates**:

$$\frac{1}{T_i} = f(\text{optics}, \text{beam params})$$

- Complicated integrals averaged around the rings (see appendix)
 - Depend on optics and beam properties
- Classical models of Piwinski (**P**) and Bjorken-Mtingwa (**BM**)
 - Benchmarked with measurements for hadron beams but not for lepton beams in the presence of synchrotron radiation (SR) and quantum excitation (QE)
- High energy approximations **Bane** and **CIMP**
 - Integrals with analytic solutions
- Tracking codes **SIRE** and **CMAD-IBStrack**
 - Based on the classical approach



IBS calculations



Horizontal, vertical and longitudinal **equilibrium states** and **damping times** due to SR damping

The IBS growth rates in one turn (or one time step)

$$\frac{1}{T_i} = \langle f_i \rangle$$

Complicated integrals averaged around the ring.

$$\begin{aligned} \frac{d\varepsilon_x}{dt} &= -\frac{2}{\tau_x} (\varepsilon_x - \varepsilon_{x0}) + \frac{2\varepsilon_x}{T_x(\varepsilon_x, \varepsilon_y, \sigma_p)} \\ \frac{d\varepsilon_y}{dt} &= -\frac{2}{\tau_y} (\varepsilon_y - \varepsilon_{y0}) + \frac{2\varepsilon_y}{T_y(\varepsilon_x, \varepsilon_y, \sigma_p)} \\ \frac{d\sigma_p}{dt} &= -\frac{1}{\tau_p} (\sigma_p - \sigma_{p0}) + \frac{\sigma_p}{T_p(\varepsilon_x, \varepsilon_y, \sigma_p)} \end{aligned}$$

If = 0

Steady State emittances

If ≠ 0

Steady state exists if we are below transition or in the presence of SR .

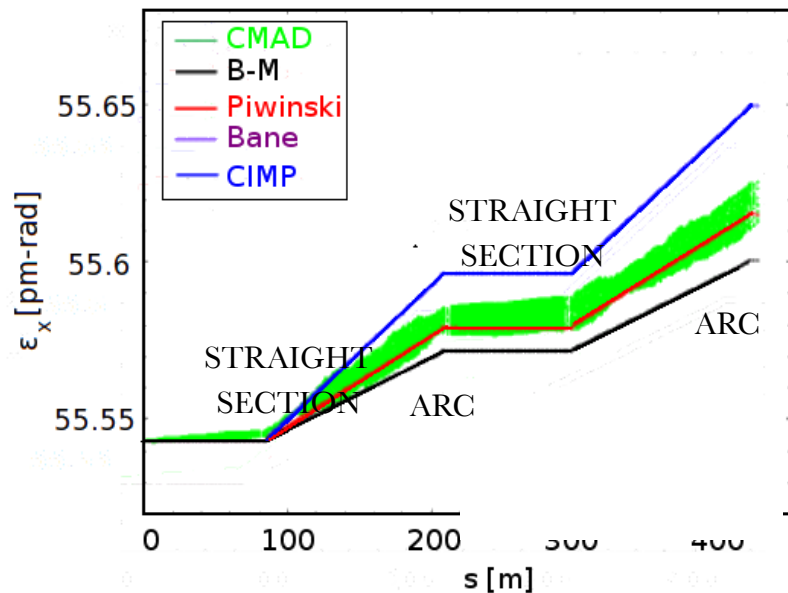
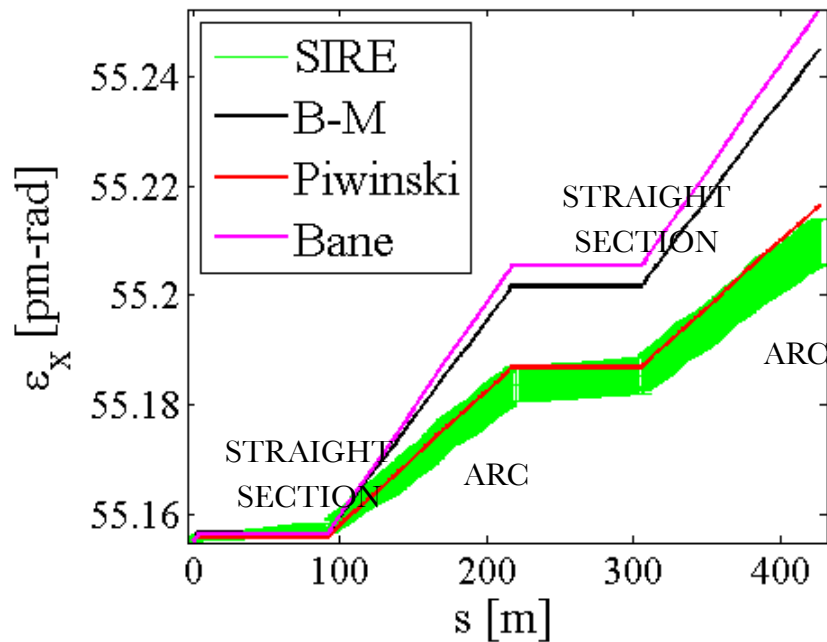

- SIRE (top) and CMAD-IBTrack (bottom) benchmarking with theoretical models for the CLIC DR lattice
 - 1 turn emittance evolution comparison
- Excellent agreement with Piwinski as expected
- All models and codes follow the **same trend** on the emittance evolution
- Clear **dependence** on the **optics**
 - Large contribution from the arcs

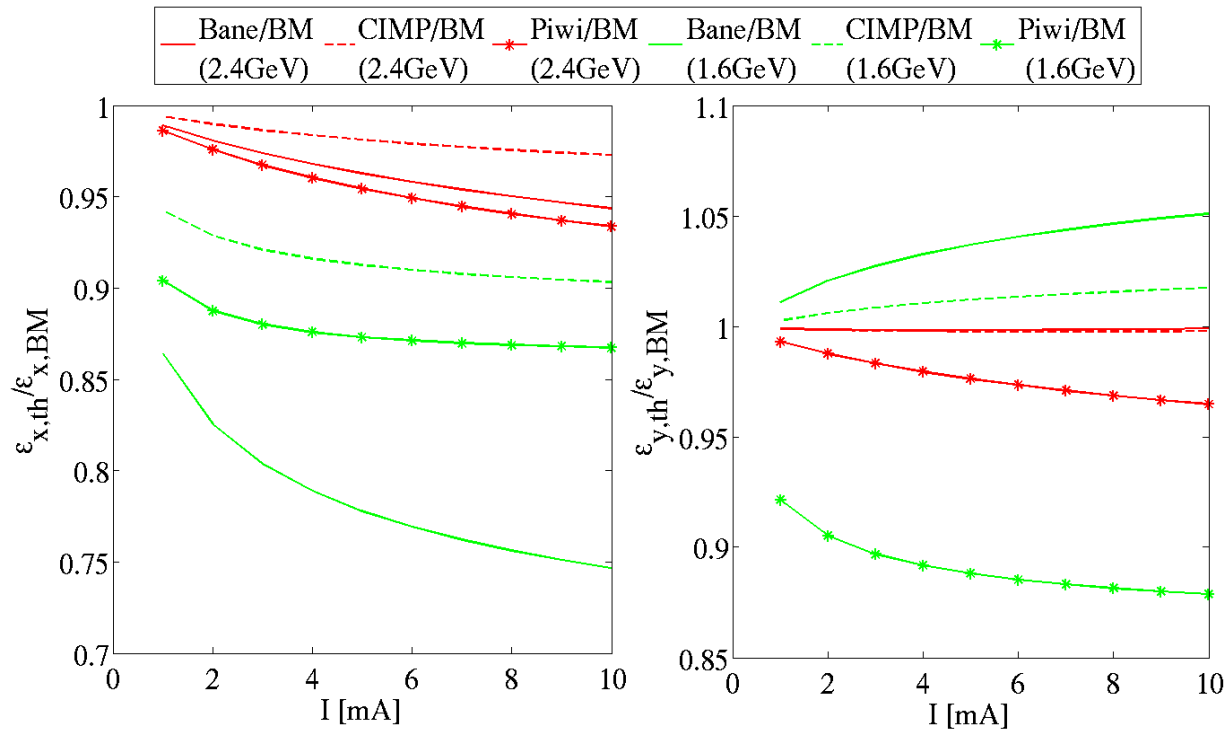

- Comparison between the theoretical models for the SLS lattice
- All results **normalized** to the ones from **BM**
- Good **agreement** at **weak** IBS regimes
- **Divergence** grows as the IBS effect **grows**
 - Benchmarking of theoretical models and MC codes with measurements is essential

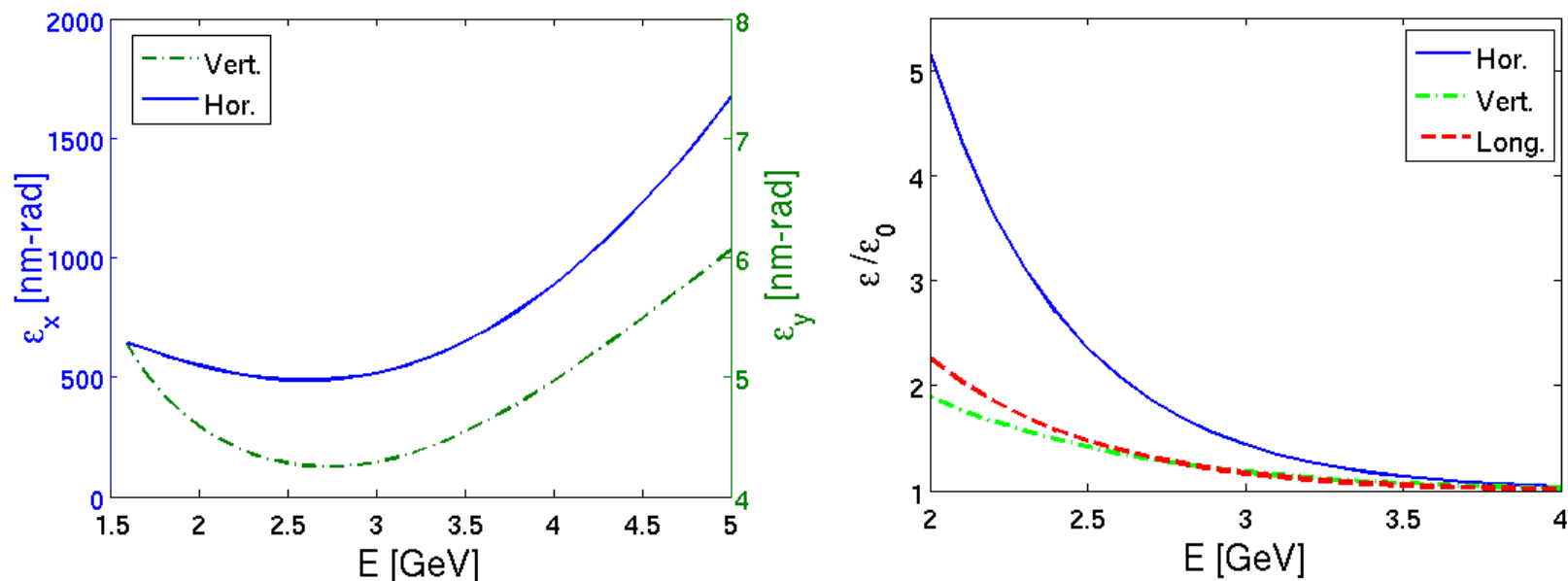

- **Scaling** of output transverse emittances with **energy** (taking into account IBS)
- Broad minimum of the emittances around 2.5 GeV (left) while the IBS effect becomes weaker with energy (right)
 - Higher energies are interesting for IBS but not for the emittance requirements
- **Energy increase** (2.424 \rightarrow 2.86 GeV) \rightarrow **reduction of the IBS effect** by a factor of 2 (3 \rightarrow 1.5)

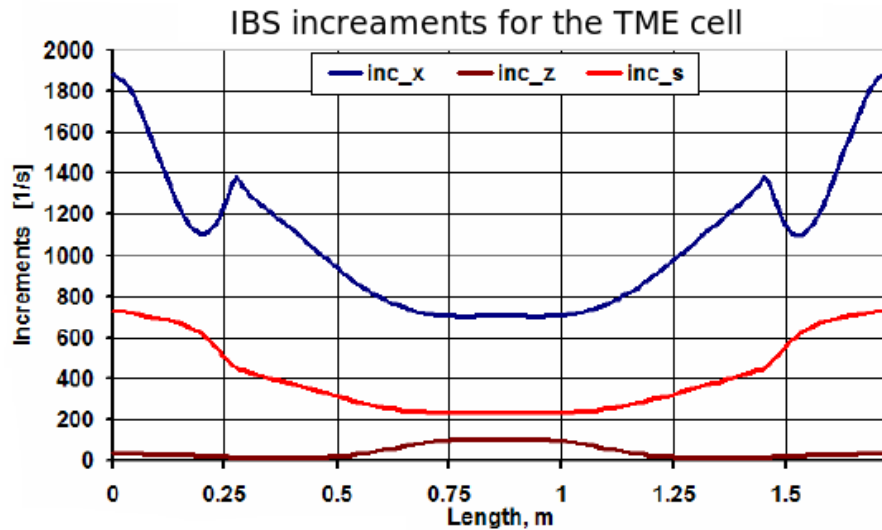

- IBS increments of a nominal TME cell

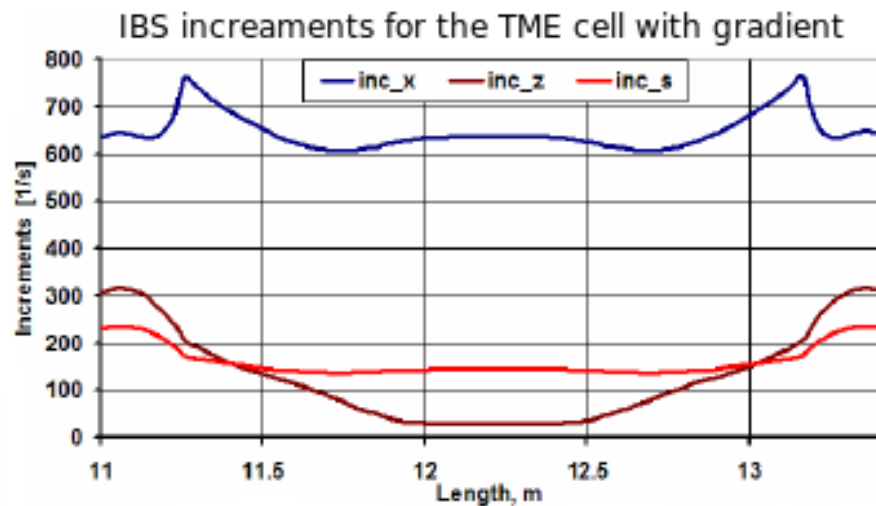

- IBS increments of a TME cell with gradient in the dipole
 - Reduction of the IBS increments by a factor of 3

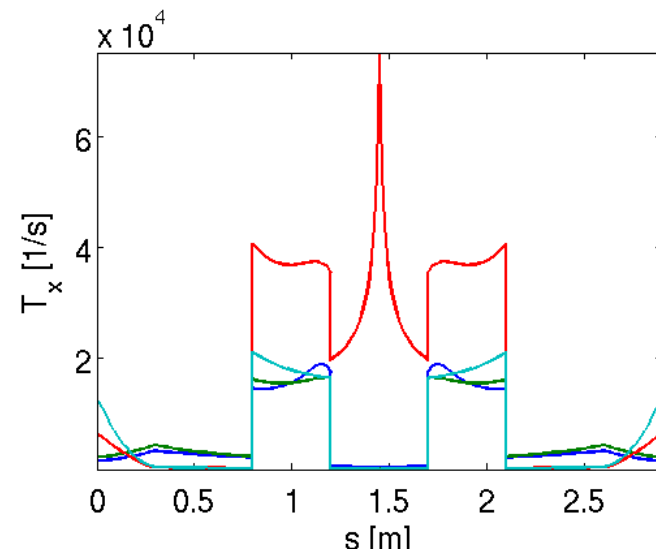
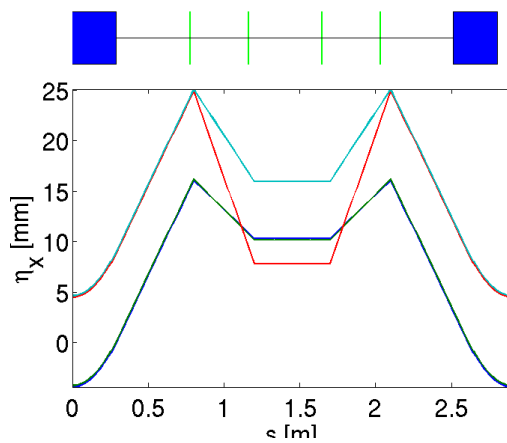
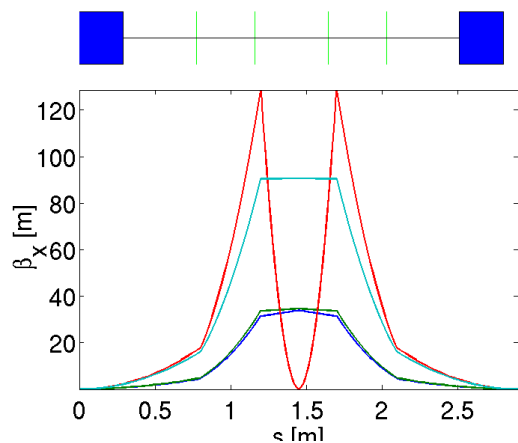

- For the same detuning factor (here $\varepsilon_r=6$) **different optics options** (top plots)
- The corresponding horizontal and longitudinal growth rates along a TME cell (right plots)
- **Careful optics choice very important for the IBS optimization**

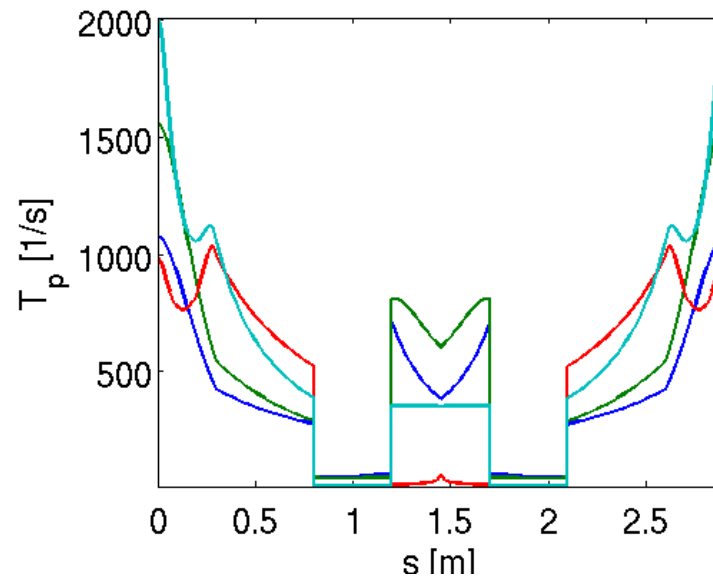

TME optimization for IBS

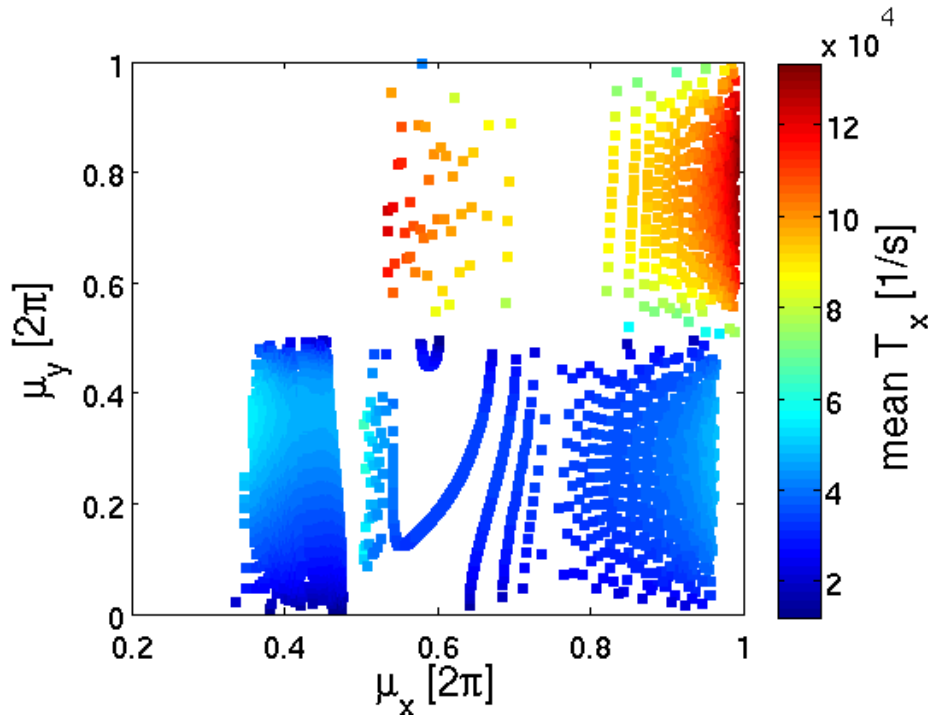

- Scanning on the detuning factor ($\varepsilon_r=1..25$) \rightarrow low phase advances optimal for IBS growth rate minimization
 - As for the chromaticity and space charge detuning

- Interesting regions according to the requirements of the design
- For $D_y=0 \rightarrow T_y=0$ computed by Bane

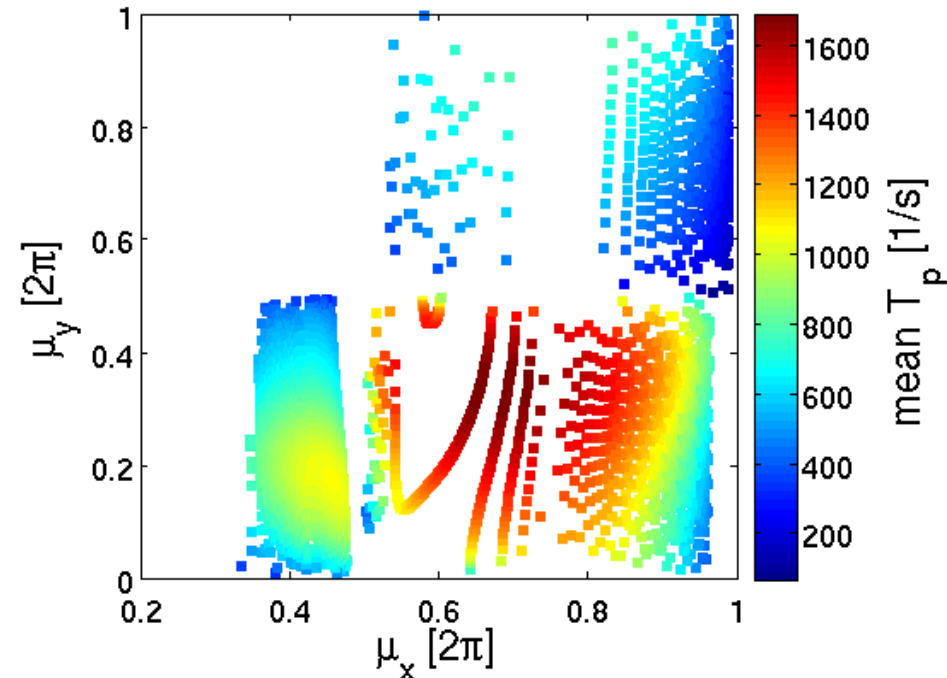

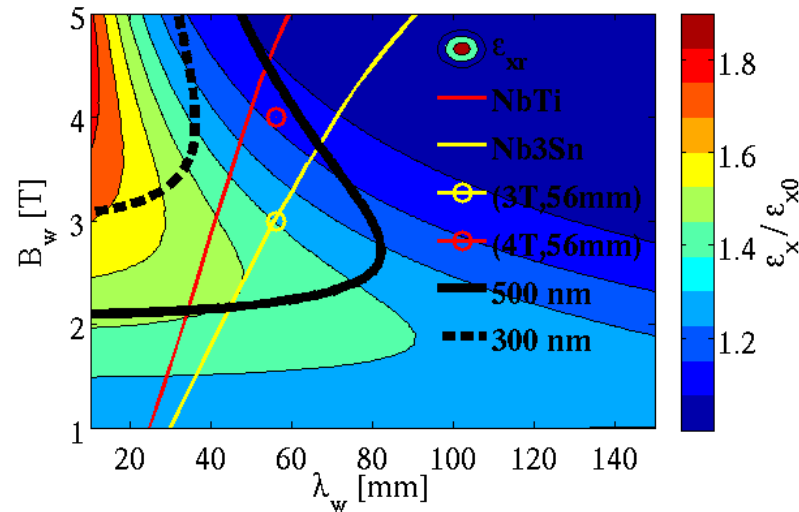
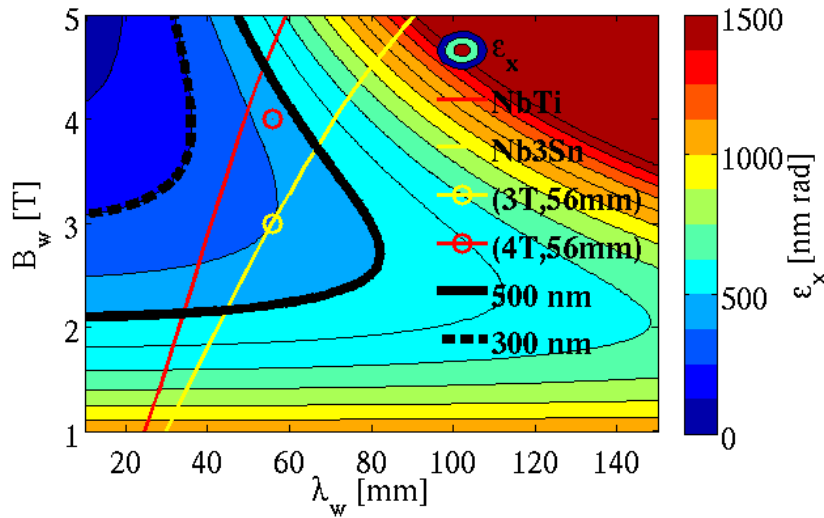

- The output **emittance** is **minimized** at large wiggler peak fields and small wiggler periods → The **IBS effect** is **maximized** in this regime
- Large wiggler peak fields and **moderate wiggler periods** are interesting for low emittance and **reduced IBS effect**
- **Superconducting wigglers** can achieve the high fields required for the emittance requirement
 - **Nb3Sn** & **NbTi** technologies



Touschek scattering



- The Touschek effect refers to scattering events in which there is a large transfer of momentum from the transverse to the longitudinal planes.
- IBS refers to multiple small-angle scattering
- Touschek effect refers to single large-angle scattering events
- If the change in longitudinal momentum is large, energy deviation of particles can be outside the energy acceptance, and the particles are lost
- Particle loss from the Touschek effect tends to be the dominant limitation on beam lifetime in low-emittance rings
- During regular operations, any given bunch is stored in the damping rings for only tens of ms and thus Touschek scattering may not be an operational limitation for DR
- However, during commissioning and tuning, there are likely to be situations where beam stored for a long periods may be needed
- So reasonable Touschek lifetime is important

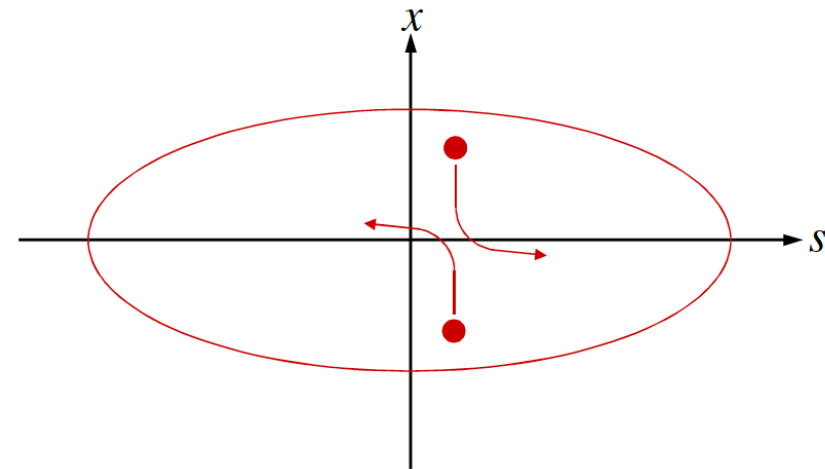



Touschek lifetime



- We just quote the result of the lifetime

$$\frac{1}{\tau} = -\frac{1}{N} \frac{dN}{dt} = \frac{r_e^2 c N}{8\pi\sigma_x \sigma_y \sigma_z \gamma^2 \delta_{\max}^3} D\left(\left[\frac{\delta_{\max} \beta_x}{\gamma\sigma_x}\right]^2\right)$$

where N is the number of particles in a bunch, σ_x , σ_y , σ_z are the rms horizontal and vertical beam sizes and bunch length, and δ_{\max} is the energy acceptance of the ring

- Note that the energy acceptance may be limited by the RF acceptance (which depends on the RF voltage, and is typically a few % or more) or by the nonlinear dynamics (which may give a limitation as low as 1%).
- The function $D(\epsilon)$ is given by:

$$D(\epsilon) = \sqrt{\epsilon} \left[-\frac{3}{2} e^{-\epsilon} + \frac{\epsilon}{2} \int_{\epsilon}^{\infty} \frac{\ln u}{u} e^{-u} du + \frac{1}{2} (3\epsilon - \epsilon \ln \epsilon + 2) \int_{\epsilon}^{\infty} \frac{e^{-u}}{u} du \right]$$

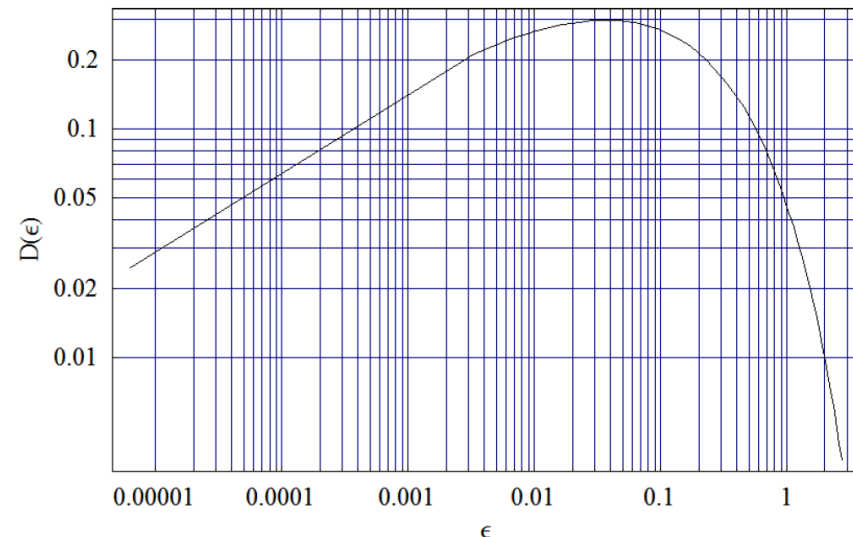

- The energy acceptance is generally a function of position in the lattice
- However, a rough estimate can be made of the expected lifetime by assuming a fixed energy acceptance of 1%
- Note that, in the parameter regime ($\epsilon \ll 1$) relevant for the damping rings

$$D(\epsilon) \propto \sqrt[3]{\epsilon} \quad \text{and} \quad \tau \propto \delta_{\max}^2$$

Lattice	Beam energy	Particles per bunch	Bunch length	Touschek lifetime
OCS	5 GeV	2×10^{10}	6 mm	33 min
BRU	3.74 GeV	2×10^{10}	9 mm	18 min
MCH	5 GeV	2×10^{10}	9 mm	68 min
TESLA	5 GeV	2×10^{10}	6 mm	50 min



- Particles can interact directly with each other (space charge IBS).
- Particles in a bunch can also interact indirectly, via the vacuum chamber.
 - The electromagnetic fields around a bunch must satisfy Maxwell's equations.
 - The presence of a vacuum chamber imposes boundary conditions that modify the fields.
 - Fields generated by the head of a bunch can act back on particles at the tail, modifying their dynamics and (potentially) driving instabilities.

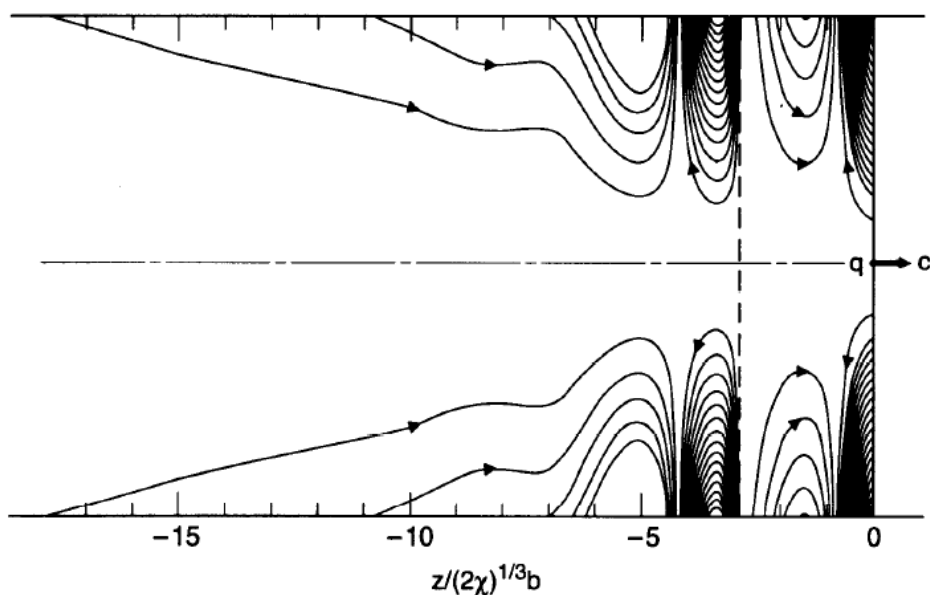

Wake fields following a point charge in a cylindrical beam pipe with resistive walls

- Finding analytical solutions for the field equations is possible in some simple cases. Generally, one uses an electromagnetic modeling code to solve numerically for a given bunch shape in a specified geometry.
- It is useful to determine the “wake function” $W_{//}(z)$, $W_{\perp}(z)$ for a given component, which gives the field behind a point unit charge integrated over the length of the component. For a bunch distribution $\lambda(z)$:

$$\Delta\delta(z) = -\frac{r_e}{\gamma} \int_z^{\infty} \lambda(z') W_{//}(z - z') dz'$$

$$\Delta p_y(z) = -\frac{r_e}{\gamma} \int_z^{\infty} y(z') \lambda(z') W_{\perp}(z - z') dz'$$

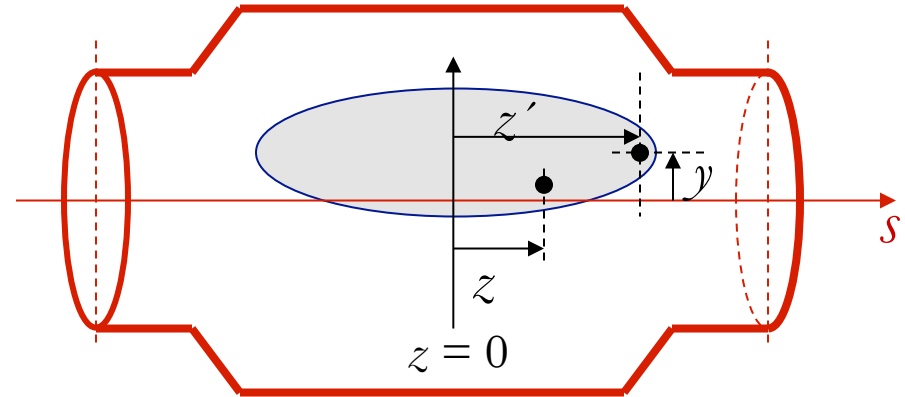

where $\delta(z)$ is the energy deviation of a particle at position z in the bunch, and $p_y(z)$ is the normalized transverse momentum of a particle at position z in the bunch.

- Wake functions are also found numerically, by solving Maxwell's equations

- Consider longitudinal wake, averaged over an entire ring
- Suppose that the storage ring is filled with unbunched beam so that the particle density is:

$$\lambda(z) = \lambda_0 + \lambda_\omega \exp\left(i \frac{\omega z}{c}\right)$$

- The energy change of a particle in one turn is:

$$\Delta\delta(z) = -\frac{r_e}{\gamma} \int_z^\infty \lambda(z') W_{||}(z-z') dz' = -\frac{r_e}{\gamma} \int_z^\infty \left(\lambda_0 + \lambda_\omega e^{i \frac{\omega z'}{c}} \right) W_{||}(z-z') dz' = \frac{r_e c}{\gamma} e^{i \frac{\omega z}{c}} \lambda_\omega Z_{||}(\omega)$$

where we have defined the **impedance**: $Z_{||}(\omega) = \frac{1}{c} \int \exp\left(-i \frac{\omega z}{c}\right) W_{||}(z) dz$
and we assume that $Z_{||}(0) = 0$

- The change in energy deviation per turn is: $\Delta\delta(z) = \frac{r_e c}{\gamma} e^{i \frac{\omega z}{c}} \lambda_\omega Z_{||}(\omega)$

which can be written:
$$\frac{\Delta E(z)}{e} = I(\omega; z) Z_{||}(\omega)$$

or, in other words, $V = I Z$, just as one would expect from an impedance

- What needs to be evaluated is the effect of the impedance on the beam

- The evolution of the beam distribution $\Psi(\theta, \delta; t)$ obeys the **Vlasov** equation:

$$\frac{\partial \Psi}{\partial t} + \dot{\theta} \frac{\partial \Psi}{\partial \theta} + \dot{\delta} \frac{\partial \Psi}{\partial \delta} = 0$$

where θ is the azimuthal coordinate in the accelerator (i.e. distance around the ring, in radians).

- Assume that the distribution is uniform in energy, plus some perturbation of defined frequency

$$\Psi(\theta, \delta; t) = \Psi_0(\delta) + \Delta\Psi_n(\delta) e^{i(n\theta - \omega_n t)}$$

- The time derivatives of azimuthal coordinate and energy deviation are

$$\dot{\theta} = \omega_0 (1 + \alpha_p \delta), \quad \dot{\delta} = Z_{//}(\omega_n) \frac{I_0}{E/e} \frac{\omega_0}{2\pi} \left[\int \Delta\Psi_n(\delta) d\delta \right] e^{i(n\theta - \omega_n t)}$$

- The goal is to find the **mode frequency** ω_n giving the time evolution of the perturbation.
- If ω_n has a positive imaginary part, then the beam distribution is unstable and the perturbation will grow exponentially with time.



- Substituting into the Vlasov equation and expanding to first order in the perturbation $\Delta\Psi$, the following relationship is obtained:

$$(n\omega_0 - \omega_n)\Delta\Psi(\delta) = iZ_{//}(\omega_n) \frac{I_0}{E/e} \frac{\omega_0}{2\pi} \frac{\partial\Psi_0}{\partial\delta} \int \Delta\Psi_n(\delta) d\delta$$

- Integrating both sides over δ , we find the **dispersion relation**:

$$1 = iZ_{//}(\omega_n) \frac{I_0}{E/e} \frac{\omega_0}{2\pi} \int \frac{\partial\Psi_0 / \partial\delta}{n\omega_0 - \omega_n} d\delta$$

- The dispersion relation is an integral equation which associates the mode frequency ω_n , to a given impedance $Z_{//}(\omega)$
- Solving Vlasov equation is not an easy task and rely numerical and analytical techniques
- Numerical techniques are often more satisfactory, since they allow one to study the dynamics including a detailed description of the impedance (e.g. by modeling the vacuum chamber)
- When a detailed description of the impedance is not available, rely on scaling laws for first crude estimates

- Using the dispersion relation, and making some crude assumptions about the form of the impedance (and considering bunched beams)

$$\frac{Z_{||}}{n} > Z_0 \sqrt{\frac{\pi}{2}} \frac{\gamma \alpha_p \sigma_\delta^2 \sigma_z}{N_0 r_e}$$

- This is the Keill-Schnell-Boussard criterion.
- It gives the threshold of an instability which appears as a density modulation in the beam, where the wavelength of the modulation is C/n (for ring circumference C).
- The impedance is characterized as $Z(n\omega_0)/n = \text{constant}$ which is a quite crude approximation
- If either of α_p (the momentum compaction), or σ_δ (the energy spread) is zero, then the beam is unstable.
- Having non-zero values for these quantities stabilizes the beam through **Landau damping**.
- As the density modulation develops, it tends to be smeared out because particles with different energies (σ_δ) move around the ring at different rates (α_p), which tends to “smear out” the modulation.

- The microwave instability is observed as an increase in energy spread
- It has to be avoided in DRs, because any increase in longitudinal emittance will make operation of the bunch compressors difficult.
- An instability can also appear in a “bursting” mode: a dramatic increase in energy spread occurs and damps down, before growing again
- SLC damping rings had significant problems due to this instability

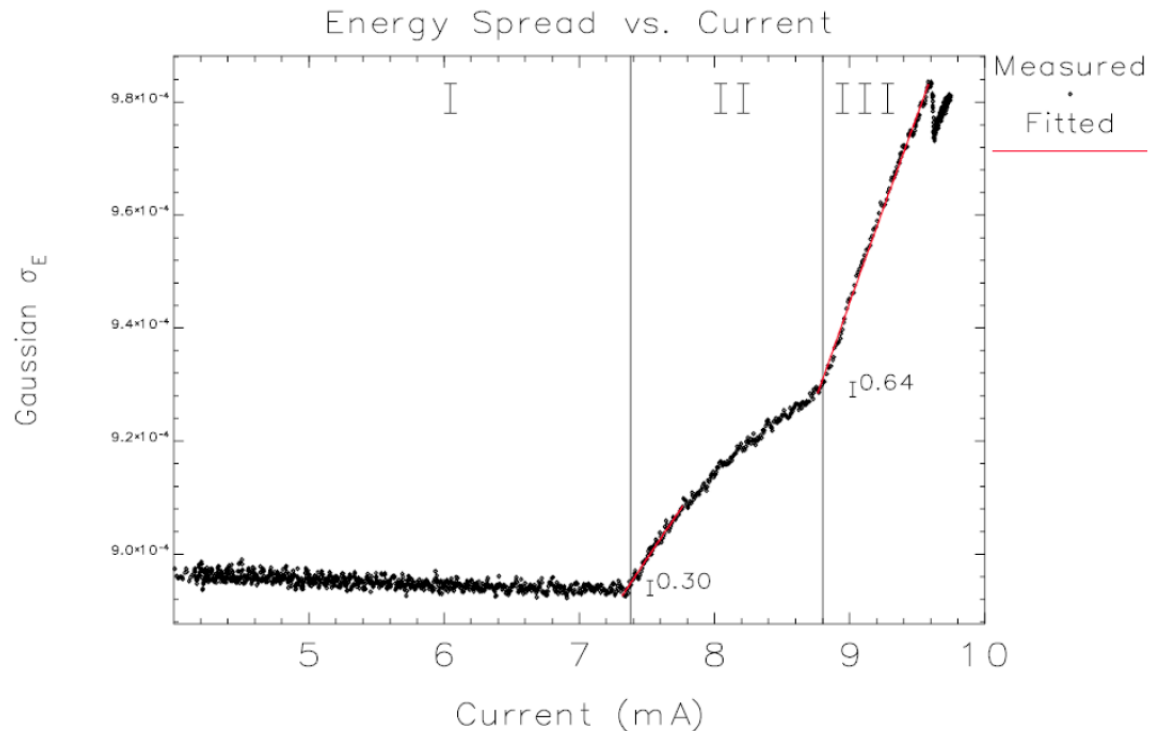

Y.-C. Chae et al, "Measurement of the longitudinal microwave instability in the APS storage ring", Proceedings of the 2001 Particle Accelerator Conference, Chicago (2001).

- To avoid the microwave instability, the options are:
- Increase the bunch length and energy spread to reduce the peak current
 - There is an upper limit set by bunch compressors
- Raise the beam energy
 - This increases costs and the equilibrium emittances.
- Reduce the bunch charge
 - The bunch charge is set by the luminosity requirements
- Increase the momentum compaction factor
 - A very high RF voltage is needed to achieve the specified bunch length.
 - Synchrotron tune becomes large (problems with synchro-betatron resonances)
- Low Impedance design
 - Longitudinal Impedance thresholds of a few hundreds of mΩ may be quite challenging

Lattice	Energy	α_p	σ_δ	σ_z	N_0	Impedance threshold
OCS	5 GeV	1.62×10^{-4}	1.29×10^{-3}	6 mm	2×10^{10}	134 mΩ
BRU	3.74 GeV	11.9×10^{-4}	0.97×10^{-3}	9 mm	2×10^{10}	622 mΩ
MCH	5 GeV	4.09×10^{-4}	1.30×10^{-3}	9 mm	2×10^{10}	510 mΩ
TESLA	5 GeV	1.22×10^{-4}	1.29×10^{-3}	6 mm	2×10^{10}	100 mΩ

- As well as **short-range wakefields** acting over the length of a single bunch, there are also **long-range wakefields** that act over multiple bunches.
- Principal sources of long-range wakefields are:
 - Resistive-wall wakefield, resulting from modifications to the fields in vacuum chambers when the walls of the chamber are not perfectly conducting.
 - Higher-order modes (HOMs) in the RF cavities (and other chamber cavities). Oscillations of the E/M fields in cavities are excited by a bunch passage; modes with high Q damp slowly, and can persist from one bunch to the next.
- Resistive-wall wakefields depend on vacuum chamber geometry (larger chambers have lower wakefields) and material (better conducting materials have lower wakefields).
- Cavity HOMs depend principally on the geometry, and vary significantly from one design to another. Various techniques are used in cavity design to damp the HOMs to acceptable levels.
- The effects of long-range wakefields include the growth of coherent oscillations of the individual bunches, with growth rates depending on the fill pattern and beam current.
- In high-current rings, feedback systems are needed to suppress the coherent motion of the bunches, thereby keeping the beam stable.

Coupled-Bunch Instabilities

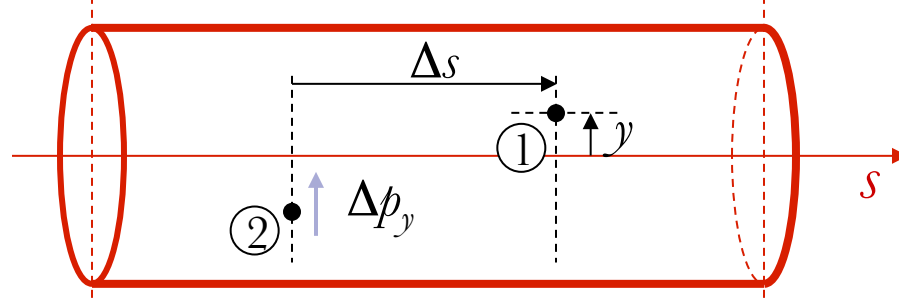

- Kick on the trailing particle (2) can be described from the wakefield of the leading particle (1) in terms of a wake function (N_0 is the bunch charge):

$$\Delta p_{y,2} = -\frac{r_e}{\gamma} N_0 W_{\perp}(-\Delta s) y_1$$

- In a storage ring containing M bunches, the equation of motion is

$$\ddot{y}_n(t) + \omega_{\beta}^2 y_n(t) = -\frac{r_e}{\gamma} \frac{c}{T_0} N_0 \sum_k \sum_{m=0}^{M-1} W_{\perp} \left(-kC - \frac{m-n}{M} C \right) y_m \left(t - kT_0 - \frac{m-n}{M} T_0 \right)$$

Betatron oscillations

Multiple turns

Multiple bunches

- Substituting a solution of this form $y_n(t) = \exp\left(2\pi i \frac{\mu n}{M}\right) \exp(-i\Omega_{\mu} t)$

an equation is derived for the mode frequency Ω_{μ} corresponding to given mode number μ .

- The imaginary part of Ω_{μ} gives the instability growth (or damping) rate

Coupled-Bunch Instabilities

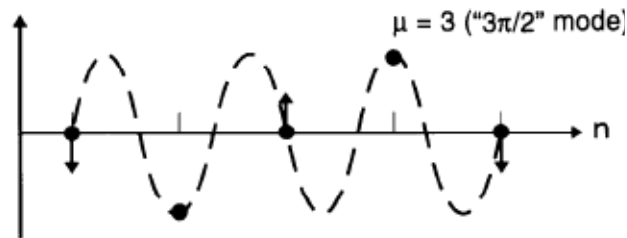
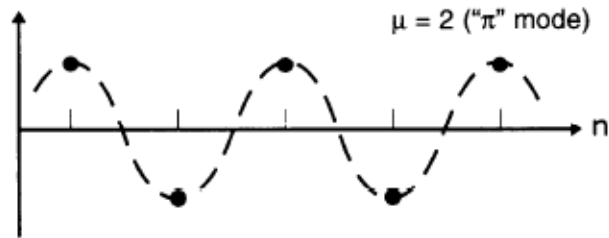
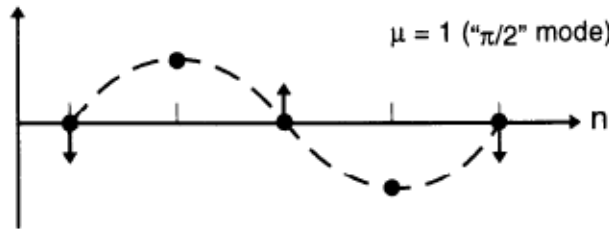
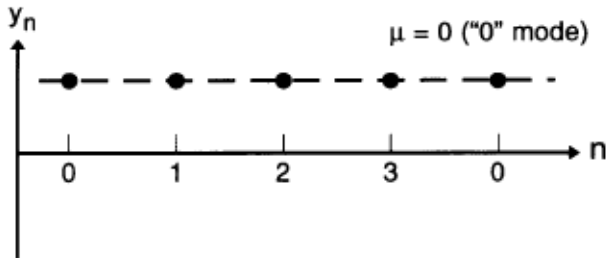

- In a coupled-bunch instability, the bunches perform coherent oscillations.
- The mode number μ gives the phase advance from one bunch to the next at a given moment in time.
- The examples here show the modes ($\mu = 0, 1, 2$ and 3) in an accelerator with $M = 4$ bunches.

From A. Chao, "Physics of Collective Beam Instabilities in Particle Accelerators," Wiley (1993).

- The transverse resistive-wall wake-field for a chamber with length L and circular cross-section of radius b is given (for $z < 0$) by:

$$W_{\perp}(z) = \frac{2}{\pi} \sqrt{\frac{c}{\sigma_c}} \frac{L}{b^3} \frac{1}{\sqrt{-z}}$$

- Implications for the damping rings are:
 - Beam pipe radius must be as large as possible to keep the wakefields small - note that the wakefield (and hence the growth rates) vary as $1/b^3$;
 - Beam pipe constructed from material with good electrical conductivity (e.g. aluminum) to keep wakefields small - note that the wakefields vary as $1/\sqrt{\sigma_c}$



- For the resistive-wall instability, the growth (damping) rate for the fastest mode is found to be:

$$\frac{1}{\tau^{(\mu)}} \approx - \frac{MN_0 r_e c^2}{b^3 \gamma \omega_\beta T_0 \sqrt{2\pi\sigma_c \omega_0}} \frac{\text{sgn}(\Delta_\beta)}{\sqrt{|\Delta_\beta|}}$$

where M is the total number of bunches, N_0 is the number of particles per bunch, r_e is the classical radius of the electron, b is the beam-pipe radius, γ is the relativistic factor at the beam energy, ω_β is the betatron frequency, T_0 is the revolution period, σ_c is the conductivity of the vacuum chamber material, ω_0 is the revolution frequency.

- Also, if ν_β is the betatron tune, and N_β is the integer closest to ν_β , then:

$$\nu_\beta = N_\beta + \Delta_\beta \quad -\frac{1}{2} < \Delta_\beta \leq \frac{1}{2}$$

- If Δ_β is positive (tune below the half-integer), then fastest mode is damped
- if Δ_β is negative (tune above the half-integer), then the fastest mode is antidamped
- It therefore helps if the lattice has betatron tunes that are below the half-integer.

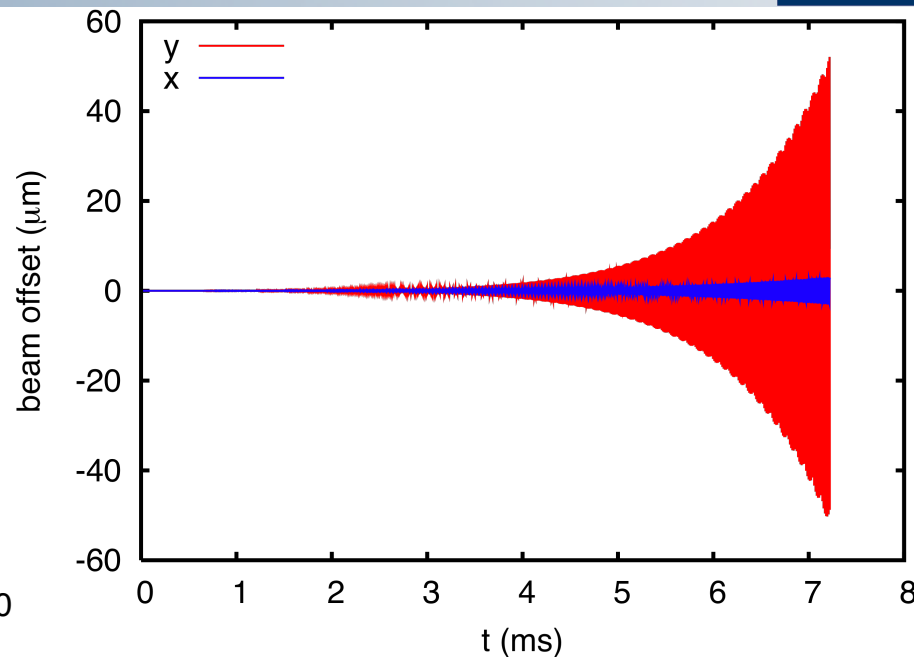
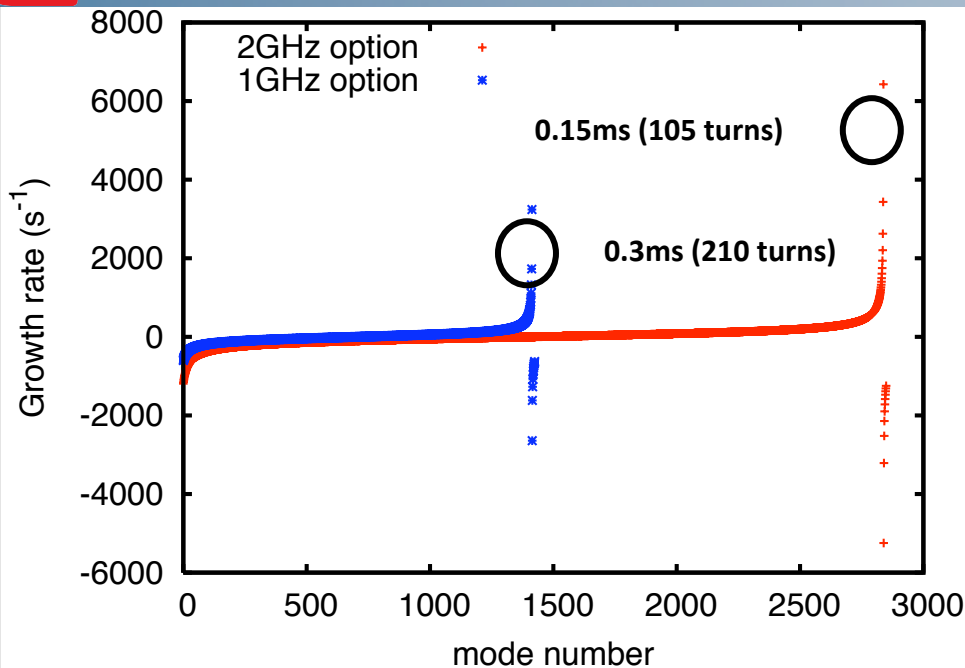

- Pessimistic estimate because wigglers only cover half of the ring, which gives possibly a factor 2
- Instability rate has to be scaled by n_b/M , because the formulae assume a uniformly filled ring.
- Headtail simulations show that the evolution of the vertical centroid of the train exhibits an exponential growth in both the horizontal (slow) and vertical (fast) plane
- **Rise time** is larger than calculated one by about a factor 5-10, because simulation takes into account real wiggler length and train structure



- In e^- damping ring, ions that are generated by the bunches interacting with the particle beam can be trapped by the fields of the beam resulting in high concentrations of positive ions near the beam axis
- The interaction of the beam with these ions can then lead to the onset of beam instabilities
- There are generally 2 classes of ion effects that are discussed in the context of an electron storage ring:
 - For rings that are uniformly filled with electron bunches, the ions can build up over many turns
 - This effect is known as ion trapping
 - It can be mitigated by placing large “clearing” gaps in the bunch train during which the ions drift away from beam axis and escape potential well formed by the beam
 - Clearing electrodes have also been used to help mitigate the ion build-up
 - A more serious effect for the damping rings is the rapid build-up of the ion density along the bunch train during a single passage
 - This is known as the fast ion instability
 - This is expected to be a significant issue for the electron damping ring



- For an ion in the proximity of the beam, the electric fields of the bunches create a focusing force which acts on the ion and serves trap it near the beam axis.

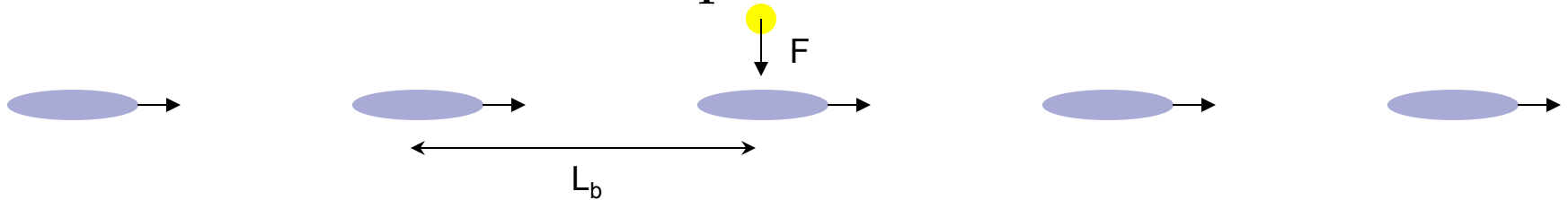

- The effective k-value of this focusing force is given by:

$$k = \frac{2r_p N_0}{A\sigma_y(\sigma_x + \sigma_y)}$$

where A is the atomic mass of the ion, r_p is the classical radius of the proton, and N_0 , σ_x and σ_y are the bunch charge and transverse sizes of the electron beam.



- The motion of the of the ion during the passage of one bunch can be expressed in terms of transfer matrices:

$$\mathbf{M} = \begin{pmatrix} 1 & s_b \\ 0 & 1 \end{pmatrix} \cdot \begin{pmatrix} 1 & 0 \\ -k & 1 \end{pmatrix} = \begin{pmatrix} 1 - s_b k & s_b \\ -k & 1 \end{pmatrix}$$

- The stability criteria is then:

$$\text{Trace}(\mathbf{M}) \leq 2 \quad \text{or} \quad A \geq \frac{r_p N_0 s_b}{2\sigma_y (\sigma_x + \sigma_y)}$$

- Having high bunch charges or very small beam sizes increases the mass for which ion trapping will take place.
- For DRs, where beam sizes change dramatically through damping cycle, it means that mass of ions that can be trapped will change continuously
- This effect can be mitigated by having large gaps in the electron bunch train.

Growth time estimates with train gaps

The central ion density, and hence the instability rate, is reduced by a factor of 60 compared with a fill consisting of a single long train

$$IRF = \frac{1}{N_{train}} \frac{1}{1 - \exp(-\tau_{gap} / \tau_{ions})}$$

118 trains

Larger number of trains, longer gap and a smaller emittance help!

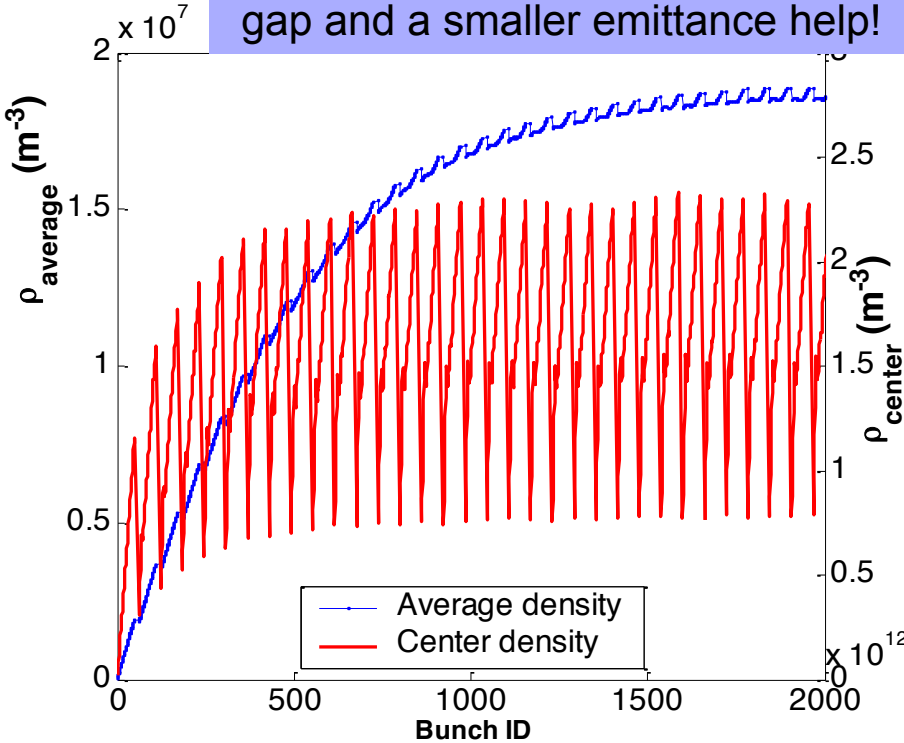
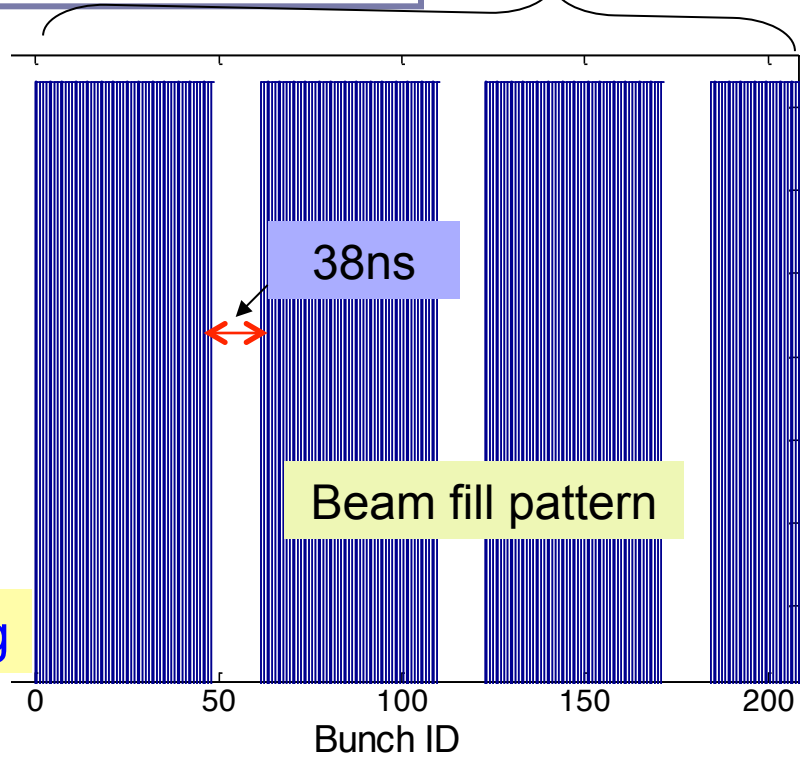

Build-up of CO+ ion cloud at extraction (with equilibrium emittance). The total number of bunches is 5782, P=1 nTorr. Growth time > 10 turns. Can be handled with a fast feedback system.



- If the pressure in the pipe of the CLIC transport line exceeds 0.1 nTorr, the fast ion instability sets in
- We can also diagnose the instability by looking at the evolution of the centroid motion over subsequent parts of the train (1/3).
- It is usually assumed that a number of rise times below ≈ 3 along the line is acceptable in order not to degrade the beam significantly.

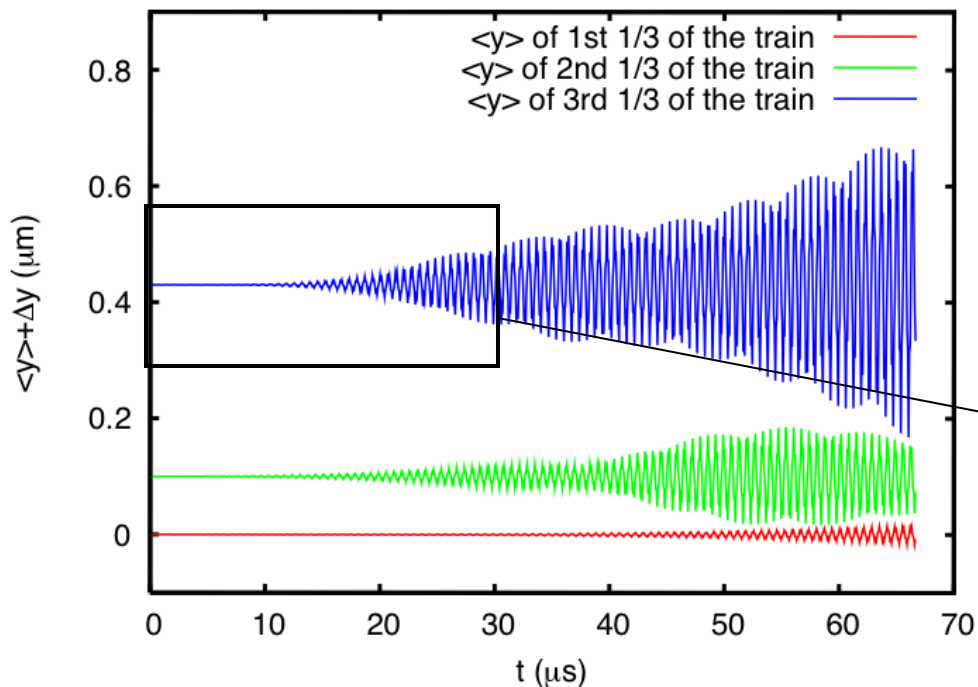

$$y_e(t) \propto \left(\frac{t}{\tau}\right)^{-\frac{1}{4}} \exp\left(\sqrt{\frac{t}{\tau}}\right)$$

~ 6 „e-folding“ times

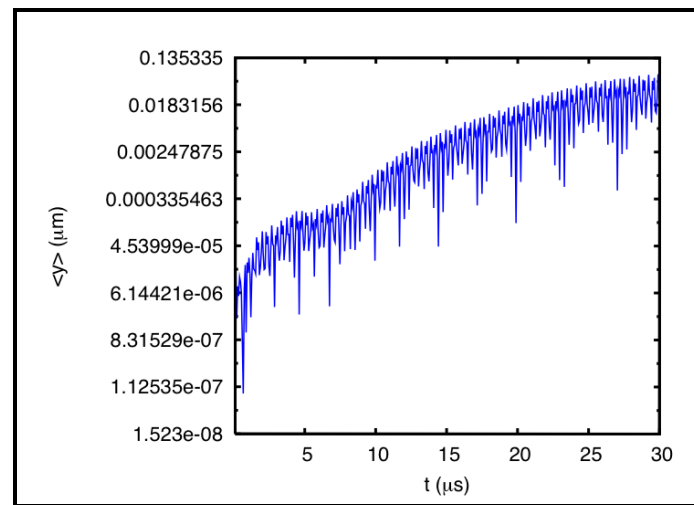



- Usually existing machines (especially light sources) operate with large enough gaps as to clear away the ions and avoid conventional instabilities
- Other techniques used to clear the ions are:
 - Static electrodes
 - Alternating field electrodes excited on the bounce frequency of the ions
 - Beam shaking
- Beam parameters and vacuum pressures are such that the present rings do not suffer from fast ion instability. However, this instability has been observed by injecting gas on purpose (e.g. ALS injected 25 nTorr He compared to 1 nTorr normal pressure) or, in some rings, during the commissioning phase, when the pressure had not yet reached its nominal value
- For DRs machines, with designs oriented towards ultra-low emittances and high beam currents (both damping rings for linear colliders or even transport lines and linacs), the fast ion instability is one of the most serious concerns and usually dictates the vacuum specifications

- Electron cloud effects in positron rings are analogous to ion effects in electron rings. During the passage of a bunch train, electrons are generated by a variety of processes (photoemission, gas ionization, secondary emission). Under certain circumstances, the density of electrons in the vacuum chamber can reach levels that are high enough to affect significantly the dynamics of the positrons. When this happens, an instability can be observed.
- In positron damping rings, the build-up of electron cloud is usually dominated by secondary emission, in which primary electrons are accelerated in the beam potential, and hit the walls of the vacuum chamber with sufficient energy to release a number of secondaries.
- The critical parameters for the build-up of the electron cloud are:
 - Charge of the electron bunches;
 - The separation between the electron bunches;
 - The properties of the vacuum chamber (particularly, the number of secondary electrons emitted per incident primary electron = the *Secondary Emission Yield* or SEY);
 - The presence of a magnetic or electric field (e-cloud can be worse in dipoles and wigglers);
 - The beam size (which affects the energy with which electrons strike the walls).

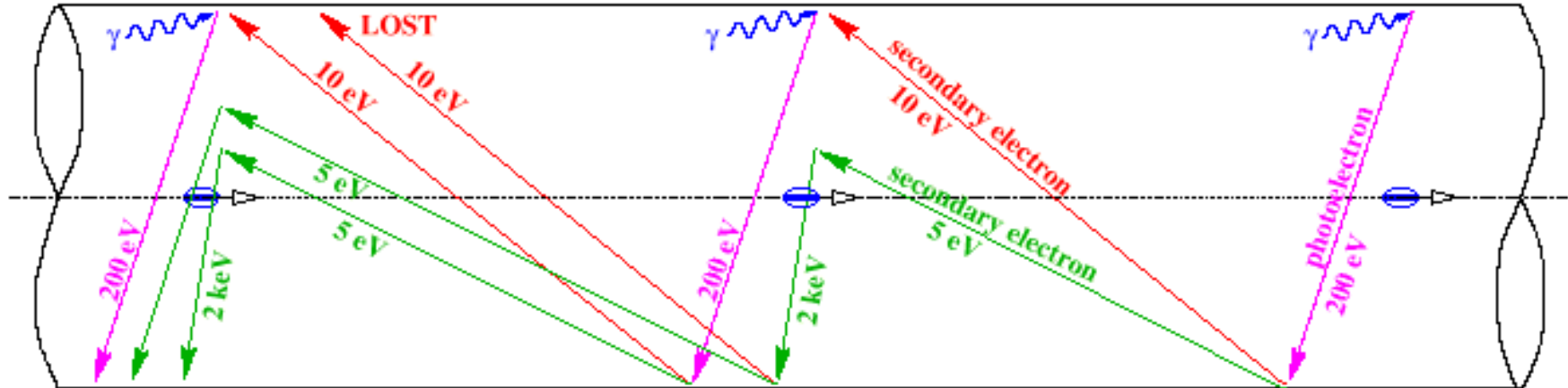

■ Key features of this picture are:

- ❑ Synchrotron photons striking the chamber walls produce primary photoelectrons
- ❑ The photoelectrons can strike the vacuum chamber wall and produce secondary electrons which typically have energies of a few eV
- ❑ When a cloud electron passes near a bunch, it receives a kick and can be accelerated to much higher energies before striking the wall
- ❑ Rapid multiplication of the number of electrons in the chamber along a bunch train can lead to cloud densities of sufficient magnitude to cause beam instabilities and emittance growth



Secondary electron emission



- The main reason why electrons can build up to very high densities around positively charged bunched beams is that, when electrons hit the pipe wall, they do not just disappear.....
 - High energy electrons easily survive and actually multiply through secondary electron emission
 - Low energy electrons tend to survive long because of the high probability with which they are elastically reflected.
- Secondary electron emission is governed by the typical curve below

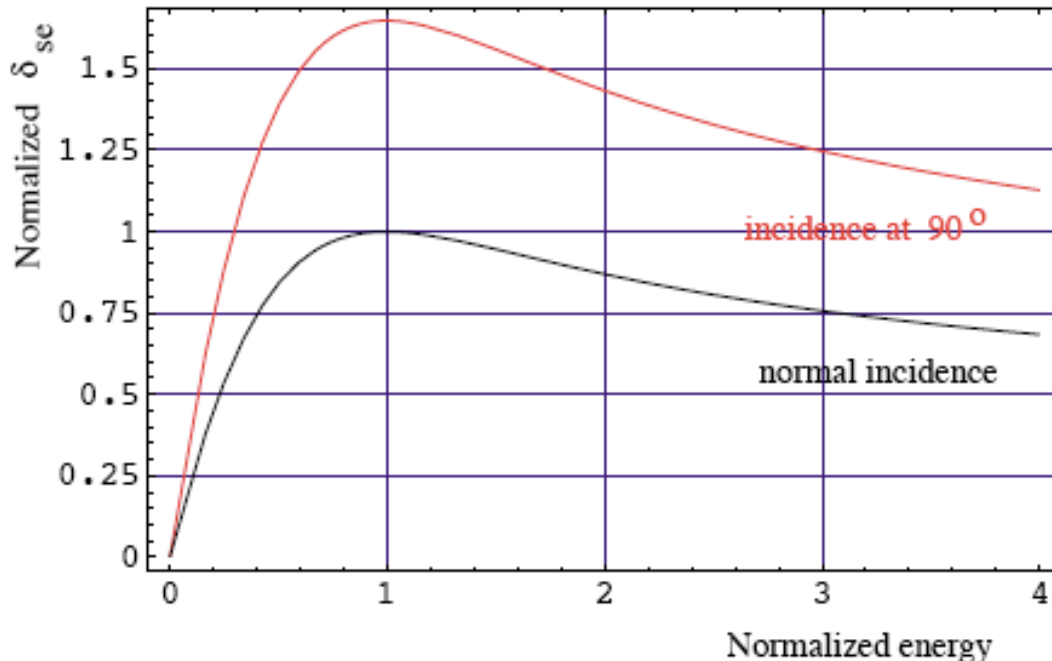

$$\delta_{se}(E_p, \theta) = \delta_{\max} 1.11 x^{-0.35} [1 - \exp(-2.3x^{1.35})] \times \exp\left(\frac{1 - \cos\theta}{2}\right).$$

$$x = E_p / \epsilon_{\max}$$

Secondary electrons have very low energies (<10 eV) and an angular distribution like $(\cos\theta)$

The big problems arise when $d_{\max} > 1$, which means that from only 1 electron more electrons are created.....



Beam Scrubbing



- The SEY can be lowered by electron bombardment (scrubbing effect, efficiency depends on the deposited dose) or by radiation bombardment (conditioning effect). Also the PEY decreases by radiation.
- It is known, for instance, that Stainless Steel has a SEY that decreases from above 2 to ~ 1.6 after relatively high electron bombardment. Other materials, like the TiN, rely on conditioning to get very low maximum SEY (even below 1)

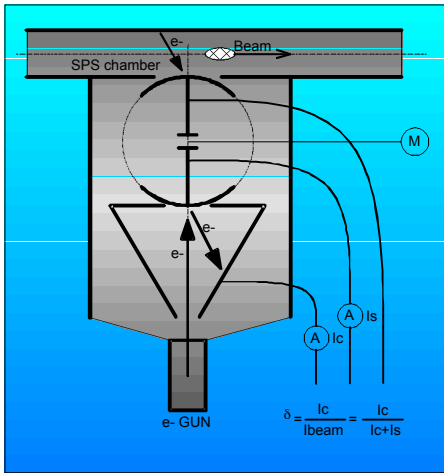

Schematic view of the in-situ SEY detector installed in the SPS

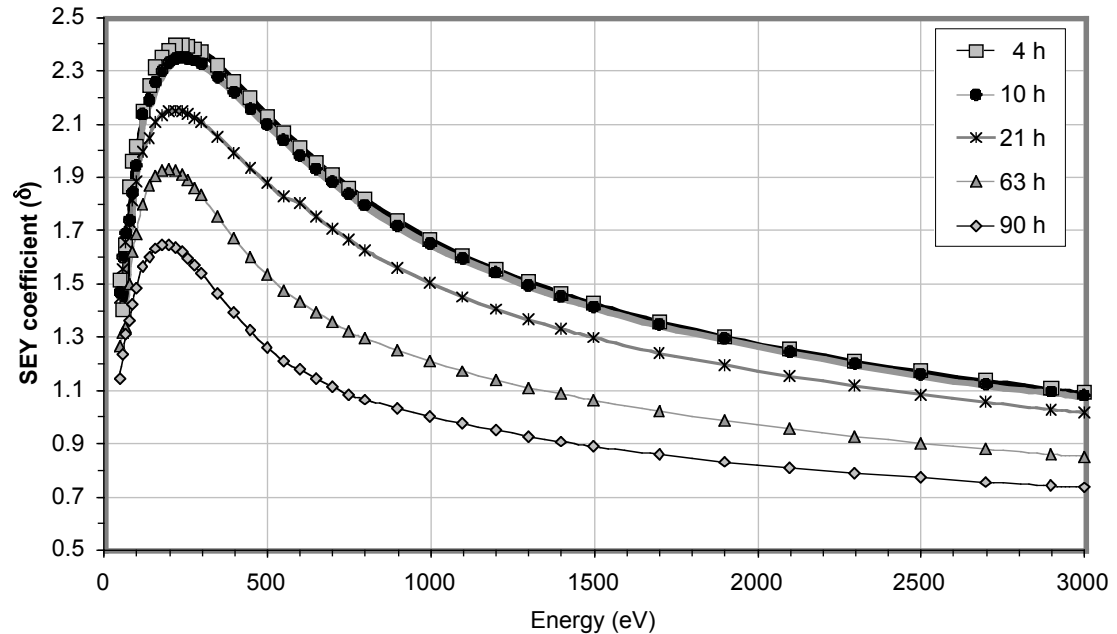



Central densities for different PEYs and SEYs

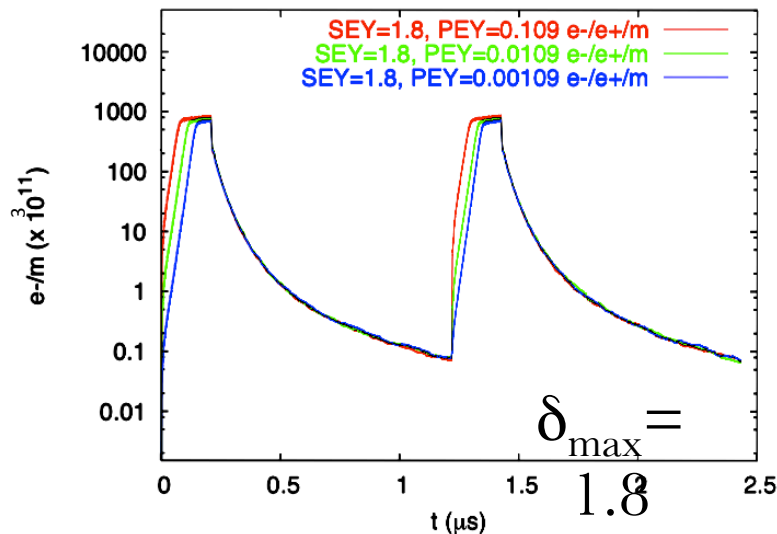
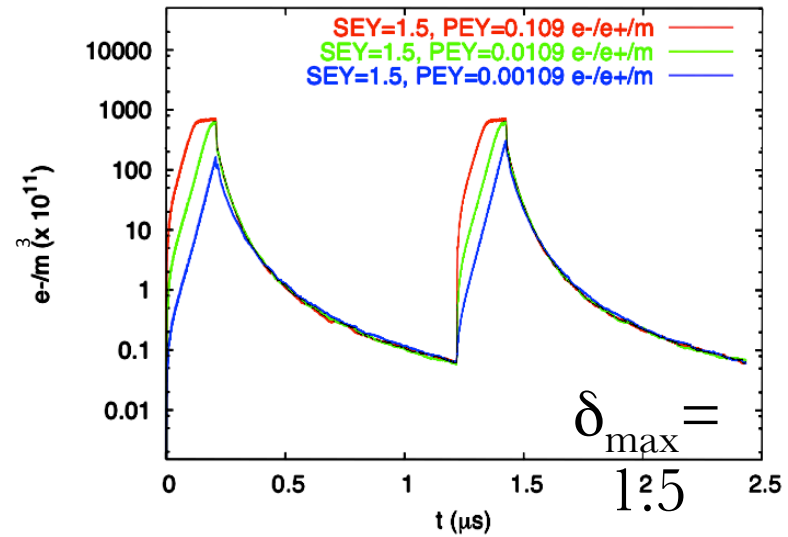
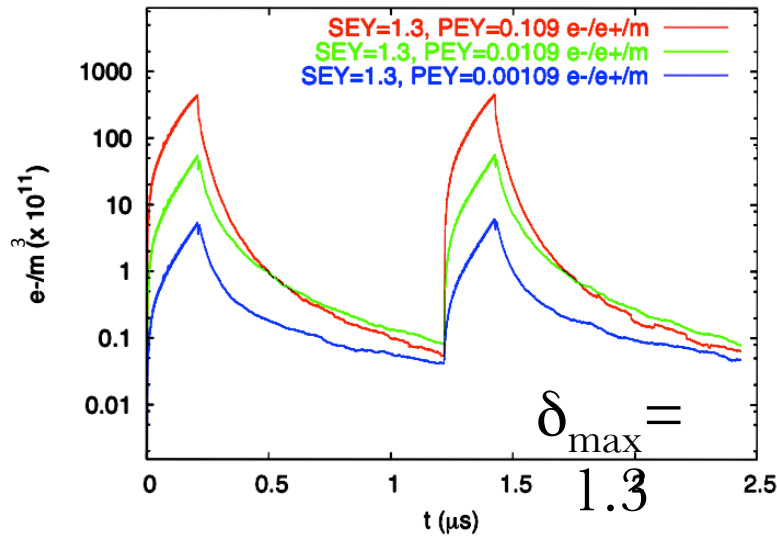

→ To **prevent the electron cloud in the wigglers** from reaching saturation density values causing beam instability (HEADTAIL simulations):

- ✓ **Low PEY** (i.e., 0.01% of the produced radiation not absorbed by an antechamber or by special absorbers or η_{PE} lowered to relax this constraint), though SEY is low
- ✓ **SEY below 1.3**, independently of the PEY



E-cloud heat load in wigglers



Heat load (mW/m)

Damping rings, Linear Collider School 2013

Electron ring

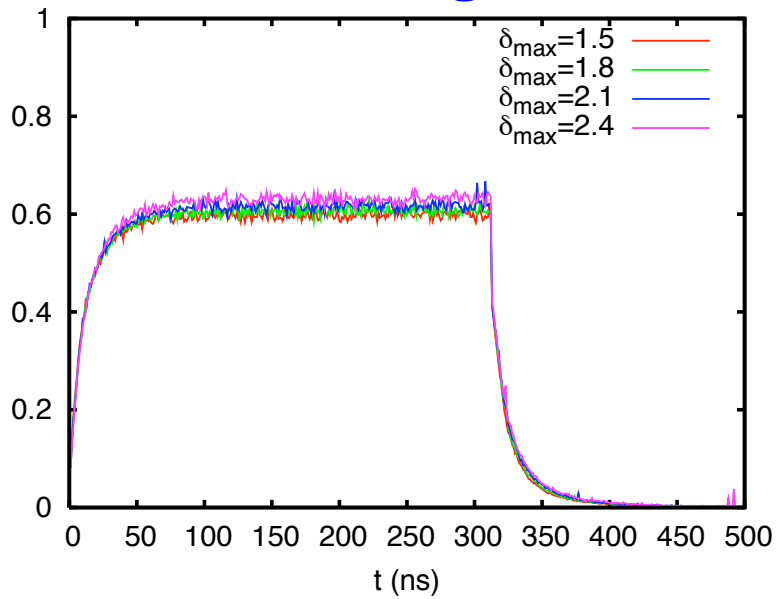

Positron ring

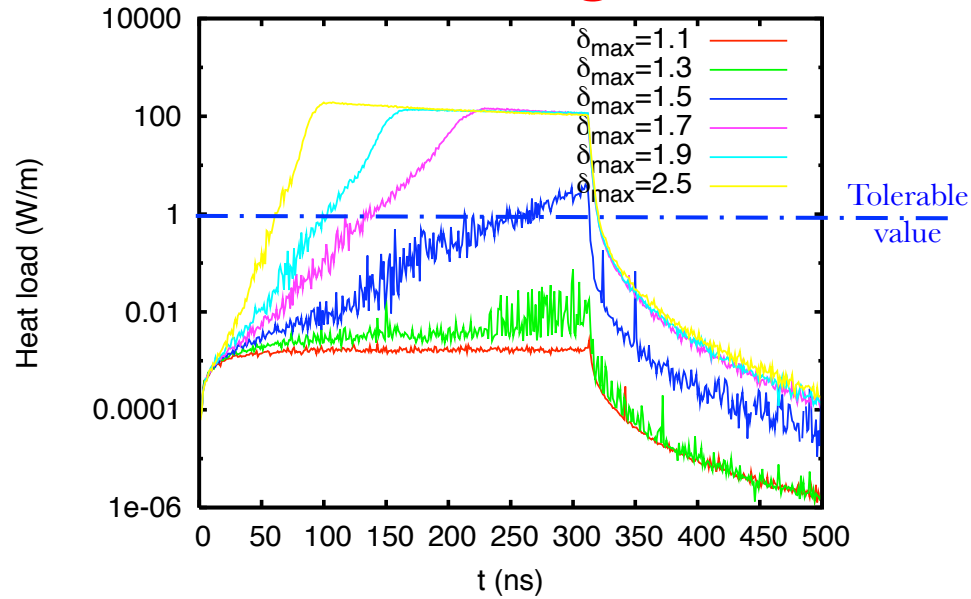

- No significant multipacting (heat load) for the **electron ring** (<1 mW/m)
 - Vacuum specification determined by the fast ion instability
- Multipacting appears in the **positron ring** for δ_{max} above 1.3 (but causes strong e-cloud over 1 train passage for values above 1.4-1.5)
 - For values of δ_{max} above 1.4 the heat load grows to values above 1 W/m!
 - Anyway, electron clouds with these values make the beam unstable...
 - With 1GHz, δ_{max} below 1.3 and 0.1% of residual radiation seem acceptable!
 - Low SEY coating (a-C, NEG) is needed



E-cloud mitigation



Clearing electrodes installed along the vacuum chambers (only local)

Solenoids (only applicable in field-free regions)

Live with e-cloud but damp the instability: feedback system

Possible Solutions

To find out other thin films with an intrinsically low SEY.

To render the surface rough enough to block secondary electrons.

... or both combined

Lower activation temperature NEG

No need of heating once in vacuum

By machining

By coating

By chemical or electrochemical methods

Linear Collider School 2012
Dampf



Electron cloud mitigation with Solenoids

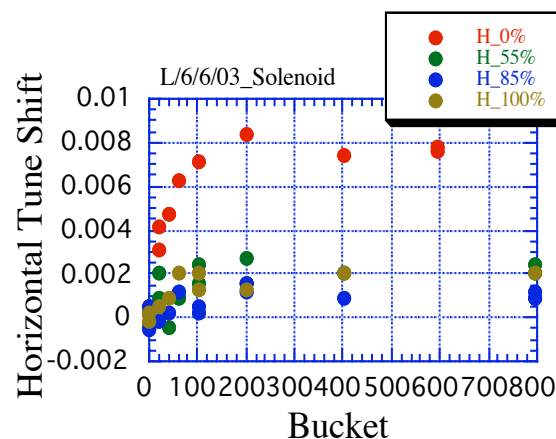
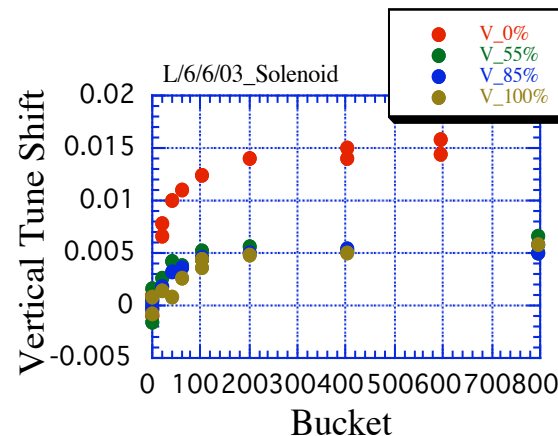
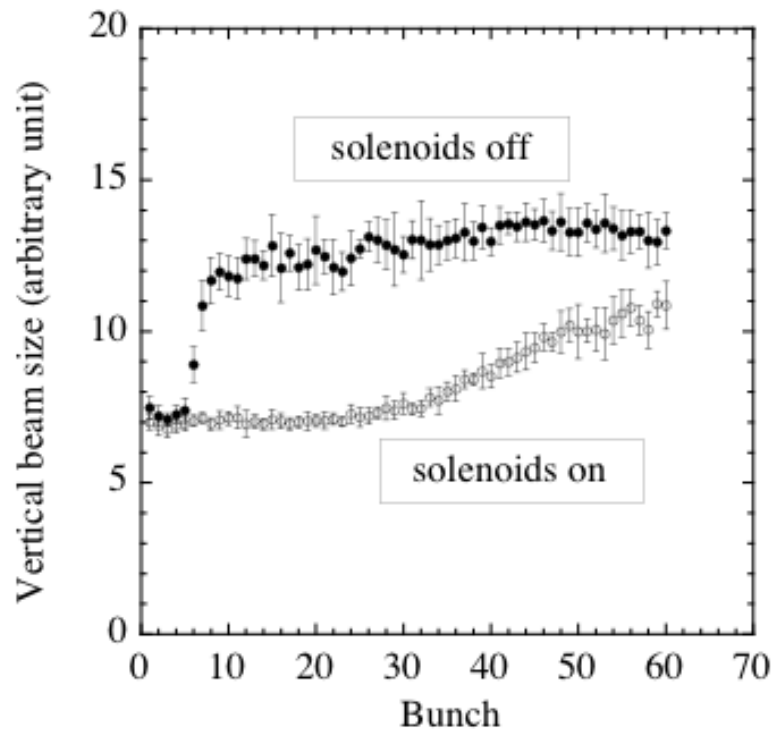

- Solenoids have been successfully used at the LER of KEKB
- Switching them on drastically reduces the beam size blow up as well as the tune shift along the batch



■ One method is to coat the surface of vacuum chambers with low SEY materials. TiN is an excellent candidate and shows SEY peak values that drop below unity after suitable processing. NEG coatings are also promising.

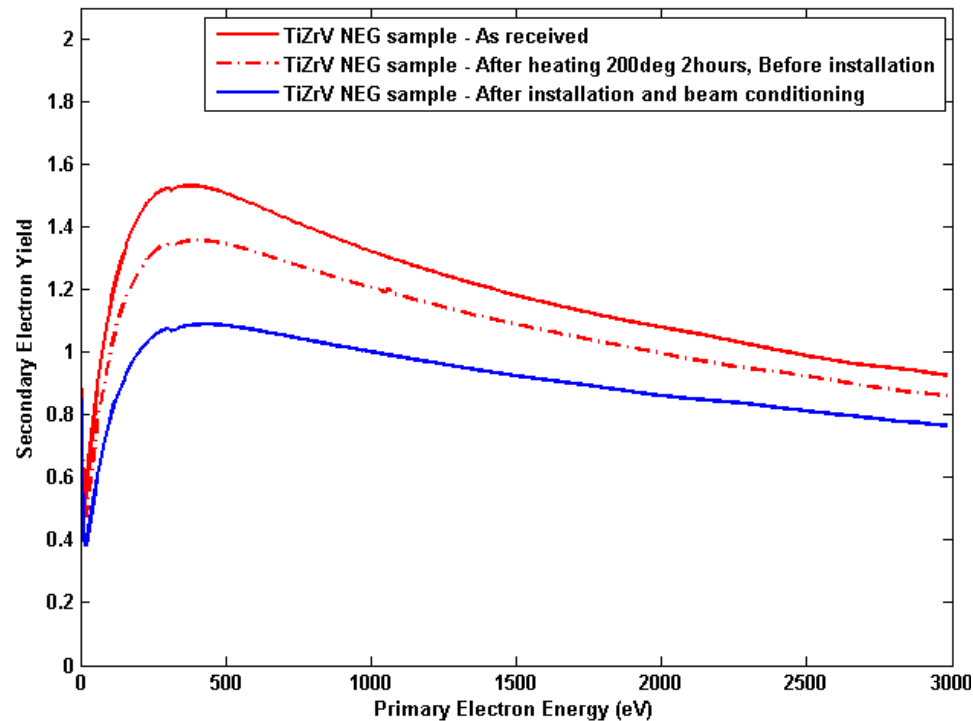
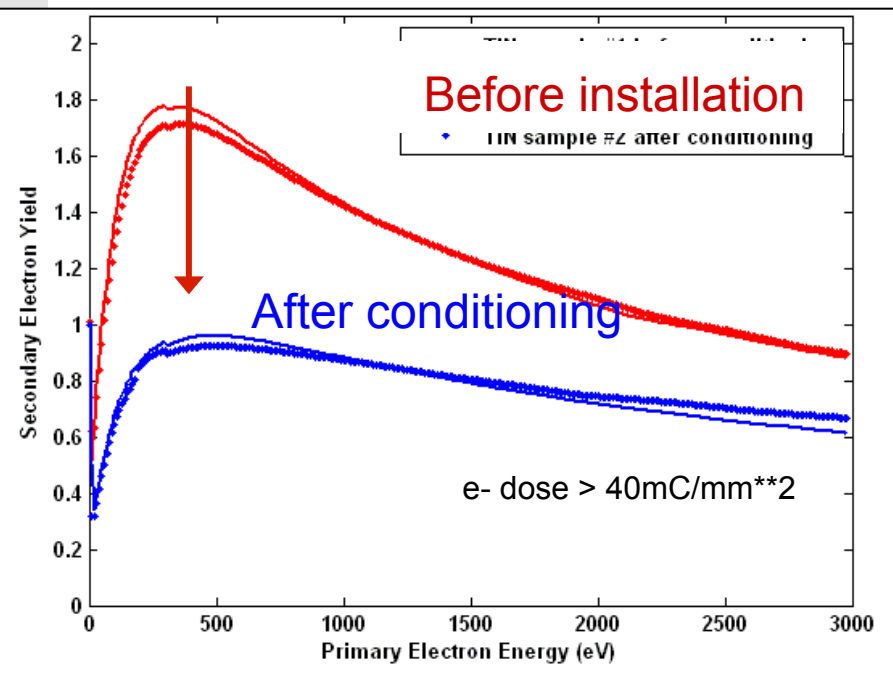

ILC tests, M. Pivi et al. – SLAC

PEY of an a-C coated surface



- Run with positrons at 5 GeV, example of intensity scan at Cesr-TA
- Comparing data with two bunch spacings and train lengths (45 x 14ns, 75 x 28ns). The total electron current is displayed as a function of the beam current.

e+ 5GeV Soln Off 1x45 14ns vs. 1x75 28ns

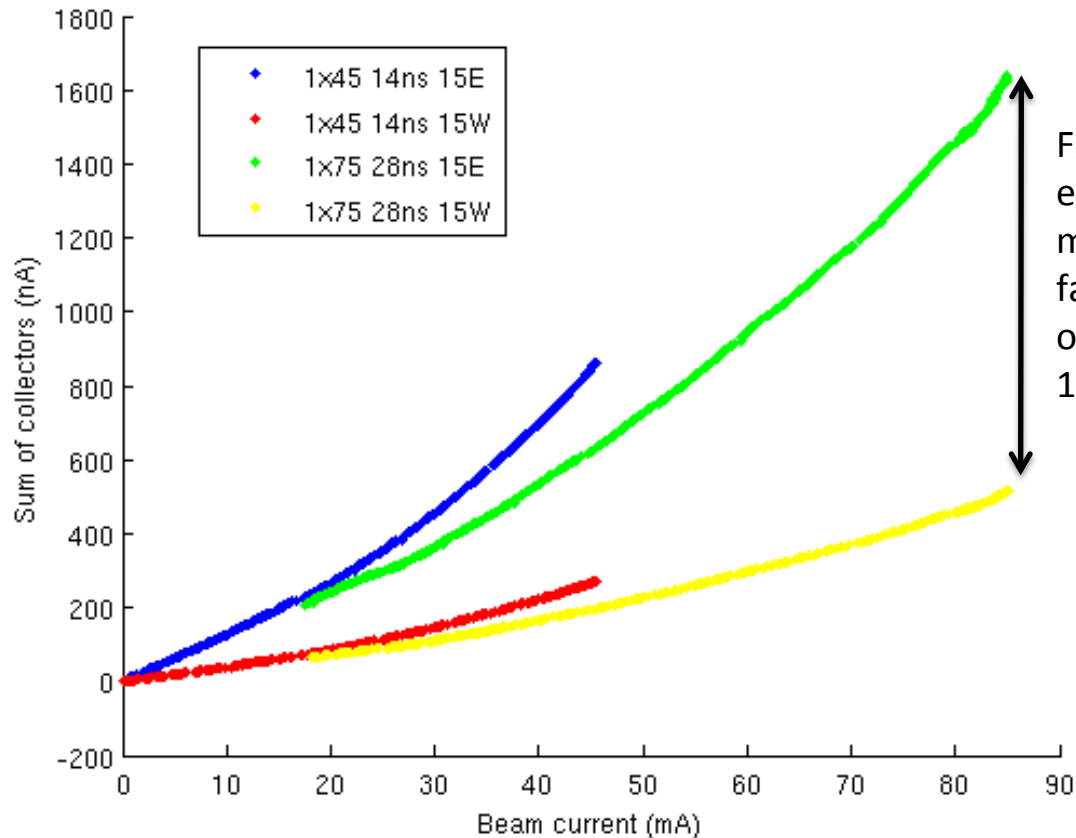

15W is a C-coated chamber

15E is an Al chamber

Factor 4 less electron flux, to be multiplied by a factor 2 difference of photoelectron in 15W wrt 15E

- Electrons entering the grooves release secondaries which are reabsorbed at low energy (and hence without releasing further secondaries) before they can be accelerated in the vicinity of the beam.

$B_y=0$

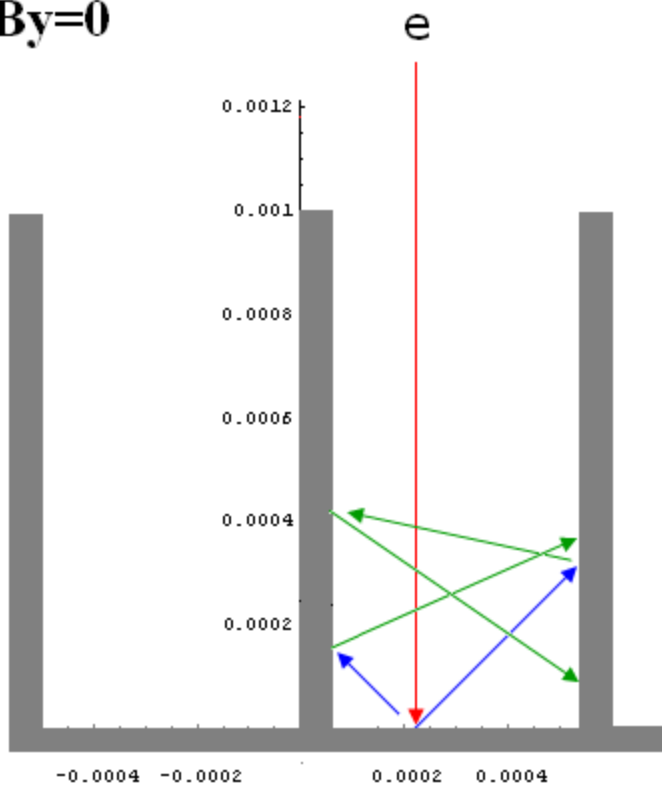

$B_y=0.19T$

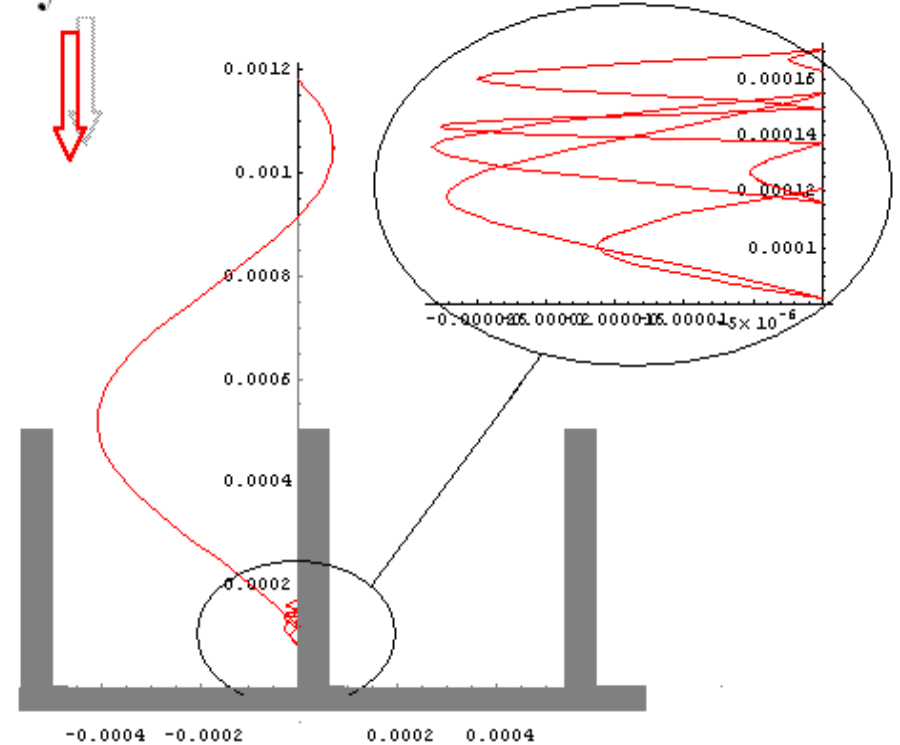

- Measurements suggest that grooves can be very effective at suppressing secondary emission, and will be tested experimentally in PEP-II later this year. Wakefields are a concern, but if the grooves are cut longitudinally, should be ok.

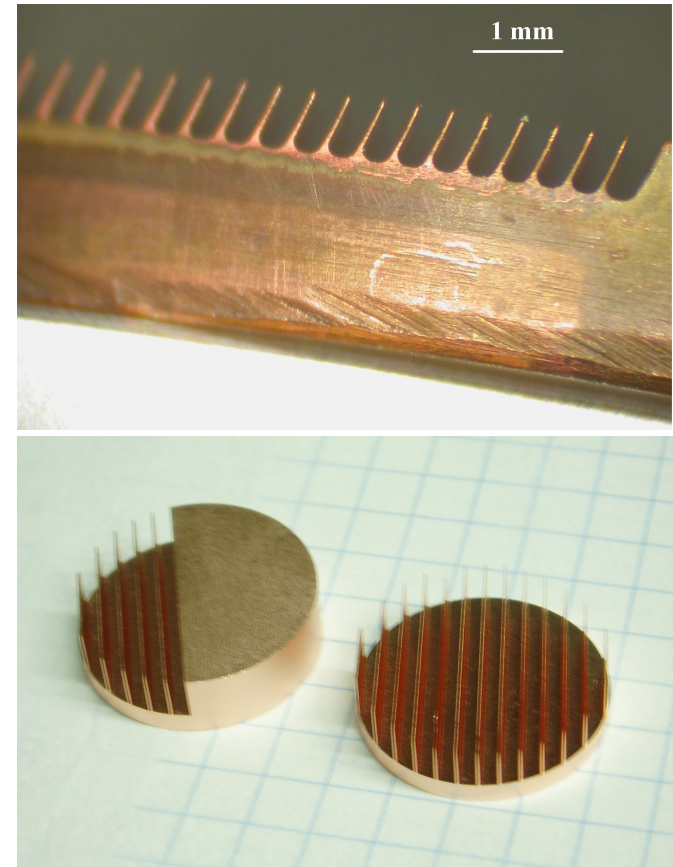
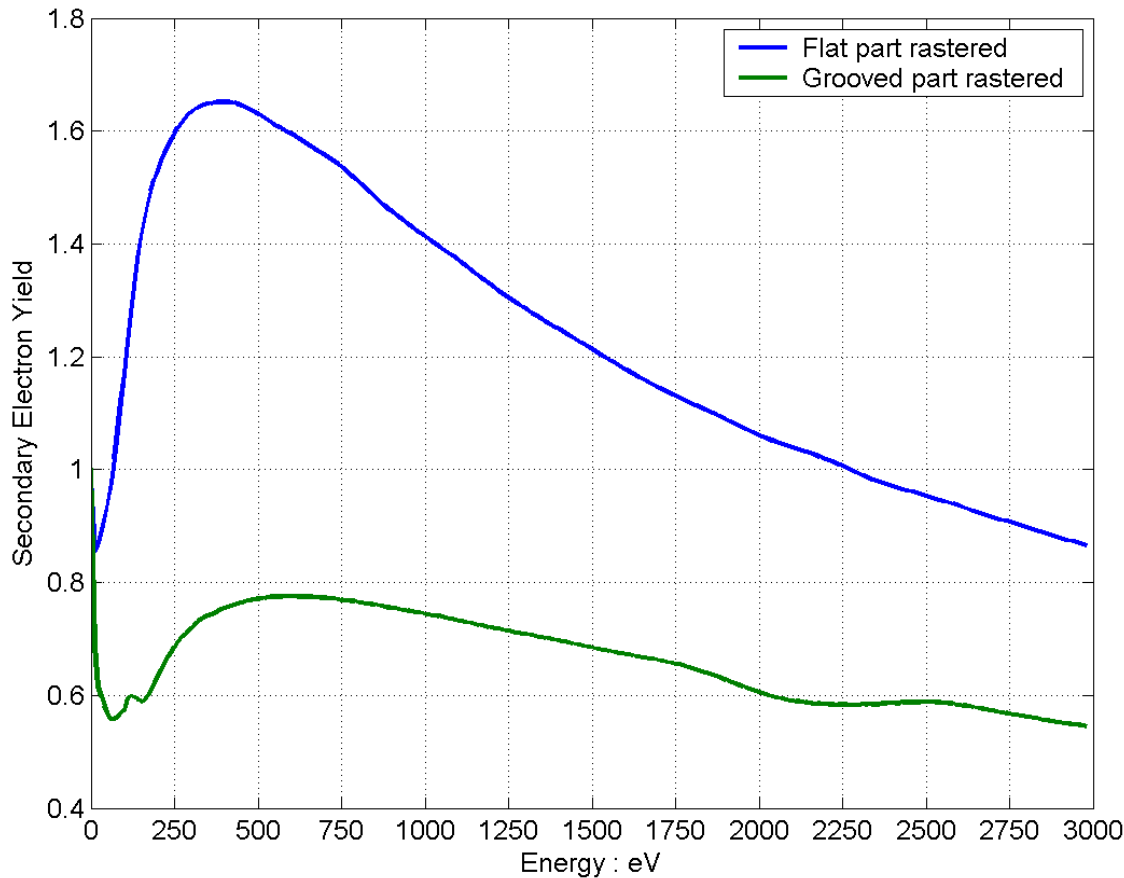

■ *M. Pivi and G. Stupakov*



- Low-energy secondary electrons emitted from the electrode surface are prevented from reaching the beam by the electric field at the surface of the electrode. This also appears to be an effective technique for suppressing build-up of electron cloud.

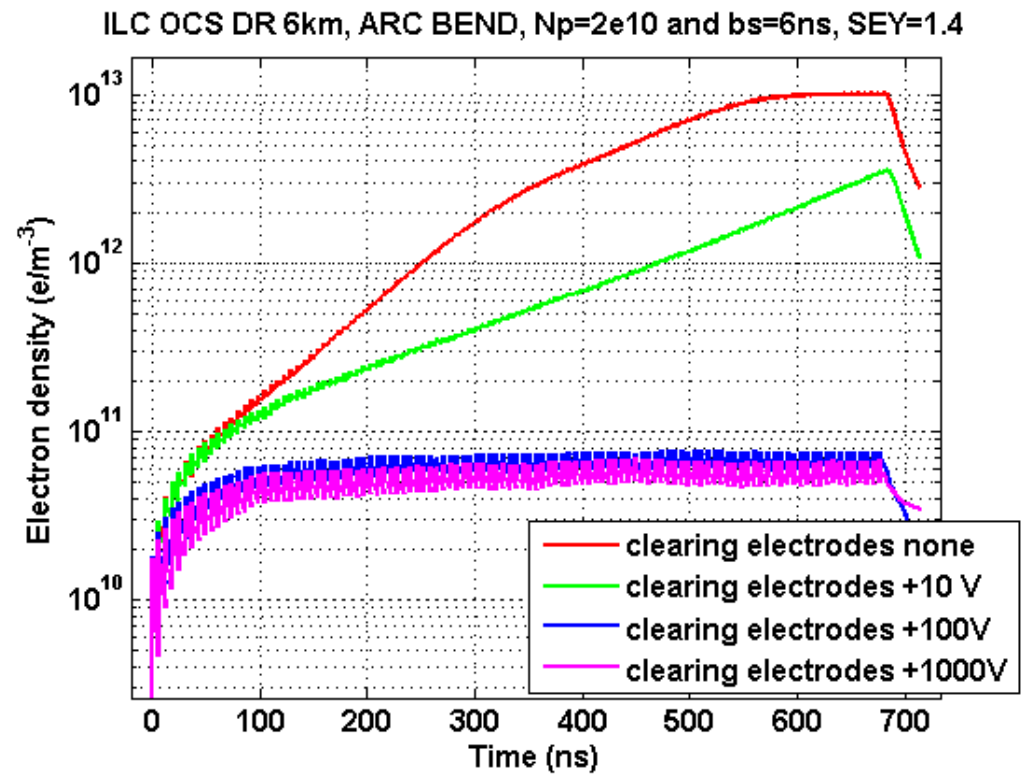
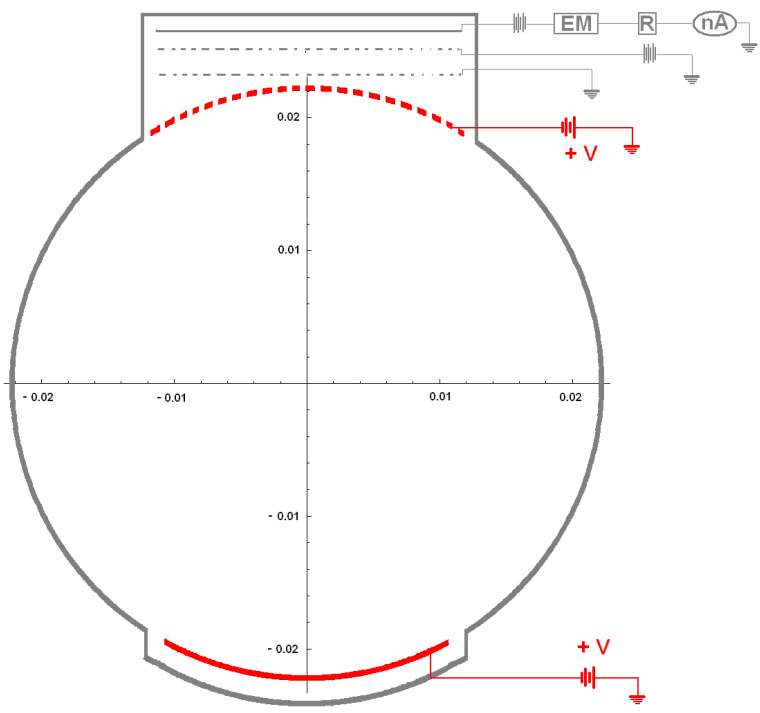



- Collective effect including self-fields, instabilities and two stream effects play a central role in the beam dynamics of the damping rings
- The optimization of all parameters including the lattice design taken into account the full spectrum of collective effects is very important
- A number of them have a large impact in the design and performance of vacuum systems but also of hardware such as kickers, RF, instrumentation and feedback systems.

$$\frac{1}{T_i} = 4\pi A (\log) \left\langle \int_0^\infty \frac{\delta\lambda \lambda^{1/2}}{|L + \lambda I|^{1/2}} \left\{ \text{Tr} L^{(i)} \text{Tr} \left(\frac{1}{L + \lambda I} \right) - 3 \text{Tr} L^{(i)} \left(\frac{1}{L + \lambda I} \right) \right\} \right\rangle$$

$$L^{(p)} = \frac{\gamma^2}{\sigma_p^2} \begin{pmatrix} 0 & 0 & 0 \\ 0 & 1 & 0 \\ 0 & 0 & 0 \end{pmatrix}$$

$$L^{(x)} = \frac{\beta_x}{\epsilon_x} \begin{pmatrix} 1 & -\gamma\phi_x & 0 \\ -\gamma\phi_x & \gamma^2 H_x / \beta_x & 0 \\ 0 & 0 & 0 \end{pmatrix}$$

$$L^{(y)} = \frac{\beta_y}{\epsilon_y} \begin{pmatrix} 0 & 0 & 0 \\ 0 & \gamma^2 H_y / \beta_y & -\gamma\phi_y \\ 0 & -\gamma\phi_y & 1 \end{pmatrix}$$

$$L = L^{(p)} + L^{(x)} + L^{(y)}$$

$$A = \frac{r_0^2 c N}{64\pi^2 \bar{\beta}^3 \gamma^4 \epsilon_x \epsilon_y \sigma_s \sigma_p}$$



$$\frac{1}{T_p} = A \left\langle \frac{\sigma_H^2}{\sigma_p^2} f(a, b, q) \right\rangle$$

$$\frac{1}{T_x} = A \left\langle f\left(\frac{1}{a}, \frac{b}{a}, \frac{q}{a}\right) + \frac{H_x^2 \sigma_H^2}{\epsilon_x} f(a, b, q) \right\rangle$$

$$\frac{1}{T_y} = A \left\langle f\left(\frac{1}{b}, \frac{a}{b}, \frac{q}{b}\right) + \frac{H_y^2 \sigma_H^2}{\epsilon_y} f(a, b, q) \right\rangle$$

$$\frac{1}{\sigma_H^2} = \frac{1}{\sigma_p^2} + \frac{H_x^2}{\epsilon_x} + \frac{H_y^2}{\epsilon_y}$$

$$a = \frac{\sigma_H}{\gamma} \sqrt{\frac{\beta_x}{\epsilon_x}}, \quad b = \frac{\sigma_H}{\gamma} \sqrt{\frac{\beta_y}{\epsilon_y}}, \quad q = \sigma_H \beta \sqrt{\frac{2d}{r_0}}$$

$$f(a, b, q) = 8\pi \int_0^1 du \frac{1-3u^2}{PQ} \left\{ 2 \ln \left[\frac{q}{2} \left(\frac{1}{P} + \frac{1}{Q} \right) \right] - EulerGamma \right\}$$

$$P^2 = a^2 + (1-a^2)u^2, \quad Q^2 = b^2 + (1-b^2)u^2$$

- Bjorken-Mtingwa solution at high energies
- Changing the integration variable of B-M to $\lambda' = \lambda \sigma_H^2 / \gamma^2$

▶ Approximations

- ▶ $a, b \ll 1$ (if the beam cooler longitudinally than transversally) \rightarrow The second term in the braces small compared to the first one and can be dropped
- ▶ Drop-off diagonal terms (let $\xi = 0$) and then all matrices will be diagonal

$$(L + \lambda'I) = \frac{\gamma^2}{\sigma_H^2} \begin{pmatrix} a^2 + \lambda' & -a\xi_x & 0 \\ -a\xi_x & 1 + \lambda' & -b\xi_y \\ 0 & -b\xi_y & b^2 + \lambda' \end{pmatrix}$$

$$\xi_x = \phi_{x,y} \sigma_H \sqrt{\frac{\beta_{x,y}}{\varepsilon_{x,y}}}$$

$$\frac{1}{T_p} \approx \frac{r_0^2 c N(\log)}{16 \gamma^3 \varepsilon_x^{3/4} \varepsilon_y^{3/4} \sigma_s \sigma_p^3} \langle \sigma_H g(a/b) (\beta_x \beta_y)^{-1/4} \rangle$$

$$\frac{1}{T_{x,y}} \approx \frac{\sigma_p^2 \langle H_{x,y} \rangle}{\varepsilon_{x,y}} \frac{1}{T_p}, \quad g(a) = \frac{2\sqrt{a}}{\pi} \int_0^\infty \frac{du}{\sqrt{1+u^2} \sqrt{a^2+u^2}}$$

■ Piwinski formalism at high energies

$$g(\omega) = \sqrt{\pi/\omega} \left[P_{-1/2}^0 \left(\frac{\omega^2 + 1}{2\omega} \right) \pm \frac{3}{2} P_{-1/2}^{-1} \left(\frac{\omega^2 + 1}{2\omega} \right) \right]$$

$$\frac{1}{T_p} \approx 2\pi^{3/2} A(\log) \left\langle \frac{\sigma_H^2}{\sigma_p^2} \left(\frac{g(b/a)}{a} + \frac{g(a/b)}{b} \right) \right\rangle,$$

$$\frac{1}{T_x} \approx 2\pi^{3/2} A(\log) \left\langle -ag\left(\frac{b}{a}\right) + \frac{\mathcal{H}_x \sigma_H^2}{\varepsilon_x} \left(\frac{g(b/a)}{a} + \frac{g(a/b)}{b} \right) \right\rangle$$

$$\frac{1}{T_y} \approx 2\pi^{3/2} A(\log) \left\langle -bg\left(\frac{a}{b}\right) + \frac{\mathcal{H}_y \sigma_H^2}{\varepsilon_y} \left(\frac{g(b/a)}{a} + \frac{g(a/b)}{b} \right) \right\rangle$$