

AHCAL

Mechanics

status report

Karsten Gadow

CALICE Collaboration Meeting

Argonne, 19.03.2014

Outline AHCAL Mechanics

Status Report

1. Mechanics for test beam setups
2. EUDET test beam setup
3. Tungsten test beam setup
4. Cabling and Cooling
5. Absorber Structure validation (earth quake)



1. Mechanics for test beam setups
2. EUDET test beam setup
3. Tungsten test beam setup
4. Cabling and cooling
5. Absorber structure validation (earth quake)



PS user schedule for 2014

schedule issue date: 12-Mar-2014

Version: 0.0

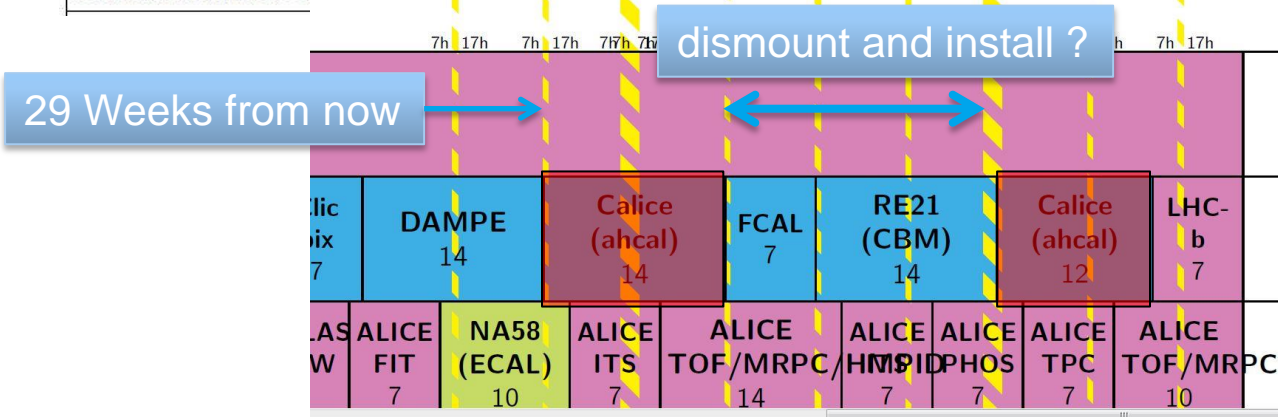
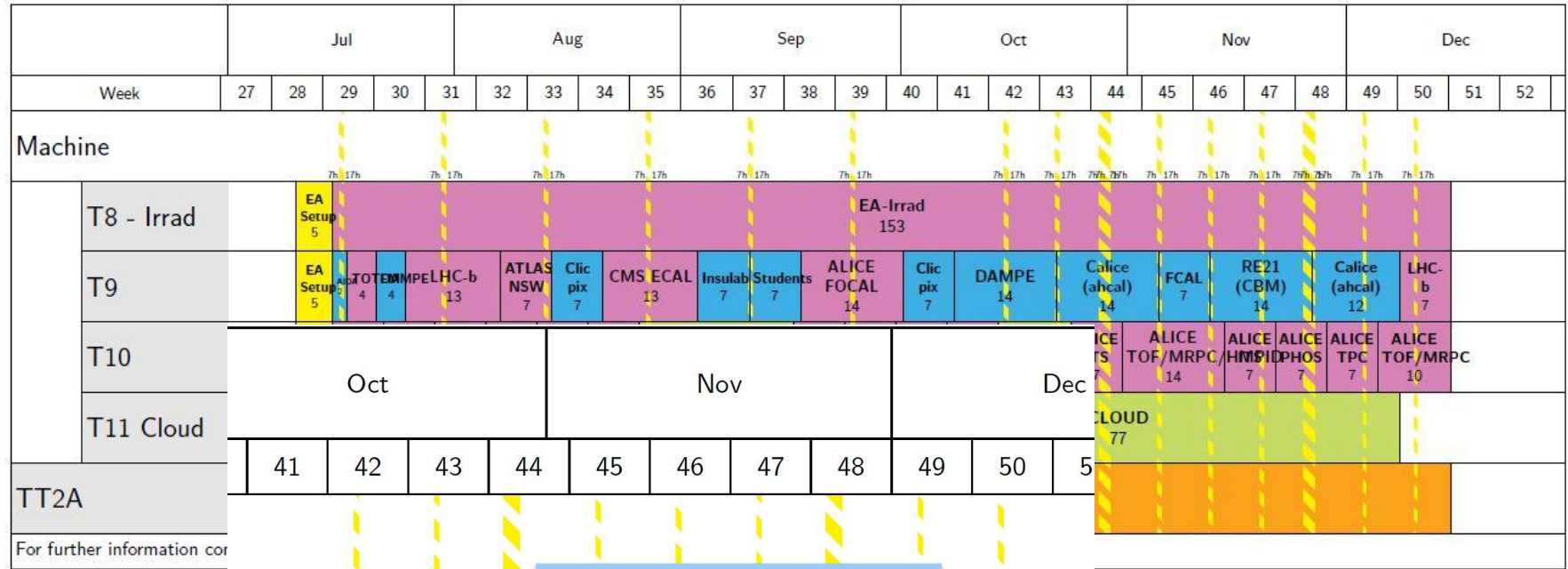

AHCAL Mechanics

Mechanics for test beam setup

T9 floor plan

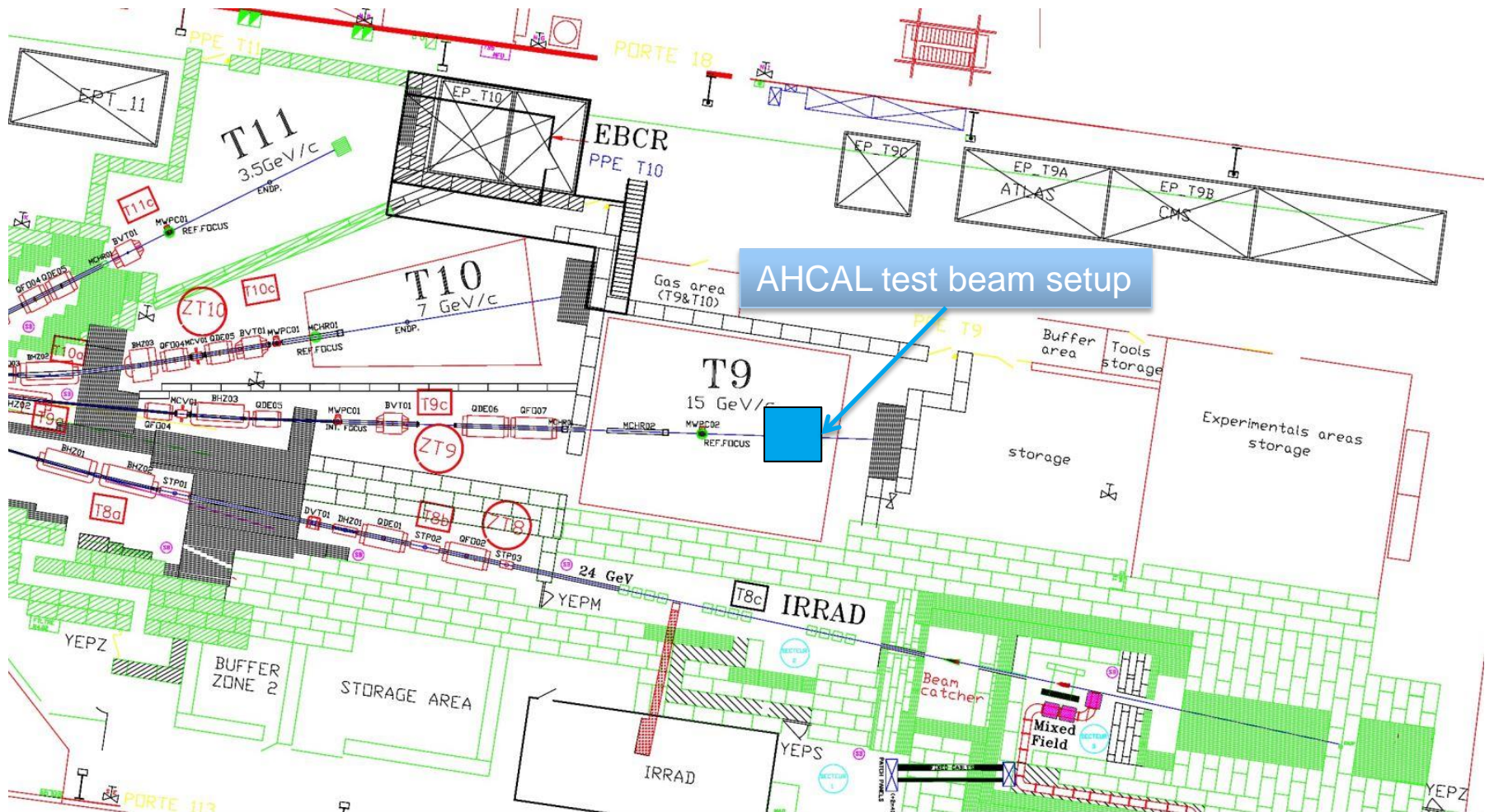

AHCAL Mechanics

Mechanics for test beam setup

Movable Stage with 2 x absorber stack

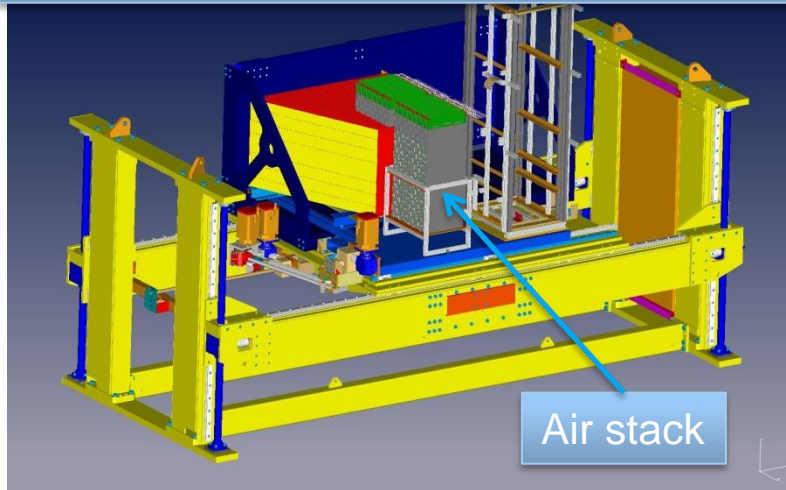

2 x absorber stack stand alone

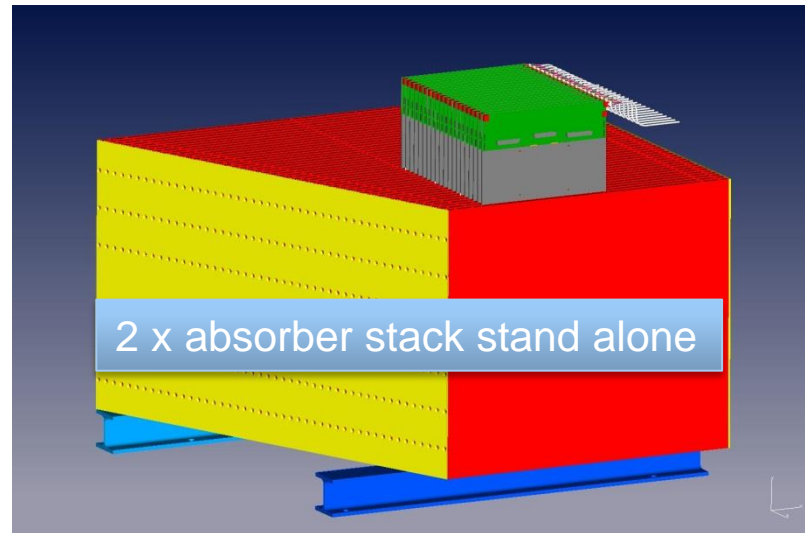

Movable stage with 1 x absorber stack



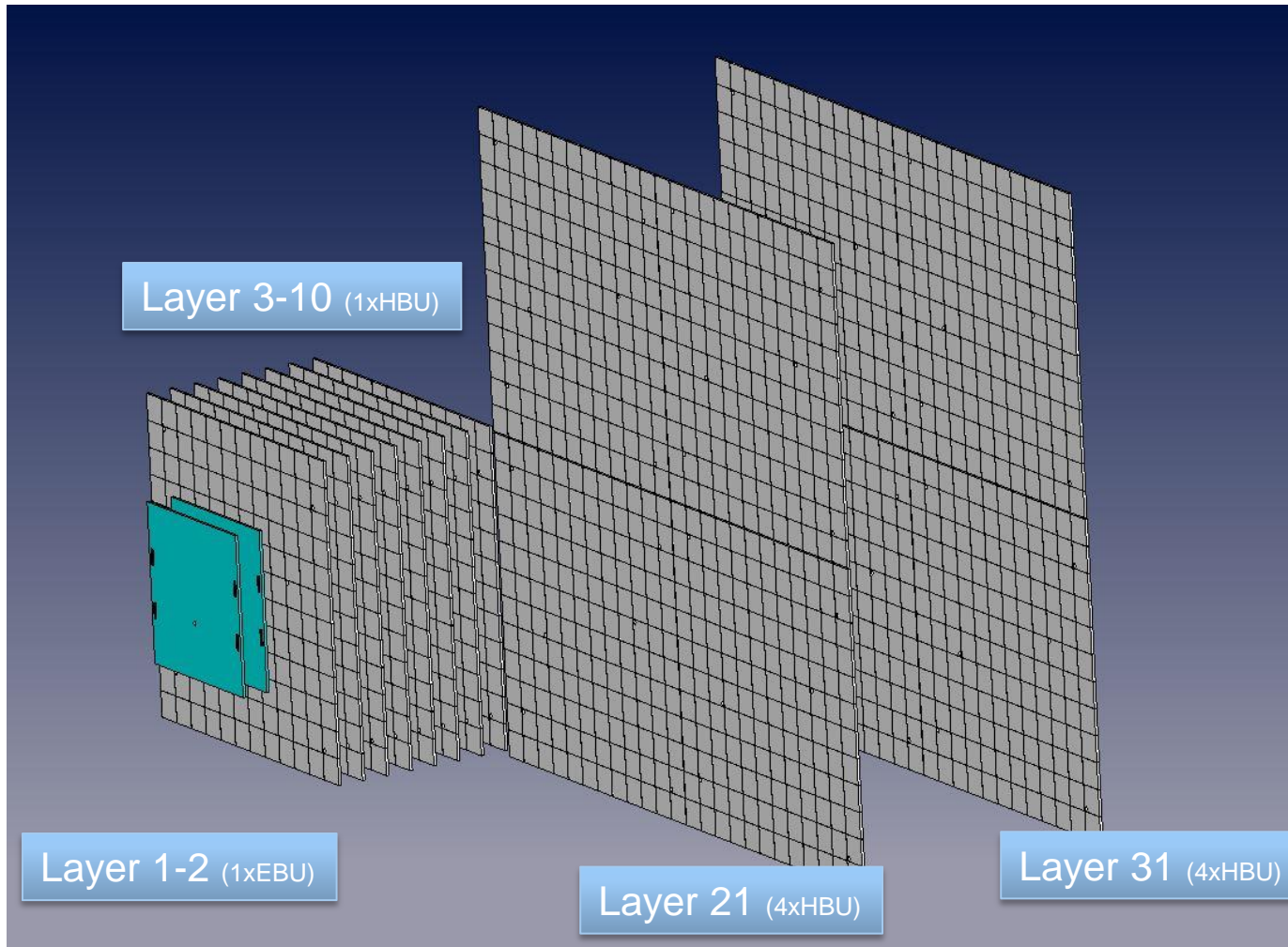

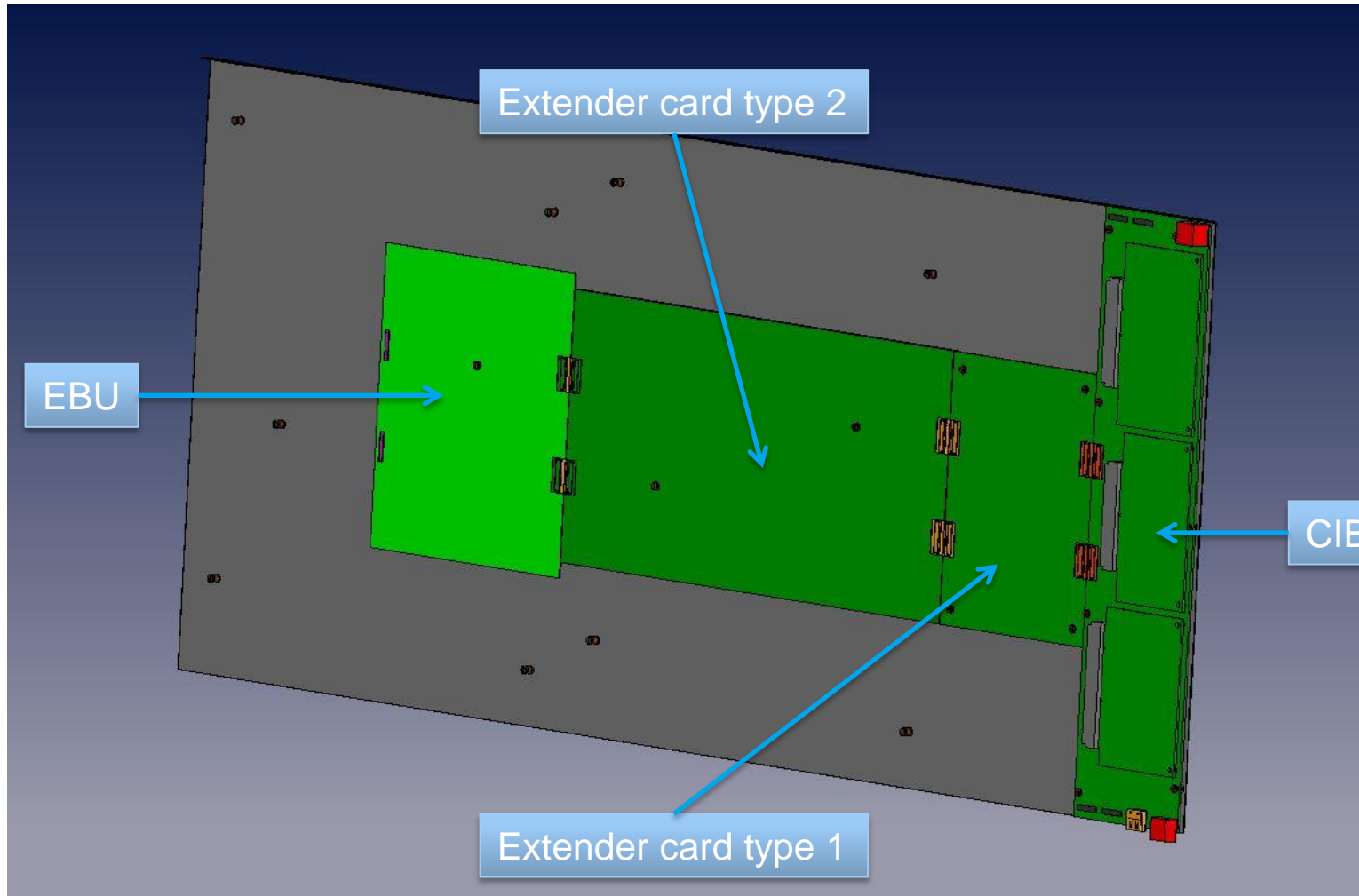

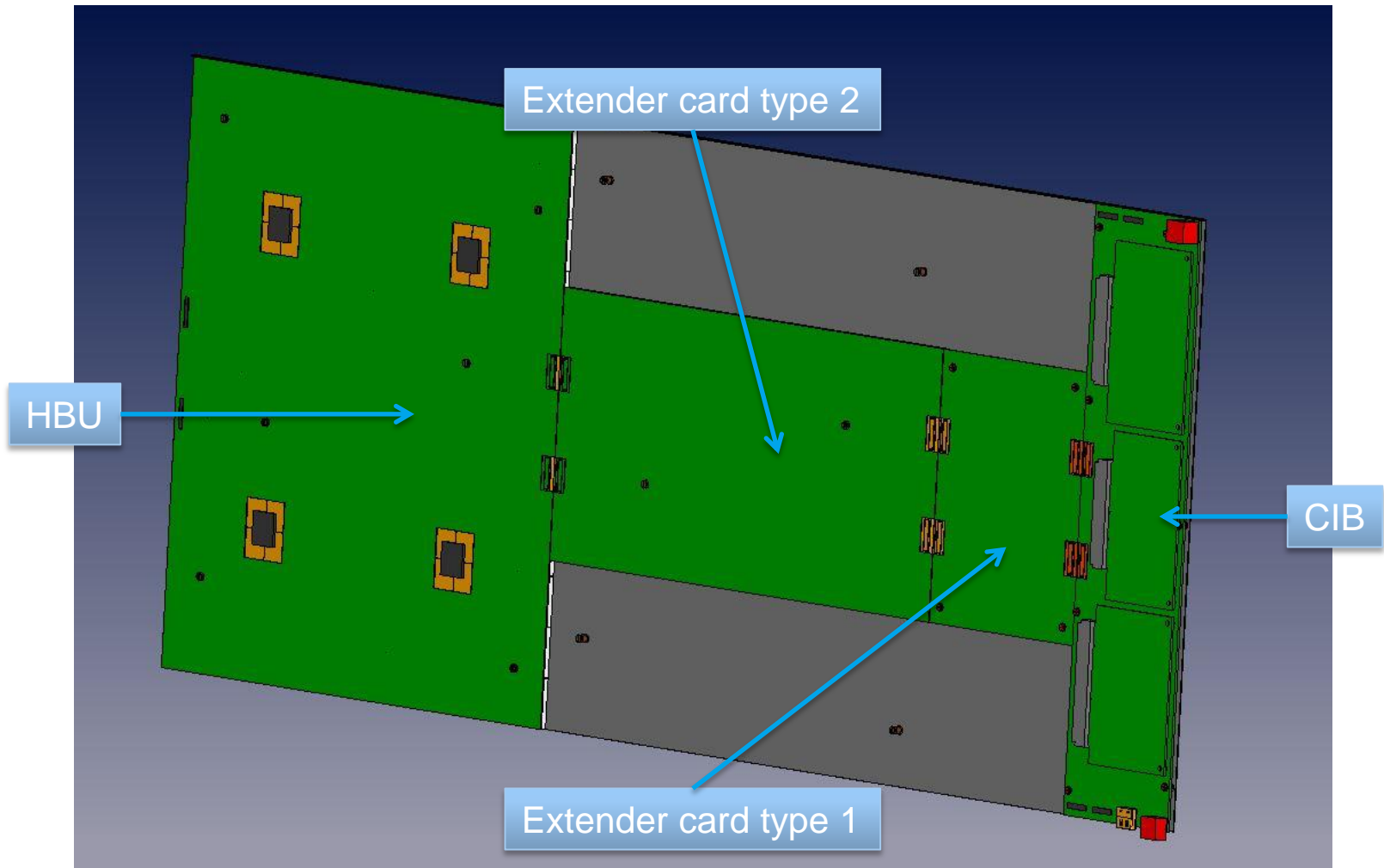

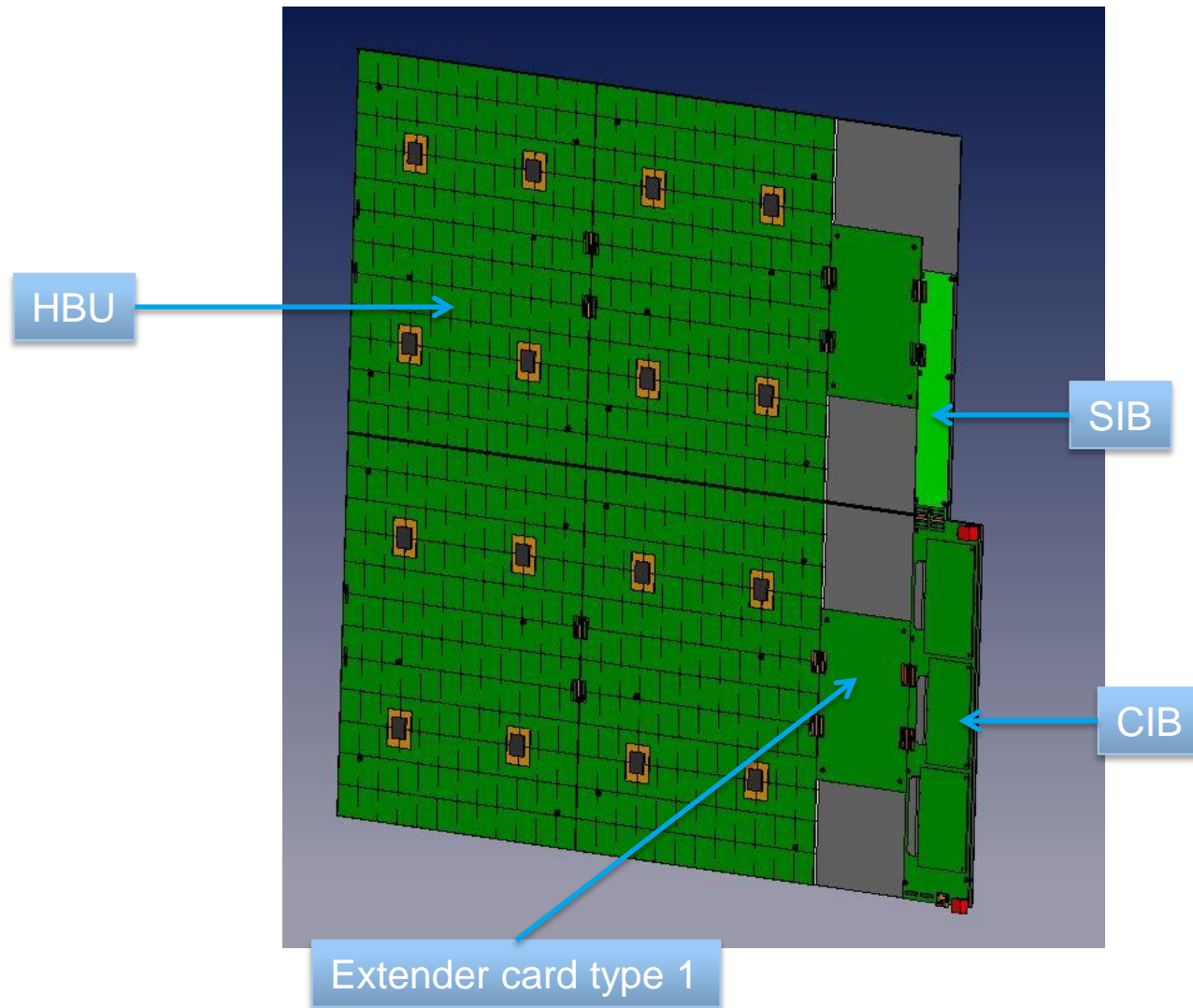

AHCAL Mechanics

Mechanics for test beam setup

Task list (Summary):

- test beam schedule fixed !!!
- Movable Stage not used ! stand by
- EUDET absorber structure ready
- Tungsten absorber structure ready
- air stack needed? ?
- delivery of 50 pc. 2xHBU-extended-CIB housings KW19
- delivery of 50 pc. 2xHBU-extended-SIB housings KW19
- mounting of 14 fully equipped housings to EUDET absorber stack KW28 to KW29
- install supply and read out hardware KW28 to KW29
- commission and test KW30 to KW34
- mounting of 14 fully equipped housings to Tungsten absorber stack frames KW34
- commission and test (in air stack?) KW35 to KW38
- pack test beam setup equipment KW39
- transport from DESY to CERN KW40
- T9 Phase1 KW43 to 45 2014
- position inside the T9 allows parasitic measurements or reinstallation? KW45 to 48 2014
- T9 Phase2 KW48 to 50 2014



1. Mechanics for test beam setups
2. EUDET test beam setup
3. Tungsten test beam setup
4. Cabling and cooling
5. Absorber structure validation (earth quake)



AHCAL Mechanics

EUDET test beam setup

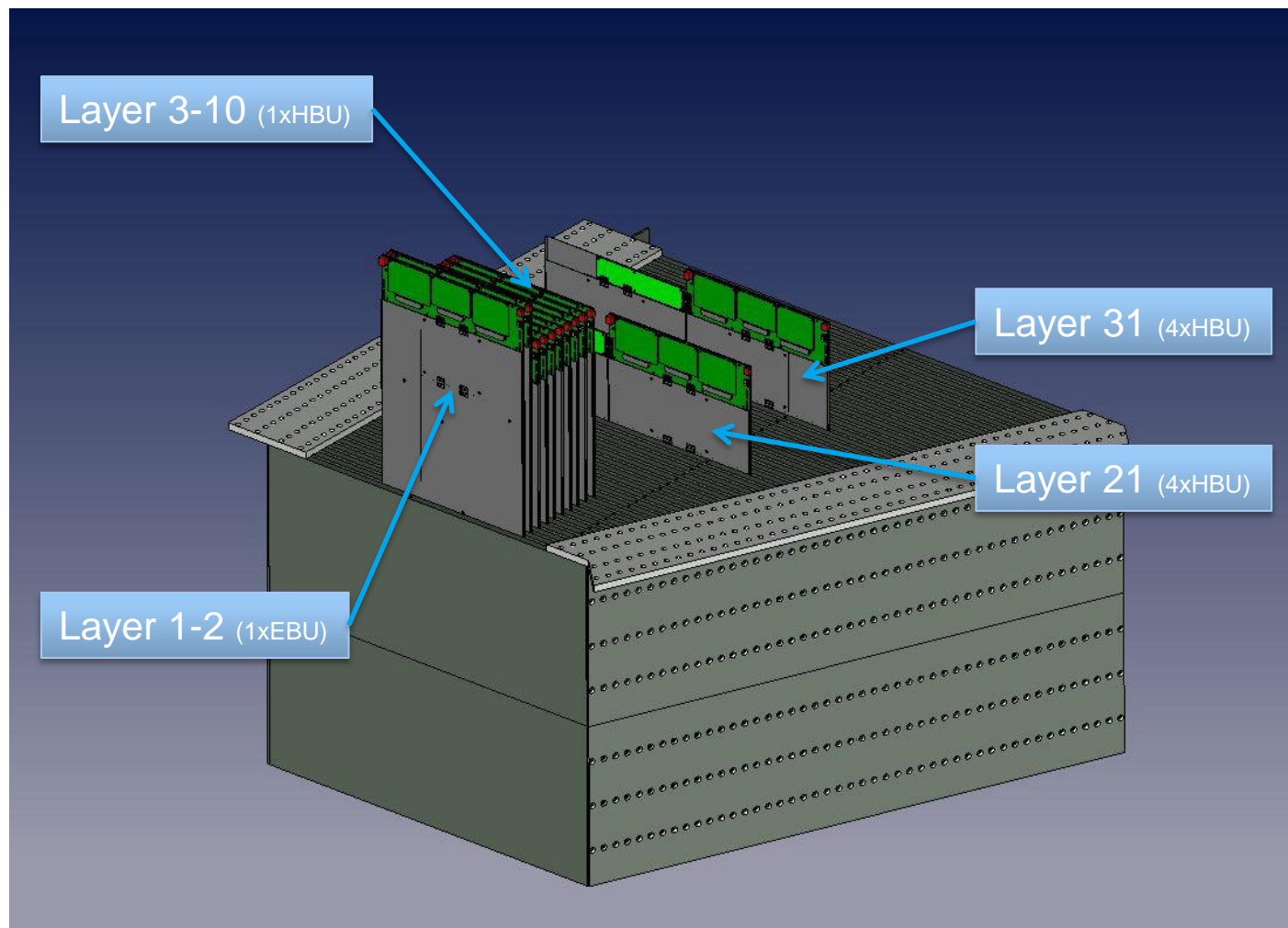

AHCAL Mechanics

EUDET test beam setup

Layer 1 and 2

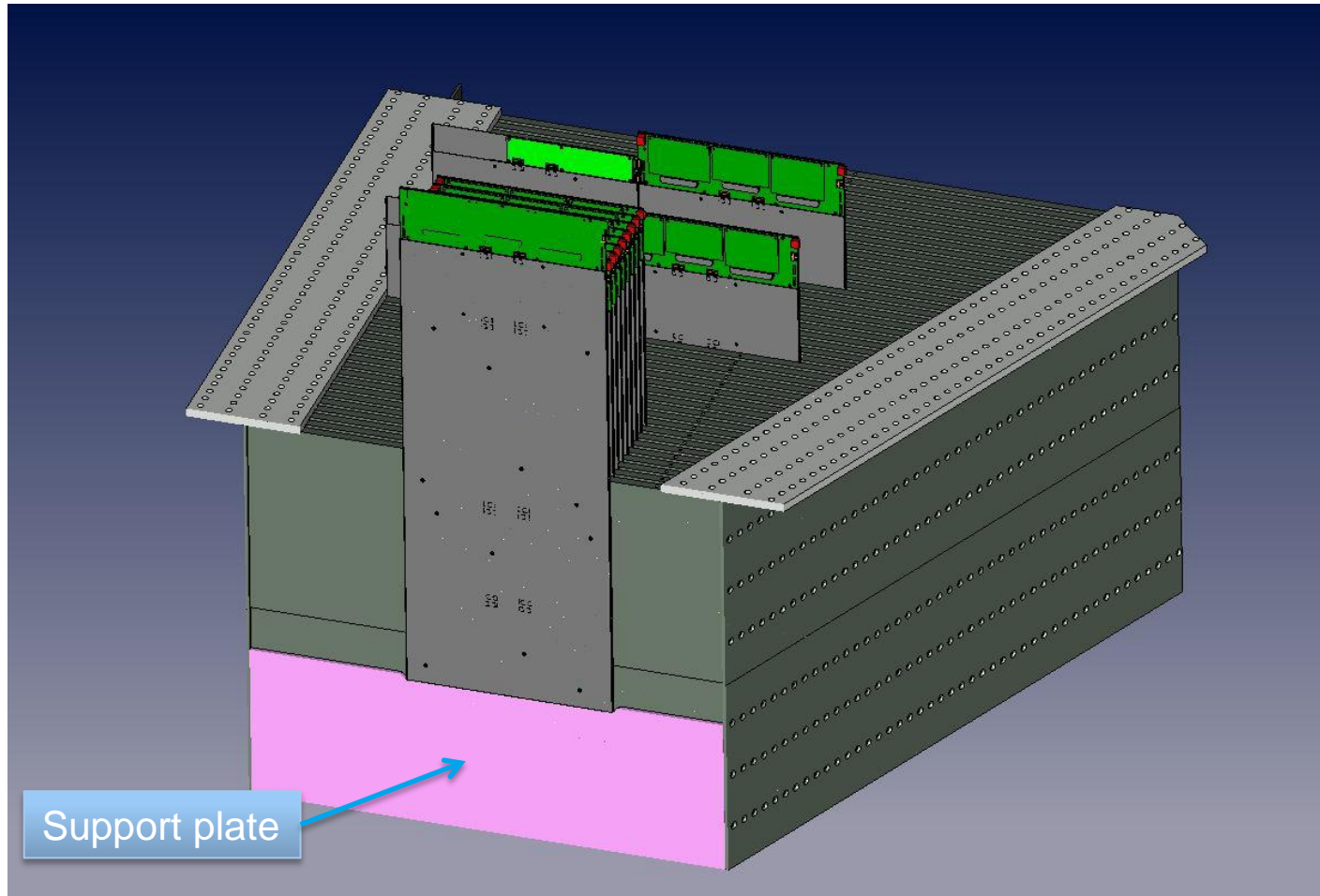

AHCAL Mechanics

EUDET test beam setup

Layer 3 to 10

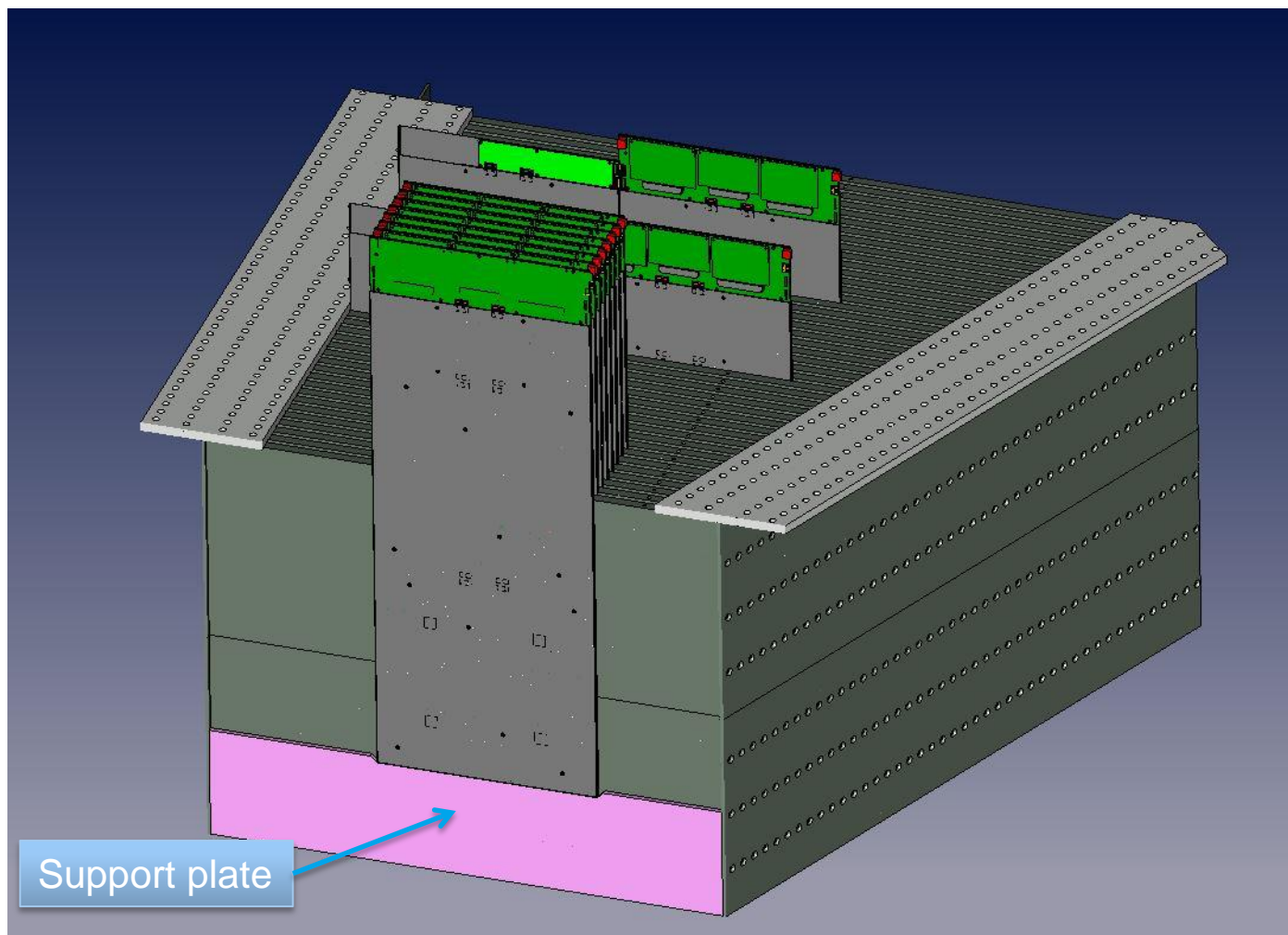

AHCAL Mechanics

EUDET test beam setup Layer 21 and 31

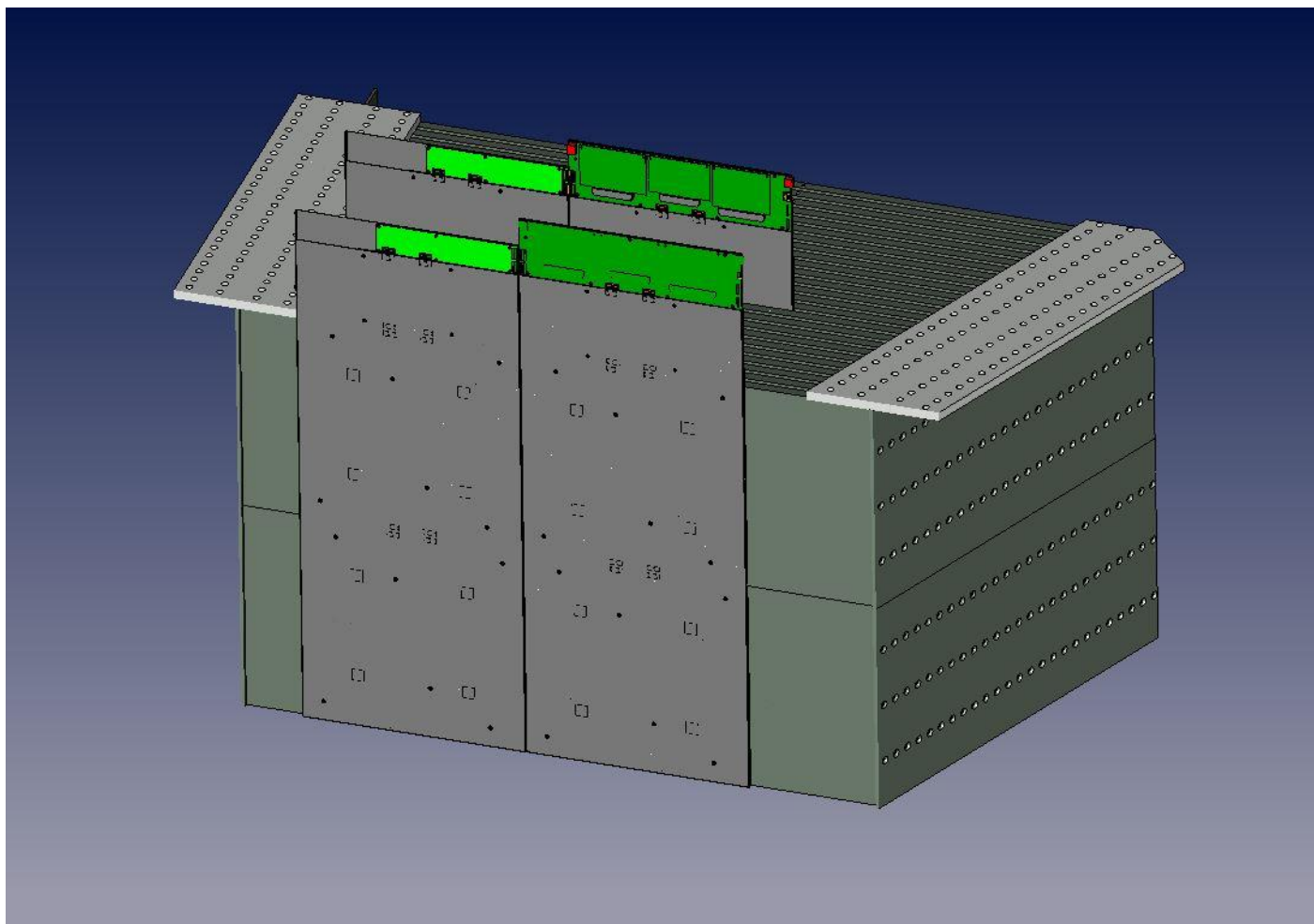

Task list (Summary):

> Test beam setup

- test beam Phase1 or Phase2 ?
- position inside T9 ?
- installation design for self standing absorber structure **done**
- supply, read out and cooling scheme **done**

> Detector layer production

- production of housings **ongoing**
- production of 16 equipped HBU ?
- production of extender cards ?
- production of support plates **ongoing**

Detailed Schedule as to be worked out during this Meeting!

1. Mechanics for test beam setups
2. EUDET test beam setup
3. Tungsten test beam setup
4. Cabling and cooling
5. Absorber structure validation (earth quake)



AHCAL Mechanics

Tungsten test beam setup

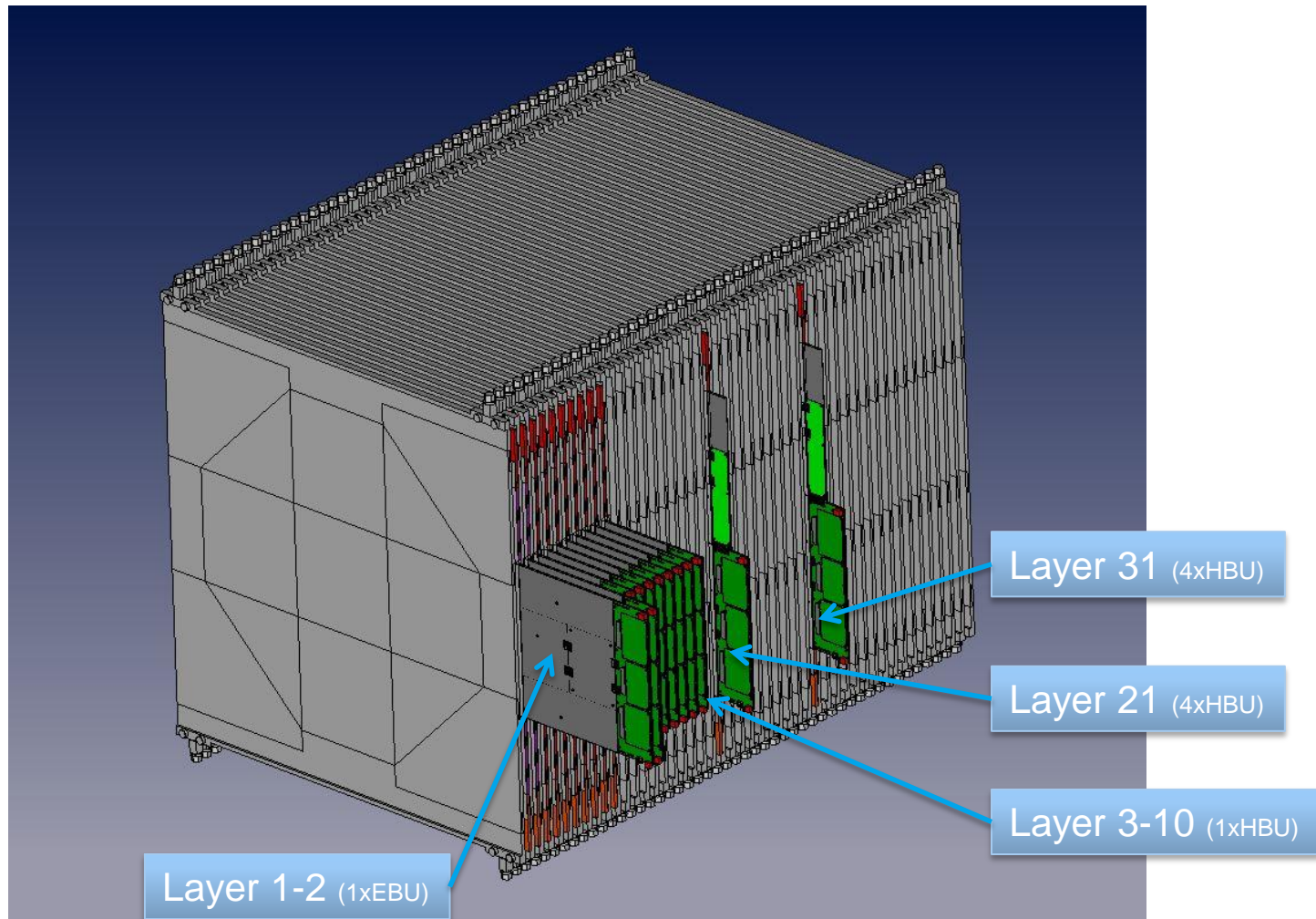

AHCAL Mechanics

Tungsten test beam setup

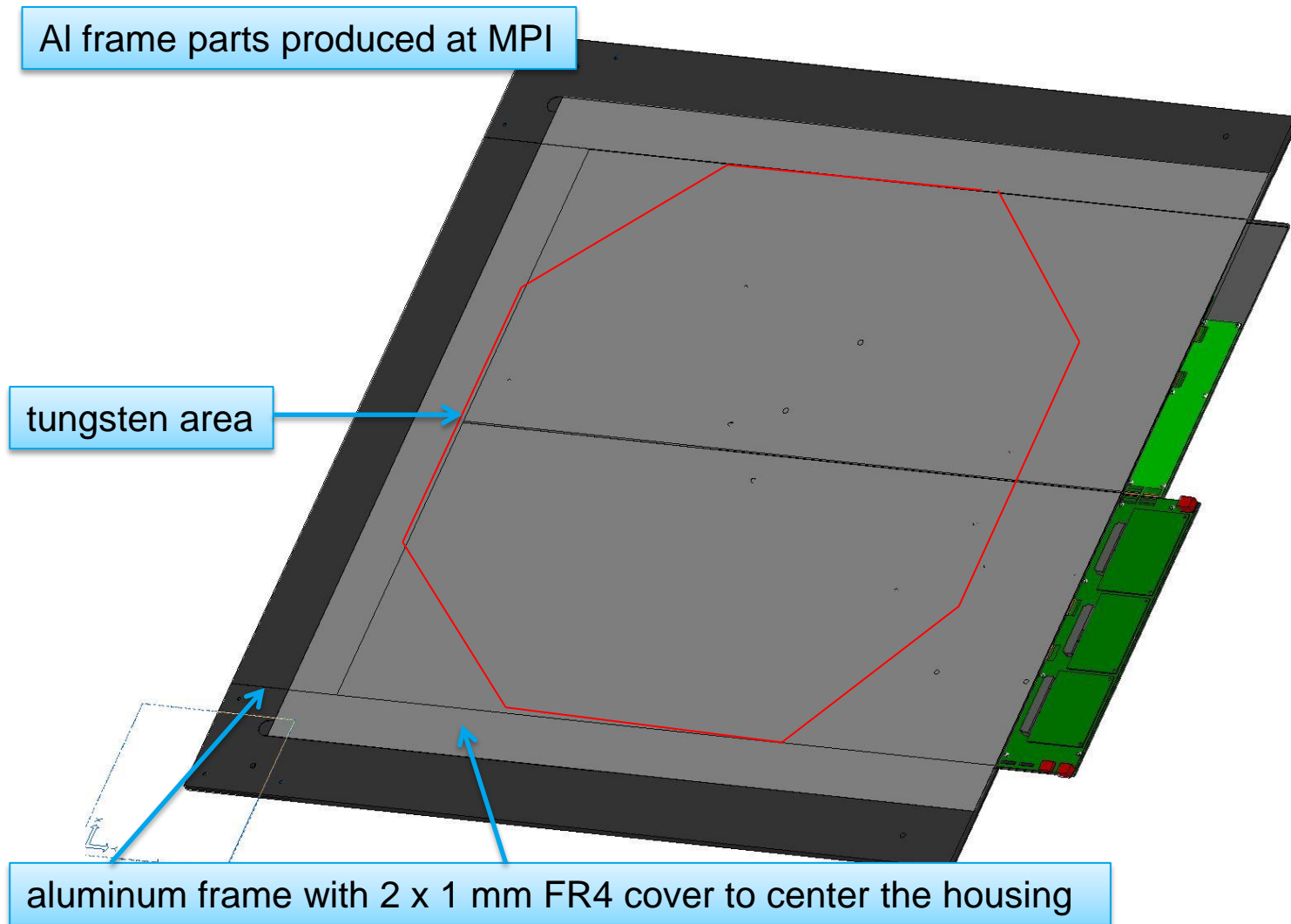

AHCAL Mechanics

Tungsten test beam setup Layer 1 and 2

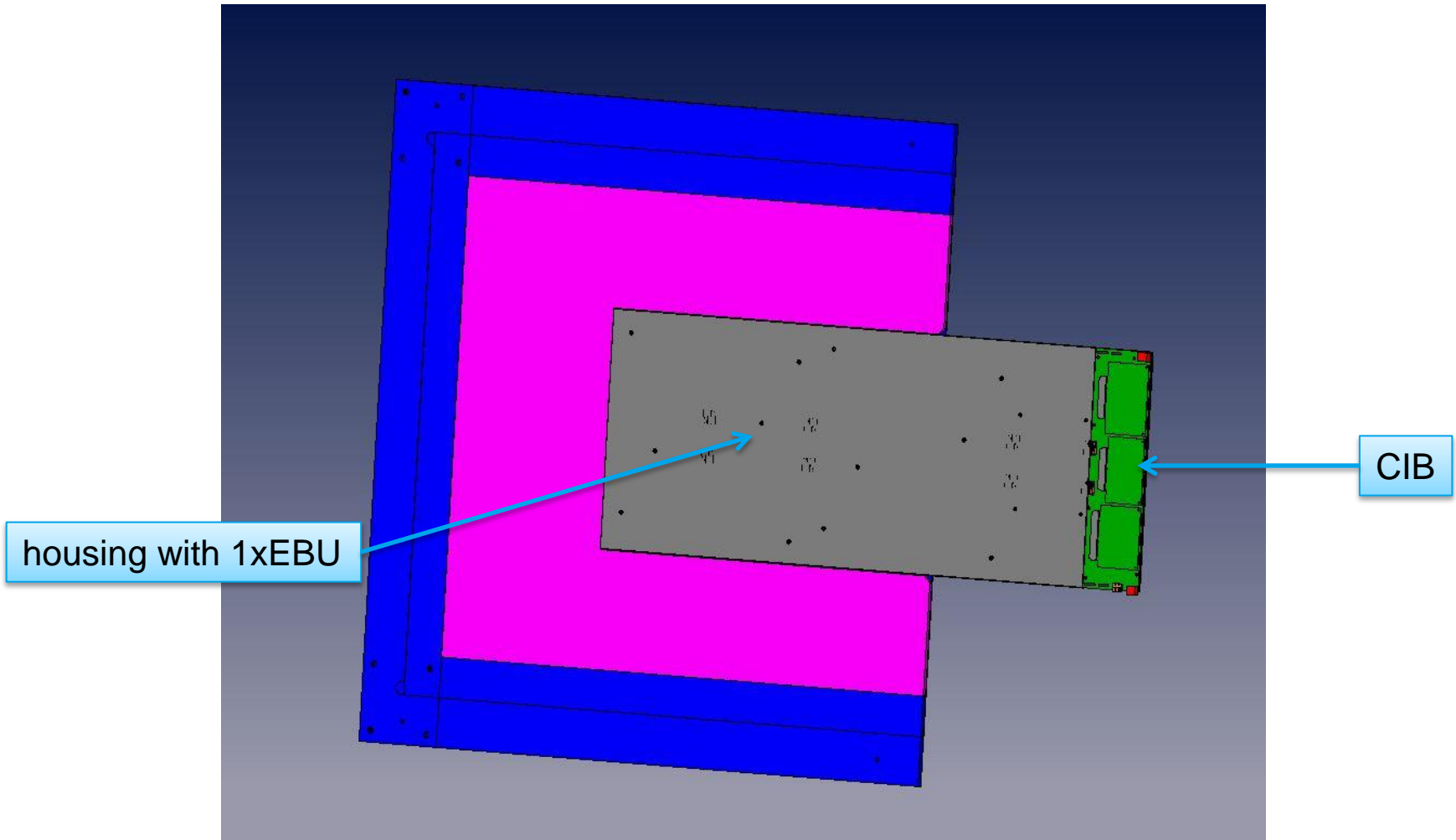

AHCAL Mechanics

Tungsten test beam setup Layer 3 and 10

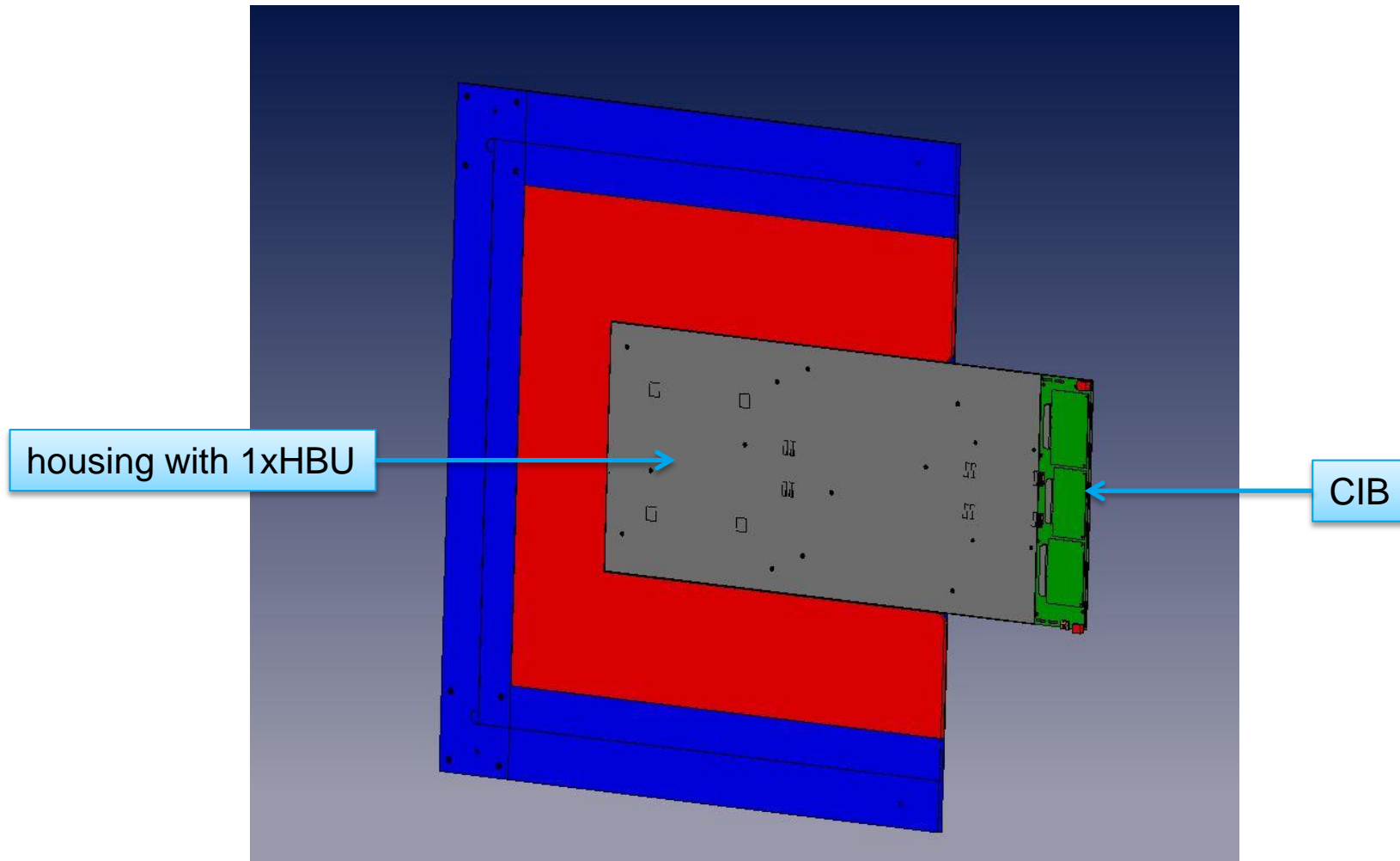

AHCAL Mechanics

Tungsten test beam setup Layer 21 and 31

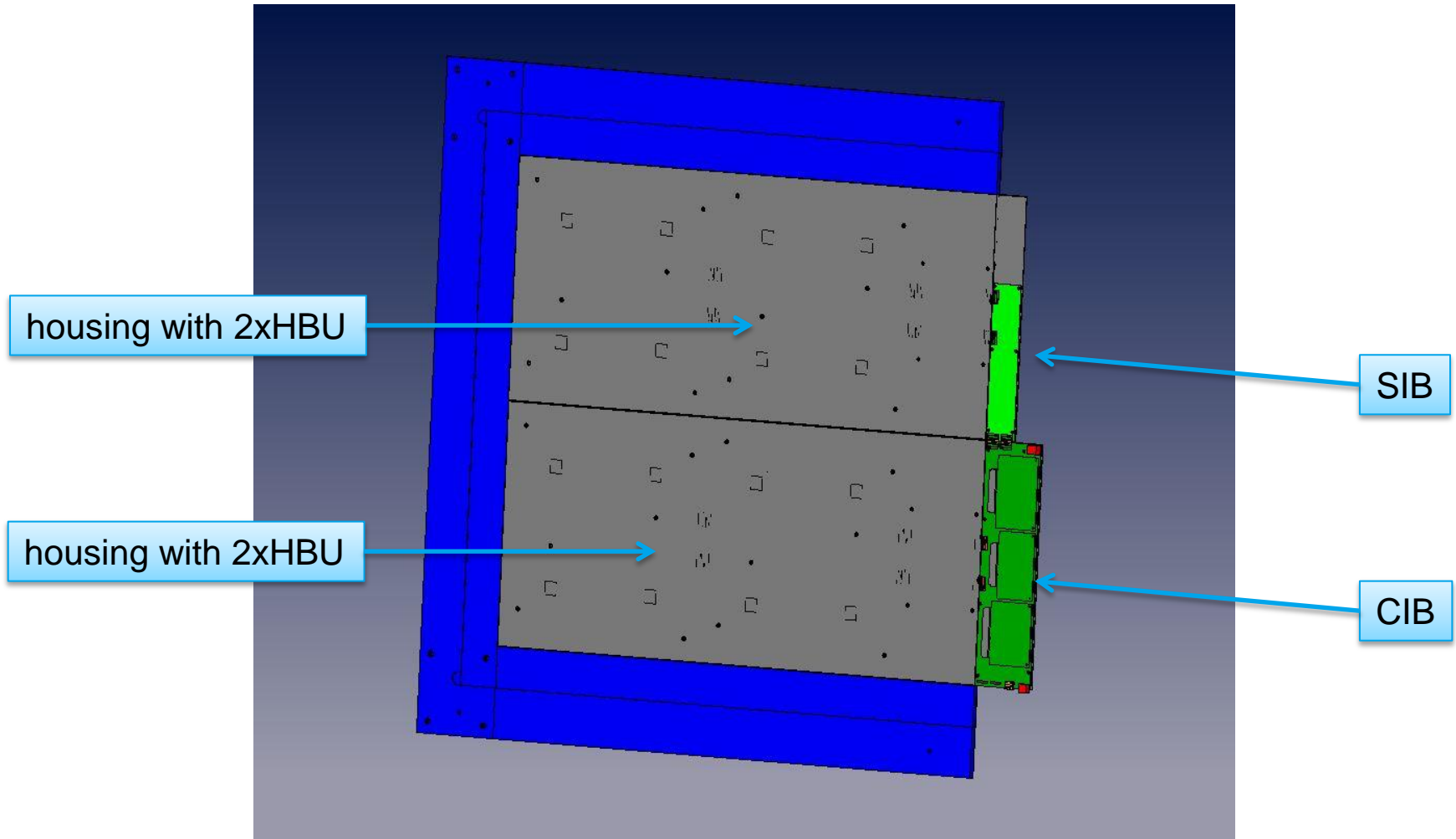

AHCAL Mechanics

Tungsten test beam setup

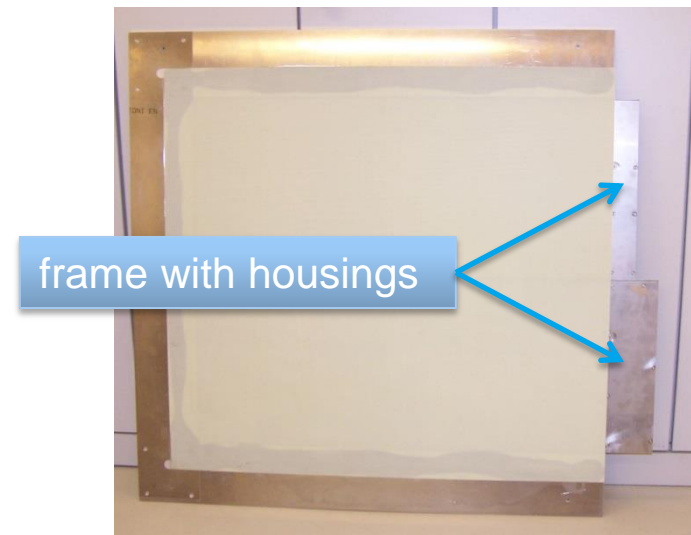
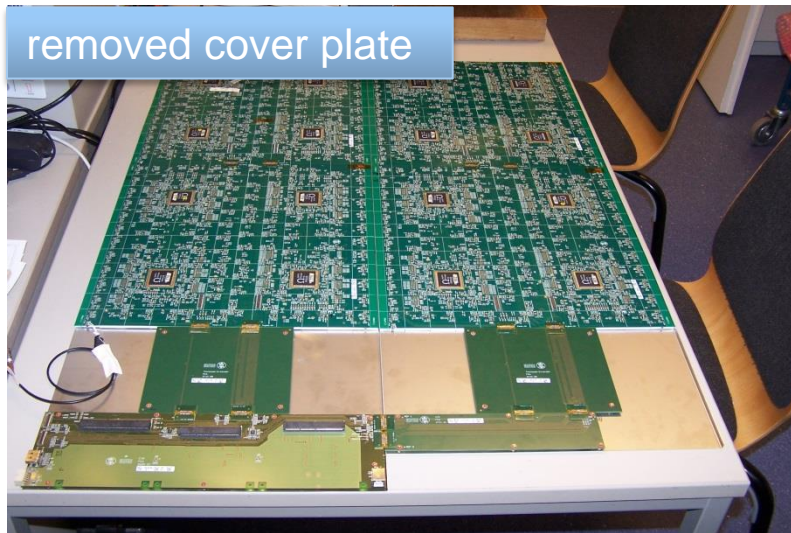
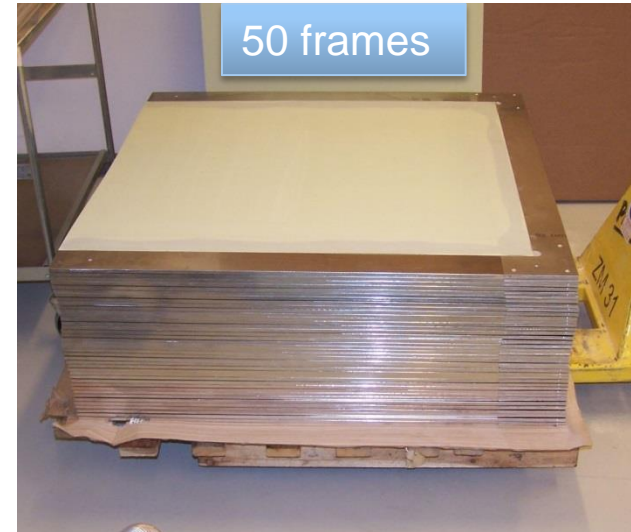

AHCAL Mechanics

Tungsten test beam setup



Modification of the tungsten absorber structure ?

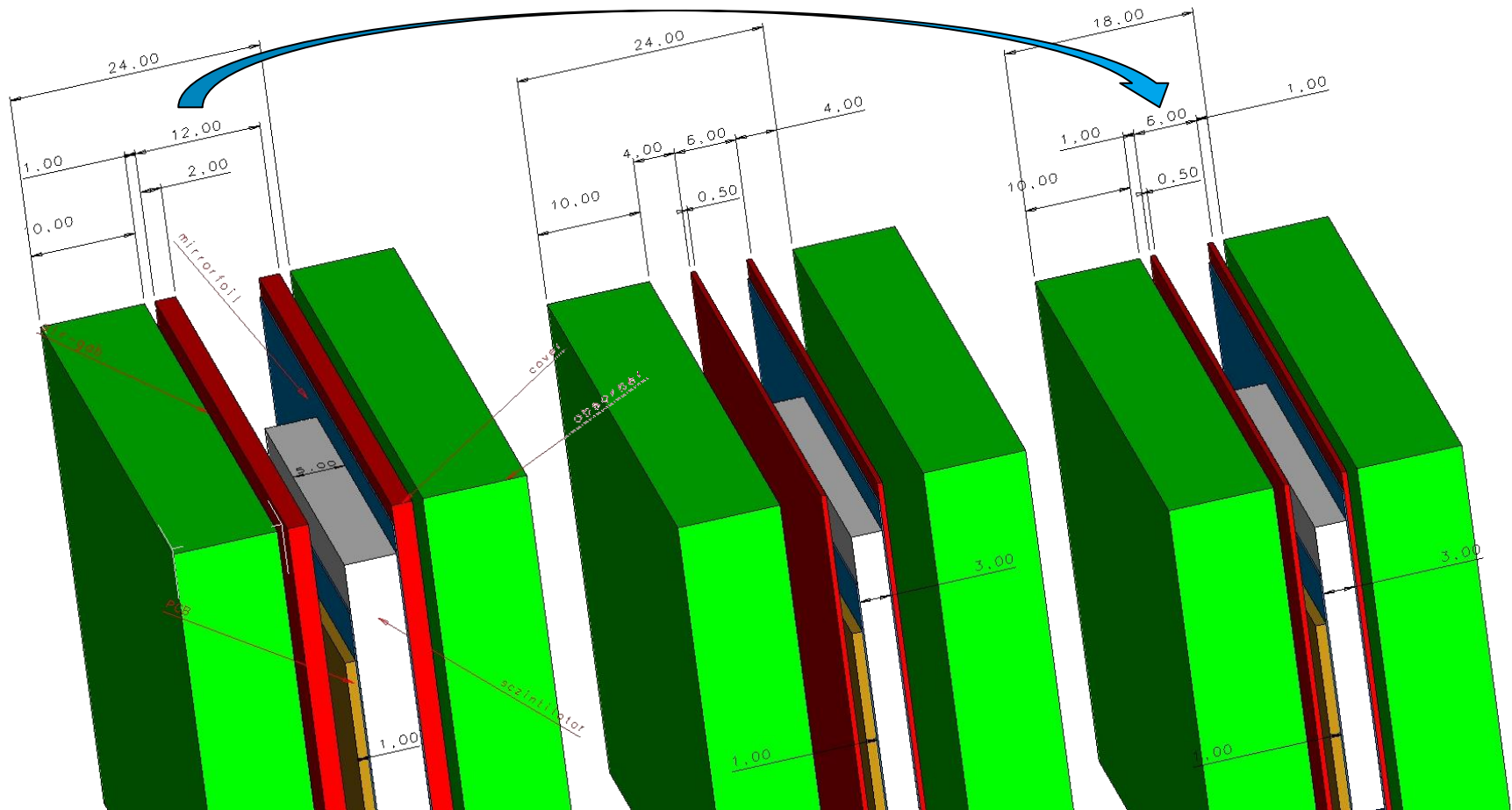

Task list (Summary):

> Test beam setup

- test beam Phase1 or Phase2 ?
- position inside T9 ?
- modify tungsten absorber structure ?
- installation design for self standing absorber structure **done**
- supply, read out and cooling scheme **done**

> Detector layer production

- production of housings **ongoing**
- production of 16 equipped HBU ?
- production of extender cards ?
- production of support frames **done**
- production of inner support plates **ongoing**

Detailed Schedule as to be worked out during this Meeting!



1. Mechanics for test beam setups
2. EUDET test beam setup
3. Tungsten test beam setup
4. **Cabling and cooling**
5. Absorber structure validation (earth quake)



AHCAL Mechanics

Cabling and Cooling setup

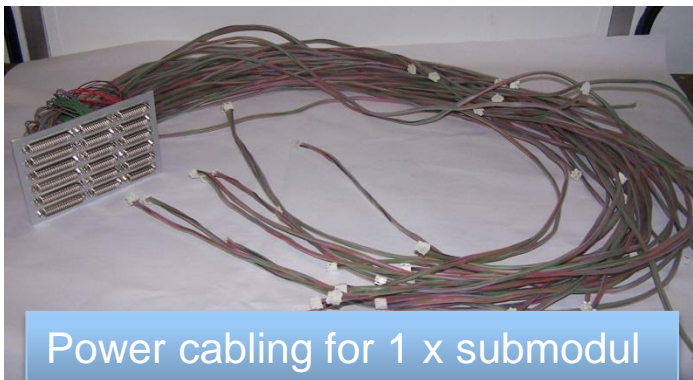
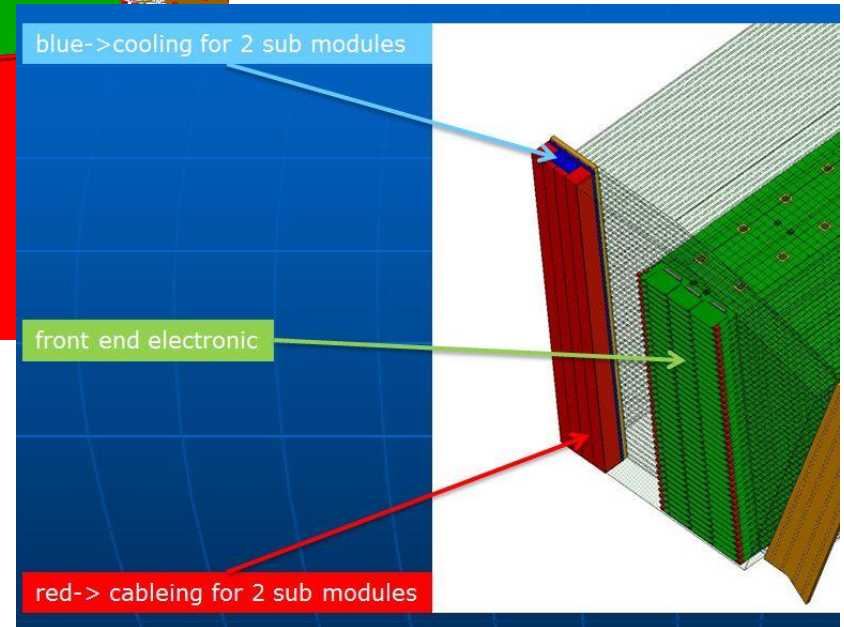
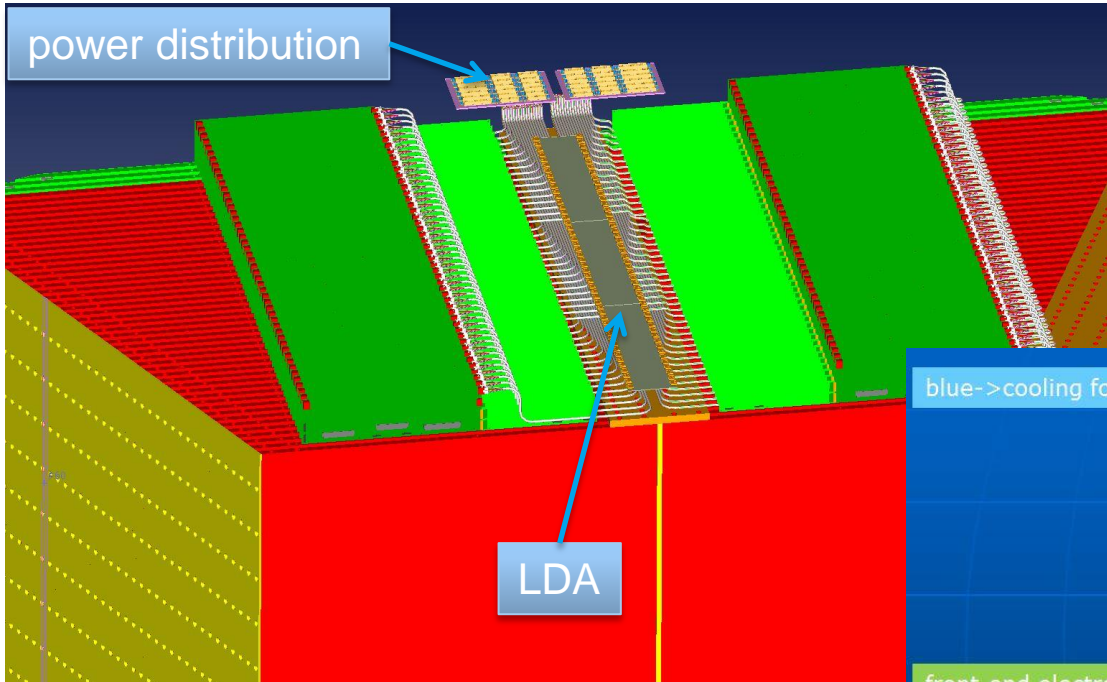

Power cabling for 1 x submodul

1. Mechanics for test beam setups
2. EUDET test beam setup
3. Tungsten test beam setup
4. Cabling and cooling
5. Absorber structure validation (earth quake)



ILD workshop, Cracow, 24-26 September 2013

Summary on seismic issues

1. Earthquake protection will follow the ISO3010; uses analysis with acceleration response spectrum
2. Earthquake model at Kitakami site :
150 gal (100 years) as earthquake representative , where flat period between 0.17 to 0.34sec ($dT_c - T_c$) the amplification factor(f_A) of less than 2.5
3. We would like to analyze ILD earthquake protection.
 - Rigidness of ILD detector
 - Isolation method with respect to the platform and detailed layout needed

2013年 9月 26日 木曜日

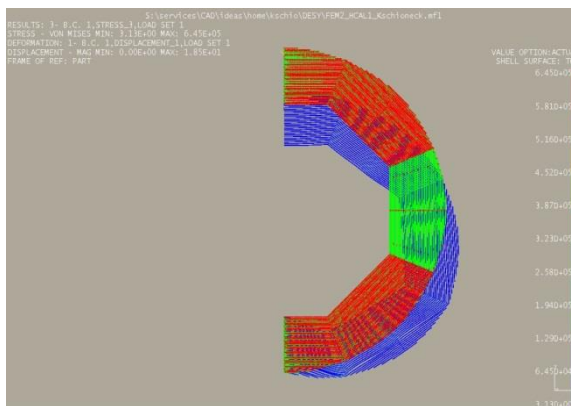

Acceleration Response Spectrum of various earthquakes at the observatories

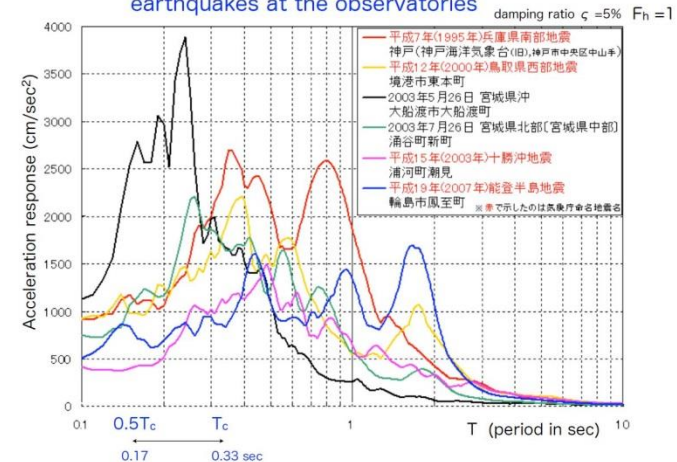

2013年 9月 26日 木曜日

Simulation for AHCAL barrel structure will be done in summer 2014 by DESY-ZM1